



## Workshop Manual

- Golf Variant 2007 ➤
- Golf Variant 2010 ➤
- Jetta 2005 ➤
- Jetta 2011 ➤

### 6-speed dual clutch gearbox 02E

Edition 07.2010





## List of Workshop Manual Repair Groups

### Repair Group

- 00 - Technical data
- 30 - Clutch
- 34 - Controls, housing
- 35 - Gears, shafts
- 39 - Final drive - differential



Technical information should always be available to the foremen and mechanics, because their careful and constant adherence to the instructions is essential to ensure vehicle road-worthiness and safety. In addition, the normal basic safety precautions for working on motor vehicles must, as a matter of course, be observed.

**All rights reserved.**  
No reproduction without prior agreement from publisher.



## Contents

<b>00 - Technical data</b>	<b>1</b>
<b>1 General repair notes</b>	<b>1</b>
1.1 Tools	2
1.2 Gearbox	2
1.3 Overview	3
1.4 O-rings, seals and gaskets	3
1.5 Dual clutch gearbox oil	4
1.6 Nuts and bolts	5
1.7 Electrical components	6
<b>2 Fault finding</b>	<b>7</b>
2.1 General notes on fault finding	7
2.2 Useful information about the „behaviour of the control unit in the event of a gearbox fault“	7
2.3 Special notes on fault finding	8
<b>3 Gearbox identification</b>	<b>10</b>
3.1 Reading gearbox code letters	10
<b>4 Code - engine allocation</b>	<b>13</b>
4.1 Identification code	13
<b>5 Capacity</b>	<b>14</b>
<b>30 - Clutch</b>	<b>15</b>
<b>1 Notes on clutch</b>	<b>15</b>
<b>2 Removing and installing clutch</b>	<b>16</b>
2.1 Removing clutch cover (end cover)	16
2.2 Installing clutch cover (end cover)	18
2.3 Removing clutch	21
2.4 Preparing installation of multi-clutch	22
2.5 Installing and adjusting clutch	24
<b>34 - Controls, housing</b>	<b>31</b>
<b>1 Electrical and electronic components for the dual clutch gearbox and their locations</b>	<b>31</b>
1.1 Removing and installing mechatronic unit for dual clutch gearbox J743 (gearbox installed)	31
1.2 Removing and installing mechatronic unit for dual clutch gearbox J743 (gearbox removed)	40
1.3 Removing and installing gearbox input speed sender G182 and oil temperature sender in multi-plate clutch G509	49
<b>2 Removing and installing gearbox oil cooler</b>	<b>51</b>
2.1 Removing gearbox oil cooler	51
2.2 Installing gearbox oil cooler	52
<b>3 Removing and installing oil pump</b>	<b>54</b>
3.1 Removing oil pump	54
3.2 Installing oil pump	56
<b>4 Renew seal on selector shaft lever</b>	<b>58</b>
<b>5 Selector mechanism</b>	<b>60</b>
5.1 Overview - selector mechanism in vehicles up to 02.2009	60
5.2 Removing and installing selector lever cable - vehicles up to 02.2009	61
5.3 Overview of selector mechanism - vehicles from 03.2009 onwards	68
5.4 Removing and installing selector mechanism with selector lever and selector lever cable - vehicles from 03.2009 onwards	69
5.5 Checking selector lever cable	70
5.6 Adjusting selector lever cable	70



5.7	Emergency release of selector lever	72
5.8	Removing and installing selector lever knob	73
5.9	Checking selector mechanism	74
<b>6</b>	<b>Removing and installing gearbox</b>	<b>76</b>
6.1	Removing gearbox	76
6.2	Installing gearbox	86
6.3	Torque settings	87
<b>7</b>	<b>Transporting gearbox and securing to assembly stand</b>	<b>89</b>
<b>8</b>	<b>Changing oil and filter and adjusting oil level</b>	<b>90</b>
8.1	Changing oil and filter	92
<b>35 - Gears, shafts</b>		<b>95</b>
1	Currently, no repairs can be made to gears and shafts	95
<b>39 - Final drive - differential</b>		<b>96</b>
<b>1</b>	<b>Renewing seals for flange shaft or stub shaft</b>	<b>96</b>
1.1	Renewing oil seal for left flange shaft	96
1.2	Renewing seals for right flange shaft or stub shaft	98

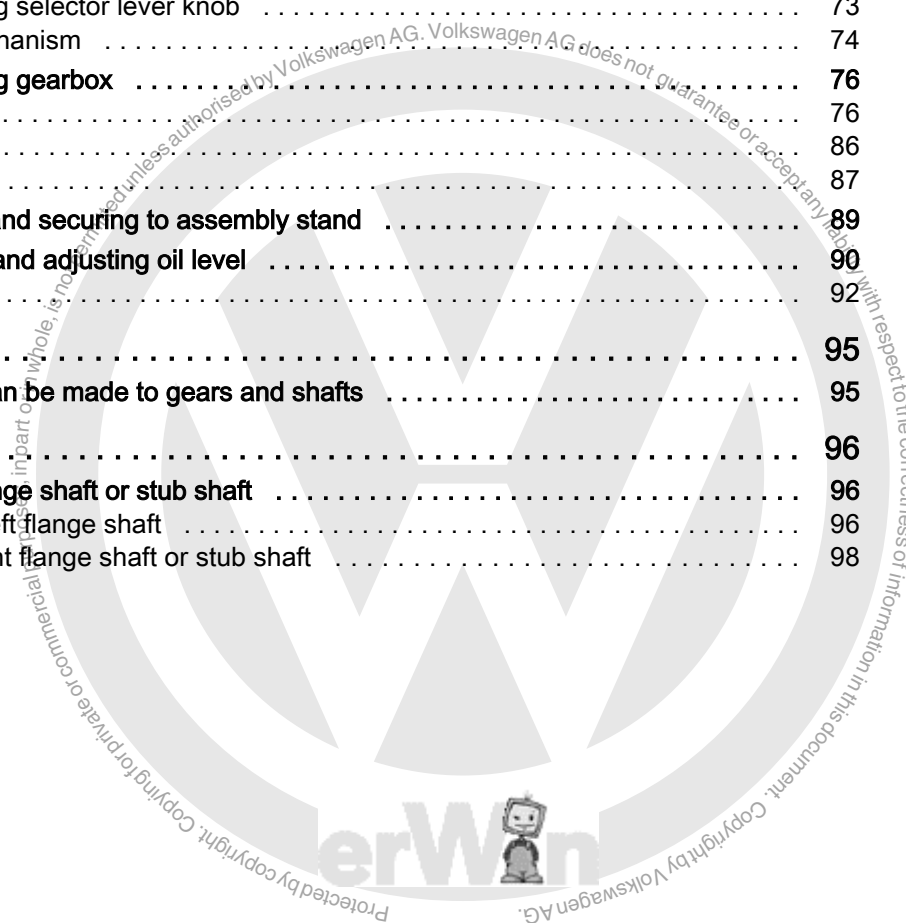



## 00 – Technical data

### 1 General repair notes

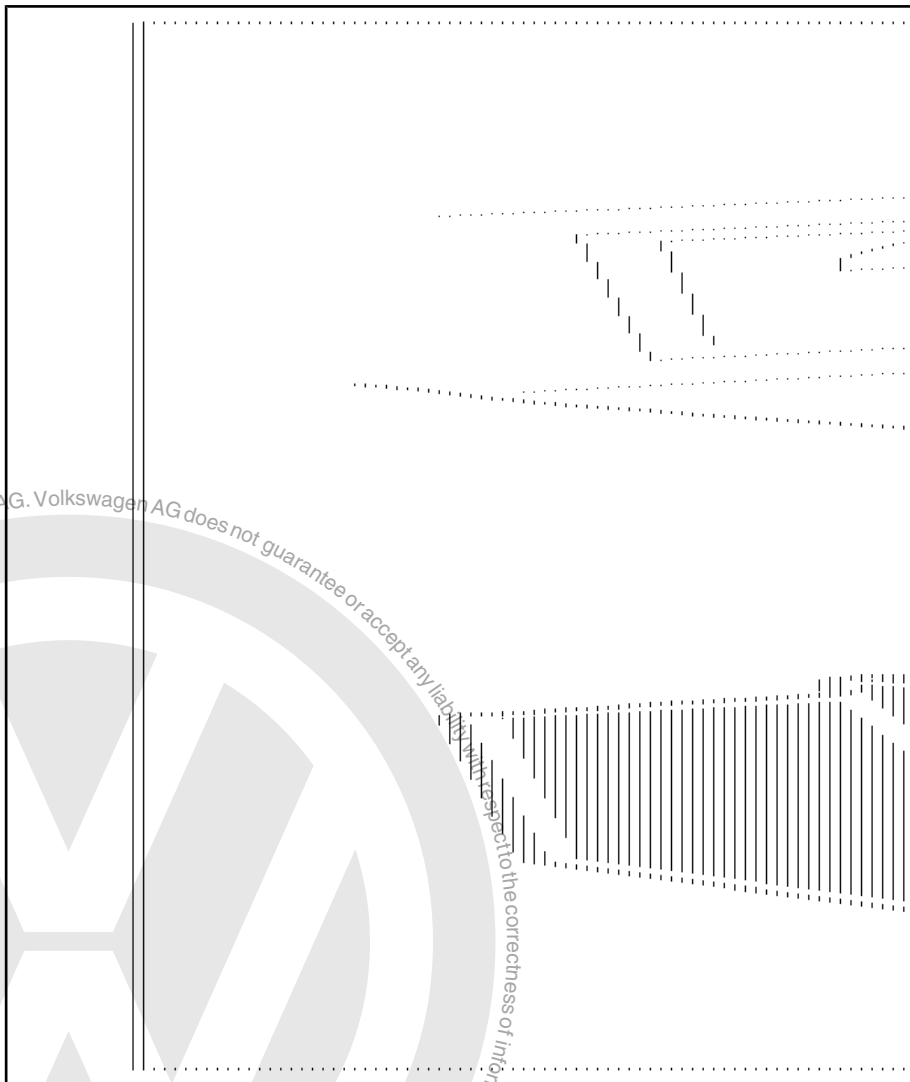

#### **This workshop manual was written for you.**

It should support you and be an aid to you. If you use => ELSA, you can send Volkswagen suggestions and comments from anywhere in the world.

- You can do this by clicking the => Feedback button at the top in the menu bar.

#### **More information on the dual clutch gearbox => DSG@**

You can learn more about how the gearbox works in => Self-study programme No. 308 ; The Dual Clutch Gearbox 02E .

You can gain further information from the => CD ROM => Multi-media training; Dual clutch gearbox .



## 1.1 Tools

A summary of the special tools and workshop equipment used in the workshop manual precedes each repair procedure and can be found in „Special tools/Workshop equipment“ binder.

The catalogue is also available on ⇒ CD-ROM and can be ordered the usual way from Bertelsmann.

Uncertainty often occurs with smaller bolts having low tightening forces. Torque wrench -V.A.G 1783- can be used with these bolts.

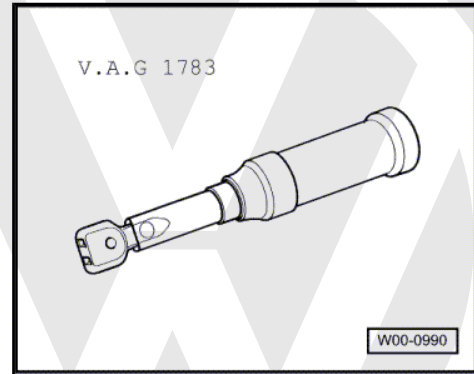

## 1.2 Gearbox

Always make sure that no dirt can enter an »open« gearbox. In particular, dirt entering an »exposed« mechatronic unit for dual clutch gearbox -J743- and/or oil pump can lead to gearbox failure.

- ◆ If gearbox covers have been unbolted or gearbox has no fluid, do not run engine or tow vehicle.
- ◆ First thoroughly clean connecting points and surrounding areas and then loosen bolts.
- ◆ When installing the gearbox, ensure that dowel sleeves between the engine and gearbox are correctly located.
- ◆ Place removed parts on a clean surface. Cover parts to prevent soiling. Use plastic sheeting and paper. Use lint-free cloths only!
- ◆ Install only clean parts; do not remove Genuine parts from packaging until immediately before installing.
- ◆ If repair work cannot be performed immediately, carefully cover or seal components.



## 1.3 Overview

### 1 - Filter ⇒ [page 90](#)

- ⇒ [page 4](#)
- Notes on filter change ⇒ [page 4](#)

### 2 - Inspection plug ⇒ [page 90](#)

- Near pendulum support.

### 3 - Drain plug

- ⇒ [page 4](#)
- Plug was discontinued as of September 2004. The oil can be drained via the inspection plug

### 4 - Gearbox oil cooler ⇒ [page 51](#)

### 5 - Mechatronic unit for dual clutch gearbox -J743- ⇒ [page 31](#)

### 6 - Gearbox input speed sender -G182- and oil temperature sender in multi-plate clutch -G509- ⇒ [page 31](#)

### 7 - Oil pump ⇒ [page 54](#)

### 8 - Cover (end cover) for multi-clutch

### 9 - Multi-clutch ⇒ [page 15](#)

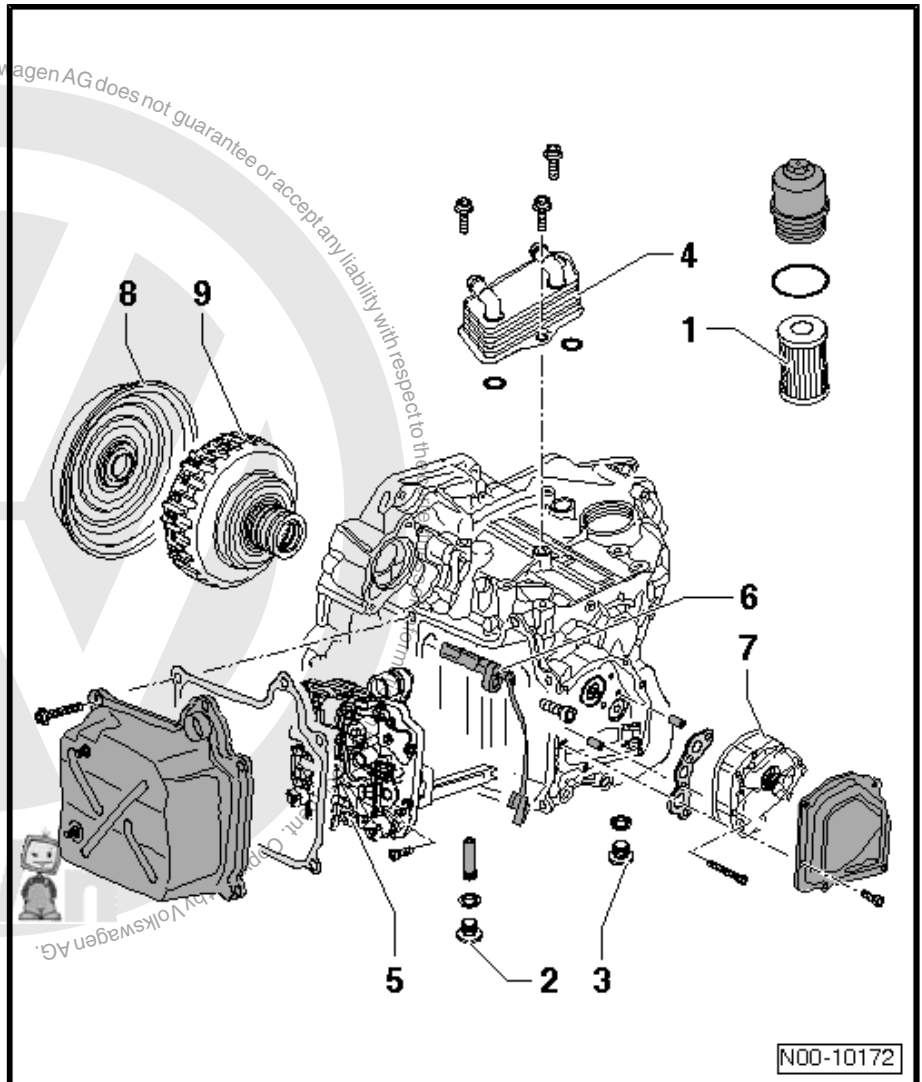

## 1.4 O-rings, seals and gaskets

- ◆ Renew O-rings, seals and gaskets.
- ◆ Before installing a radial oil seal, coat sealing lips and area between these with sealing grease -G 052 128- and outer circumference with dual clutch gearbox oil.
- ◆ Only use dual clutch gearbox oil. Other lubricants will cause problems in function.
- ◆ Open side of radial oil seal faces oil.
- ◆ After installation, change the oil and adjust the oil level at the same time ⇒ [page 90](#) .

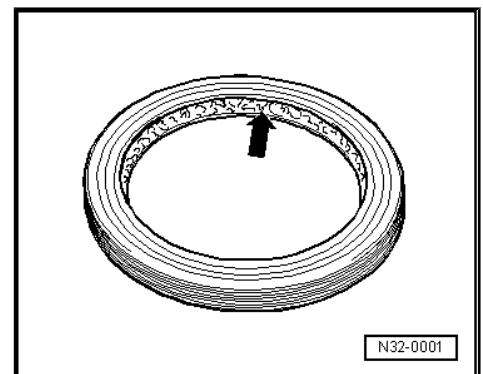



## 1.5 Dual clutch gearbox oil

Shake before opening.

The oil is available as a Genuine part. Therefore the Genuine part number for it can be found in the ⇒ Electronic parts catalogue „ETKA“ .

**The oil quality is of decisive importance for the function of the gearbox.**

Do not mix additives in oil. Do not fill any other oil.

Please also refer to ⇒ [page 4](#) for important information about assessing the oil.

Oil which has been drained out cannot be filled again.



### Caution

*Use caution when handling oil. Dispose of used oil properly. One drop of oil will contaminate 600 litres of water.*

### 1.5.1 Tasks of the oil

The oil does more than just »lubricate« the gearbox.

Consider that the oil just transported minuscule particles of metal from the differential to both filters. This oil ensured that the film of lubricant on the flanks of the teeth does not tear. In the next moment, it provides the pressure necessary for the gear actuators to do their job.

In addition, it seals the spool valves and aids the synchro-rings during gear changes. Oil stores and transports heat and reduces noise. The oil performs many tasks. Dual clutch gearbox oil meets very exacting requirements.

To maintain this ability, the filter on the gearbox should be renewed together with the oil in the maintenance service.

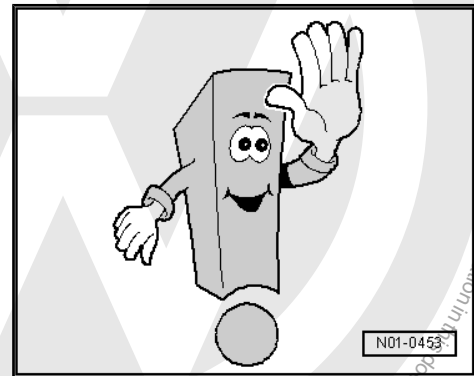

### 1.5.2 Oil filter change - »Yes or no?«

The oil filter does not have to be changed as a matter of course.

**Do not change the filter if:**

- ◆ The gearbox oil cooler or its O-rings have been renewed and no coolant has got into the oil.
- ◆ The oil seal for the selector shaft has been renewed.
- ◆ The oil seal for the flange or stub shaft has been renewed.
- ◆ Leaking covers in the mechatronic unit, the multi-clutch or oil pump have been renewed.
- ◆ The gearbox input speed sender -G182- with oil temperature sender in multi-plate clutch -G509- has been renewed.

**The filter must be changed if:**

- ◆ The 60,000 kilometre service interval has been reached.
- ◆ Coolant has got into the oil.
- ◆ Metal particles have been found in the oil.
- ◆ The clutch is burnt out or has a mechanical defect.



### 1.5.3 Oil and fault finding via oil level check

#### Oil and fault finding via oil level check

You can read about all the things that oil does here [=> page 4](#).  
There is one thing it cannot do: »disappear without a trace«.

Oil can only go missing if it has run out of the gearbox.

#### Gearbox oily

- First, check where the oil has escaped from the gearbox. Repair this leak first. Only then add fresh oil to achieve the »correct« oil level [=> page 90](#).

»Just« topping up the oil doesn't repair any defects. It doesn't help to find the fault, but it gives one an unjustified feeling of security.



N00-10244

### 1.5.4 Oil drain and inspection plug -A-

To gearbox manufacture date „20 September 2004“, gearboxes were constructed with 2 plugs.

The second plug was then discontinued, and oil could be drained and the level checked with only one plug -A-.

A plastic overflow tube (with 8 mm hexagon socket head bolt, torque setting 3 Nm) is located behind the plug. Its length determines the oil level in the gearbox.

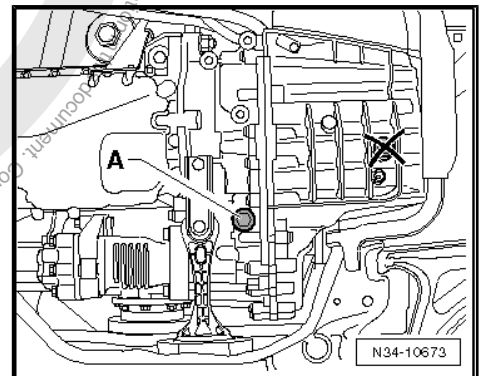

N34-10673

### 1.6 Nuts and bolts

- ◆ Loosen and tighten securing bolts and nuts for covers and housings diagonally.
- ◆ Torque settings are specified for uncoiled bolts and nuts.
- ◆ Threads of bolts secured with locking fluid must be cleaned with a wire brush. Then insert bolts with locking fluid -AMV 185 101 A1-.
- ◆ All threaded holes into which self-locking bolts are to be screwed must be cleaned of residual locking fluid using a thread chaser. Otherwise there is a danger of bolts shearing when subsequently being removed.
- ◆ Always renew self-locking bolts and nuts.

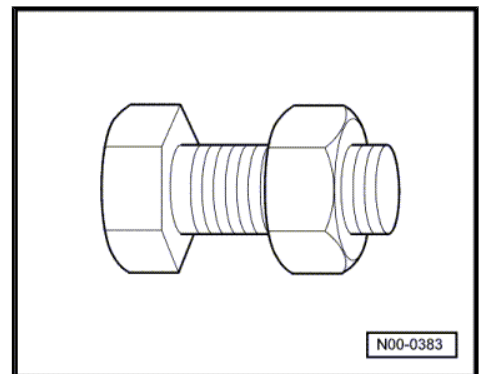

N00-0383



## 1.7 Electrical components

You have probably at some time received an electrical shock when touching a metal object. This is due to the electrostatic charge of the human body. This charge can disturb the function of electrical components of the gearbox and of the selector mechanism.

- Before beginning work on electrical components, touch an earthed object, for example a water pipe or lifting platform. Please do not grip plug contacts directly.

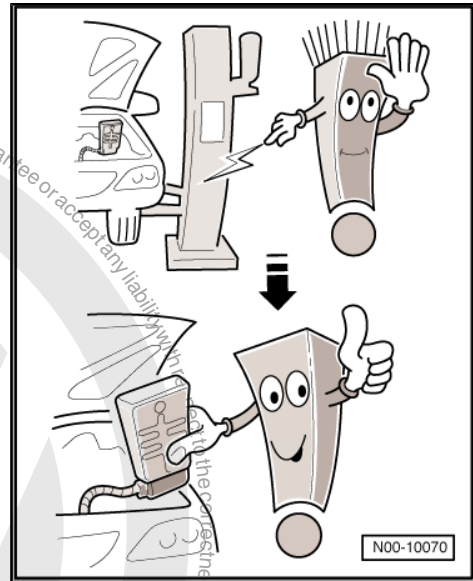



## 2 Fault finding

Before making repairs, determine the cause of the fault as precisely as possible with the aid of „guided fault finding“.

Fault finding is performed with the vehicle diagnostic tester .

### 2.1 General notes on fault finding

#### Planning fault finding

Try to plan the fault search sensibly.

- Be aware »what sort of problem« is on hand and which means of fault finding are available. Finding a fault without a thought-out search would be -magic- and does not lead to success.

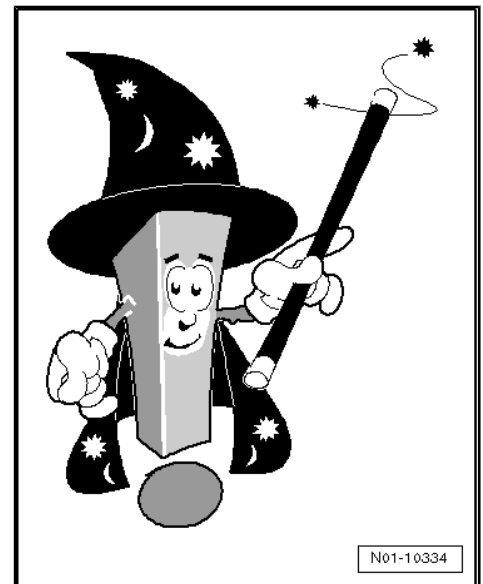

- ◆ It must also be clear that it is not necessary to look for faults which have already been found and are known to others. Therefore, first check ⇒ Technical Solutions to see if a solution to the problem is listed.
- ◆ It is also possible to contact your ⇒ TSC or the importer in your country. Make use of this possibility! This will save time, work and expenses.
- ◆ It can also be helpful to know the faults entered in other control units. Always interrogate all control units. When searching for a fault, keep the bus system in mind. For example, in this case ⇒ [page 9](#) .
- ◆ When calling your importer or the ⇒ TSC, have a diagnosis log on hand.



### 2.2 Useful information about the „behaviour of the control unit in the event of a gear-box fault“

The control unit works with highly developed software. This software is able to execute, monitor and control electronic functions in milliseconds. This control unit »has everything« that a modern gear-box electronics »has to offer«. This must also be considered when looking for faults.

But no electronics can do something for which it was not designed. So it is just not possible to identify electronically for



example, where oil is leaking from the gearbox housing. But it is possible to detect the effects of »insufficient oil«. First a fault in „gear monitoring“ will be detected and finally the control unit will react by opening both clutches (no power transfer).

You should be aware of this when looking for faults and working with Volkswagen testers. It might happen that the source of a fault is not discovered with [Guided fault finding](#).

As well as the more advanced software, a great deal has been done to protect the gearbox in case of a malfunction (safety functions). Consequently, when a fault occurs, if it is necessary, the fault is saved and a substitute program is started.

### Behaviour of the control unit in the event of a fault

If a component in the gearbox malfunctions, the control unit responds with a substitute function. Because the gearbox must be protected as far as possible, there are 4 fault responses:

- 1 - The fault is so minor that travel may be continued with a substitute program and driving safety will be preserved. The driver will not be warned via the selector lever position display -Y5-. The display indicates the selector lever position as usual. It may be possible to notice changes in driving behaviour.
- 2 - Individual selector lever positions blink in the selector lever position display -Y5-. The driver is being warned that it is not possible to select this gear at the moment. For example, driving in reverse: the lever is in „R“ and the vehicle is travelling backwards. If „D“ is selected in this situation, the letter „D“ in selector lever position display -Y5- will begin blinking. In this situation, the control unit prevents 1st gear from being engaged to prevent damage to the gearbox. The gear will not be engaged until the vehicle has stopped moving. If you should want to try this out, be careful.
- 3 - The selector lever position display -Y5- is completely illuminated and is blinking. The selected selector lever position is recognisable or is highlighted. For example: the gearbox oil temperature is too high. Some possible causes may be the towing of a trailer with too great a load or retrofitted components at the front of the vehicle leading to »insufficient air cooling«.
- 4 - The selected selector lever position is not recognisable. The selected range display -Y5- flashes. Changes in driving and gearshift behaviour are clearly apparent. Reversing not possible. A »major fault« has occurred. Part of the gearbox has been switched off and the gearbox must be repaired.

## 2.3 Special notes on fault finding

### 2.3.1 Selector lever position display - no „R“

Simultaneous illumination of all selector lever position display segments indicates gearbox emergency running mode. The vehicle cannot reverse.



### 2.3.2 Touch function does not work - no gear change

Check securing clip on cable support bracket of selector lever cable on top of gearbox. In particular, clip -B- must never be reused.

Due to the loss of its »own tension«, this clip -B- may go lost. The -arrow- points to the Bowden cable adjusting screw.

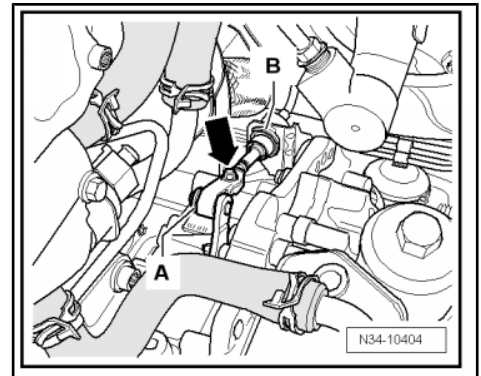

### 2.3.3 »Power transfer« inadequate - possibly insufficient fluid

First click here => [page 4](#) .

Top up fluid only when it has been ascertained that fluid has escaped. Anything else is »expensive fun« which will not help.

### 2.3.4 No faults have been saved

In this case, the solution depends on you. Experience shows that »faults« attributed to the gearbox often are caused by other components or assemblies.

It has occurred in the past that poor shifting behaviour was due to insufficient air intake of the engine. Don't make the same sort of mistakes.

Only after such faults have been excluded can one work meaningfully with the VW tester.

### 2.3.5 Faults have been saved

First consider what the saved faults indicate. The VW testers offer Guided fault finding. Properly used, Guided fault finding will locate the sources of many faults.

### 2.3.6 If there are faults »not caused by the gearbox«

For example, if the fault „ABS signal missing“ is saved in the gearbox memory and additionally another control unit reports „ABS signal missing“, then the gearbox control unit is not likely to be »faulty«.

The entry means only that the gearbox (and possibly other control units) are expecting a signal via the bus, but does not receive it. In this case, it is more likely that the => ABS control unit has a problem. In such a case, under no circumstances should the mechatronic unit for dual clutch gearbox -J743- be removed without further consideration. The fault in this example indicates problems in the => ABS.



### 3 Gearbox identification

Example -arrow-:

GKF - Gearbox code letters

10.05.2 - 10 May 2002

14 - Factory code

14 15 - Time

001 - Serial number

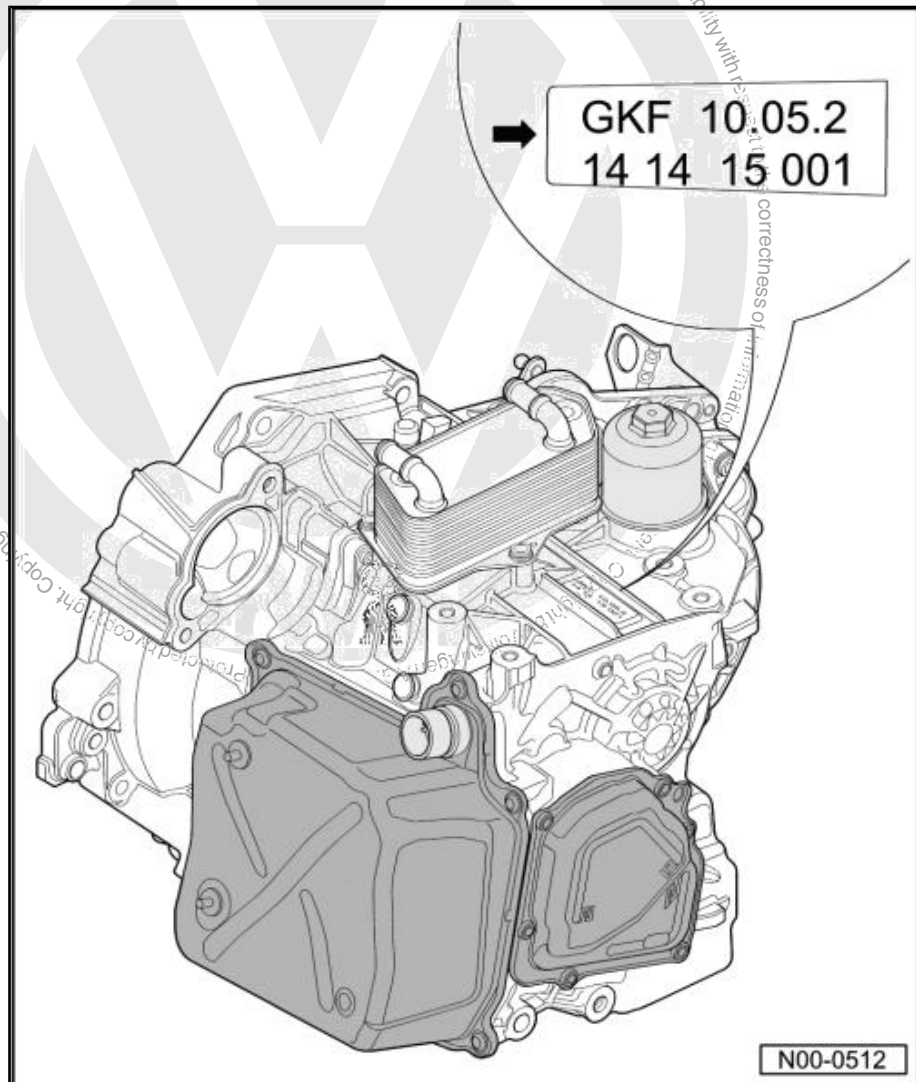

On some gearboxes, gearbox code is also located on the top of the gearbox near the selector lever cable -arrows-.

The gearbox code is also included on the vehicle data stickers.

If there is no vehicle data sticker, if the installed gearbox does not match the one indicated on the sticker or if the installed gearbox cannot be definitively identified: read gearbox code off gearbox.

Reading code directly on gearbox ⇒ [page 10](#) .

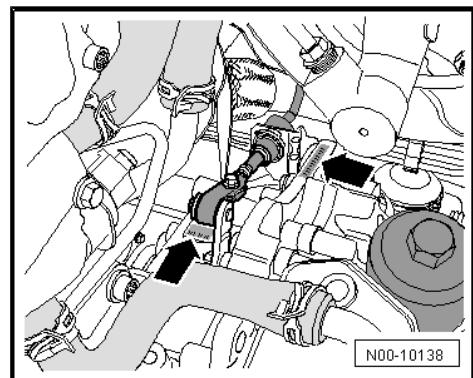

#### 3.1 Reading gearbox code letters

The code appears on every gearbox in at least two places.



Once on top of the gearbox close to the selector lever cable  
-two arrows-.

If it is not legible or is «upside down», the gearbox code may also  
be found under the bracket of the left assembly mounting.

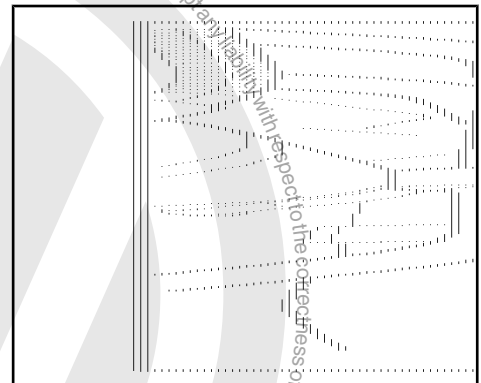
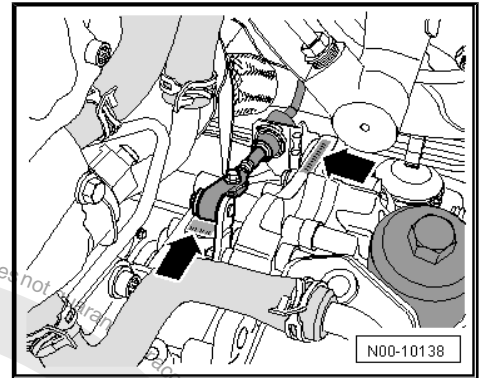

To see the code directly on the gearbox behind the bracket, the  
engine and gearbox must be supported. Bracket -A- for the left-  
hand assembly mounting must be removed. In the process, it is  
important to lower the engine and gearbox only enough so that  
the bracket can be pushed back. If it is lowered further, the  
pendulum support will be damaged. Following assembly, the se-  
lector lever cable must be adjusted => [page 70](#) .

**Perform the following steps:**

- Remove complete air filter housing.
- ◆ Vehicles with petrol engines => Rep. gr. 24 ; Removing and  
installing air filter
- ◆ Vehicles with diesel engines => Rep. gr. 23 ; Removing and  
installing air filter
- Remove battery and battery tray -arrows- => Rep. gr. 27 ;  
Battery; Removing and installing battery .

Set up support bracket -10- 222 A- and support engine with gear-  
box. Do not raise.

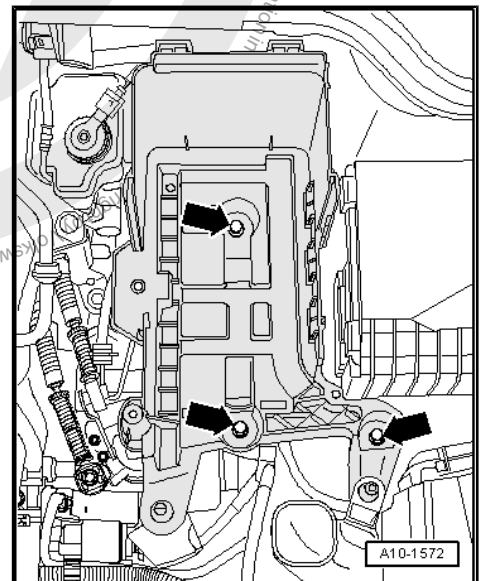

- Remove all bolts -1- and -2- for bracket -A-.

Bolts must be renewed.

- Then lower engine and gearbox slightly using spindles of sup-  
port bracket -10 - 222 A- until bracket can be removed.

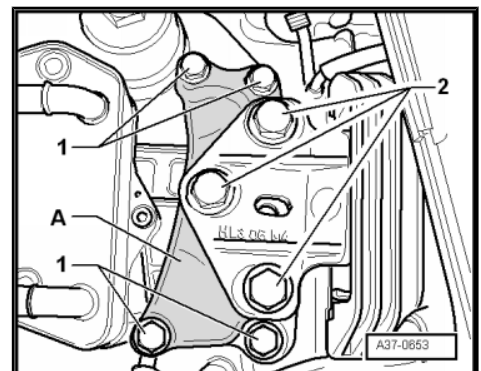



In most cases, 2 turns of the spindle will be sufficient to remove the bracket -arrow-.

After gearbox code has been read, assembly can be performed in the reverse order.

- Nevertheless, observe all the following instructions.
  - Renew all bolts on left assembly mounting.
  - First screw in all bolts by hand.
- 
- For a description of proper installation of bracket -A- on gearbox with bolts -1- and -2-, see ⇒ [page 87](#) .
  - Always adjust selector lever cable after installing bracket ⇒ [page 70](#) .

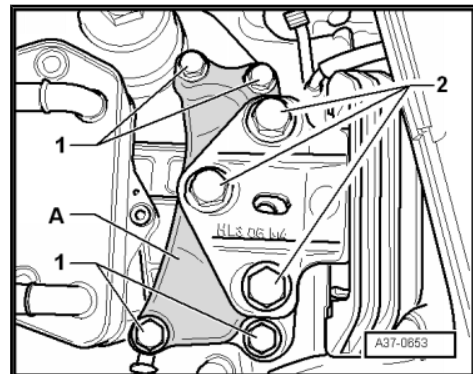
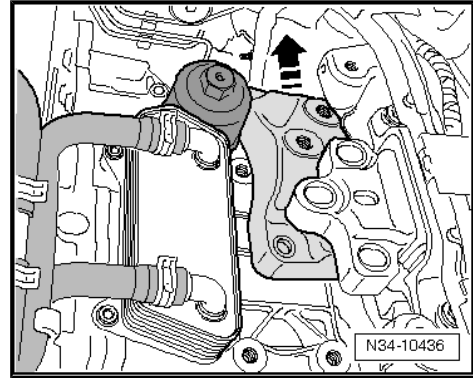



## 4 Code - engine allocation

### 4.1 Identification code

If Genuine parts are required for a repair, always refer to the gearbox code.

Dual clutch gearbox (⇒ DSG®) 02E »front-wheel drive«				
	HVV	GAY, GPV, GPW, GYQ, GYR, HBQ, HLH, HQN, HQH, HQQ, HXU, KPQ	GKF, GPU, GYM, GYN, HBP, HJQ, HLE, HLF, HFQ, HXS, HQF, HQL, HTB, KPS, LQV, LTE, MSV	HBQ, HRW, HUS, HUT, HXW, MSX
	1.4 l - 103 and 125 kW TSI	1.9 l - 77 kW TDI	2.0 l - 100, 103, 125 kW TDI	2.0 l - 147 kW TFSI
Installed in	Golf Variant 2007 ▶ , Golf Variant 2010 ▶ , Jetta 2005 ▶ , Jetta 2011 ▶			





## 5 Capacity

Capacity	Dual clutch gearbox 02E
Initial filling in factory	6.9 ... 7.2 l depending on vehicle and date of gearbox construction
Change quantity in custom- er service	about 5.2 l
Lubricant	Dual clutch gearbox oil

The oil is available as a part. Therefore the part number for it can be found in the ⇒ Electronic parts catalogue „ETKA“ .

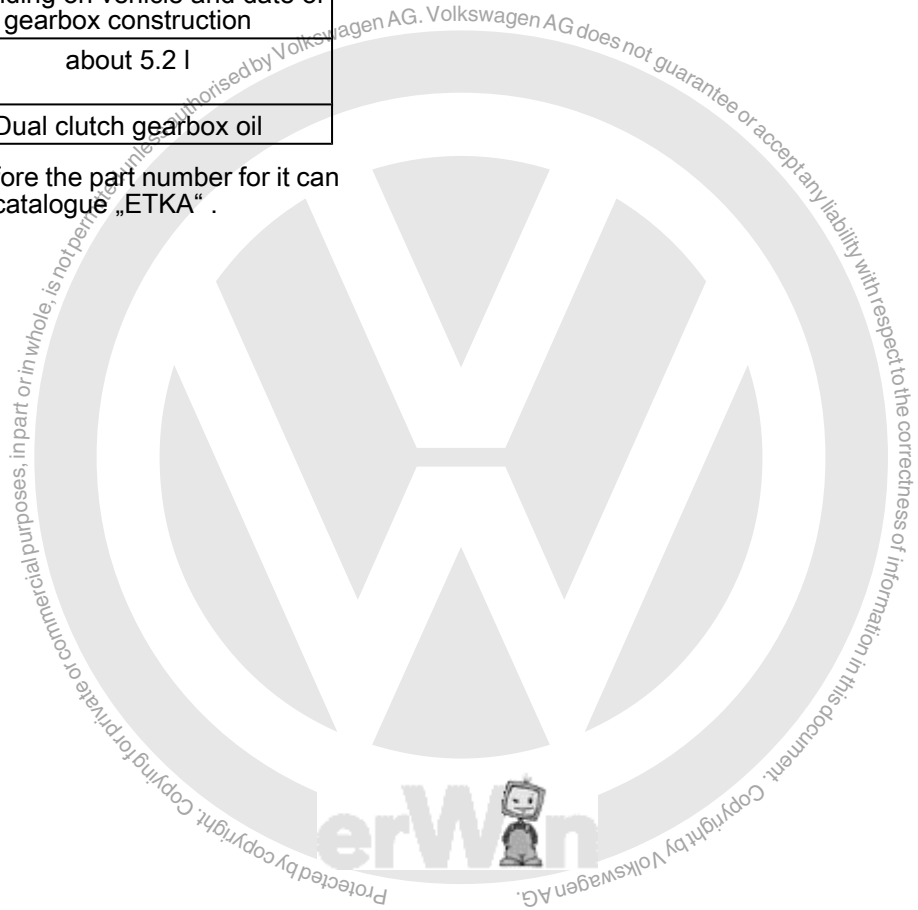



## 30 – Clutch

### 1 Notes on clutch

When carefully considered, the term »clutch« is not exactly correct. Clutches of ⇒ DSG@s always contain at least 2 »clutches«, so the term „multi-clutch“ is more appropriate. In this case, the clutch has 2 sets of plates - making it a ⇒ wet clutch. The outer, larger set of plates is called „C 1“ (clutch 1). The „C 1“ selects reverse gear and gears »1«, »3« and »5«. The smaller inner „C 2“ (clutch 2) selects gears »2«, »4« and »6«.

The assembly of the multi-clutch requires special care because all components have been balanced together during manufacture. If parts are rotated relative to each other during assembly, imbalances develop which are detrimental to ease of shifting and service life.

Therefore, genuine clutches are supplied with a built-in retaining ring.

To avoid the risk of parts rotating relative to each other, the method of assembling and installing the clutch in the gearbox housing is shown here. Therefore, you should carefully refer to this description ⇒ [page 16](#).

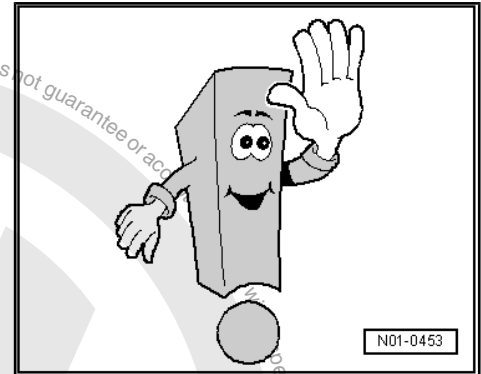

Protected by copyright. Copying for private or commercial purposes is prohibited. Volkswagen AG does not guarantee or accept any liability for the correctness of information in this document. Copyright by Volkswagen AG.



## 2 Removing and installing clutch

It is currently possible to see a film demonstrating how the clutch is removed. At the time of publication, the video was available only in German. The path to the film is ⇒ Volkswagen ServiceNet; VW/Audi TV; Volkswagen iTV; iTV API Online; Motor/Getriebe; Alle Modelle - Hinweise zum Direkt-Schalt-Getriebe DSG . If and when it appears in English, the last two levels will be approximately "Engine and Gearbox" and "All models - notes on dual clutch gearbox DSG".

The cover over the clutch must be removed before the clutch can be removed ⇒ [page 16](#) .

### 2.1 Removing clutch cover (end cover)

Perform the following steps:

The cover seals the gearbox. The cover is held in place by a retaining ring. After the retaining ring has been removed, the cover can be levered out of its seat. Cover and retaining ring must always be renewed. Never install a new cover with a hammer and never oil the centre seal or touch it with a hand! However, if this should happen, the cover is certain to leak!

The gearbox must be removed for work on cover.

- Remove gearbox ⇒ [page 76](#) .
- Secure gearbox to assembly stand ⇒ [page 89](#) .

- Drain oil.

To gearbox manufacture date „20 September 2004“, gearboxes were constructed with 2 plugs.

The second plug was then discontinued, and oil could be drained and the level checked with only one plug -A-.

A plastic overflow tube (with 8 mm hexagon socket head bolt, torque setting 3 Nm) is located in this hole. Its length determines the oil level in the gearbox.

- Remove this oil pipe.
- Drain oil.
- Screw in overflow pipe with 3 Nm torque.
- Install drain plug -A- with new seal.

**Torque setting: 45 Nm**

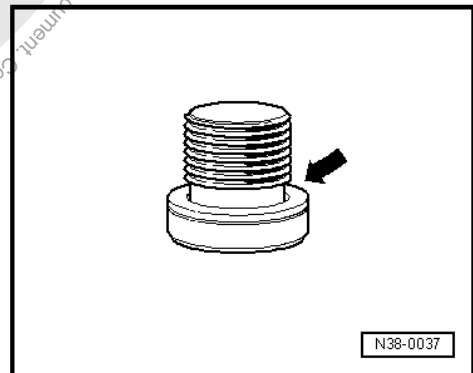
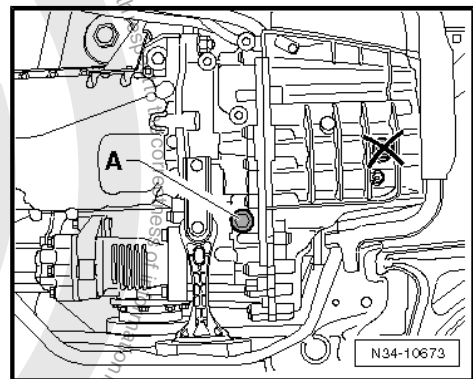
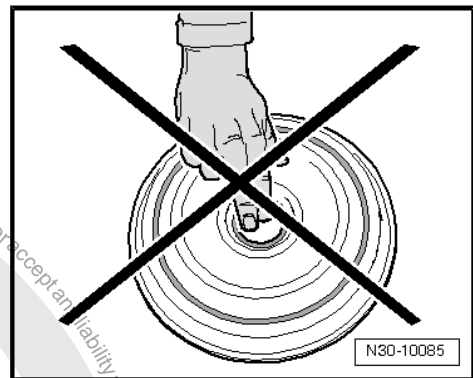



- Remove the filter if necessary.

Often, doubts arise as to whether the filter must be renewed or not.

The notes on the oil filter change ⇒ [page 4](#) can help you in reaching this decision.

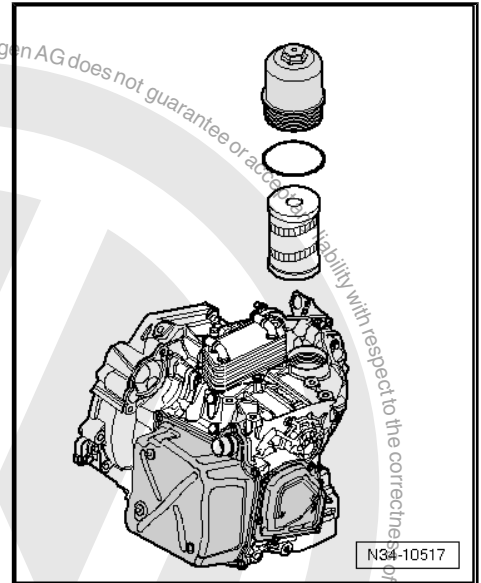

- Insert new filter with shoulder downwards and tighten cover to 20 Nm.

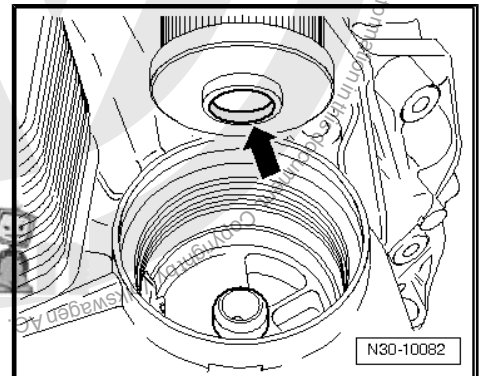

- Following repair work, it is not necessary to change filter again when filling oil.

Remove cover.

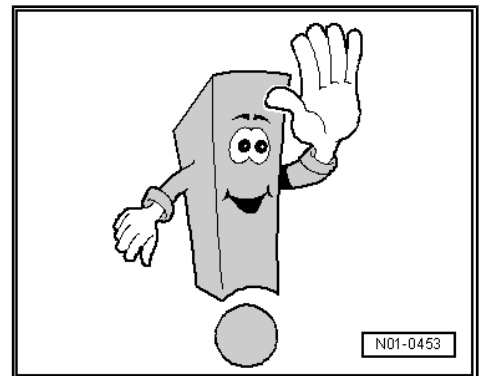

- Remove retaining ring from cover.  
Cover can be levered out with a screwdriver.  
Install only a »new« cover ⇒ [page 18](#) .

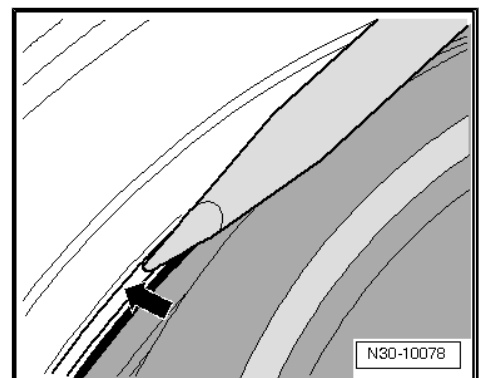



## 2.2 Installing clutch cover (end cover)

There are 2 types of cover.

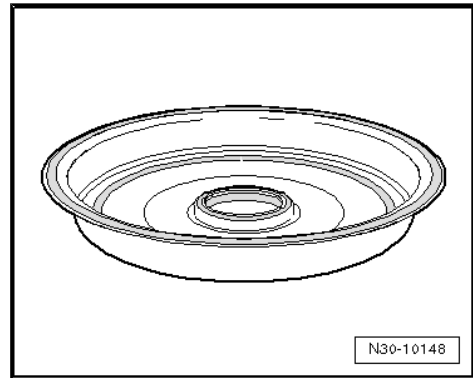

- ◆ Covers supplied without a bush ⇒ [page 18](#) .
- ◆ Covers supplied with a white bush ⇒ [page 20](#) .

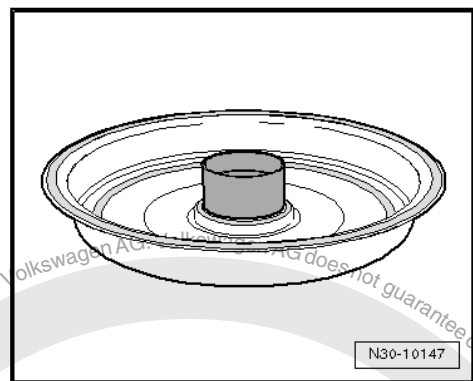

### 2.2.1 Installing covers supplied without bush

Perform the following steps:

Cover and retaining ring must always be renewed. Never install a new cover with a hammer and never oil the centre seal or touch it with a hand!



#### Caution

*Do not grasp new cover in centre hole. The hole of the cover must not be touched, oiled or brought into contact with other materials. Leaks will result.*

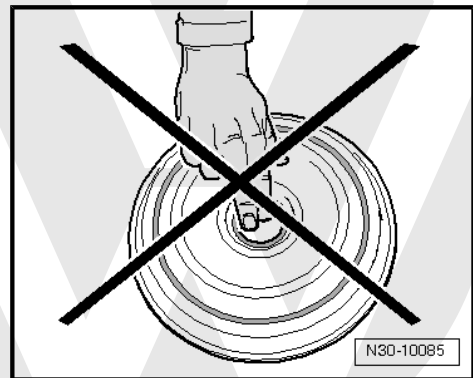

- Only handle cover as shown in the picture!

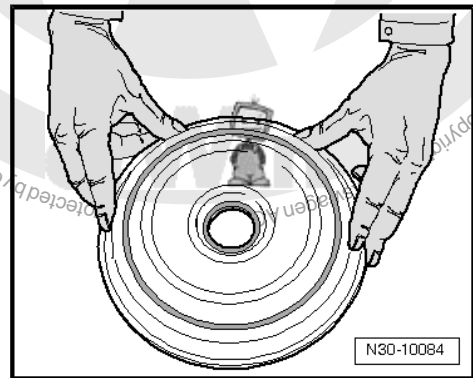

Special tools and workshop equipment required



◆ Assembly sleeve -T10302-

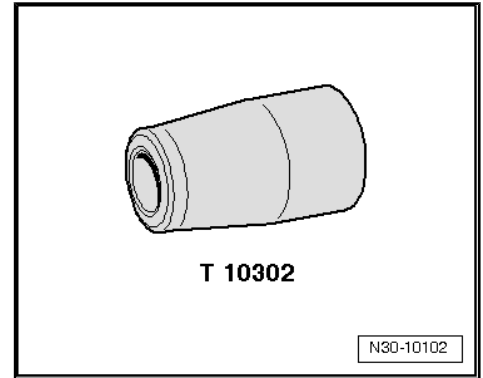

Caution

*Clean assembly sleeve before using. Do not use a scratched sleeve.*

New cover must be free of oil and dry around centre seal!

- If necessary, clean end of clutch shaft.

There must be no stickers on the inside of the cover.

- If any stickers are present, remove them carefully!

Moisten only the outer edge of the seal with DSG oil.

- Set sleeve on a flat surface.

The centre seal of the new cover must now be »preformed«:

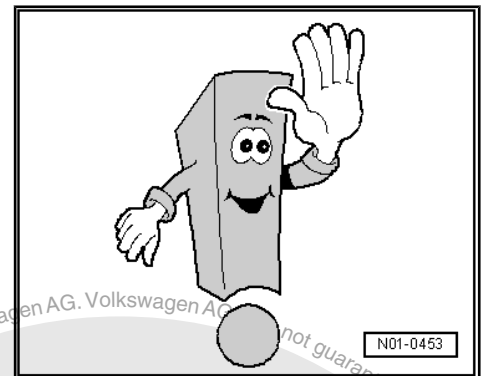

- Guide cover horizontally and evenly over entire sleeve. This will bring the sealing lip into installation position.
- Now remove sleeve upwards out of cover and set sleeve on end of clutch shaft

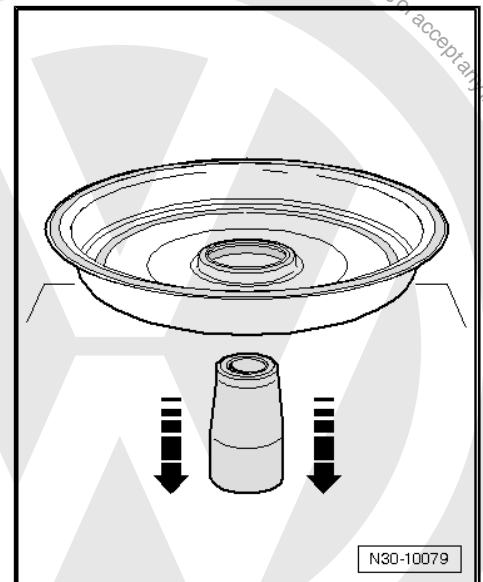



- Guide cover horizontally over sleeve and press evenly onto its seat.



**Caution**

*Work carefully. Any sort of blow to the cover is certain to cause leaks.*

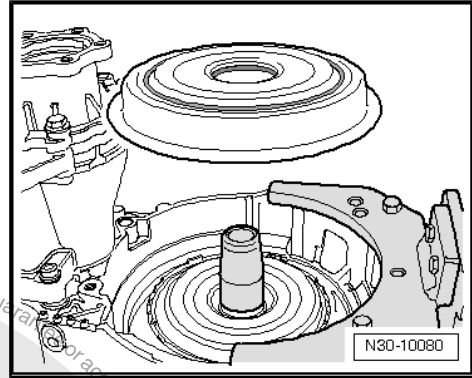

It is possible to lever cover carefully into its seat with a screwdriver -arrow- until »new« retaining ring can be installed.

- Install new retaining ring.

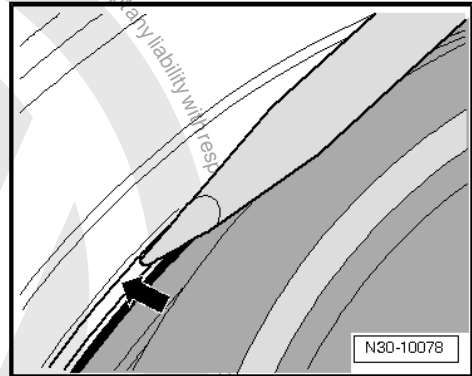

## 2.2.2 Installing covers supplied with bush

Perform the following steps:

Cover and retaining ring must always be renewed. Never install a new cover with a hammer and never oil the centre seal or touch it with a hand!



**Caution**

*Do not grasp new cover in centre hole. The hole of the cover must not be touched, oiled or brought into contact with other materials. Leaks will result.*

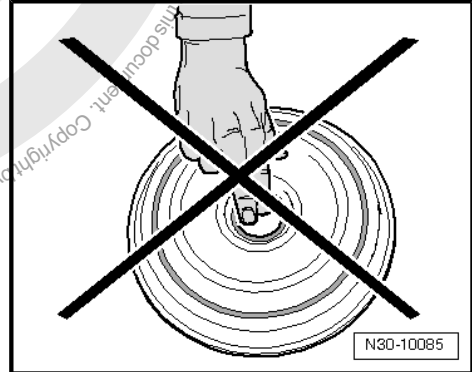

Do not remove bush!

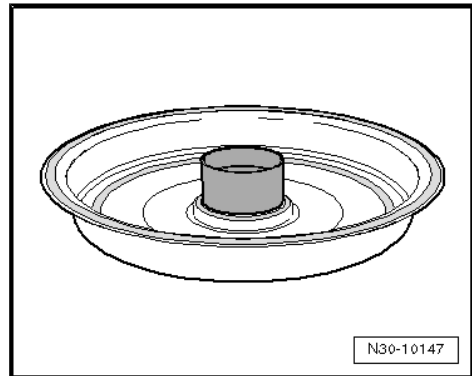



New cover must be free of oil and dry around centre seal!

- If necessary, clean end of clutch shaft.

There must be no stickers on the inside of the cover.

- If any stickers are present, remove them carefully!

Moisten only the outer edge of the seal with DSG oil.

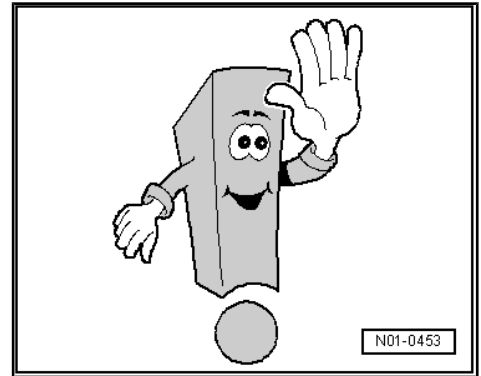

- Insert cover with bush.



#### Caution

**Work carefully. Any sort of blow to the cover is certain to cause leaks.**

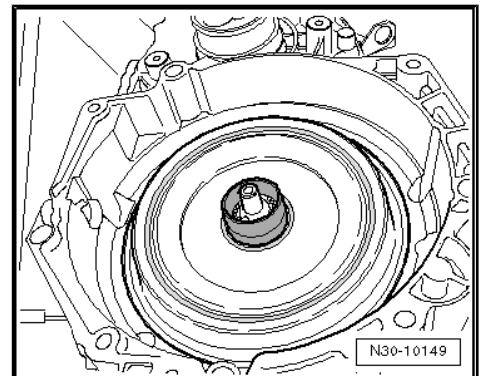

It is possible to lever cover carefully into its seat with a screwdriver -arrow- until »new« retaining ring can be installed.

- Install new retaining ring.

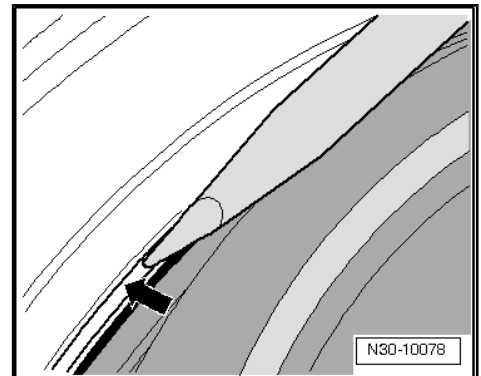

- Do not remove bush until retaining ring is installed.

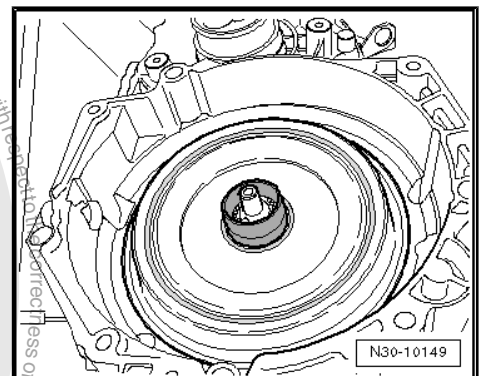

## 2.3 Removing clutch

Perform the following steps:

To remove or install clutch, gearbox must be securely attached to an assembly stand in vertical position.

- Remove clutch cover (end cover) => [page 16](#) .



- Remove retaining ring from clutch cover.
- Remove cover from clutch.

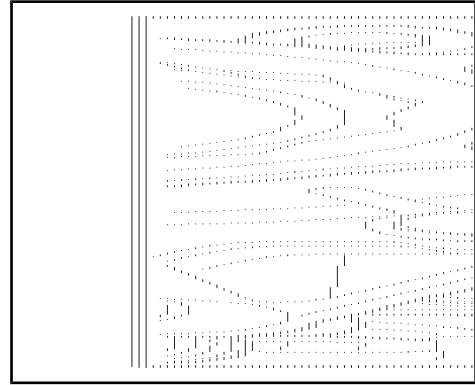

- Remove retaining ring -arrow-.

Note: this retaining ring must be measured again during installation and renewed.



#### Caution

*Carefully remove clutch. Ensure that end cover or other parts of clutch do not fall out. Therefore, do not turn over clutch under any circumstances!*

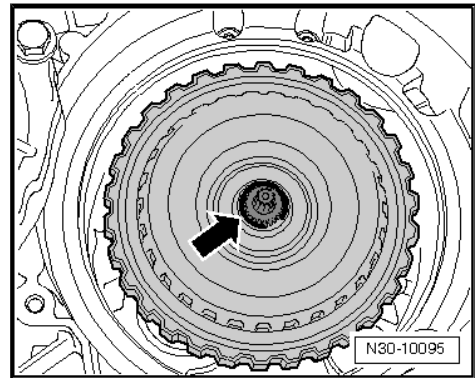

But if this should happen => [page 29](#) .

- Remove clutch.

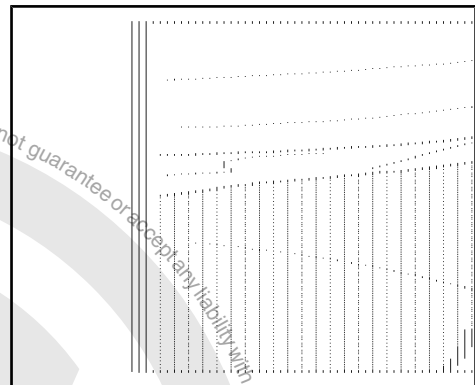

- Remove pump shaft -A-.
- Pump shaft is not inserted until after new clutch is installed. Set shaft aside until then.

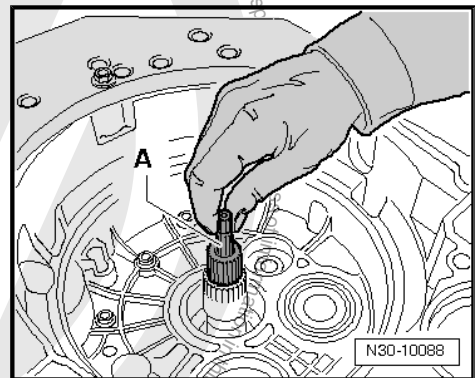

## 2.4 Preparing installation of multi-clutch

### Multi-clutch as replacement part



**1 - Multi-clutch**

- The cover of a new clutch is secured with a retaining ring.

**2 - Retaining rings**

- Qty. 10
- Rings have different »thicknesses«. They are sized in 0.1 mm increments.
- Refer to instructions in [⇒ page 24](#).

**3 - Cover (end cover)**

- Ensure that inner sealing lip is not damaged [⇒ page 18](#). Manufacturer inserts a bush to protect sealing lip. Please leave this bush in cover.

**4 - Retaining ring**

- For cover.

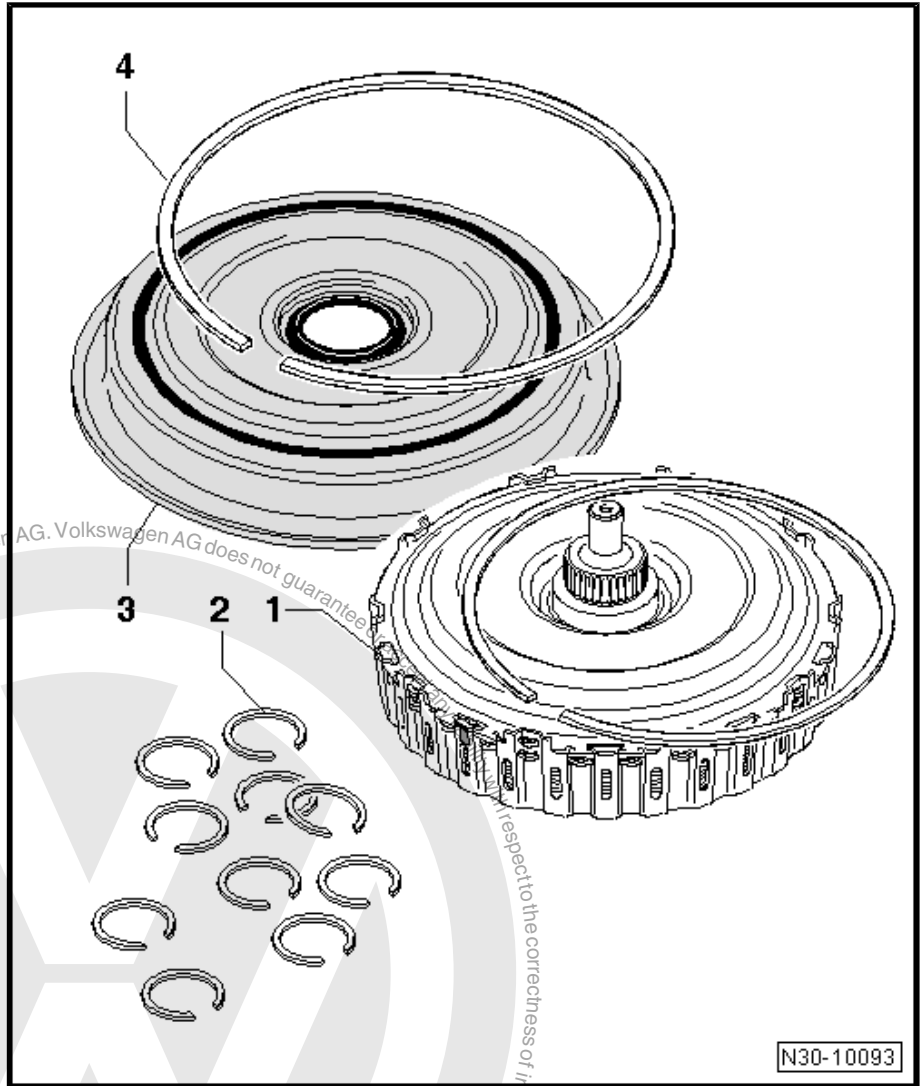

- When removing clutch from packing, press on clutch cover.

This is to prevent the clutch cover and the plate carriers beneath it from sliding out of the inner plates.

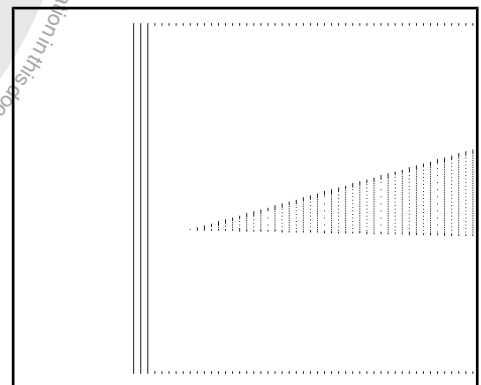



- Make sure that the 4 -piston rings- are correctly located.  
Ring gaps should not be »over each other«.
- Turn rings once. They must move freely and must not bind.

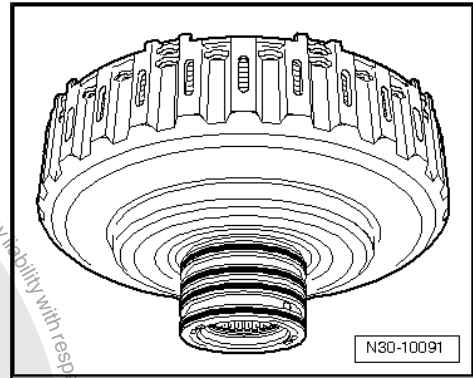

### Important! Position of clutch cover

Look to see whether there is a marking on clutch -arrow-.

If there is no mark, make a coloured mark. Later the »lug« of the cover must be placed at the marked spot.

### Set down clutch so that it cannot tip over.

The clutch is now ready for installation ⇒ [page 24](#) .

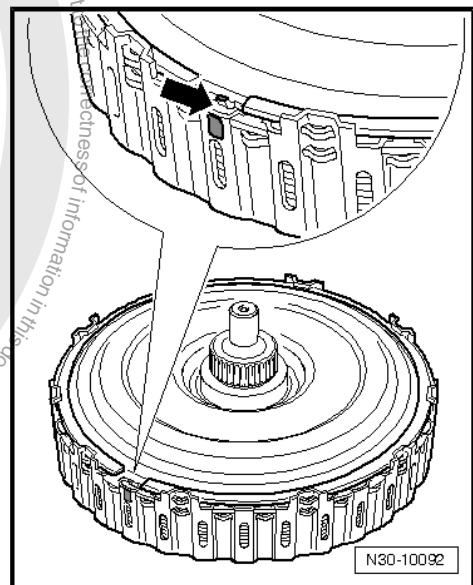

## 2.5 Installing and adjusting clutch



### Caution

*Avoid removing or lifting plate carriers. Not even a little bit! The plates could turn.*

### Perform the following steps:

- Gearbox must be turned »vertical in assembly bracket«. Only this way is it possible later to adjust axial play of the clutch without error.
- It is essential that the gearbox be securely clamped in support clamp -VW 313- or engine and gearbox support -VAS 6095- ⇒ [page 89](#) . It must not be turned.
- Inside the clutch, the large plate carrier goes through all plates. It must not slip out of the lowest plates.
- The pump shaft of the oil pump is removed.
- Do not install corrugated retaining rings.

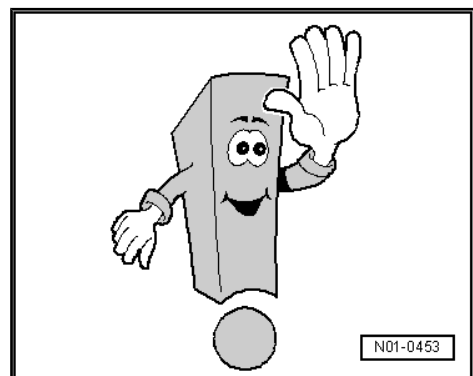

### Special tools and workshop equipment required



◆ Retaining pin -T10303-

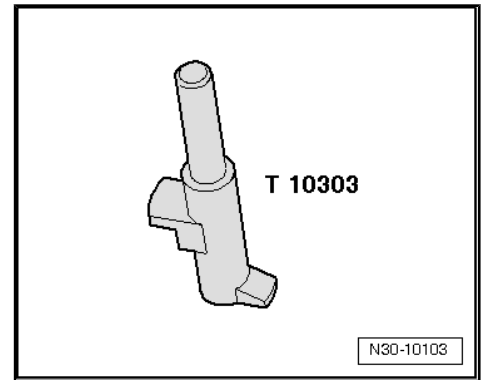

- First set -retaining pin- on seat of cover.

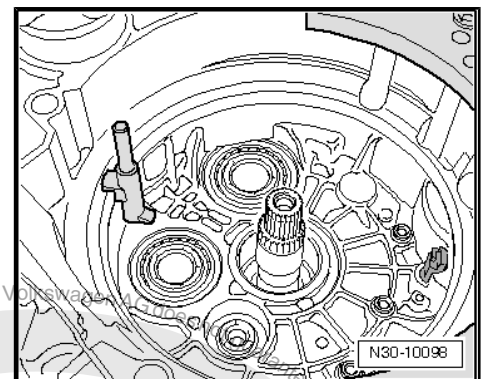

- Then insert -clutch- without letting it fall in.  
Do not mount on clutch. Clutch is inserted with cover as it was when packaged.

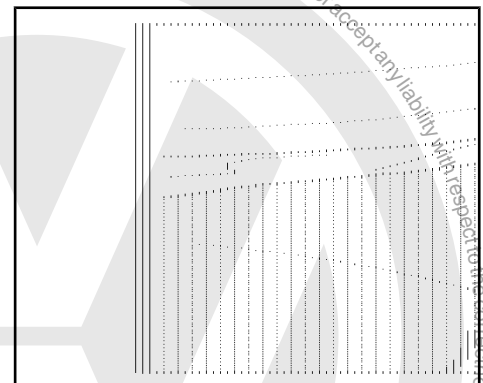

- The -retaining pin- should be held by a second mechanic in the process.

-Retaining pin- remains inserted until all further work has been »completed«.

Do not remove the pin until instructed to do so. But not yet.

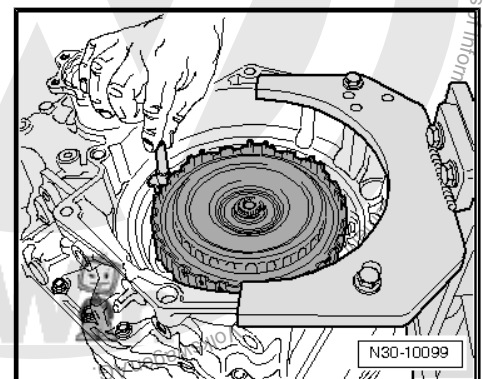



- Carefully remove clutch cover -arrow- from clutch and lay it to side.



**Caution**

*Avoid removing or lifting plate carriers. Not even a little bit! The plates could turn.*

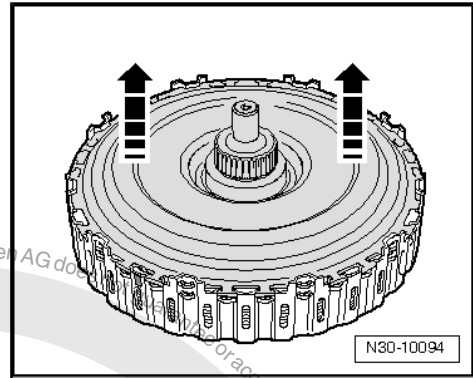

- Select 2 mm retaining ring from among the rings supplied and install it temporarily -arrow-.

Before this ring is removed again, 2 measurements must be made.

**First measurement**

- Retaining pin -T10303- remains in!
- Screw universal dial gauge -VW 387- to gearbox flange.

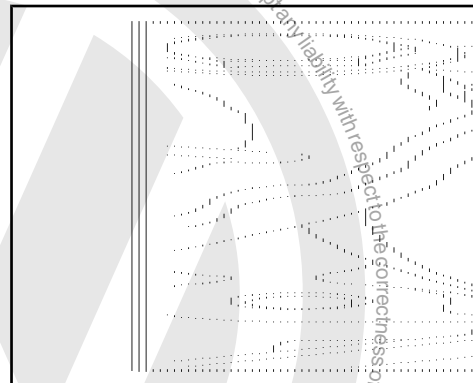

- Set -tip of dial gauge- on input shaft.
- Set -dial gauge- to 0 with preload.
- Raise clutch to stop and note result of measurement.

**Second measurement**

- Retaining pin -T10303- remains in!

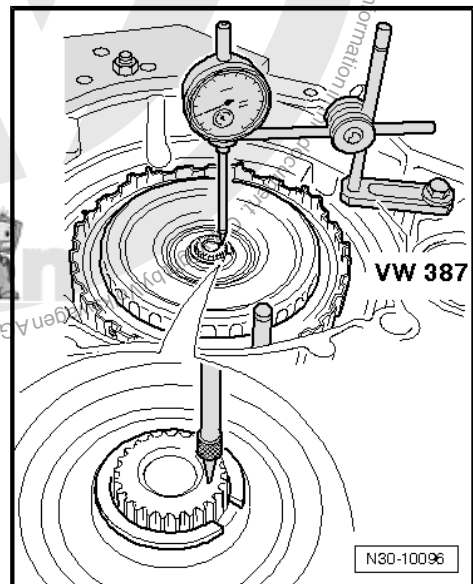



- Set tip of dial gauge -on hub of large plate carrier-.

Tip must not sit on retaining ring.

- Set -dial gauge- to 0 with preload again.
- Raise clutch to stop again and also note this result.

**Now it can be determined which of the remaining 9 rings will ultimately be installed:**

- Use this formula:

Second measurement minus first measurement plus 1.85 mm  
= thickness of ring to be installed

- Please make a note of this result.

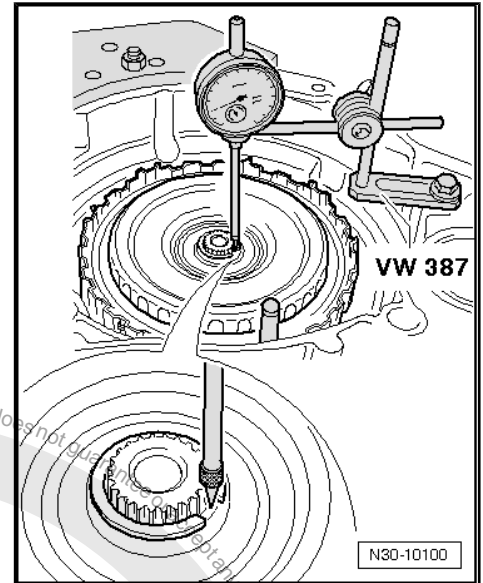

The remaining 9 retaining rings are in increments of 0.1 millimetre.

- Measure all rings and determine which ring is closest to your result.
- Remove 2 mm thick ring and install calculated ring.
- Dispose of all remaining rings and the 2 mm thick ring.

Retaining rings are only allowed to be installed once.

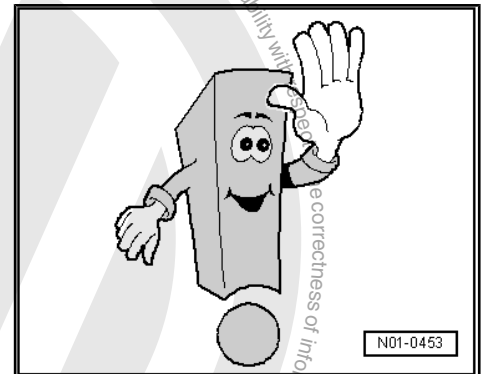

- Insert -pump shaft-.

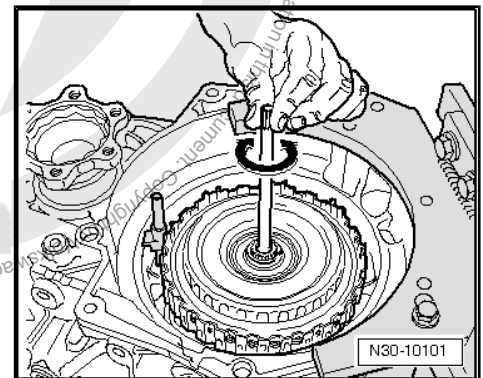



- Install clutch cover so that lug aligns with marking.

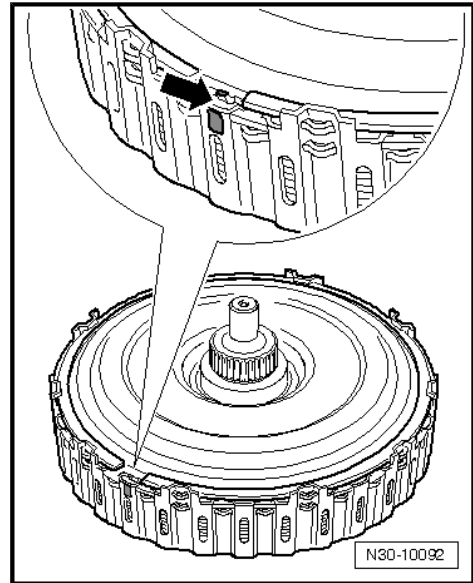

- Then remove retaining pin -T10303- .
- Install cover (end cover) => [page 18](#) .

**This concludes the installation and the clutch is correctly adjusted.**

**After installing gearbox**

- Conduct basic adjustment of mechatronic unit for dual clutch gearbox -J743- .

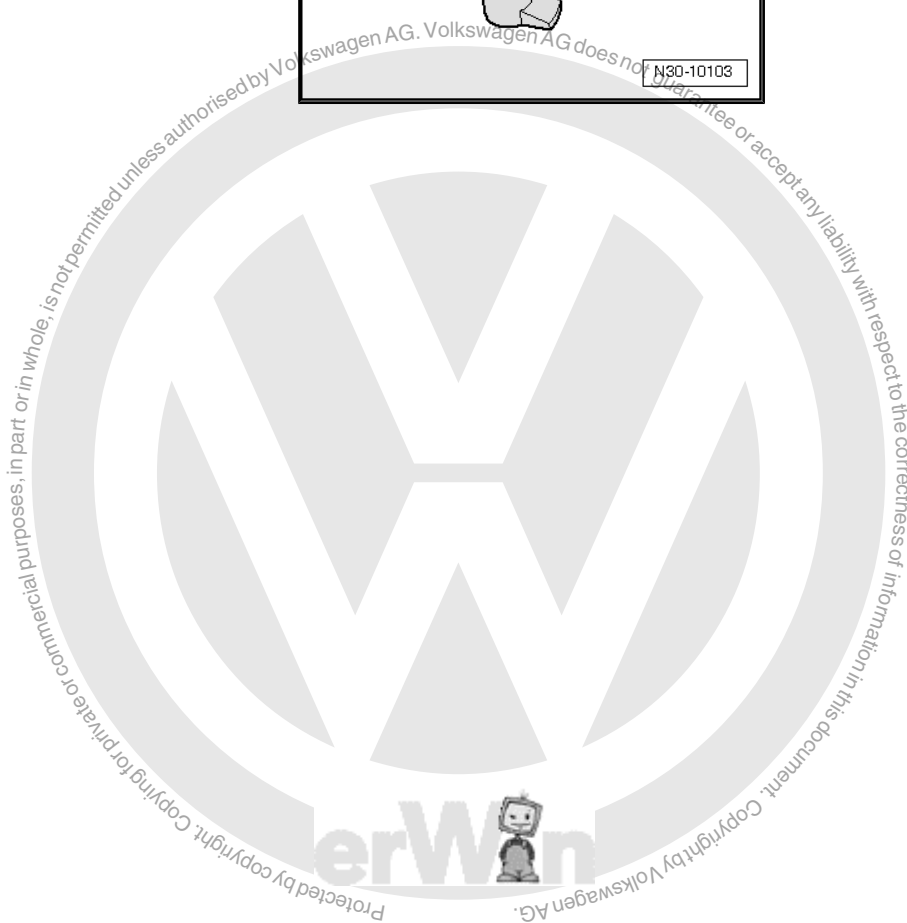
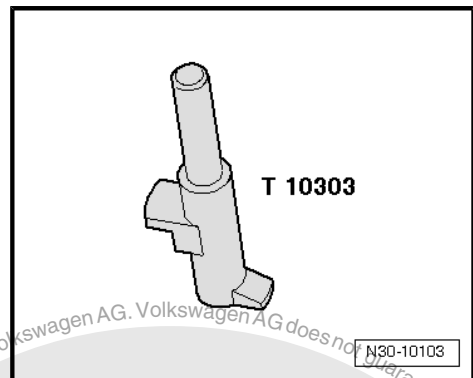



### Special care

The assembly of the multi-clutch requires special care because all components have been balanced together during manufacture. If parts are turned relative to each other, imbalances result which reduce ease of shifting and service life.

#### **If parts of clutch have slipped out or plate carriers have been lifted:**

The large plate carrier »and if necessary, also the small one« can be threaded into all inner plates by hand with gentle turning movements.

Especially the clutch cover should always be installed in the same position as was the case in the »delivery« of the new clutch

⇒ [page 24](#) .



**1 - Multi-clutch housing**

**2 - Seal**

- Qty. 4

**3 - Large plate carrier**

- Do not remove

**⚠ Caution**  
*Avoid removing or lifting plate carrier. Not even a little bit! The plates could turn.*

**4 - Outer plate**

- Qty. 4

**5 - Inner plate**

- Qty. 4

**6 - Thrust washer**

**7 - Retaining ring**

- If retaining ring was removed to insert new plates, it should be renewed with a new, equally thick ring

**8 - Retaining ring**

- This ring must be re-measured each time the clutch is installed

**9 - Clutch cover**

**10 - Retaining ring**

- Always renew
- Do not install corrugated retaining rings

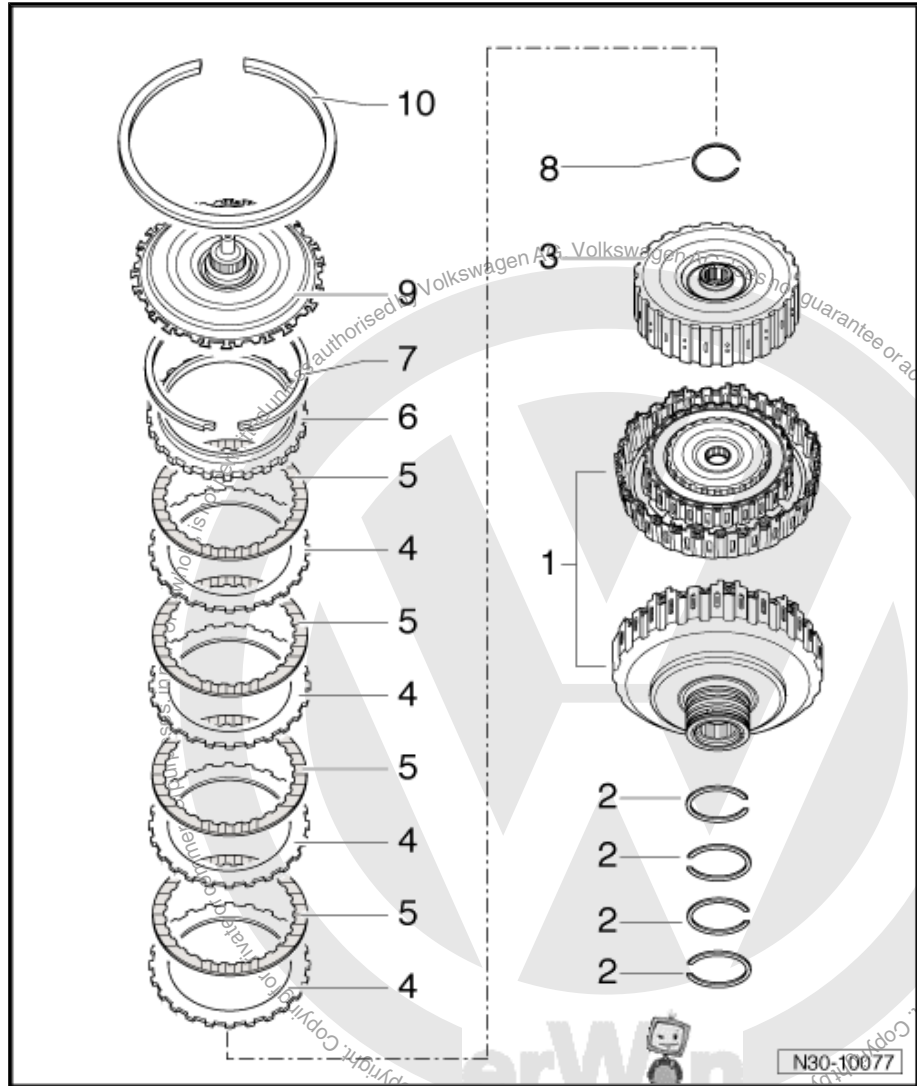



## 34 – Controls, housing

### 1 Electrical and electronic components for the dual clutch gearbox and their locations

There are electrical and electronic components in the gearbox.

Only the selector lever sensors control unit -J587- and the selector lever lock solenoid -N110- are located on the selector lever.

#### 1 - Mechatronic unit for dual clutch gearbox -J743-

- Behind »large« sheet metal cover
- Removing and installing with gearbox installed  
⇒ [page 31](#)
- Removing and installing with gearbox removed  
⇒ [page 40](#)

#### 2 - Gearbox input speed sender -G182- and oil temperature sender in multi-plate clutch -G509-

- Before sender can be removed, mechatronic unit for dual clutch gearbox -J743- must be removed ⇒ [page 31](#).

#### 3 - Selector lever -E313-

- For information about selector lever, see ⇒ [page 60](#) Selector mechanism

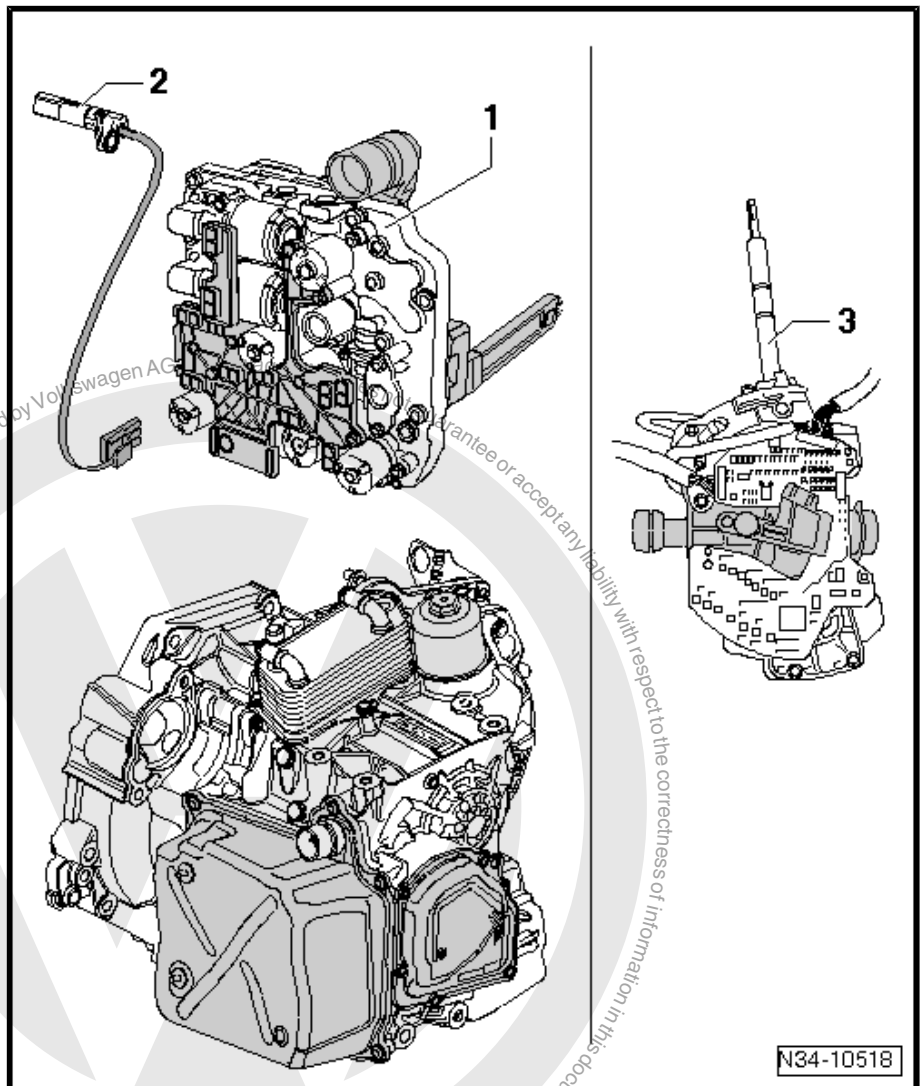

#### 1.1 Removing and installing mechatronic unit for dual clutch gearbox -J743- (gearbox installed)

Removing and installing with gearbox removed ⇒ [page 40](#).

Special tools and workshop equipment required



- ◆ Torque wrench -V.A.G 1331-

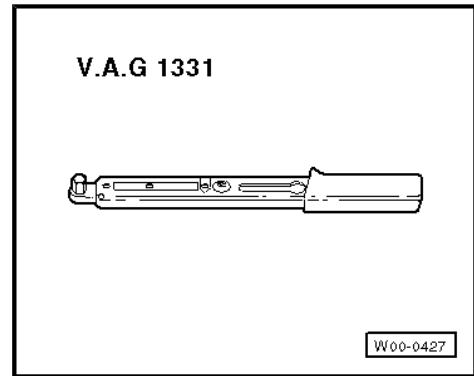

- ◆ Used oil collection and extraction unit -V.A.G 1782-

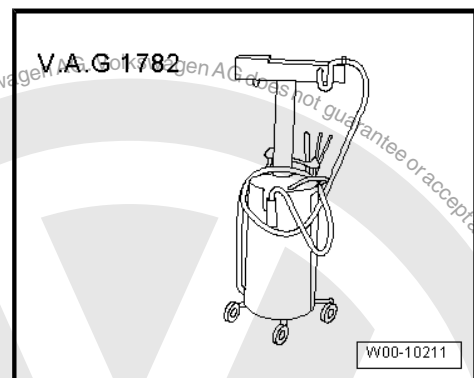

### 1.1.1 Removing mechatronic unit (gearbox installed)

#### Perform the following steps:

Always make sure that no dirt can enter an »open« gearbox.

In particular, dirt entering an »exposed« mechatronic unit for dual clutch gearbox -J743- and/or oil pump can lead to gearbox failure.

Please also refer to the notes on the oil filter change regarding »dirty oil« ⇒ [page 4](#) .

The mechatronic unit can stick on the dowel pins when the gearbox is very warm. Then let the gearbox cool off.

- Move selector lever to position „P“ position.
- With ignition switched off, disconnect battery earth strap ⇒ Electrical system; Rep. gr. 27 ; Disconnecting and connecting battery .
- Remove noise insulation ⇒ General body repairs, exterior; Rep. gr. 50 ; Noise insulation; Assembly overview - noise insulation .

If present:

- Remove connecting hose between charge air cooler and charge air pipe ⇒ Rep. gr. 21 ; Removing and installing parts of charge air cooling .

#### For 1.4 l engines only

- Move lock carrier to service position ⇒ Rep. gr. 50 ; Lock carrier, service position .



Continuation for all vehicles

**i** Note

*It is possible that parts having nothing to do with the mechatronic unit must be removed. This depends on the vehicle's equipment. This will create enough space to remove the mechatronic unit.*

- ◆ Depending on the vehicle, these parts may include, for example,
- ◆ Fan support -arrow-
- ◆ Additional lines for air conditioner
- ◆ Charge air or air cooling pipes

- Remove electrical wiring and retainers -arrows- from front of »large« gearbox cover.

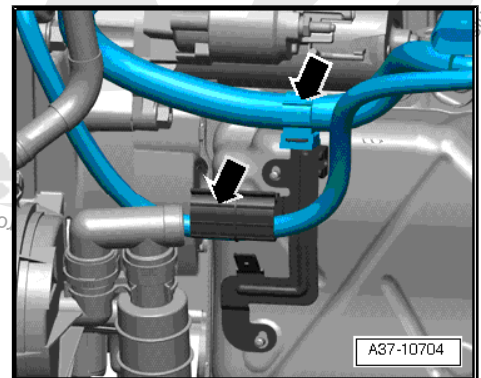
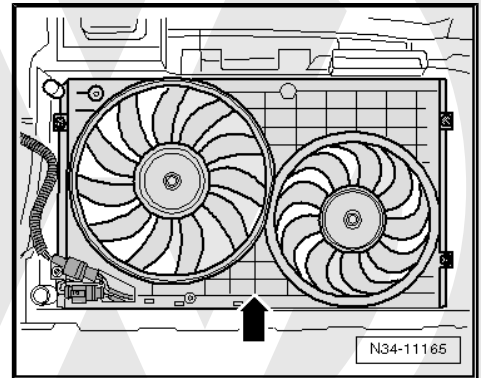

- Release mechatronic unit connector -1- by turning and pull off connector.

**i** Note

*Connector is located close to starter -A- on front of gearbox.*

- Raise lines near cover and tie.
- Position used oil collection and extraction unit -V.A.G 1782- under gearbox.

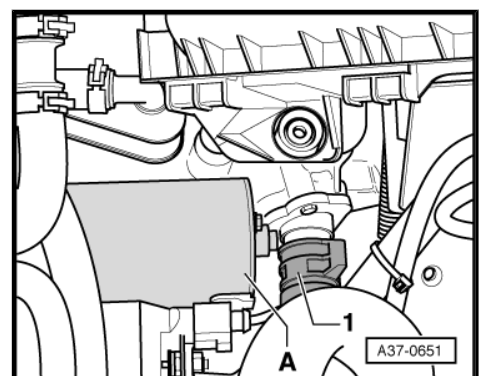

- Remove bolt -A- near pendulum support.

To gearbox manufacture date „20 September 2004“, gearboxes were constructed with 2 plugs.

A plastic overflow tube (with 8 mm hexagon socket head bolt, torque setting 3 Nm) is located in this hole. Its length determines the oil level in the gearbox.

- Remove this oil pipe.

About 5.0 litres of oil will run out. Used oil collection and extraction unit -V.A.G 1782- should remain under gearbox.

- Screw overflow tube back in, 3 Nm.

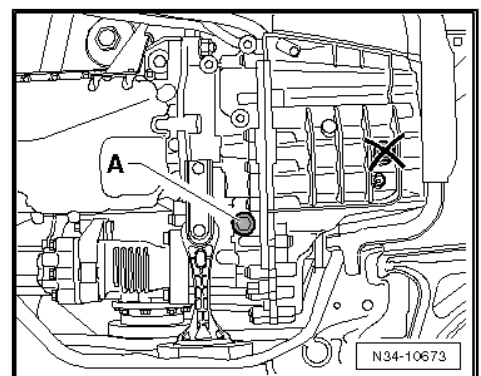



- Loosen bolts -arrows- of cover diagonally and remove.
- Guide cover past starter bolt.
- Remove cover and seal.



#### Note

- ◆ Cover bolts always must be renewed.
- ◆ Likewise, cover seal must also be renewed.

The pendulum support can be removed to make space for removing the mechatronic unit.

This allows the gearbox to be »pushed back« a little.

Before touching mechatronic unit, touch an earthed object  
⇒ [page 6](#) .

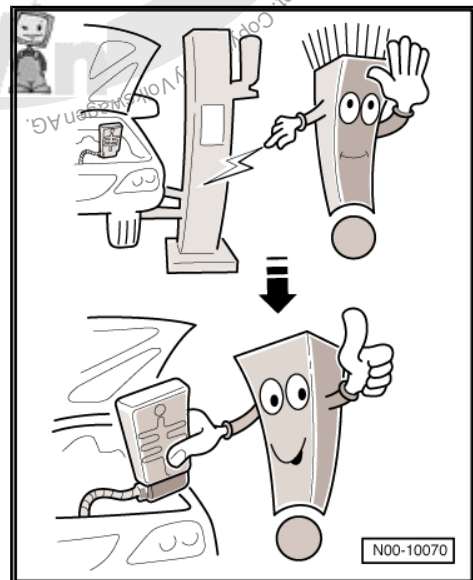
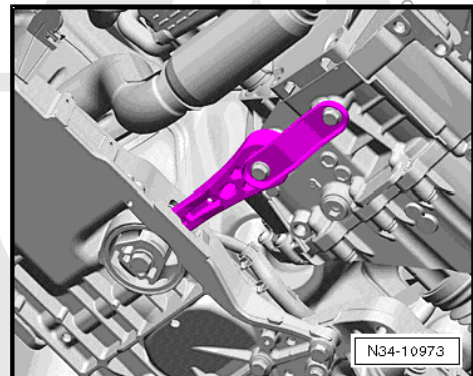
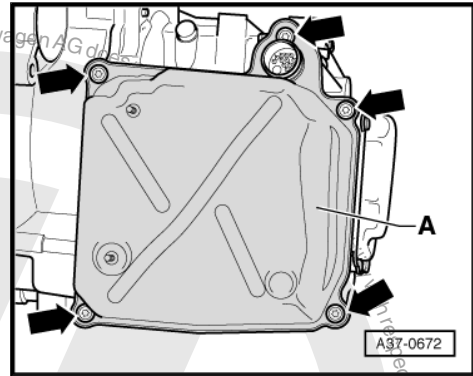



- Carefully release connector of gearbox input speed sender G182- with oil temperature sender in multi-plate clutch -G509- using a small screwdriver -1-.

- Only press onto locking mechanism with screwdriver -1-.
- Do not lever it.

Do not use screwdriver as a lever.

- Use screwdriver -2- to loosen connector.

Be very careful. The fastener of the connector can break. If this happens, the sender must be renewed.

**Do not pull on line!**

- Pull off connector.
- Remove line from retaining lugs -arrows-.

- Loosen securing bolts -1- through -10- in given order and remove.

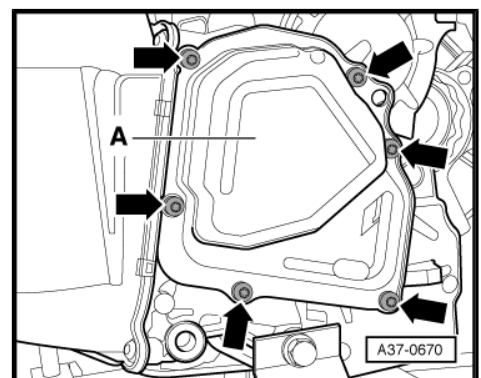
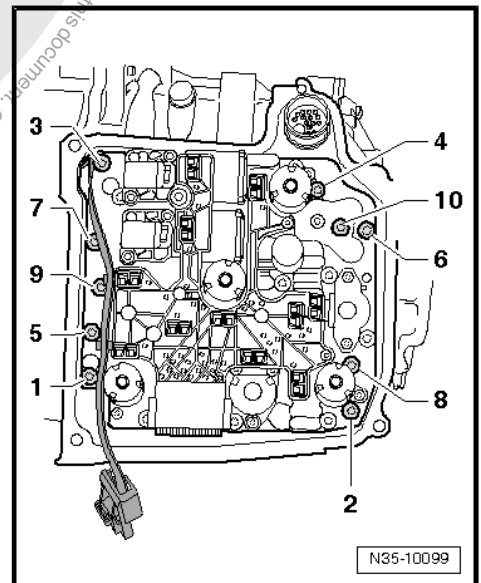
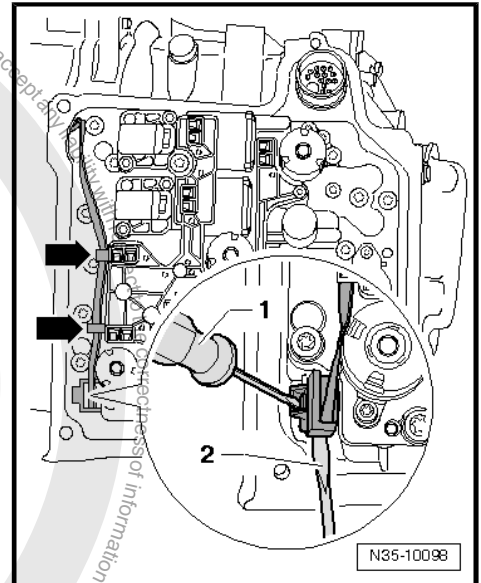

**i Note**

- ◆ *The side cover -A-, cover for oil pump, does not need to be removed in order to remove or install the mechatronic unit.*
- ◆ *For greater clarity, the side cover has been removed in the next illustration.*



- Carefully pull mechatronic unit out of gearbox housing so that sender arm -B- on back is no longer in gearbox housing.

When handling mechatronic unit, pay special attention to the »long« sender arm -B-.

- Carefully swing mechatronic unit for dual clutch gearbox - J743- downwards.

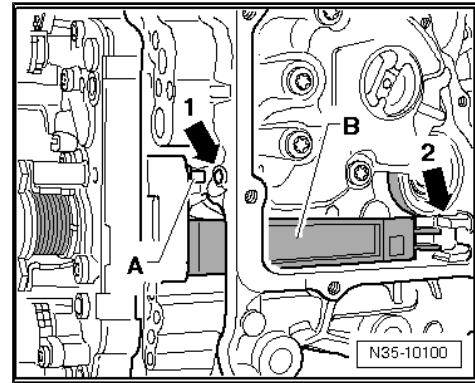

Lay mechatronic unit to side properly.

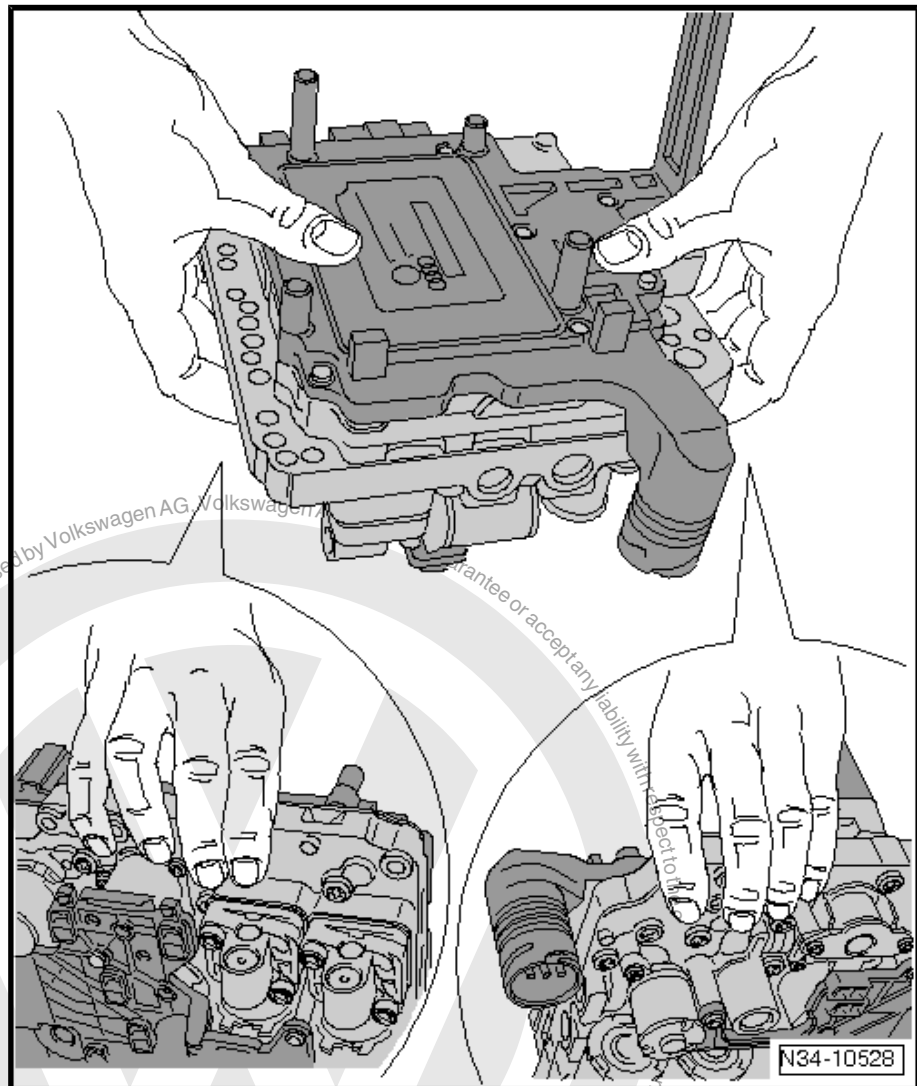

**Caution**

**Never lift mechatronic unit on »sender arm« or lay it on arm.**



If »arm« is damaged, mechatronik unit must be renewed.

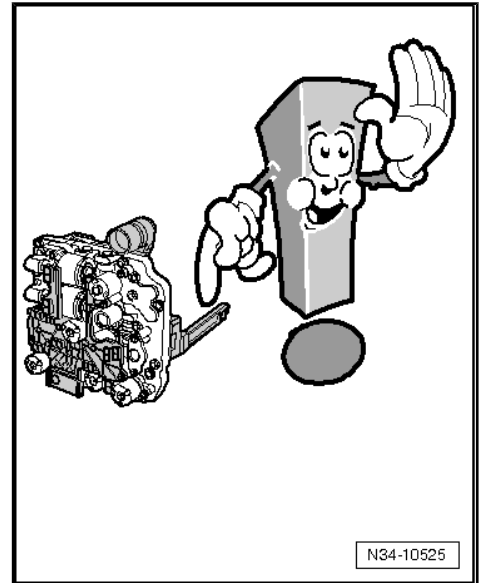

### 1.1.2 Installing mechatronic unit (gearbox installed)

Perform the following steps:

Before touching mechatronic unit, touch an earthed object  
=> [page 6](#) .

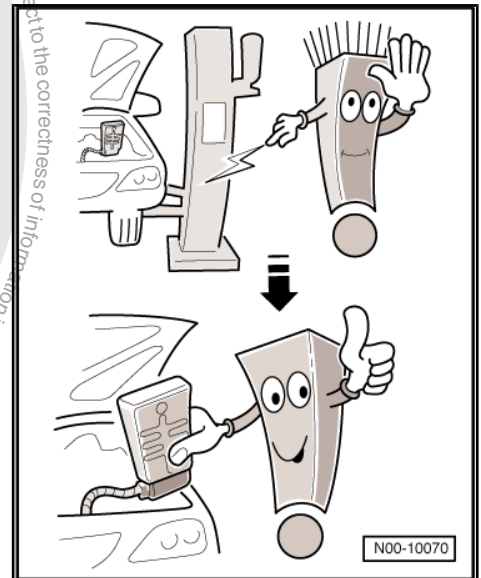



If »arm« is damaged, mechatronic unit must be renewed.

- Carefully set mechatronic unit for dual clutch gearbox -J743- in gearbox housing.



**Note**

- ◆ *The side cover should not be removed in order to remove other parts*
- ◆ *The side cover is not shown in this illustration. This is to make it clear how the »long arm« will be damaged if the mechatronic unit is canted.*

**Mechatronic unit for dual clutch gearbox -J743- and gearbox should be at same temperature. This stops down pins from »jamming« during insertion.**

- Do not pinch wiring.

**Be very careful: do not pinch wiring!**

- Carefully set mechatronic unit on dowel pins -arrow-. Ensure that »sender arm« locates in its -fitting position-.

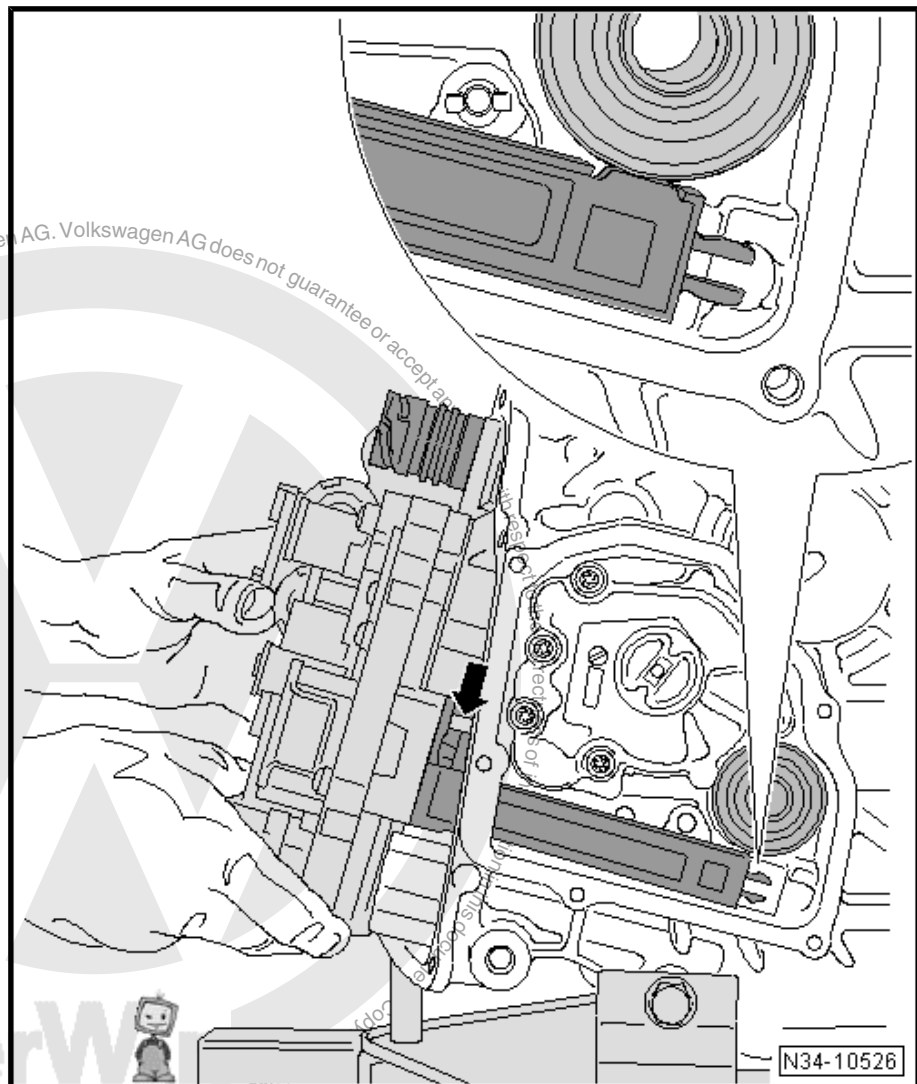
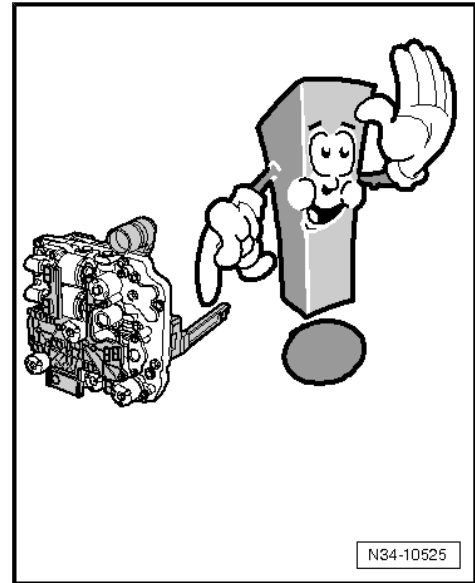



- Hold mechatronic unit upwards for this purpose. Sender arm is not allowed to strike sender wheel. -Detail-
- Look to see if mechatronic unit has made contact correctly.
- Screw in new bolts -1- through -10- hand-tight.
- Tighten bolts in given order to 5 Nm + 90° (1/4 turn).
- Hook line -A- first in upper retaining lug, and then in lower -arrows-.
- Push on connector and engage.

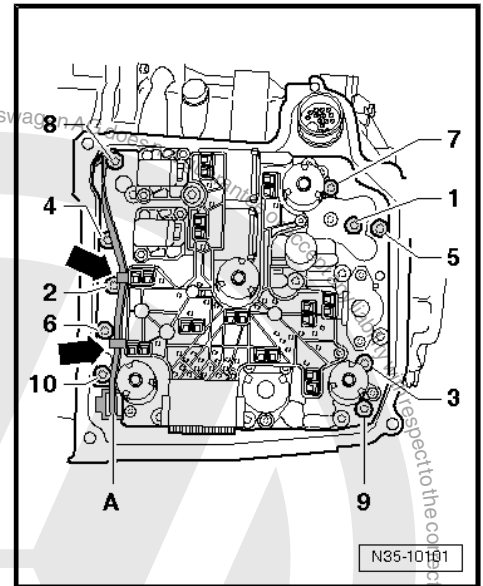

- Renew both -O-rings- if you reinstall the »old« mechatronic unit.
- Moisten O-rings with dual clutch gearbox oil.  
(Of course a »new« mechatronic unit already has »new« seals.)
- Clean cover seal and sealing surfaces on gearbox.
- Ensure proper seating of seal.
- Set cover over mechatronic unit, being careful not to pinch any wiring.

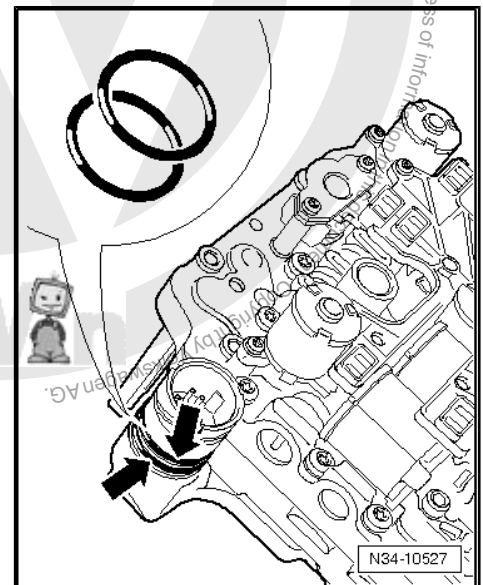

- Insert new bolts -arrows- and tighten diagonally in several stages to 10 Nm.
- Attach wire retainer to cover and tighten nuts to 10 Nm.

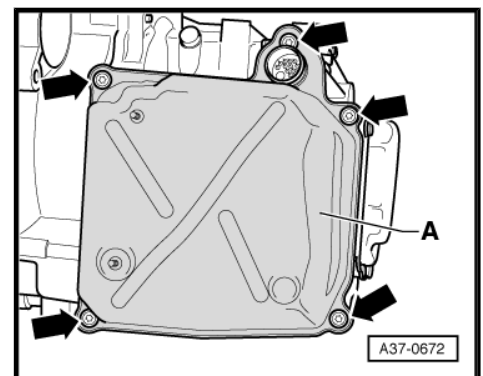



- Push on connector for mechatronic unit for dual clutch gearbox -J743- and engage lock by turning.
- If removed, install connecting hose between charge air cooler and charge air pipe ⇒ Rep. gr. 21 ; Removing and installing parts of charge air cooling .
- Reinstall any parts which may have been removed from the vehicle.
- Connect battery earth ⇒ Electrical system; Rep. gr. 27 ; Disconnecting and reconnecting battery .

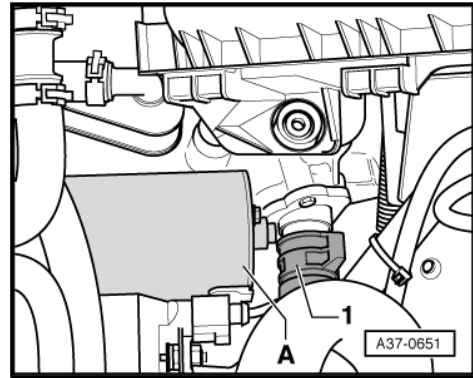

- Do not start engine!
- Please renew filter if oil is contaminated.
- Change oil and filter for dual clutch gearbox ⇒ [page 90](#) .
- Install noise insulation ⇒ General body repairs, exterior; Rep. gr. 50 ; Noise insulation; Assembly overview - noise insulation .

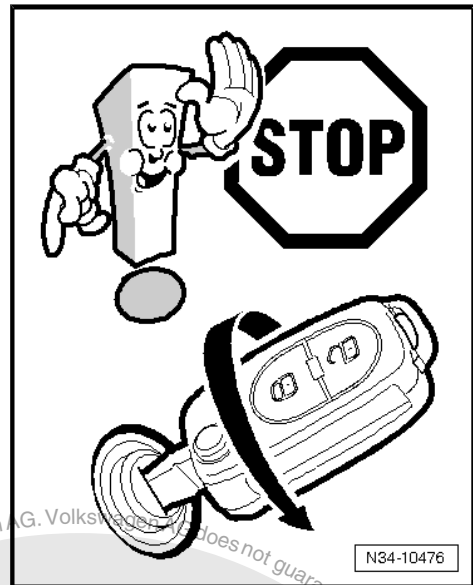

- Conduct basic adjustment of mechatronic unit for dual clutch gearbox -J743- .

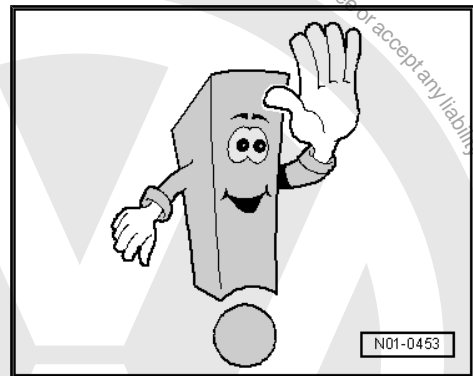

## 1.2 Removing and installing mechatronic unit for dual clutch gearbox -J743- (gearbox removed)

Special tools and workshop equipment required



- ◆ Torque wrench -V.A.G 1331-

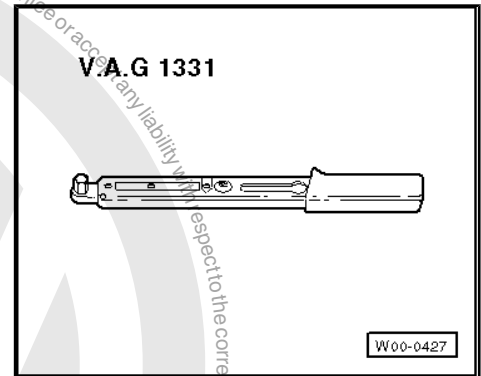

- ◆ Used oil collection and extraction unit -V.A.G 1782-

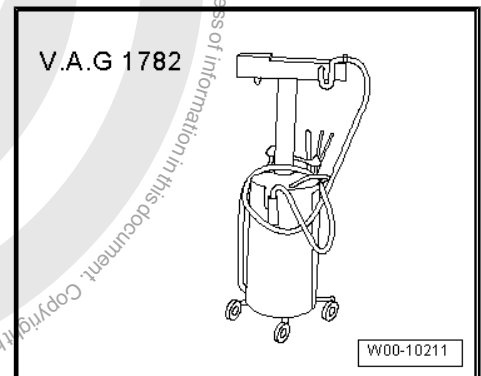

Always make sure that no dirt can enter an »open« gearbox. In particular, dirt entering an »exposed« mechatronic unit for dual clutch gearbox -J743- and/or oil pump can lead to gearbox failure.

Please also refer to the notes on the oil filter change regarding »dirty oil« ⇒ [page 4](#) .

### 1.2.1 Removing mechatronic unit (gearbox removed)

Perform the following steps:

- Remove bolt -A- near pendulum support.

To gearbox manufacture date „20 September 2004“, gearboxes were constructed with 2 plugs.

A plastic overflow tube (with 8 mm hexagon socket head bolt, torque setting 3 Nm) is located in this hole. Its length determines the oil level in the gearbox.

- Position used oil collection and extraction unit -V.A.G 1782- or a drip tray under gearbox.
- Remove this oil pipe.
- Drain oil.

Please also refer to the notes on the oil filter change ⇒ [page 4](#) regarding »dirty oil«.

- Screw in overflow pipe with 3 Nm torque.

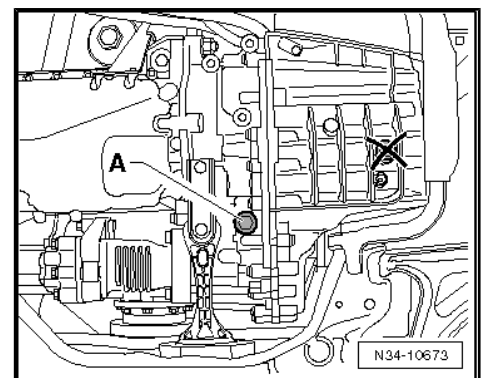



- Remove the filter if necessary.

Often, doubts arise as to whether the filter must be renewed or not.

The notes on the oil filter change ⇒ [page 4](#) can help you in reaching this decision.

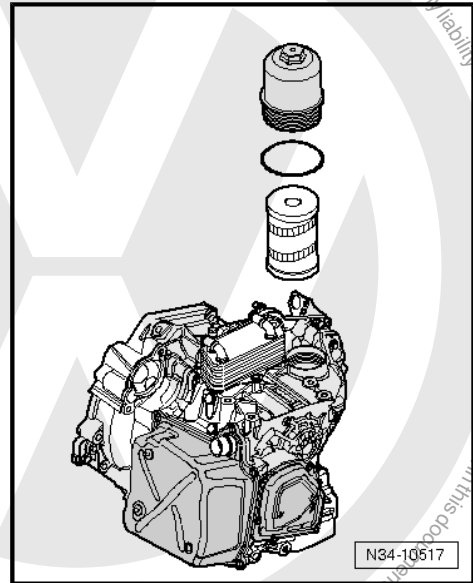

- Insert new filter with shoulder downwards and tighten cover to 20 Nm.
- Following repair work, it is not necessary to change filter again when filling oil.

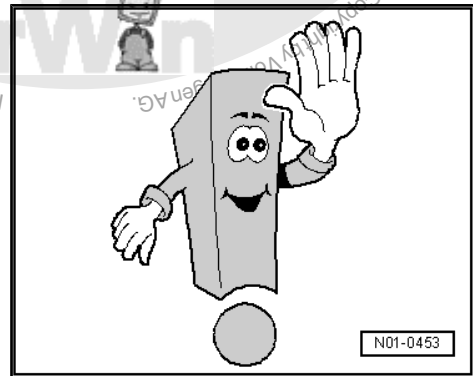

- Remove both -covers-.

»Small« cover of oil pump and bolts of »large« cover must always be renewed.

Likewise, seal of »large« cover must be renewed.

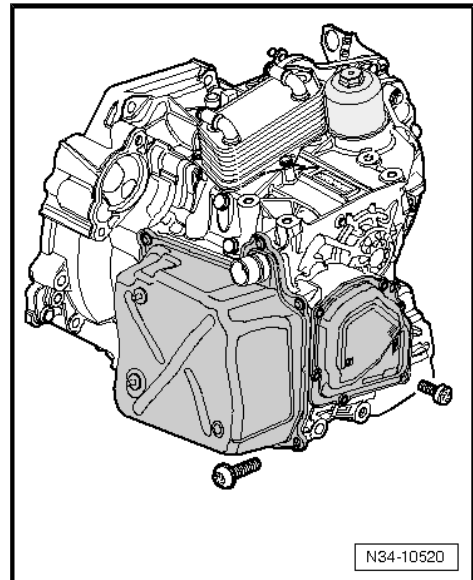



Before touching mechatronic unit, touch an earthed object  
 ⇒ [page 6](#) .

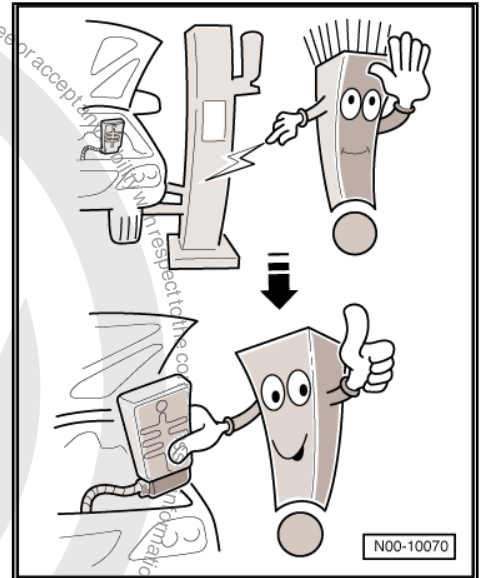

- Carefully release connector of gearbox input speed sender - G182- with oil temperature sender in multi-plate clutch -G509- using a small screwdriver -1-.

- Using a screwdriver -1-, only press against locking mechanism, do not lever.

Do not use screwdrivers as a lever.

- With a second screwdriver -2-, loosen connector.

Take the utmost care. The fastener of the connector can break. If this happens, renew the sender.

**Do not pull on line!**

- Pull off connector.

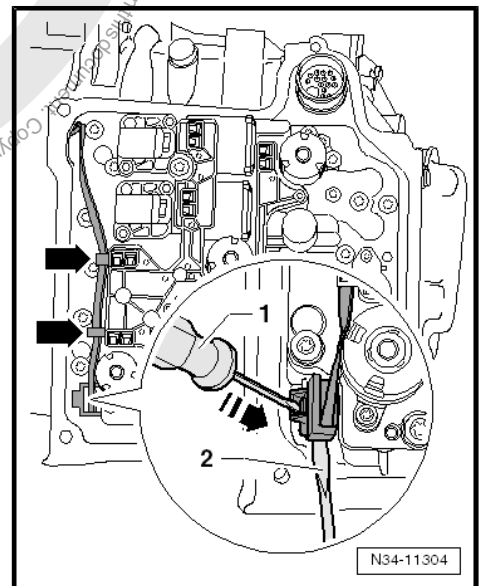

- First pull line out of lower clip -arrow I-.
- Then remove it from upper clip -arrow II- and lay to side. Do not kink line.

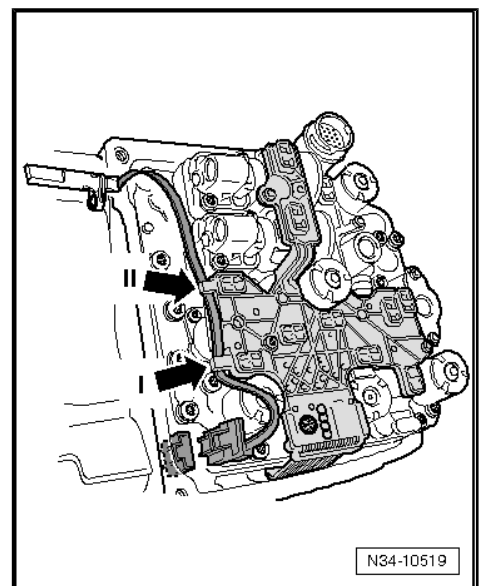



- Remove securing bolts -1 ... 10- diagonally. Start with bolt -1-.

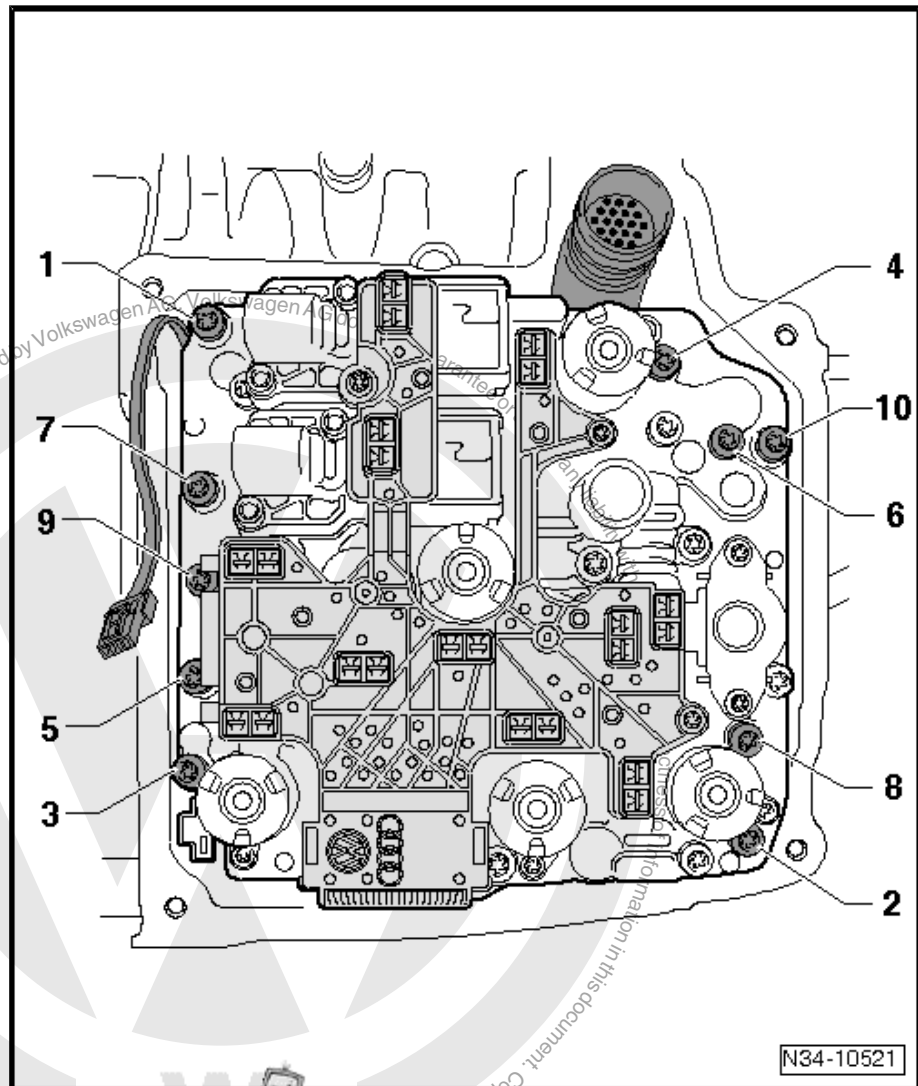

All 10 -securing bolts- must be renewed.

- Remove mechatronic unit for dual clutch gearbox -J743- .

When handling mechatronic unit, pay special attention to the »long« sender arm.



**Caution**

***Never lift mechatronic unit on »sender arm« or lay it on arm.***

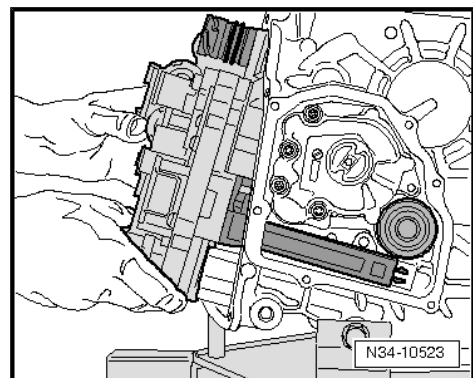



If »arm« is damaged, mechatronic unit must be renewed.

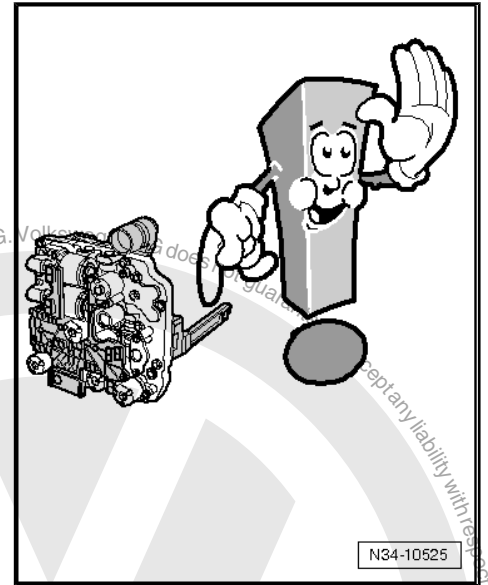

Lay mechatronic unit to side properly.

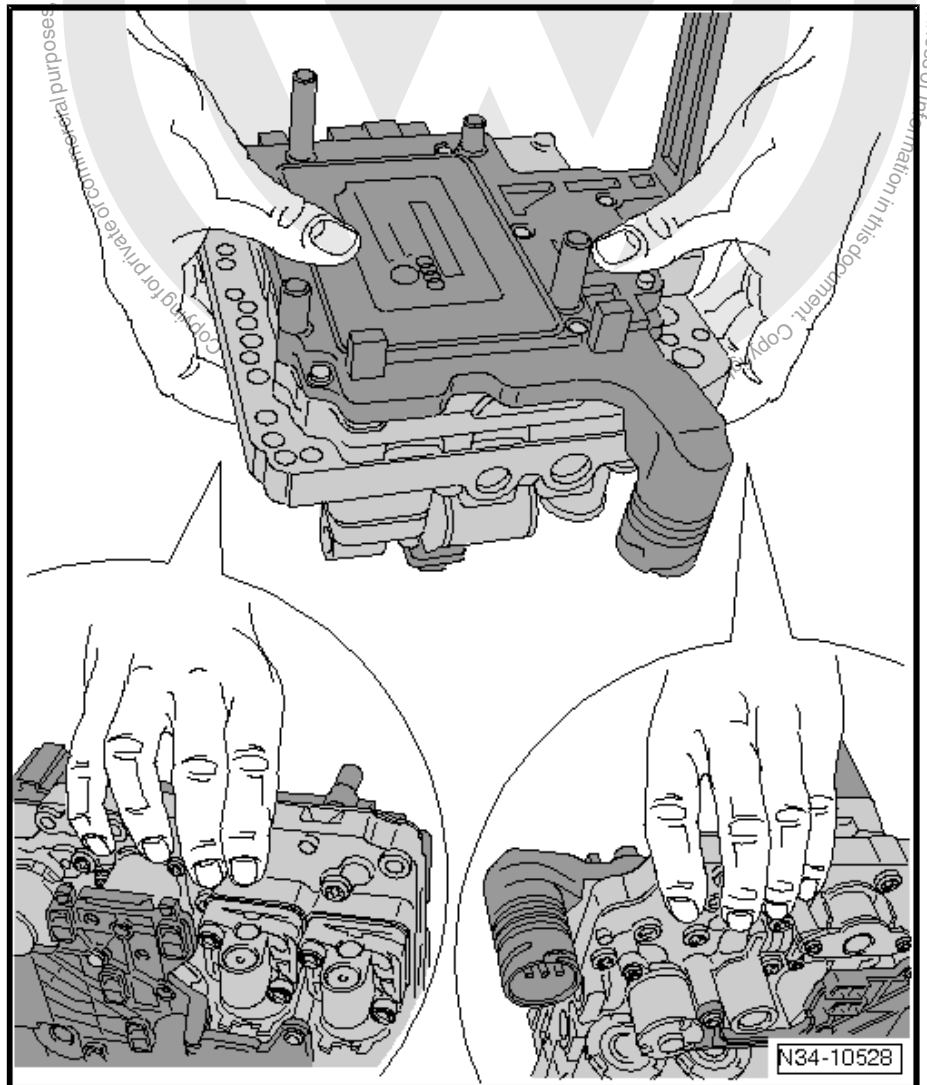



## 1.2.2 Installing mechatronic unit (gearbox removed)

Perform the following steps:



Caution

*Never lift mechatronic unit on »sender arm« or lay it on arm.*

If »arm« is damaged, mechatronic unit must be renewed.

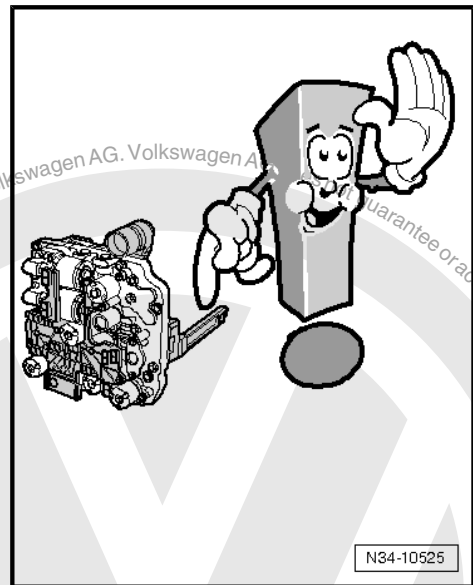

- Before installation, make certain that gearbox input speed sender -G182- with oil temperature sender in multi-plate clutch -G509- is installed.

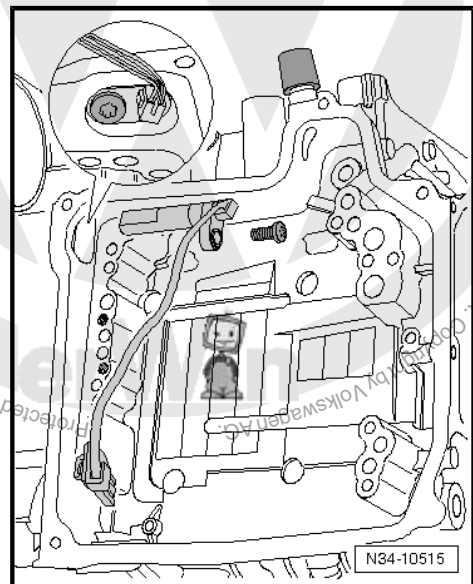



- Renew both -O-rings- at connection for mechatronic unit if you refit an »old« mechatronic unit.  
(Of course a »new« mechatronic unit already has »new« seals.)
- Moisten O-rings with dual clutch gearbox oil.

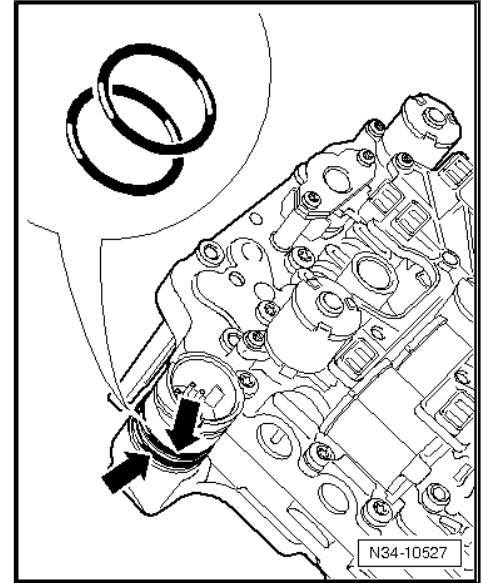

- Carefully set mechatronic unit on dowel pin -arrow-. Ensure that »sender arm« locates in its -fitting position-

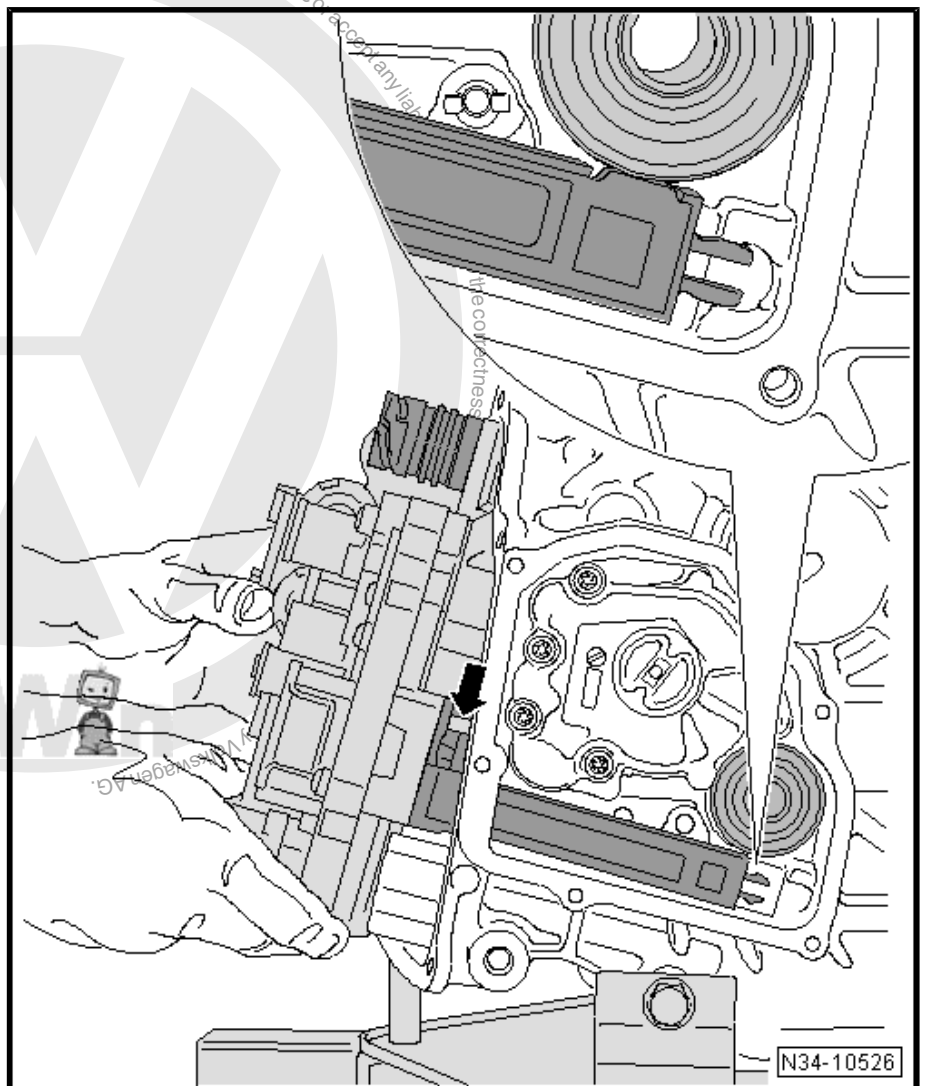



- Sender arm is not allowed to strike sender wheel. -Detail-
- Do not pinch wiring.

**Be very careful: do not pinch wiring!**

All securing bolts -1 ... 10- must be renewed.

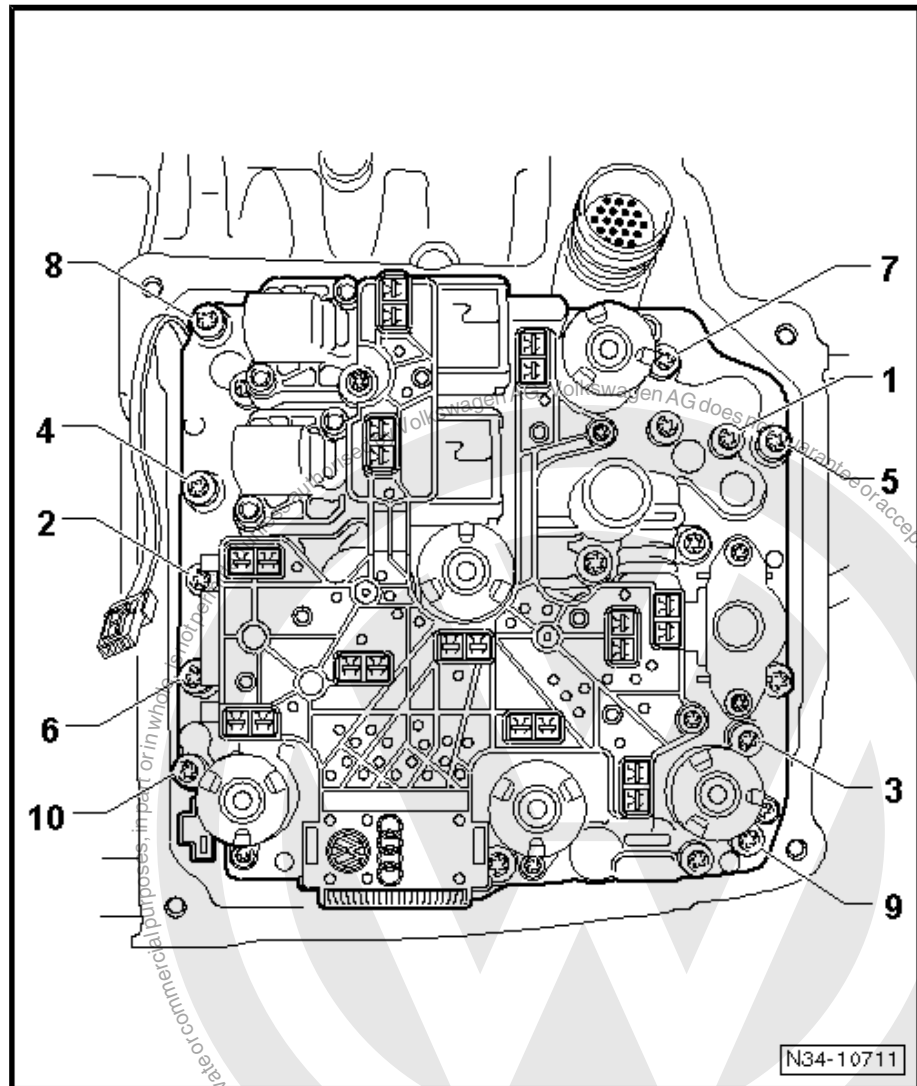

- First start all securing bolts -1 ... 10- »by hand«.
- Then tighten all securing bolts -1 ... 10- diagonally to 5 Nm and then turn 90° further in the same sequence. Start with bolt -1-.



- First press wiring for gearbox input speed sender -G182- with oil temperature sender in multi-plate clutch -G509- into upper clip -arrow II-. Then into lower clip -arrow I-.
  - Press connection onto mechatronic unit.
- »Small« cover of oil pump and bolts of »large« cover must always be renewed.

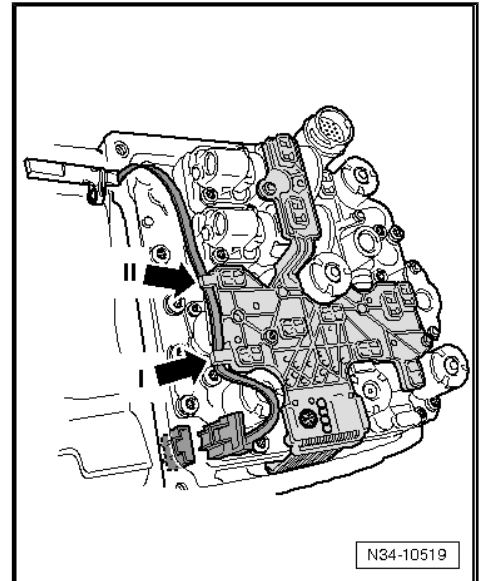

Likewise, -seal- of »large« -cover- must be renewed.

- Tighten cover bolts »diagonally« to 10 Nm.

#### After installing gearbox

- Fill with oil without renewing filter => [page 90](#) .
- Conduct basic adjustment of mechatronic unit for dual clutch gearbox -J743- .

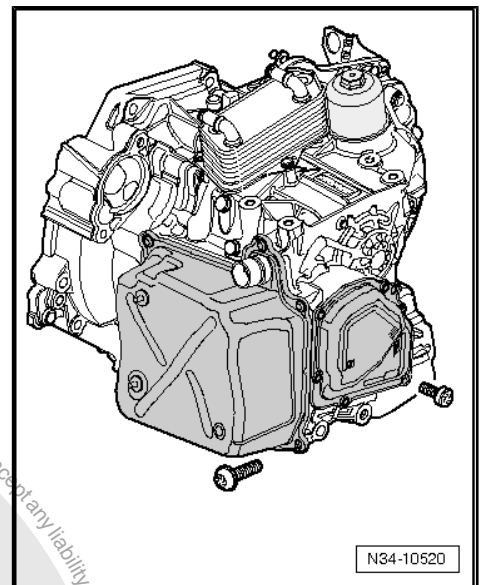

### 1.3 Removing and installing gearbox input speed sender -G182- and oil temperature sender in multi-plate clutch -G509-

#### Perform the following steps:

Both senders are combined in one component and can be renewed together only. They are »bathed in oil« in gearbox near the multi-clutch. Before removal, the mechatronic unit for dual clutch gearbox -J743- must be removed.

It often occurs that the wiring for the sender is pulled. The sender will be damaged. Consequently, if the cable is pulled on, the sender must be renewed.

#### Removing

- Remove mechatronic unit for dual clutch gearbox -J743- => [page 31](#) .

Do not pull on line!

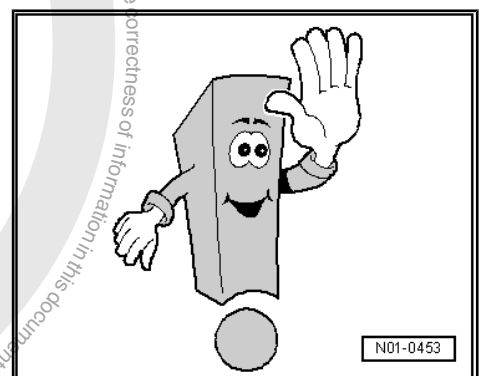



- Remove bolt and carefully lever out sender with a screwdriver and/or pliers.

### Installing

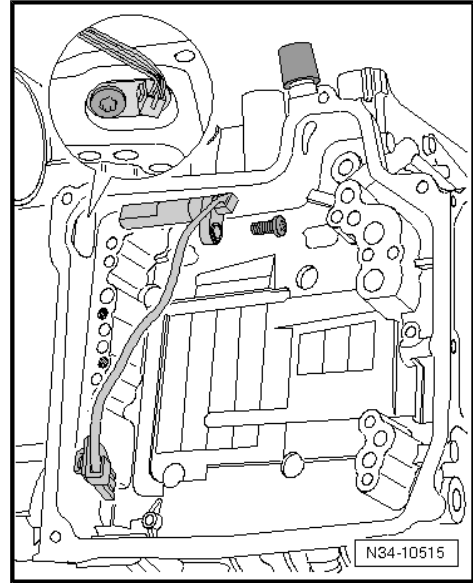

Reinstall »old« sender only if you know for certain:

- The sender has no defect.
- The cable was not pulled on when it was removed.

If this is not the case, install a »new« sender.

- Moisten sender with dual clutch gearbox oil and insert.
- Tighten bolt to 10 Nm.
- Install mechatronic unit for dual clutch gearbox -J743-  
[=> page 31](#) .

**Take special care:**

**Never pinch mechatronic unit wiring during installation!**

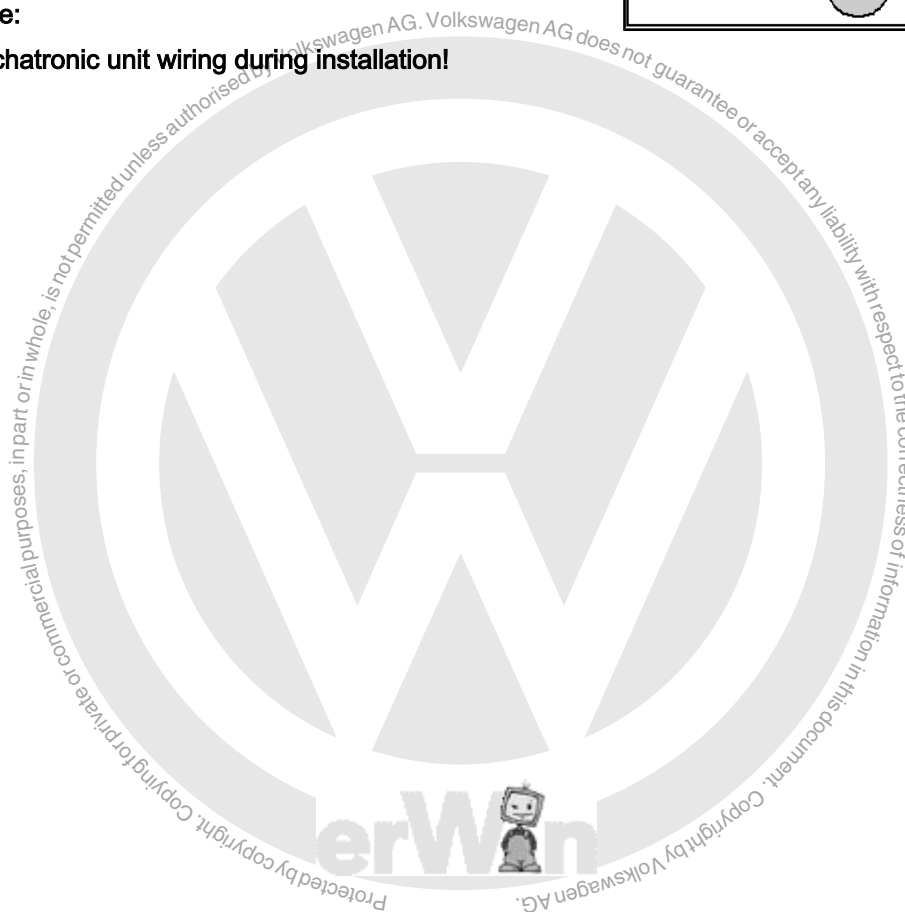
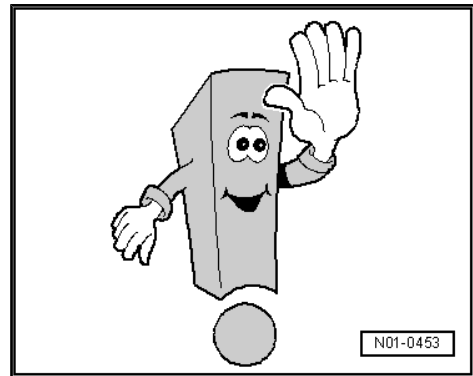



## 2 Removing and installing gearbox oil cooler

### Special tools and workshop equipment required

- ◆ Hose clamps -3094-

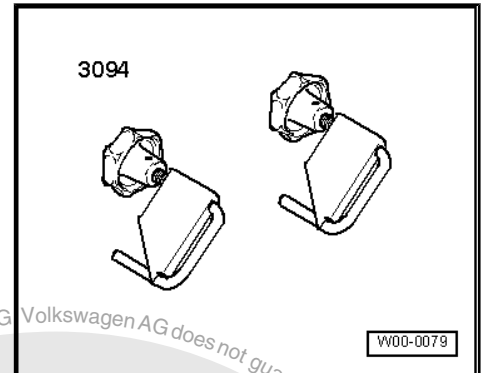

- ◆ Torque wrench -V.A.G 1331-

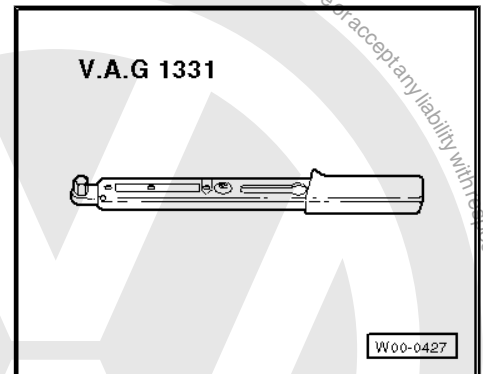

### 2.1 Removing gearbox oil cooler

#### Perform the following steps:

- Move selector lever to position „P“ position.
- Remove battery and battery tray ⇒ Electrical system; Rep. gr. 27 ; Battery; Removing and installing battery .
- Lay lint-free cloths on gearbox oil cooler and gearbox to catch escaping coolant.
- Clamp off coolant hoses using hose clamps -3094- and remove from gearbox oil cooler.

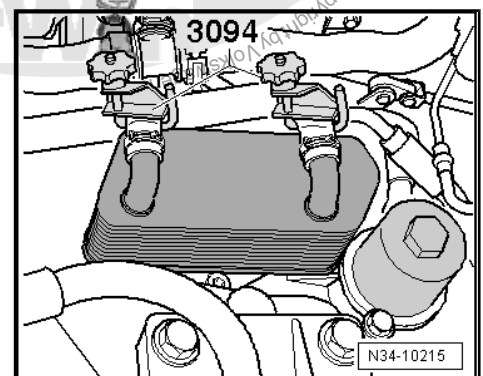



- Remove bolts -A- and remove gearbox oil cooler -B-.



**Caution**

**No coolant must be allowed to drip into gearbox!**

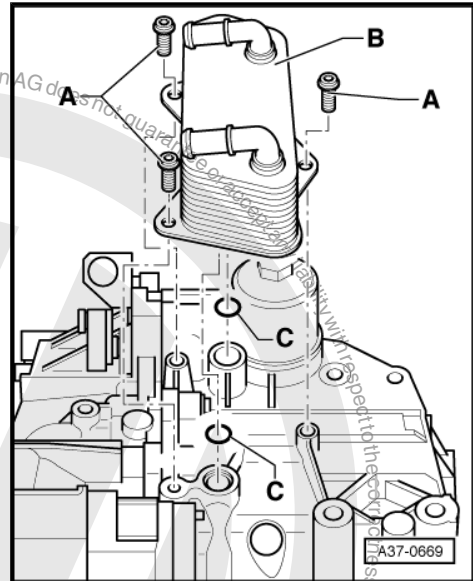

## 2.2 Installing gearbox oil cooler

Perform the following steps:

- Renew O-rings -C- of gearbox oil cooler -B-.
- Set gearbox oil cooler -B- in place, observing O-rings -C-.
- Screw in new bolts -A- and tighten to 20 Nm + 90° (1/4 turn).

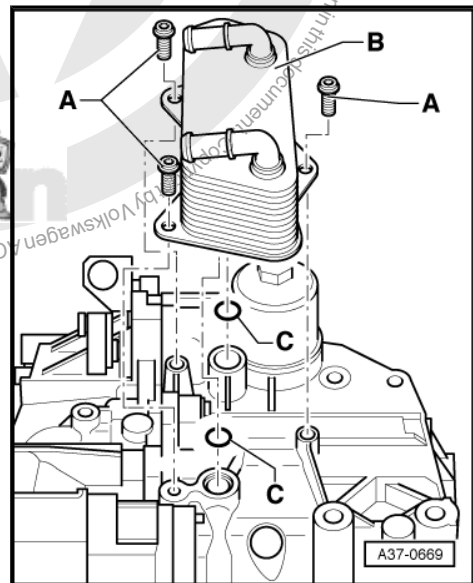

- Attach coolant hoses to gearbox oil cooler and remove hose clamps -3094- .

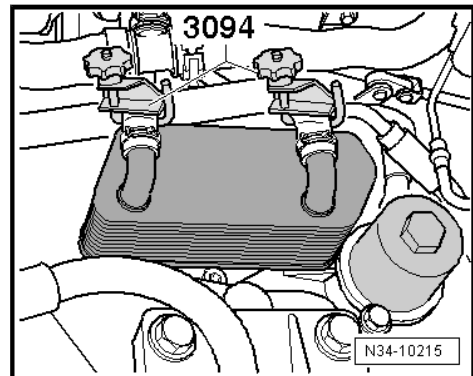



- Insert new filter with shoulder downwards and tighten cover to 20 Nm.
- Following repair work, it is not necessary to change filter again when filling oil.
- Install battery tray and battery⇒ Electrical system; Rep. gr. 27 ; Removing and installing battery .

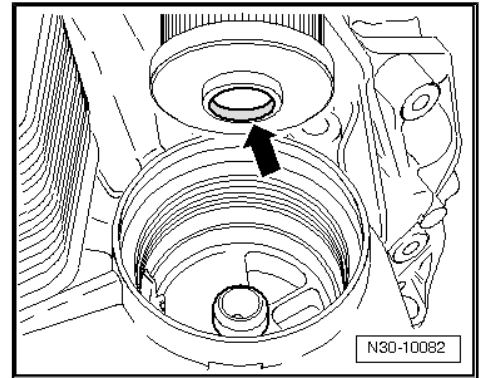

- Check coolant level and top up with coolant as needed ⇒ Rep. gr. 19 ; Removing and installing parts of cooling system .
- Following repairs, fill with oil without renewing filter ⇒ [page 90](#) .



**Caution**

*Do not start engine while checking coolant level if gearbox oil has not yet been filled.*

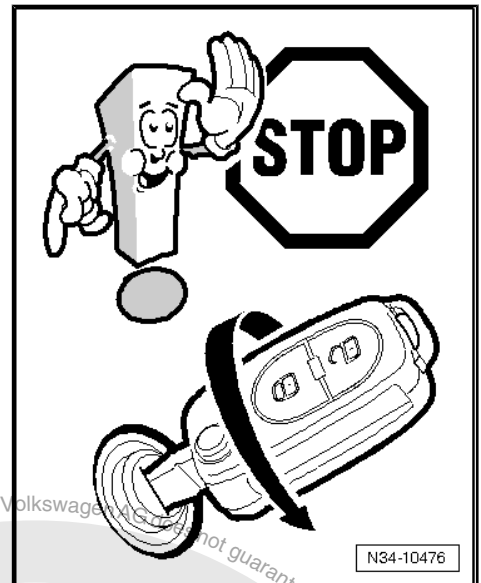



### 3 Removing and installing oil pump

#### Important information

From our experience at Volkswagen too date: you would not have received the instructions for removal of the pump.

Nevertheless, a wish has been expressed for removal and installation instructions.

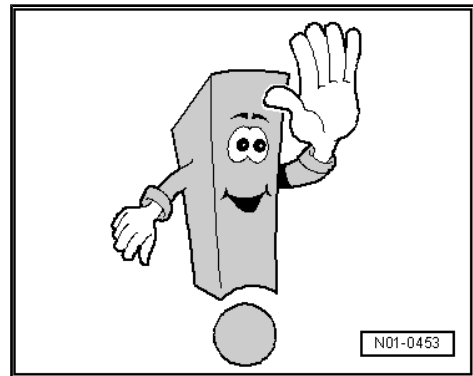

#### Special tools and workshop equipment required

- ◆ Torque wrench -V.A.G 1331-

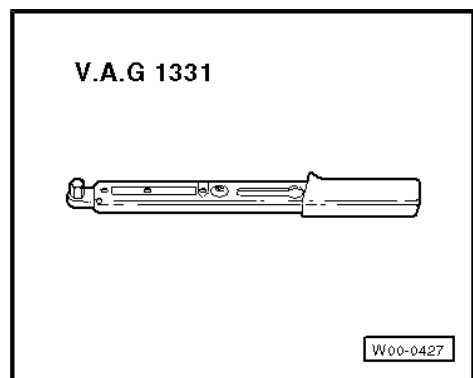

- ◆ Used oil collection and extraction unit -V.A.G 1782-

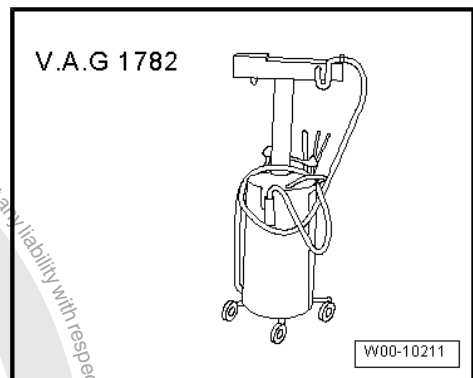

### 3.1 Removing oil pump

#### Brief description

The oil pump can be renewed without the gearbox being removed. The vehicle must be raised and any covers present beneath the front part of the vehicle must be removed. The connection between suspension link and suspension strut does not need to be separated. The drive shaft does not need to be removed. You do not need to perform any „basic adjustment“. Only the dual clutch gearbox oil and oil pump cover must be renewed.

- Remove noise insulation ⇒ General body repairs, exterior; Rep. gr. 50 ; Noise insulation; Assembly overview - noise insulation .
- Remove lower part of front left wheel housing liner ⇒ General body repairs, exterior; Rep. gr. 66 ; Wheel housing liner; Assembly overview - front wheel housing liner .



- Position used oil collection and extraction unit -V.A.G 1782- under gearbox.

Please also refer to the notes on the oil filter change regarding »dirty oil« => [page 4](#) .

- Remove bolt -A- near pendulum support.

To gearbox manufacture date „20 September 2004“, gearboxes were constructed with 2 plugs.

A plastic overflow tube (with 8 mm hexagon socket head bolt, torque setting 3 Nm) is located in this hole. Its length determines the oil level in the gearbox.

- Remove this oil pipe.
- Drain oil.
- Screw in overflow pipe with 3 Nm torque.

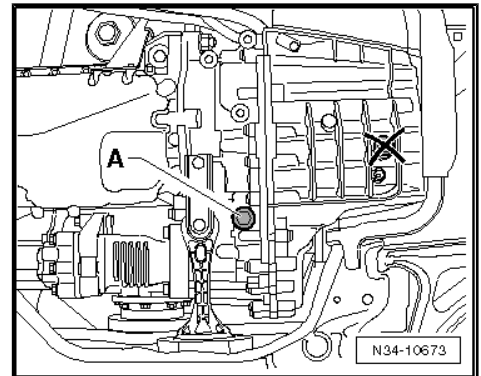

- Renew seal -arrow- for plug.
- Used oil collection and extraction unit -V.A.G 1782- remains under gearbox.

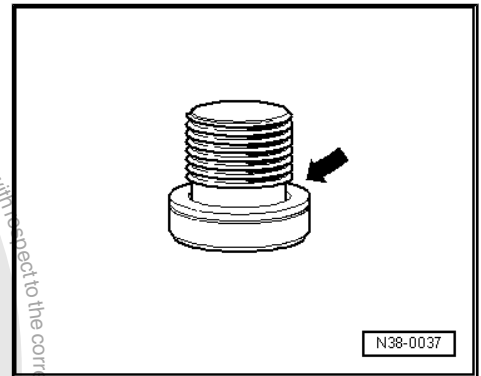

- Remove bolts -arrows- and remove oil cooler cover -A-.
- There will still be oil in oil pump cover.**

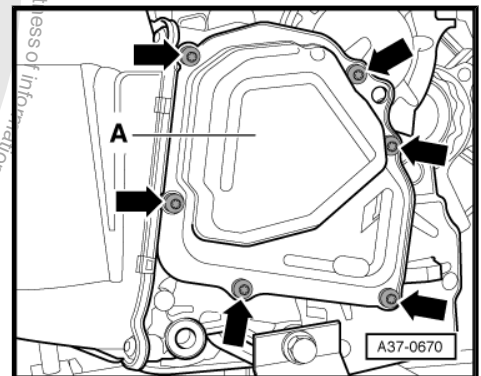

- Remove bolts -arrows- and pull oil pump -1- off dowel pins and pull out oil pump drive shaft.

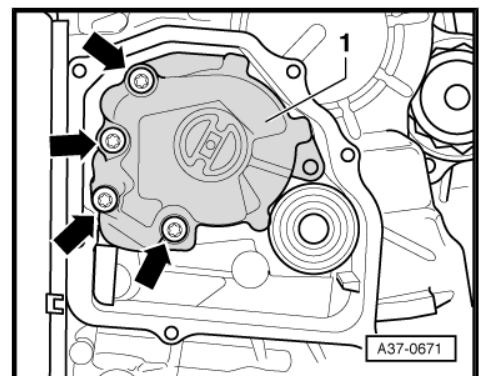



It may be necessary to use socket -T10054- to remove upper bolt.

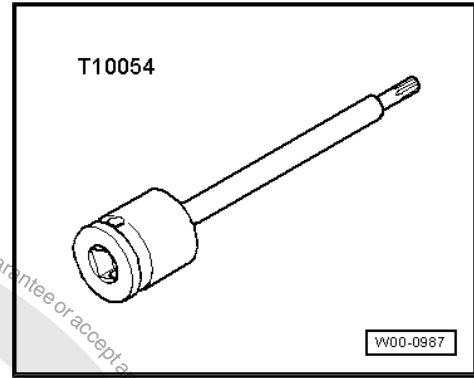

### 3.2 Installing oil pump

- Push input shaft -A- for oil pump into gearbox as far as stop. Turn input shaft slightly whilst doing this.
- Always use a new metal seal -B-.
- The 2 dowel pins -C- must be located in gearbox housing.
- When fitting oil pump, observe splines of input shaft and proper seating of dowel pins.

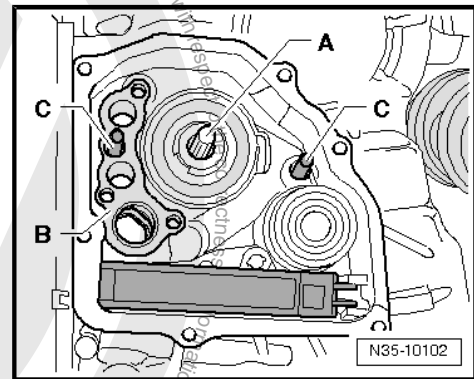

#### Various bolts for oil pump -1-

All 4 bolts with flat heads -arrows-

Torque setting

- ◆ 5 Nm + 90° (1/4 turn)

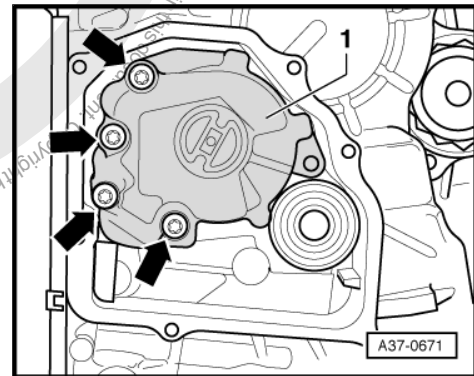

3 bolts with flat heads, uppermost bolt -arrow- with countersunk head

Torque setting

- ◆ Countersunk head bolt: 8 Nm without additional turn (tighten with socket -T10054- )
- ◆ Flathead bolts: 8 Nm + 90° (1/4 turn)

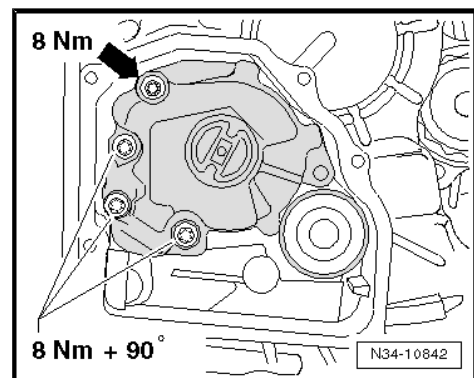



- Set new oil pump cover -A- in place and tighten new bolts -arrows- diagonally in several stages to 8 Nm.

There is no oil in the gearbox. »New« oil must now be filled and adjusted to the proper level.

- Change oil and filter for dual clutch gearbox ⇒ [page 90](#) .
- Install left wheel housing liner ⇒ General body repairs, exterior; Rep. gr. 66 ; Wheel housing liners; Assembly overview - front wheel housing liner
- Install noise insulation ⇒ General body repairs, exterior; Rep. gr. 50 ; Noise insulation; Assembly overview - noise insulation .

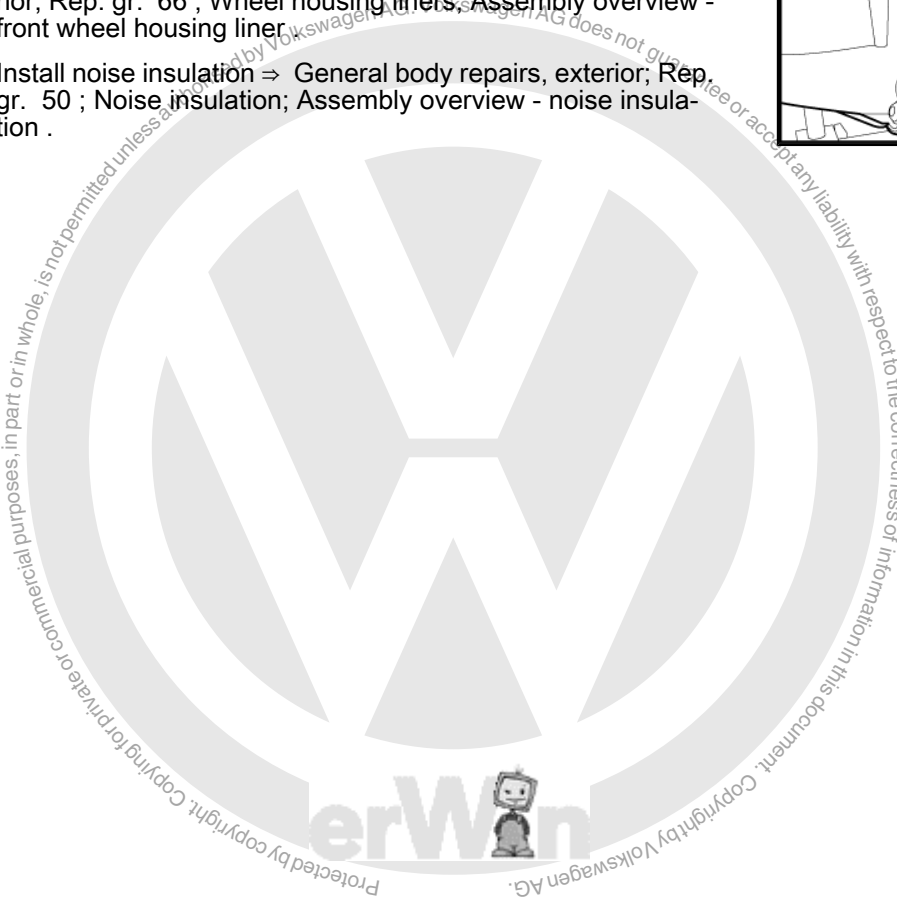
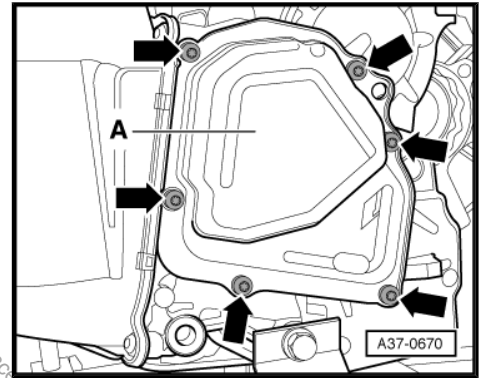



## 4 Renew seal on selector shaft lever

Special tools and workshop equipment required

- ◆ Tube -VW 423-

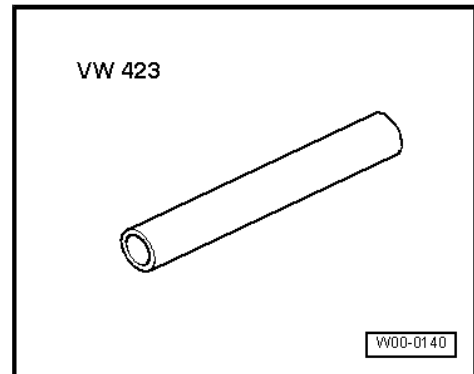

- ◆ Puller hooks -T20143-

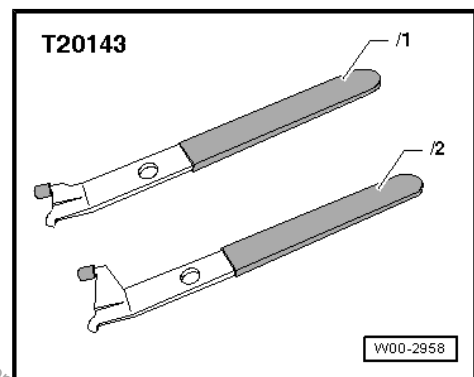

- ◆ Torque wrench -V.A.G 1331-

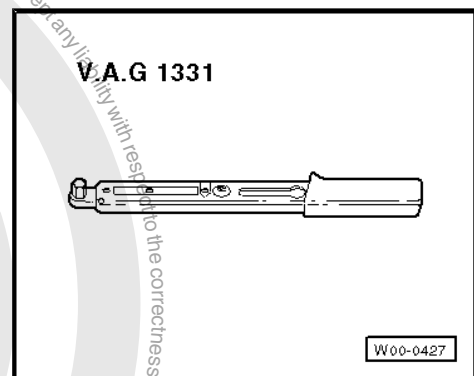

- Remove selector lever cable from gearbox ⇒ [page 61](#) .
- Unbolt lever -A- and carefully pry off selector shaft.

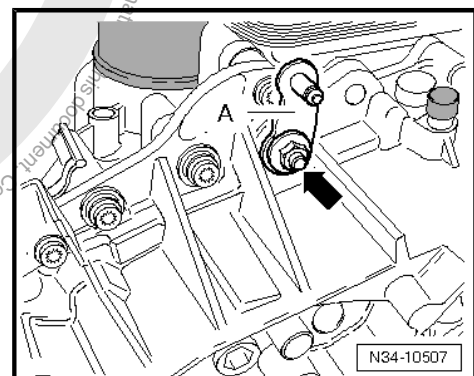



- Pry seal out -in direction of arrow-.

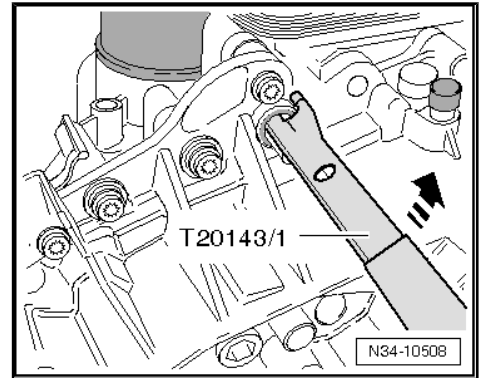

- Fill space between sealing lip and dust lip -arrow- with sealing grease -G 052 128 A1- .
- Lightly oil outer circumference of oil seal.

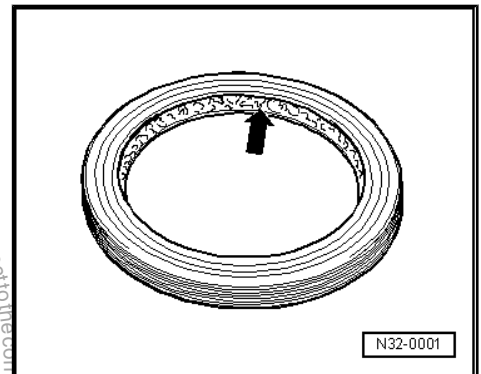

- Drive in new seal to stop. Do not cant oil seal in the process.
- Closed side of oil seal -arrow- points towards tube -VW 423- .

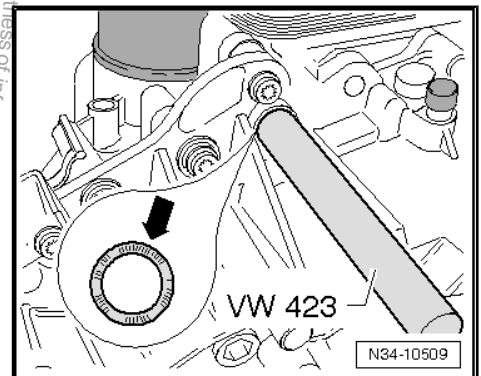

- Apply lever and tighten nut to 20 Nm.

**Selector shaft lever fits on splines in only one position.**

- Install and adjust selector lever cable on gearbox  
⇒ [page 61](#) .

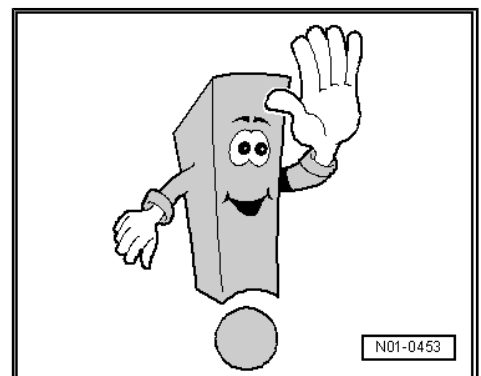



## 5 Selector mechanism



### WARNING

*Before working on vehicle with engine running, move selector lever into position „P“ and apply handbrake.*

### 5.1 Overview - selector mechanism in vehicles up to 02.2009

#### 1 - Selector cover with knob

- Do not remove knob without reason. For emergency release, only the cover needs to be unclipped ⇒ [page 72](#) .
- Before removing knob, pull lock button out past its pressure point. Secure lock button with a cable tie or appropriate wire against being pressed in. This will prevent lock button from being accidentally pressed into the knob.

#### 2 - Selector lever and selector mechanism

- With selector lever lock solenoid -N110-
- Emergency release ⇒ [page 72](#)
- Brief instructions for removing and installing:
  - Remove centre console.
  - Remove Bowden cable from gearbox ⇒ [page 61](#) .
  - If necessary, disconnect or remove parts of exhaust system ⇒ Rep. gr. 26 ; Removing and installing parts of exhaust system .

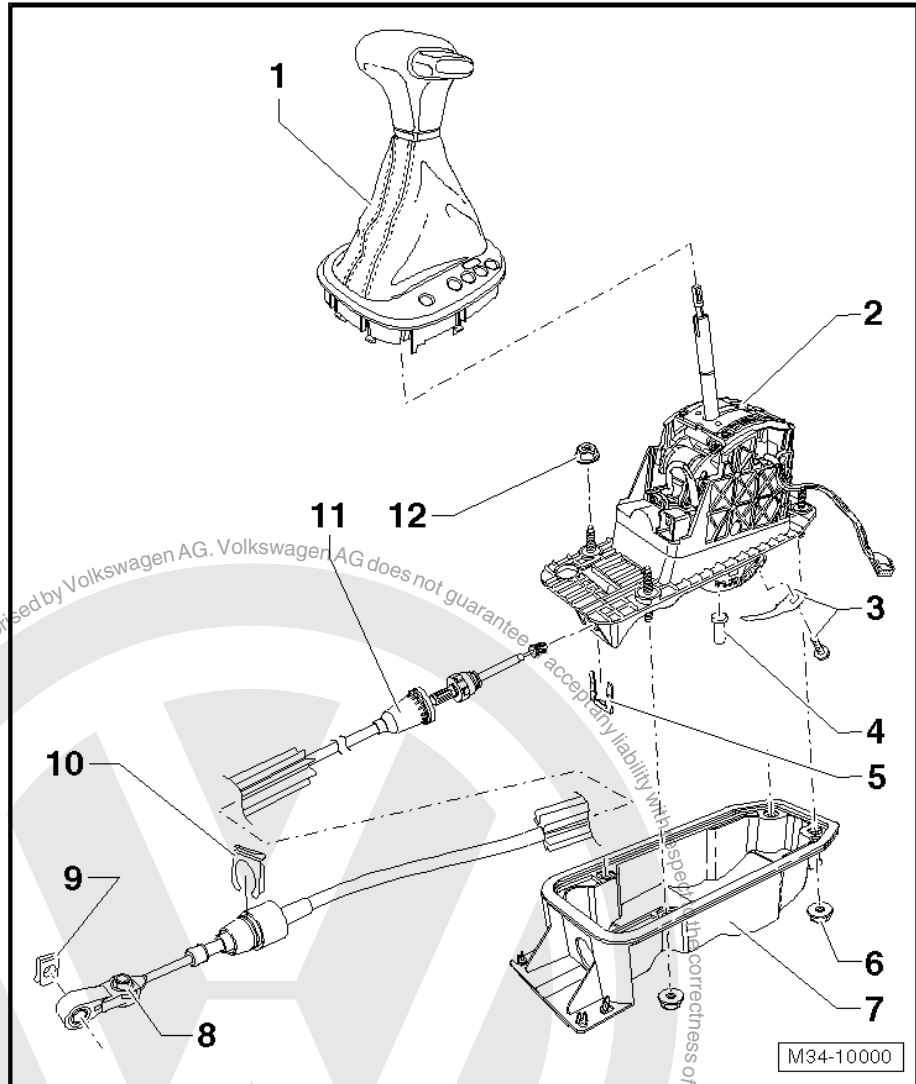

- Remove heat shield beneath selector mechanism.
- Adjust selector lever cable after installing ⇒ [page 70](#) .

#### 3 - Bolt with spring

- 3 Nm

#### 4 - Pin

- Removing ⇒ [page 61](#)
- Do not grease

#### 5 - Locking plate

- Always renew after removing



#### 6 - Nut

- 9 Nm
- Qty. 4

#### 7 - Selector housing

- With seal

#### 8 - Adjuster screw

- 13 Nm

#### 9 - Securing clip

- Always renew after removing

#### 10 - Securing clip

- Always renew after removing

#### 11 - Selector lever cable

- Bowden cable must not be greased
- Removing and installing ⇒ [page 61](#)
- Checking ⇒ [page 70](#)
- Adjusting ⇒ [page 70](#)

#### 12 - Hexagon flange nut

- 8 Nm
- Qty. 4

## 5.2 Removing and installing selector lever cable - vehicles up to 02.2009



### Note

*Following installation, Bowden cable must be checked for ease of movement and be adjusted.*

### Removing

- Move selector lever to position „S“ position.

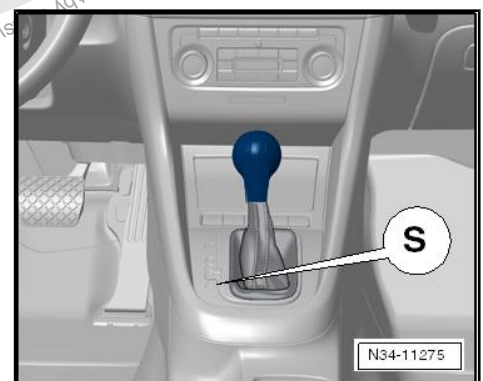



Loosen adjustment screw -arrow-.



**Note**

*Use pliers to remove the securing clip -B- on the cable support bracket. Do not use a sharp-edged lever. Otherwise, the rubber grommet on the cable could be damaged.*

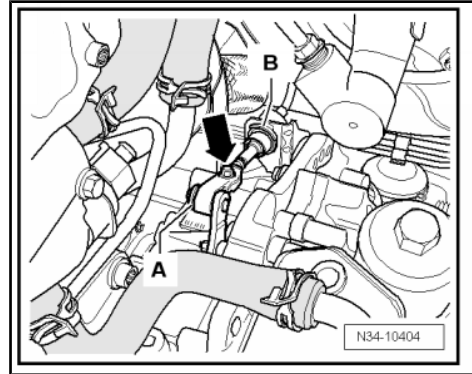

- Remove securing clips -A- and -B-. Securing clips must be renewed when Bowden cable is later adjusted.
- Raise vehicle.
- To remove Bowden cable and/or selector mechanism, heat shield under selector mechanism and, if necessary, parts of exhaust system must now be removed → Rep. gr. 26 ; Removing and installing parts of exhaust system .

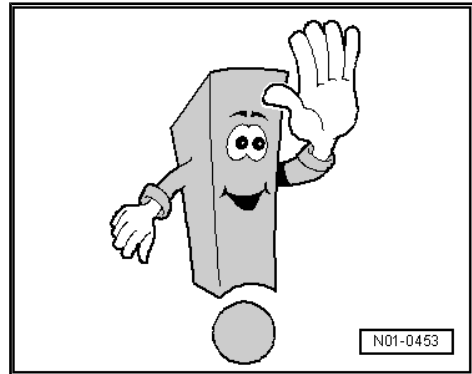

- Remove -selector housing- beneath selector lever.

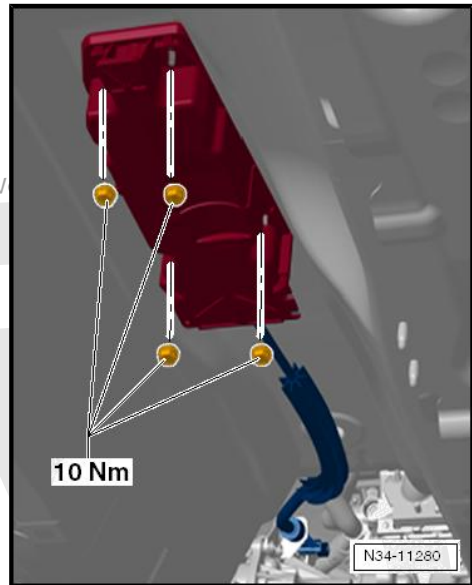

- Remove locking plate of cable support bracket. Always renew locking plate.

part or in whole, is not permitted unless authorised by Volkswagen AG. V  
Protected by copyright. Copying for private or commercial purposes

correctness of information in this document. Copyright by Volkswagen AG.

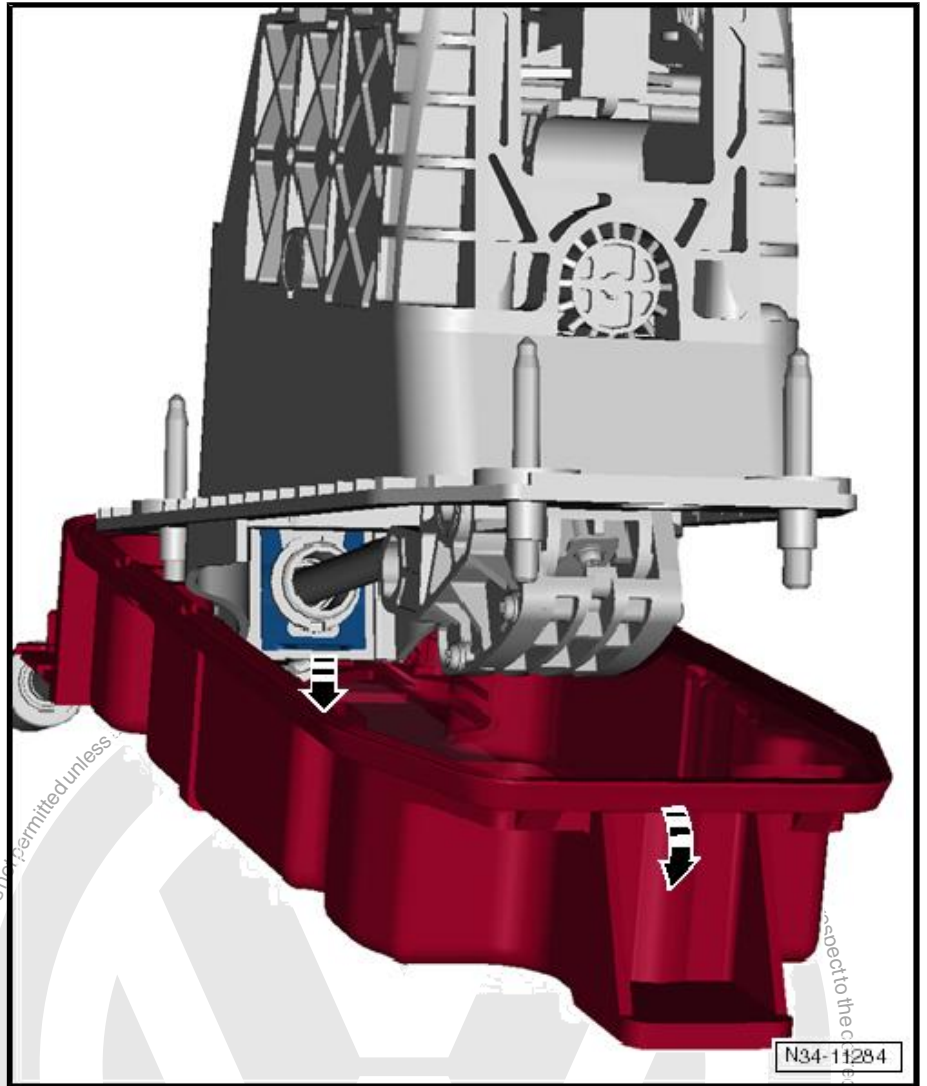

-Selector housing- is pushed forwards slightly on cable.

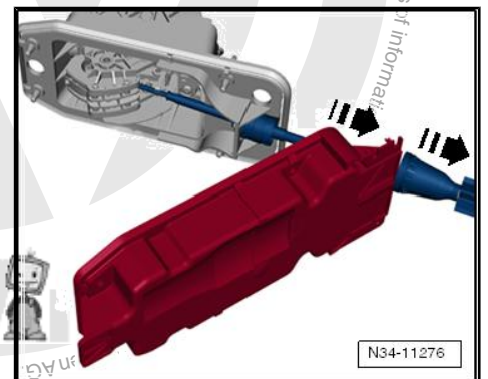



To remove cable, securing tab must be pushed forwards -1-.

- At same time, push -pin- up with a screwdriver -2-.



- Please insert -screwdriver- from underneath whilst pushing securing tab forwards.

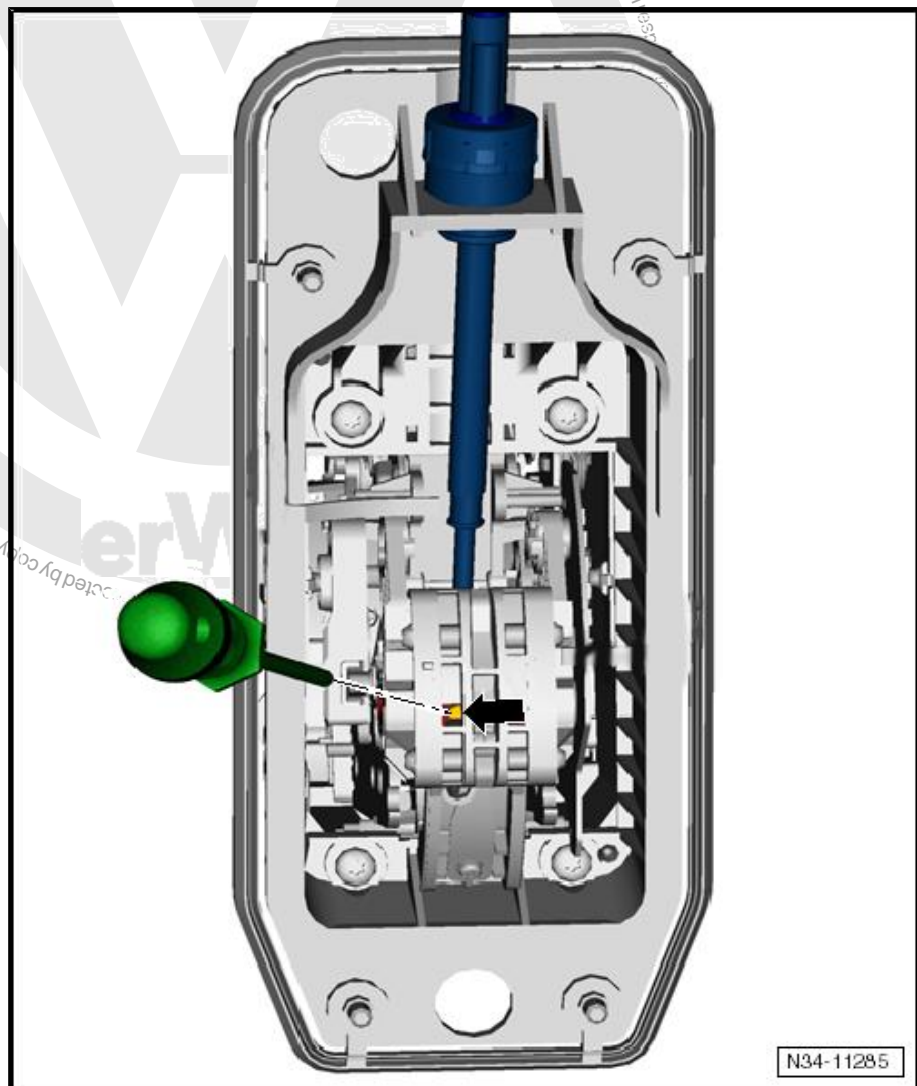



**Clarification:**

- ◆ -1- Push tab forwards
- ◆ -2- Push pin up

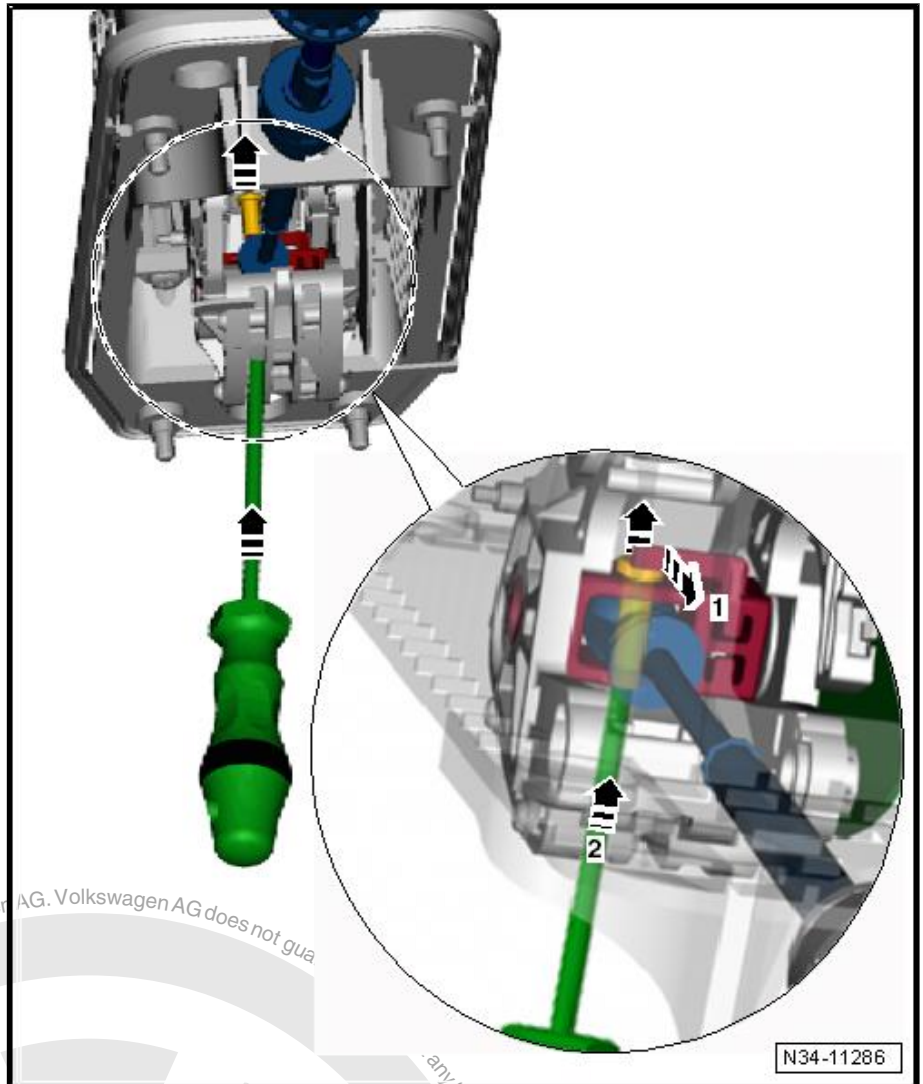

- Remove selector lever cable.
- Remove selector housing from cable.

**Installing**

Do not grease cable.

- Route selector lever cable without tension. Also insert in cable support bracket on gearbox. Do not secure with securing clips yet. Do not clip in ball head.

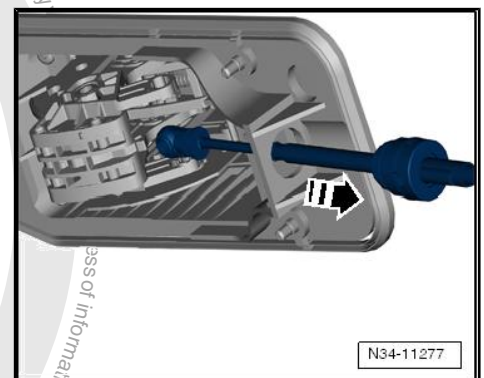



- Ensure that selector lever cable is properly routed during installation.

If the sheet metal is bent downwards, it may cause noises. The cable will »vibrate« against the sheet metal.

- Observe sheet metal. Press it back up in the tunnel during installation -direction of arrow-.

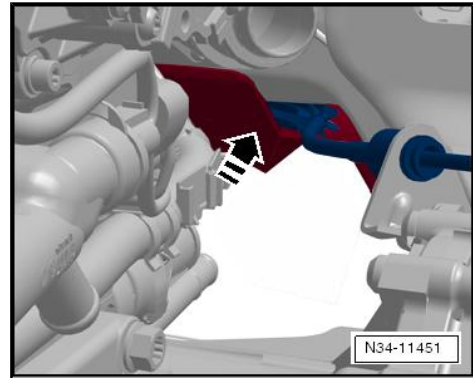

- Put selector housing onto cable.

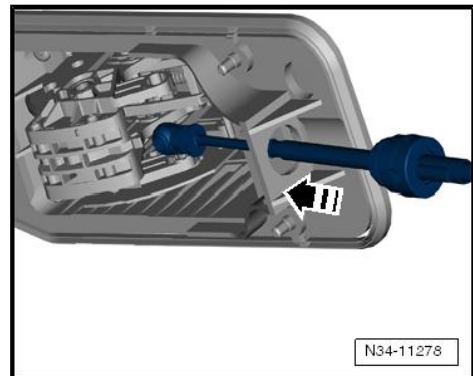

- Insert selector lever cable into selector mechanism.
- Insert cable into bearing and insert pin from above, downwards through eye.

When you have checked freedom of movement of cable  
⇒ [page 70](#) , insert locking plate.

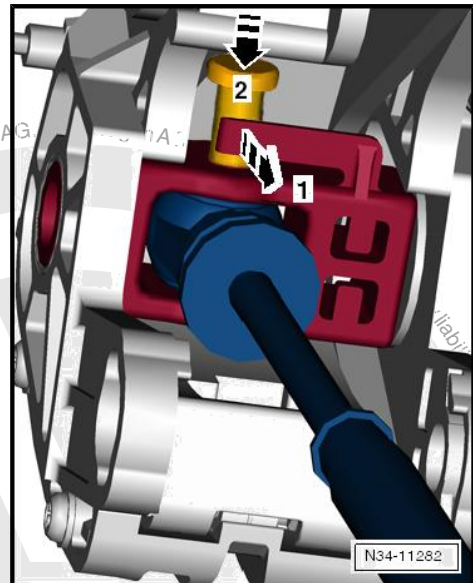

- Attach cable with new locking plate on cable support bracket of selector mechanism.





### 5.3 Overview of selector mechanism - vehicles from 03.2009 onwards

#### 1 - Selector cover with knob

- Do not remove knob without reason. For emergency release, only the cover needs to be unclipped ⇒ [page 72](#) .
- Before removal of knob, pull lock button out past its pressure point. Secure locking button with a cable tie or appropriate wire against being pressed in. This will prevent lock button from being accidentally pressed into the knob.
- Removing and installing selector lever knob ⇒ [page 73](#)

#### 2 - Selector mechanism with selector lever and selector lever cable

- With selector lever lock solenoid -N110-
- Cable must not be greased
- Removing and installing ⇒ [page 69](#)
- Checking ⇒ [page 70](#)
- Adjusting ⇒ [page 70](#)

#### 3 - Bolt

- 8 Nm

#### 4 - Hexagon flange nut

- 8 Nm
- Qty. 4

#### 5 - Selector housing

#### 6 - Adjuster screw

- 13 Nm

#### 7 - Securing clip

- Always renew after removing

#### 8 - Securing clip

- Always renew after removing

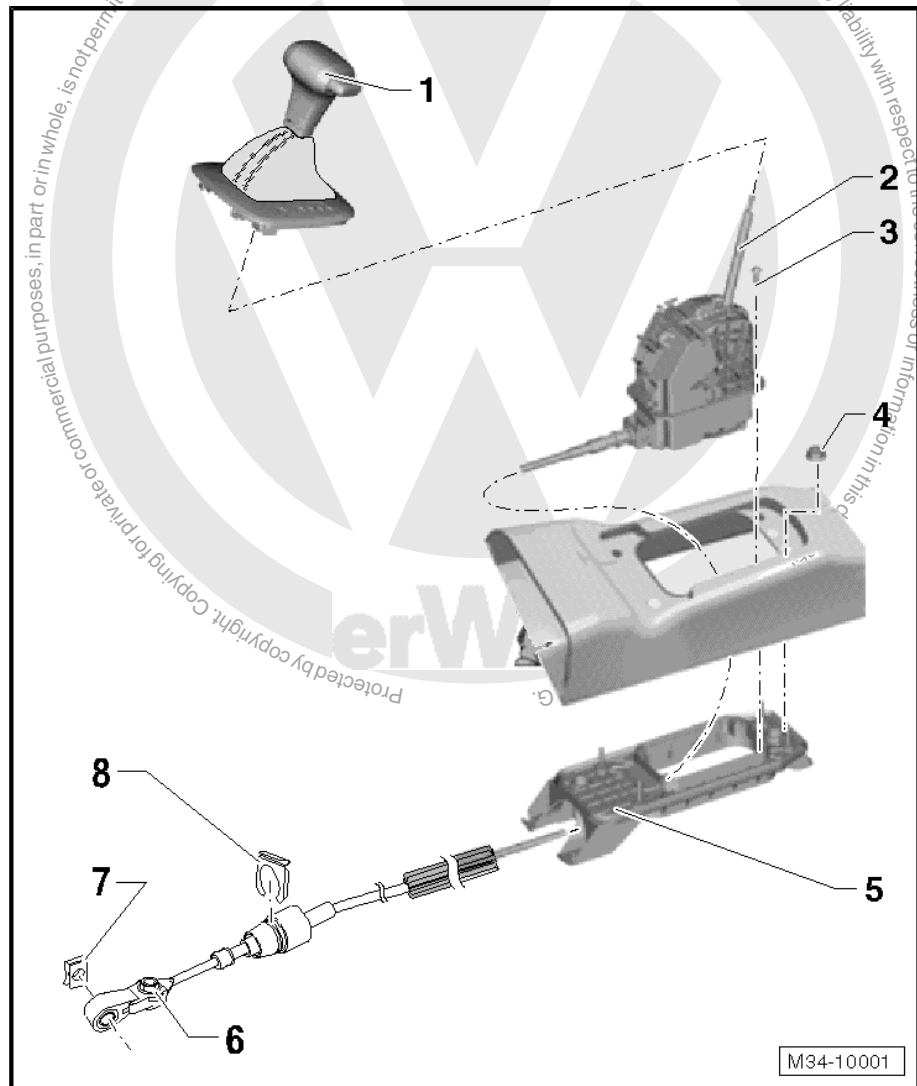



## 5.4 Removing and installing selector mechanism with selector lever and selector lever cable - vehicles from 03.2009 onwards

Perform the following steps:

Selector mechanism and selector lever cable are not allowed to be separated from one another. Both are removed together. In the engine compartment, it may be necessary to provide installation space. Often, it is necessary to remove air filter.

In the interior, it may be necessary to remove centre console.

### Note

Following installation, Bowden cable must be checked for ease of movement and be adjusted.

- Move selector lever to position „P“ position.
- Remove selector lever handle => [page 73](#) .
- Remove centre console => Rep. gr. 68 .

- Remove 4 bolts.

**Torque setting: 8 Nm**

- Raise vehicle.
- Remove heat shield beneath selector mechanism. This makes subsequent removal of selector mechanism easier.

To do so, remove parts of exhaust system if necessary => Rep. gr. 26 ; Removing and installing parts of exhaust system .

Loosen adjustment screw -arrow-.

### Note

Use pliers to remove the securing clip -B- on the cable support bracket. Do not use a sharp-edged lever. Otherwise, the rubber grommet on the cable could be damaged.

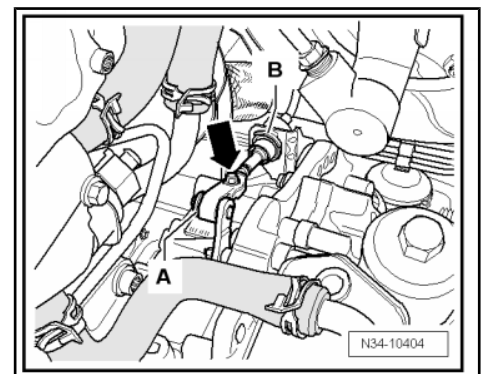
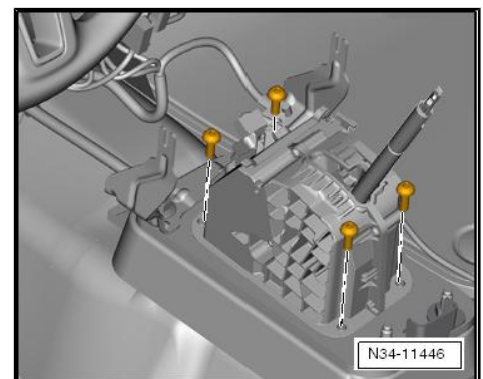
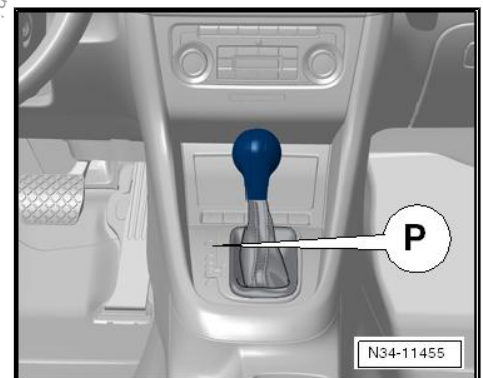
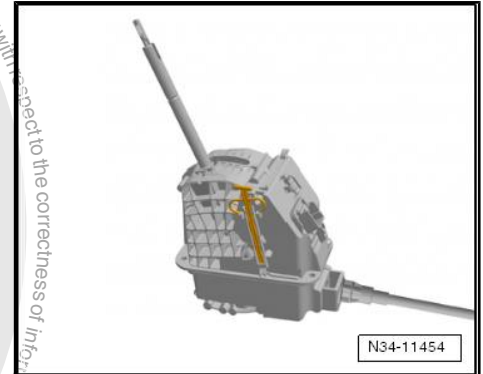



- Remove securing clips -A- and -B-. Securing clips must be renewed when Bowden cable is adjusted.

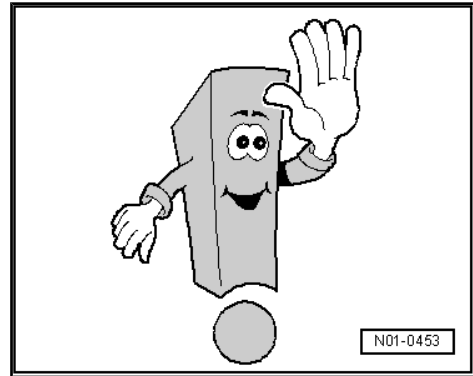

- Remove selector mechanism.

Install in reverse order of removal.

- Before you put on ball head: check cable ⇒ [page 70](#) .
- Install all parts of exhaust system which were removed ⇒ Rep. gr. 26 ; Removing and installing parts of exhaust system .
- Install heat shield ⇒ Rep. gr. 66 .
- Adjust selector lever cable after installing ⇒ [page 70](#) .

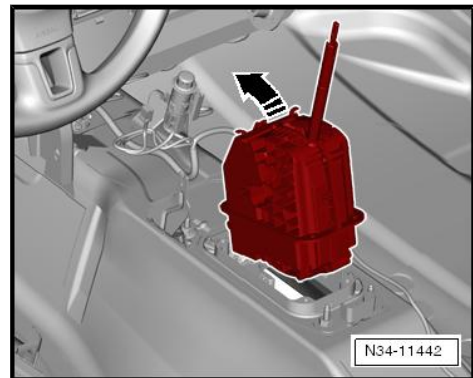

## 5.5 Checking selector lever cable

### Brief description

Selector lever cable must be removed from gearbox so that its ease of movement can be checked. Put removed end down so it does not rub against anything.

Then the selector lever must be moved and after that, the Bowden cable must be reattached to the gearbox.

Then the selector lever cable must be adjusted ⇒ [page 70](#) .

Do not grease connections of cable!

### Checking

- Move selector lever to position »P« position.
- Remove cable from lever on gearbox.
- Move selector lever repeatedly from »P« to »S« and back to »P«.
- Selector lever must move easily.
- Install cable using new securing clip and »loosened« adjusting screw.
- Adjust cable ⇒ [page 70](#) .

## 5.6 Adjusting selector lever cable

### Special tools and workshop equipment required



- ◆ Torque wrench -V.A.G 1331-

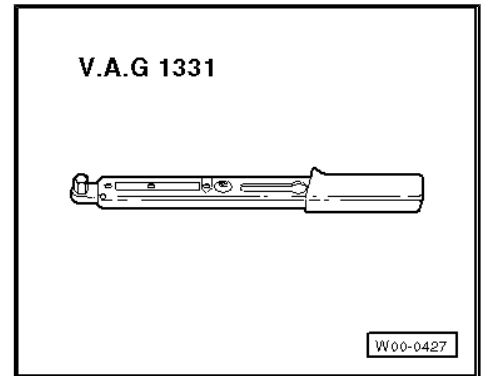

**The selector lever cable must always be adjusted whenever**

- ◆ The selector lever cable has been removed from the gearbox.
- ◆ The engine and/or gearbox has been removed and installed.
- ◆ Parts of the assembly mounting have been removed and installed.
- ◆ The cable itself or the selector mechanism has been removed and installed.
- ◆ The position of the engine and gearbox is shifted, for example to install it free of tension.

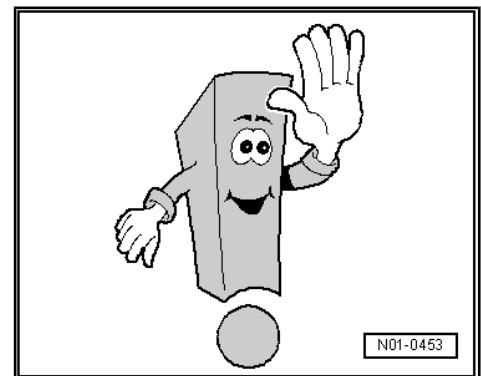

**Adjusting**

- Move selector lever in vehicle to „P“ position.

**Shift lever on gearbox to position „P“.**

Lever on gearbox must be pressed »all the way back«.

If you are not certain:

- Pull lever forwards.
- Push lever »backwards«.

„P“ is in second detent.

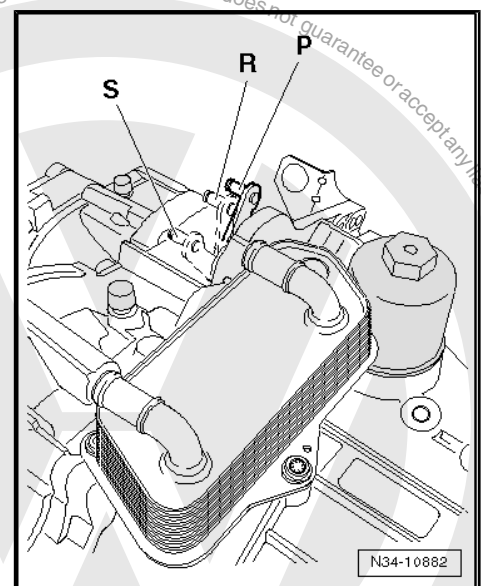

- Install cable with loosened adjusting screw -arrow- and new securing clips -A- and -B-.

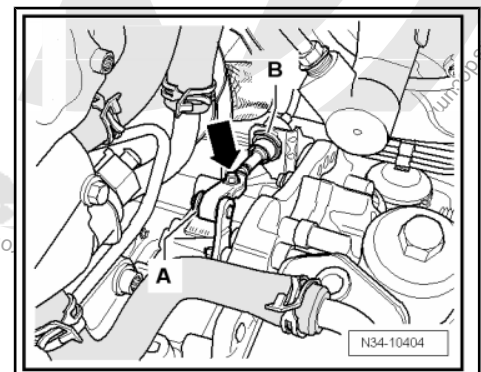



- Push lever on gearbox backwards -arrow-. This also puts gearbox in position „P“.



#### Note

*Raise vehicle, to be sure that the gearbox is in „P“ (parking lock engaged). It should not be possible to turn both front wheels together in the same direction.*

- Gently push knob of selector lever forwards and backwards but under no circumstances must you shift out of „P“.

In this way the → core of the Bowden cable finds its optimal position.

- Tighten adjusting screw -arrow- to 13 Nm.

This completes the adjustment.

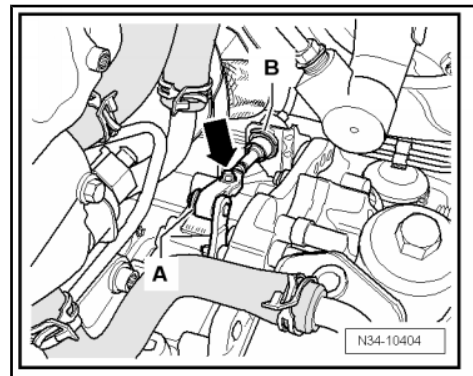
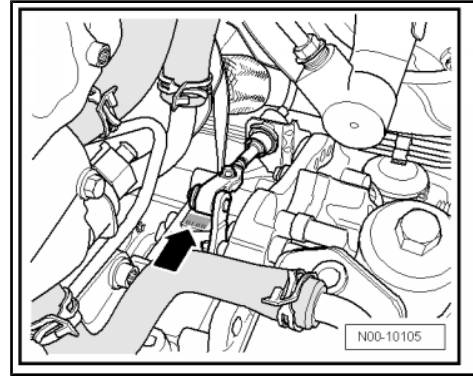

## 5.7 Emergency release of selector lever

**Do not remove knob.**

- Unclip selector cover and hold to side.
- Depress brake pedal or set handbrake.

**Vehicles up to 02.2009**

- Press yellow plastic part -arrow- from right to left.
- Or press on the pin of the solenoid.

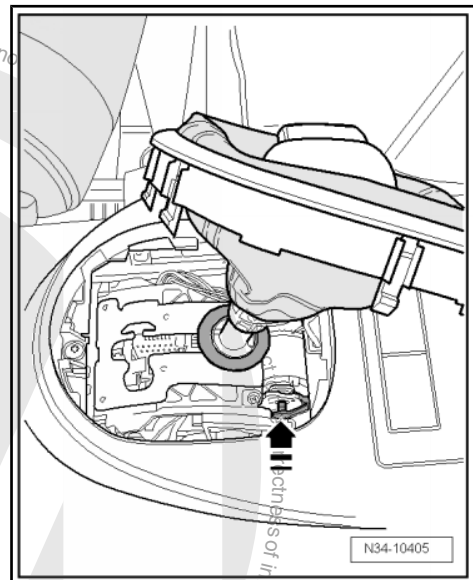



### Vehicles from 03.2009 onwards

- Press yellow plastic wedge -arrow-.

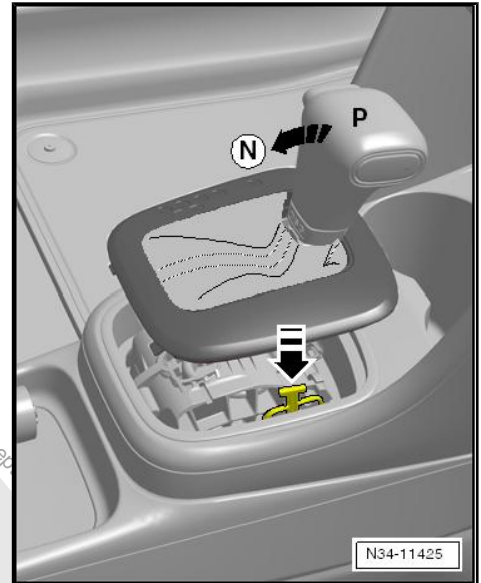

## 5.8 Removing and installing selector lever knob

It is possible with all knobs that lock button is pressed into knob.  
Do not install a knob with the locking button pressed in.

- Before removal, pull lock button out past its pressure point.
- Secure locking button with a cable tie or wire against being pressed in.
- Unclip cover.

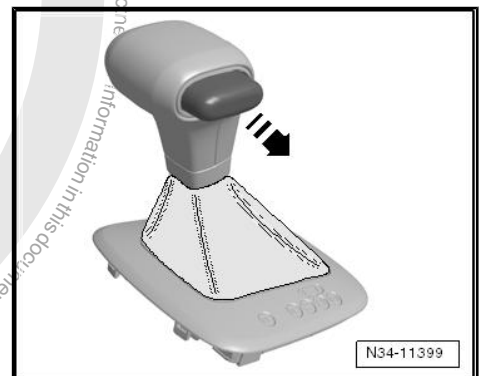

- Push sleeve upwards to release knob.
- Lock the handle again after installing. To do this, press the sleeve under the handle back down.

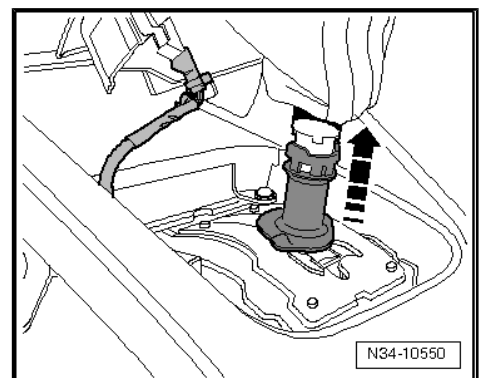



- You only have to remove transport guard from »new« handles. The locking button is already in installation position.
- Pull connector from cover.
- Pull off knob upwards.
- Lock the handle again after installing. Press the sleeve under the handle back down.

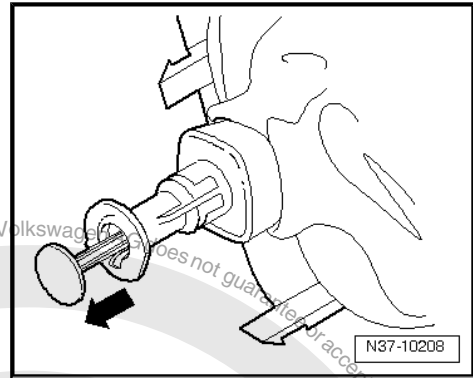

#### In vehicles with lock button at front on knob -arrow-

Lock button -arrow- is not allowed to be pressed in when knob is being fitted and removed.

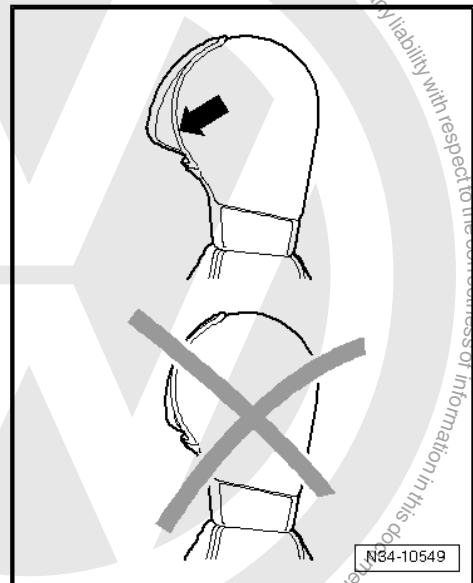

- However, should this happen, unclip knob trim upwards.
- Press small lever for pull rod -arrow- back into groove before installing knob.

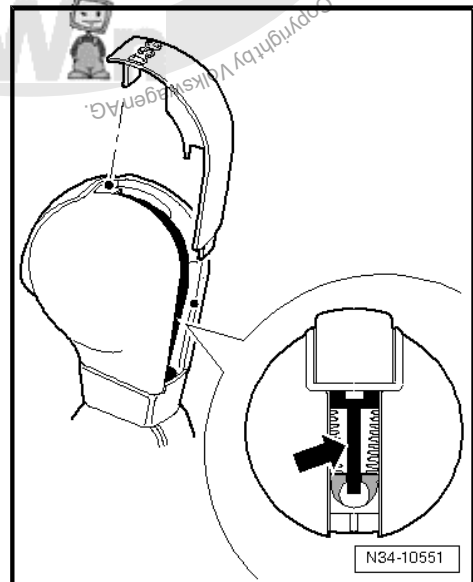

## 5.9 Checking selector mechanism

The starter must not operate in the selector lever positions „R“, „D“ or „S“.

On a right-hand drive vehicle, starter must only operate in selector lever positions „P“ and „N“ when lock button is not pressed.



When selector lever is shifted to position „N“ at speeds above 5 km/h, solenoid for selector lever lock must not engage and block selector lever. Selector lever can be shifted into a driving range.

When travelling at speeds below 5 km/h (almost stationary) and shifting into selector lever position „N“, solenoid for selector lever lock should only engage after about 1 second. Selector lever can not be shifted out of „N“ position until brake pedal is depressed.

#### **Selector lever in „P“ position and ignition switched on**

- Brake pedal not depressed:

Selector lever is locked and cannot be shifted out of „P“ position with the lock button pressed. Solenoid for selector lever lock blocks selector lever.

- Brake pedal is depressed:

Solenoid for selector lever lock releases selector lever. It is possible to shift into a driving gear. Slowly shift selector lever from „P“ through to „S“, checking whether selector lever position in dash panel insert corresponds to selector lever position.

#### **Selector lever in „N“ position and ignition switched on**

- Brake pedal not depressed:

Selector lever is locked and cannot be shifted out of „P“ position with the lock button pressed. Solenoid for selector lever lock blocks selector lever.

- Brake pedal is depressed:

Solenoid for selector lever lock releases selector lever. It is possible to shift into a driving gear.

#### **Selector lever in position „Tiptronic“**

- Shift selector lever into Tiptronic gate.

The illumination of the „D“ symbol in the selector mechanism cover must go out. „+“ and „-“ symbols must light up.

When the selector lever is shifted into the Tiptronic gate, the selector lever position display in the dash panel insert must change from „P R N D S“ to „6 5 4 3 2 1“.

#### **Ignition and light switched on**

The respective symbol in the shift mechanism cover lights up.

#### **Selector lever position display**

Simultaneous illumination of all selector lever position display segments indicates gearbox emergency running mode.



## 6 Removing and installing gearbox

Remove gearbox ⇒ [page 76](#) .

Installing gearbox ⇒ [page 86](#) .

Torque settings ⇒ [page 87](#)

### 6.1 Removing gearbox

#### Brief description

The gearbox is removed downwards separately.

The battery, air filter and starter are removed »from above«.

Coolant hoses are disconnected »from above«. The engine and gearbox must be supported before the left subframe mounting is unbolted.

»From below«:

Remove -subframe- together with -pendulum support-,  
-steering box- and -both suspension links-.

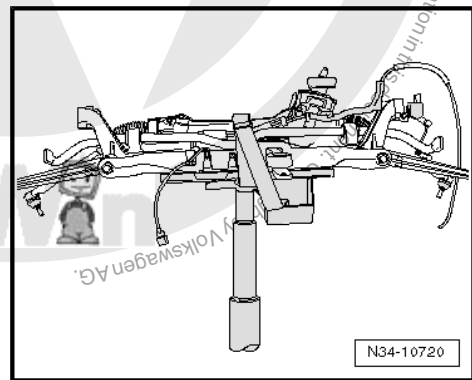

For information on how to remove the -subframe-, refer to ⇒ Rep. gr. 40 . If the job is done correctly, the subframe can be removed and reinstalled without subsequently causing increased tyre wear, which may lead to customer complaints. It is recommended to read this information »before« removing gearbox. Then the position of the -subframe- can be properly fixed and the subframe removed.

In any case, locating pins -T10096- are necessary.

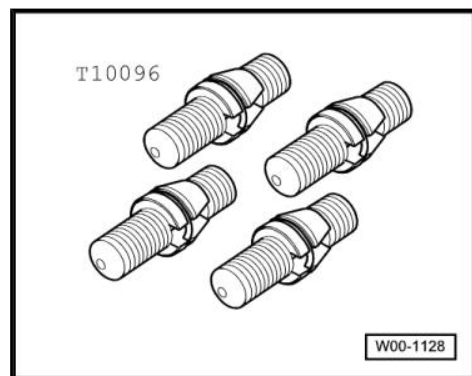

If the position of the -subframe- is not fixed with the pins, the wheels must later be aligned.

**In this case, wheel alignment would be an unnecessary and expensive additional job! Save yourself this work and your customer the expense!**

It requires only a small effort to install the locating pins -T10096- . Their benefit is enormous.

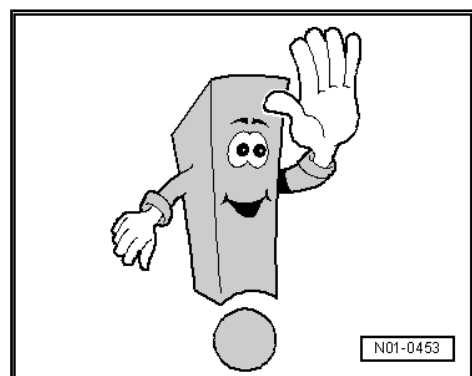



**Special tools and workshop equipment required**

- ◆ Support bracket -10-222A-
- ◆ Adjustment plate -3282/42 A-
- ◆ Adapter -10-222A/8-
- ◆ Adapter -10-222A/3-
- ◆ Gearbox support -3282-
- ◆ Insert tool, 18 mm -T10179-

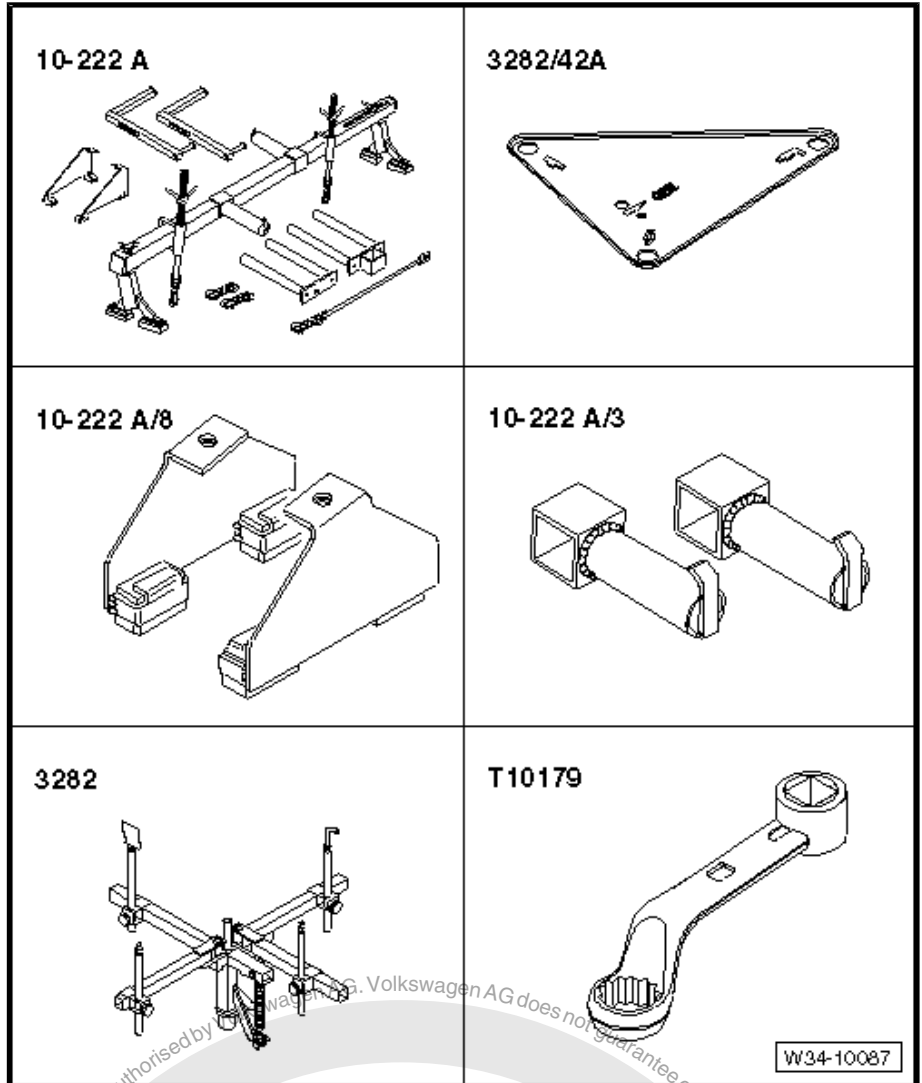

- ◆ 2 hose clamps to 40 mm Ø -3093-

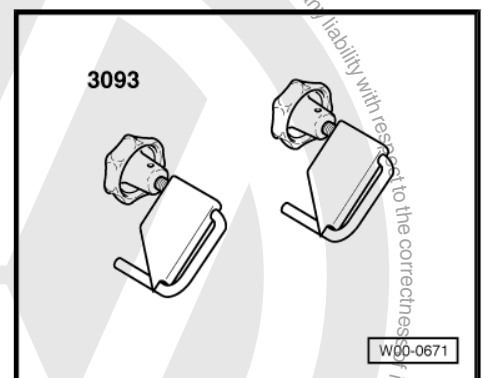

- ◆ Or 2 hose clamps to 25 mm Ø -3094-



◆ Pin -3282/29-

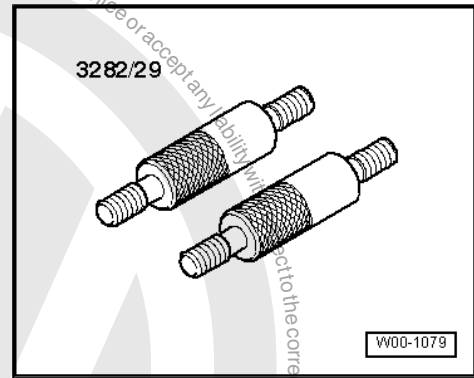

◆ Engine and gearbox jack -V.A.G 1383 A-

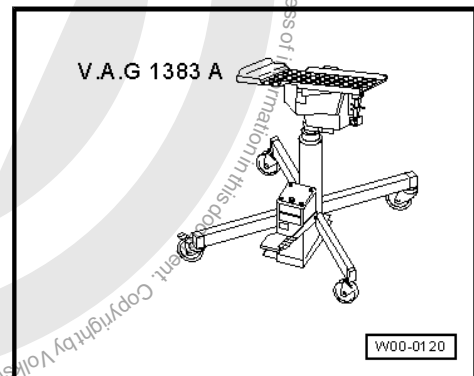

◆ Bracket -T10346-

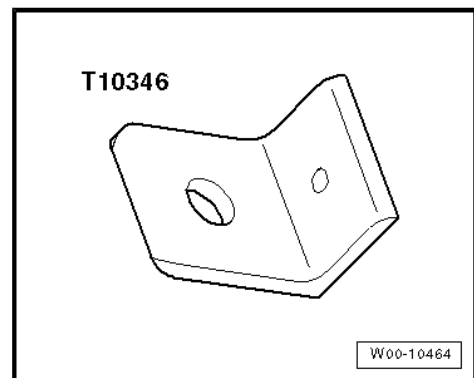

**Perform the following steps:**

- Move selector lever to position »P« position.
- Remove complete air filter housing.
- ◆ Vehicles with petrol engines ⇒ Rep. gr. 24 ; Removing and installing air filter
- ◆ Vehicles with diesel engines ⇒ Rep. gr. 23 ; Removing and installing air filter



- Remove battery and battery tray ⇒ Rep. gr. 27 ; Battery; Removing and installing battery .

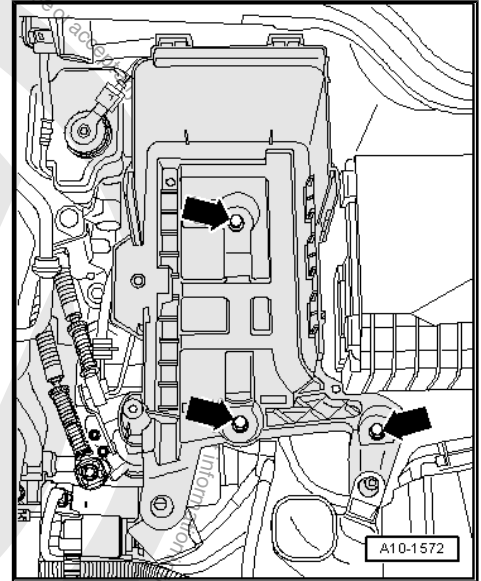

- Remove selector lever cable from gearbox.



**Note**

*Use pliers to remove the securing clip on the cable support bracket. Do not use a sharp-edged lever. Otherwise, the rubber grommet on the cable could be damaged.*

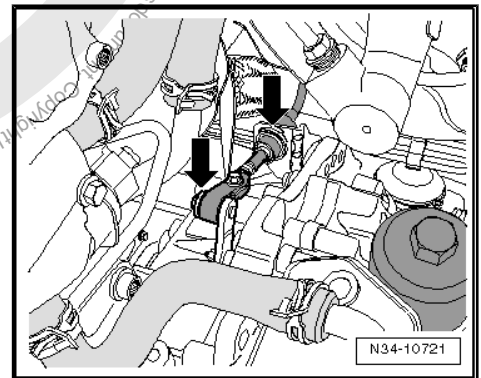

Both securing clips must be renewed when Bowden cable is later adjusted.

Remove cable with great care from cable support bracket on gearbox. Do not bend cable when doing this.

Cable may also be pushed slightly backwards out of cable support bracket and removed later when gearbox is lowered. But then observe Bowden cable when lowering gearbox.

During later installation, do not clip »new« securing clips on until cable has been checked and adjusted ⇒ [page 70](#) .

- Lay lint-free cloths on gearbox oil cooler and gearbox to catch escaping coolant.

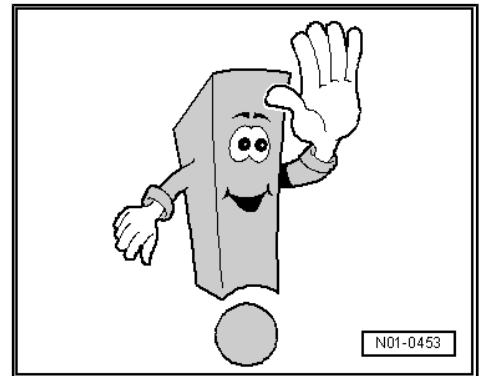

- Clamp off coolant hoses using hose clamps -3093/3094- and remove hoses from gearbox oil cooler.

- Seal off gearbox oil cooler with clean plugs.

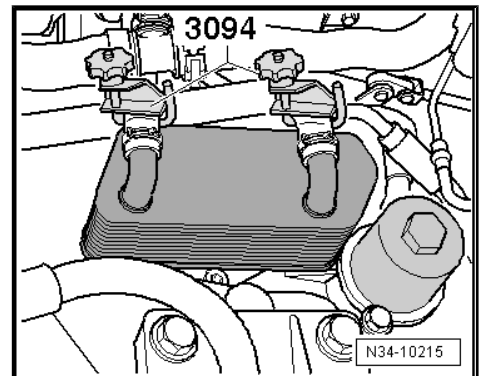



- Remove starter -A- ⇒ Electrical system; Rep. gr. 27 ; Removing and installing starter .

It is advisable to remove the »lower« bolt first.

- Release mechatronic unit connector -1- by turning and pull off connector.
- Unbolt wiring retainer from front of »black« gearbox cover (2 M6 nuts).
- Now remove all upper connecting bolts between engine and gearbox.

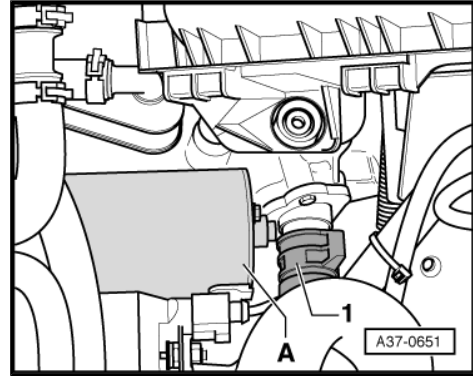

These tools are appropriate for this.

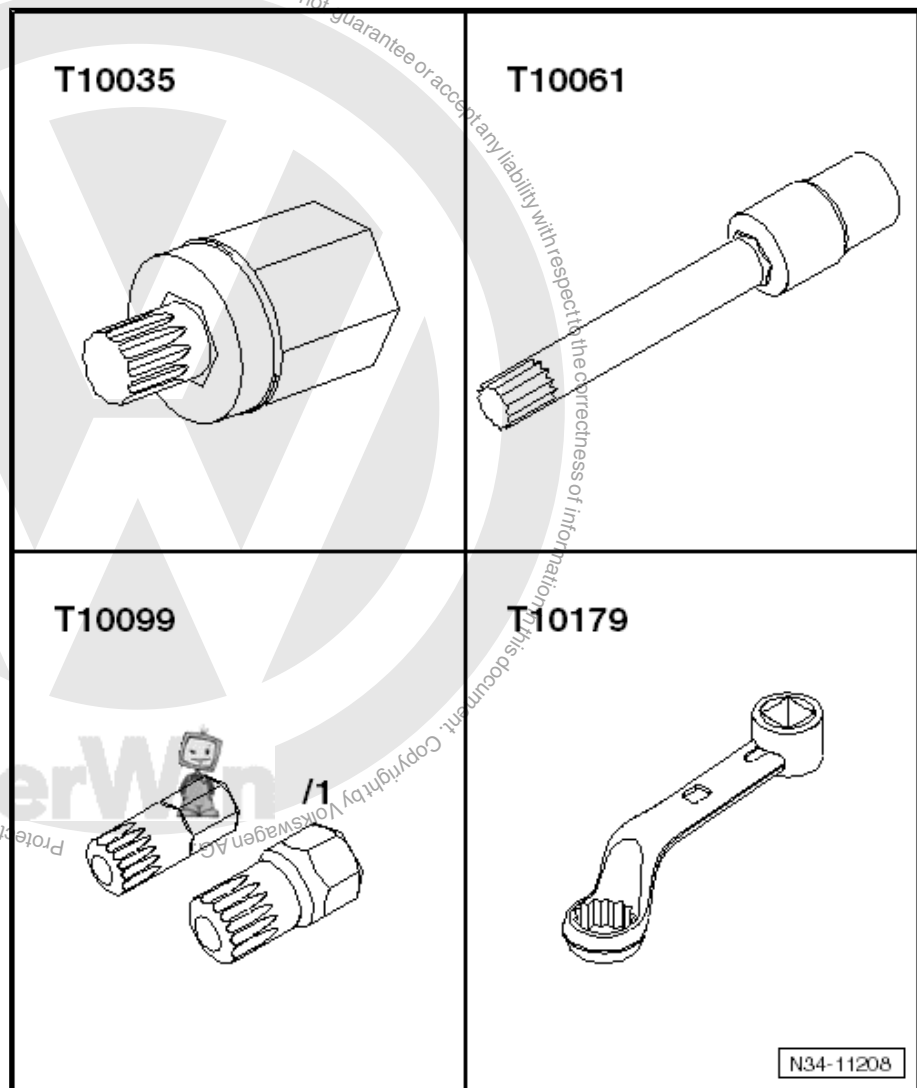

- Remove both filler pieces from upper edge of left and right wings.
- If there are hose and cable connections in area of engine support eye for support bracket -10-222A- , remove these now.

Check the various engines below to see which tools are required to support the engine.



### 1.9 | TDI engine

- Support engine and gearbox, but do not raise.
- ◆ Support bracket -10 - 222 A-
- ◆ Adapter -10 - 222 A /3-
- ◆ Adapter -10 - 222 A /8-

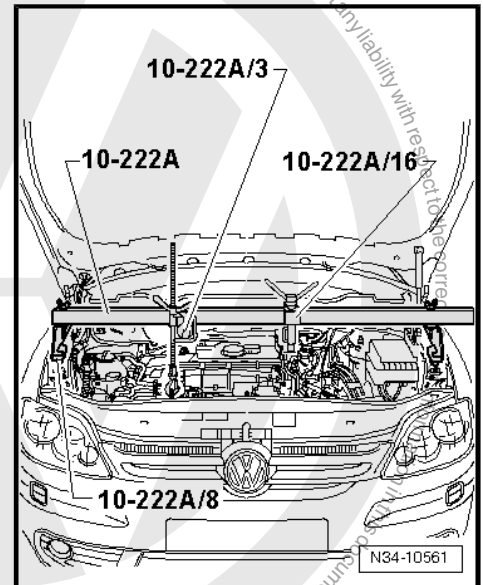

Adapter -10 - 222 A /16-

- ◆ Hook -10 - 222 A /2-
- ◆ Shackle -10 - 222 A /12-

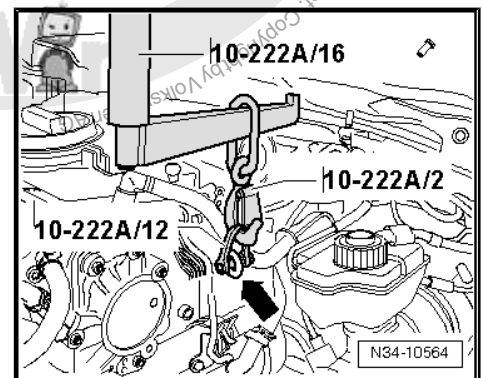

### 2.0 | TDI engine - Jetta 2005 ▶ and Golf Variant 2007 ▶

- Support engine and gearbox, but do not raise.
- ◆ Support bracket -10 - 222 A-
- ◆ Adapter -10 - 222 A /3-
- ◆ Adapter -10 - 222 A /8-
- ◆ Hook -10 - 222 A /10-

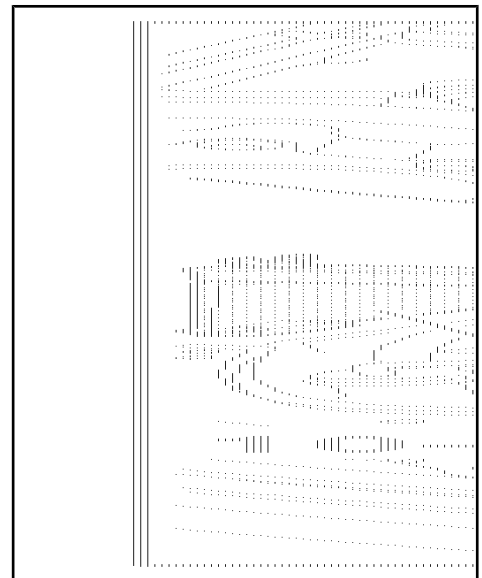

### 2.0 | TDI engine - Golf Variant 2010 ▶

- Support engine and gearbox, but do not raise.

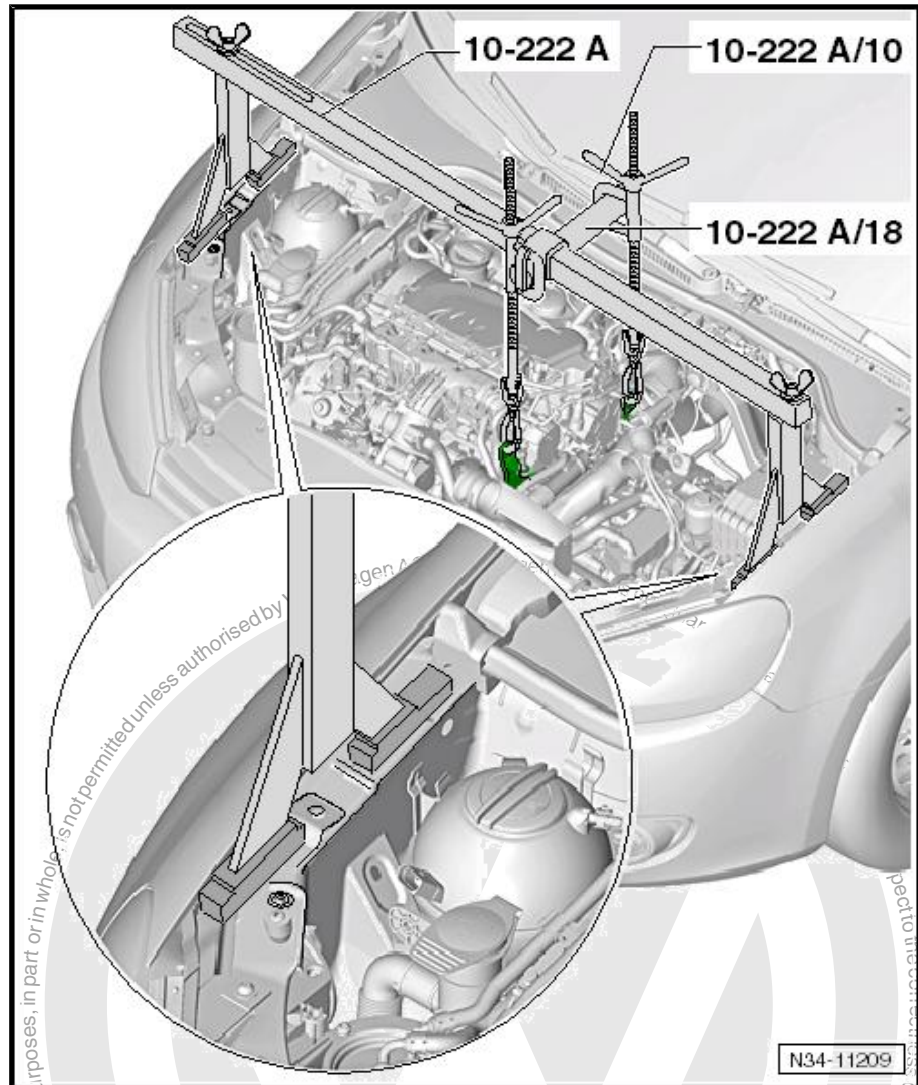

- ◆ Support bracket -10 - 222 A-
- ◆ Hook -10 - 222 A /10-
- ◆ Adapter -10 - 222 A /18-

#### 1.4 I TSI engine

- Support engine and gearbox, but do not raise.
- ◆ Support bracket -10 - 222 A-
- ◆ Adapter -10 - 222 A /8-

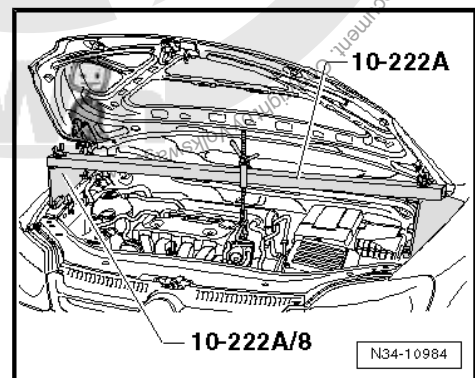



## 2.0 I TFSI engine

- Bolt bracket -T10346- to rear of the 3 mounting holes for battery tray.
- To do this, use a collar bolt M 6 or a securing bolt for battery tray.

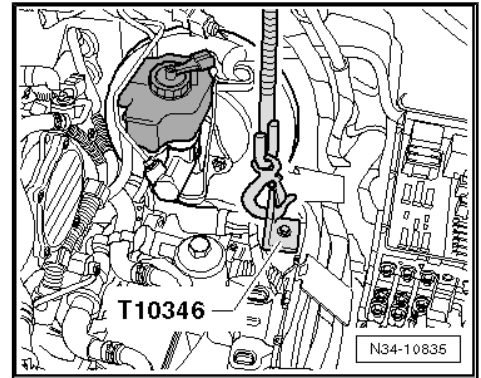

- Support engine and gearbox, but do not raise.
- ◆ Support bracket -10 - 222 A-
- ◆ Adapter -10 - 222 A /3-
- ◆ Adapter -10 - 222 A /8- »smooth side« to engine compartment
- ◆ Bracket -T10346-
- ◆ Use spacer tube -10 - 222 A /17- on the »front« spindle

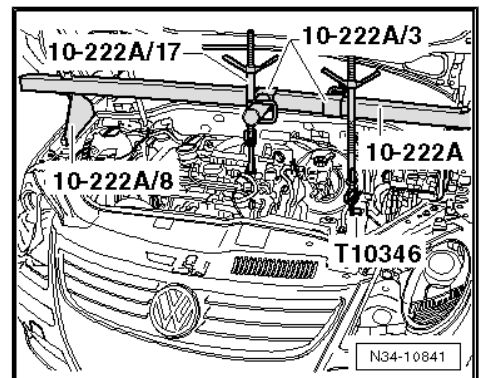

### Continuation for all engines

- Take up weight of engine/gearbox assembly on spindles, do not lift.
- Loosen wheel bolts on front left and front right.
- Raise vehicle. All 4 supports of lifting platform must be at same height.
- Remove front wheels.
- Remove noise insulation => Rep. gr. 50 ; Assembly overview - noise insulation .
- Remove lower part of front left wheel housing liner => Rep. gr. 66 ; Removing and installing wheel housing liner; Front wheel housing liner .
- If present, remove heat shield above right drive shaft. Tightening torque: => Rep. gr. 40 ; Repairing drive shafts .

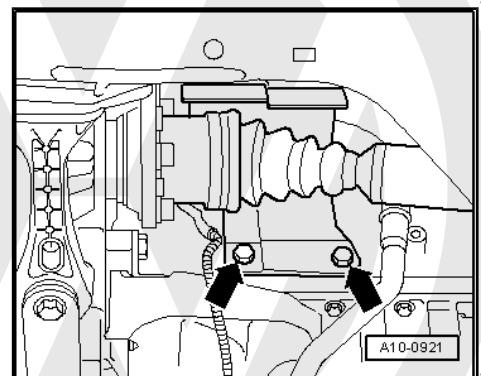

Protected by copyright. Copying for private or commercial purposes, in part or in whole, is not permitted unless authorised by Volkswagen AG. Volkswagen AG does not guarantee or accept any liability with respect to the correctness of information in this document. Copyright by Volkswagen AG.



- Separate exhaust system at clamp and remove exhaust system bracket from subframe -arrows- ⇒ Engine ⇒ Rep. gr. 26 .
- Tie up front exhaust pipe.



**Note**

*The flexible joint of the front exhaust pipe must not be bent more than 10° – danger of damage.*

- Unbolt ⇒ pendulum support from gearbox.
- Secure subframe before removal ⇒ Running gear ⇒ Rep. gr. 40 .



**Note**

*If -subframe- is not located, it will be necessary to perform wheel alignment later.*

- Remove subframe with steering box ⇒ Rep. gr. 40 ; Subframe, anti-roll bar, suspension links; Removing and installing subframe with steering box .
- Unbolt drive shafts from gearbox.
- Raise right drive shaft as high as possible and secure.
- Put left drive shaft to rear and secure (do not damage surface protection when doing this).
- A small cover plate may be located above the right drive shaft flange on the intermediate plate for engine and gearbox. Remove this cover plate -A-.

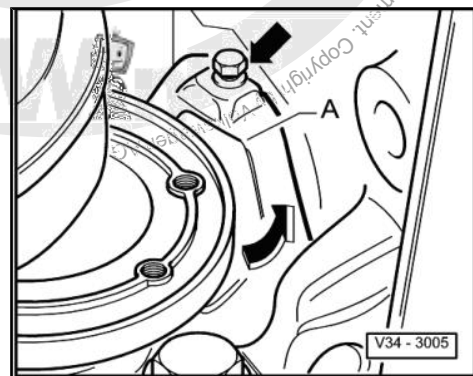
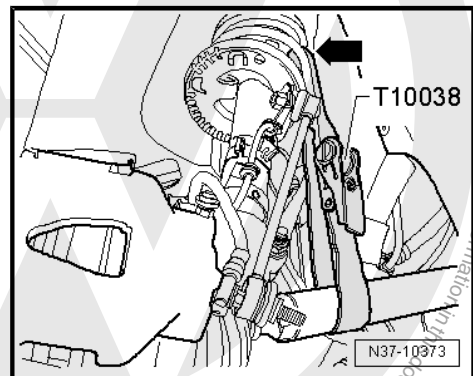
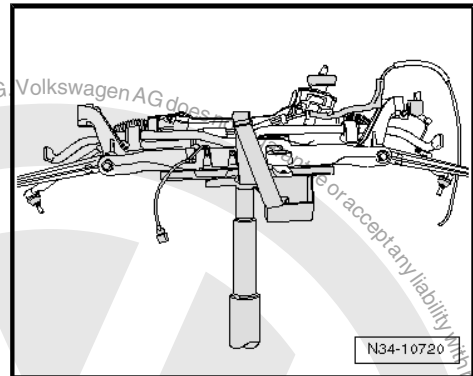
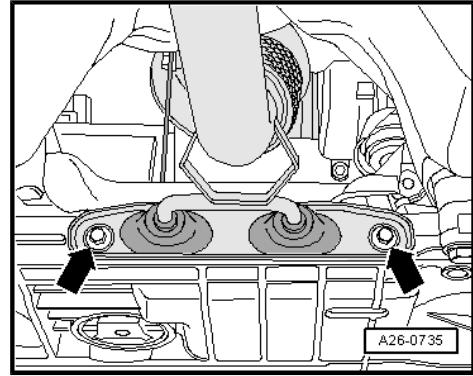



- Remove all bolts -1- and -2- for bracket -A-.
- Then lower engine and gearbox slightly using spindles of support bracket -10 - 222 A- so that bracket can be removed.

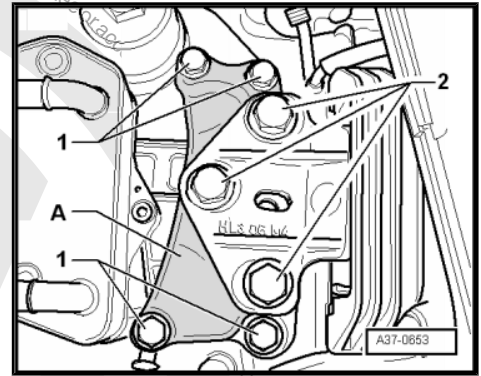

- Remove bracket -arrow-.

To remove gearbox 02E, set up gearbox support -3282- with adjustment plate -3282/42 A- and put onto engine and gearbox support -V.A.G 1383 A- .

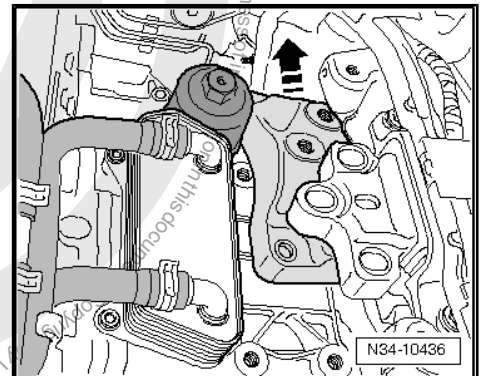

- Align arms of gearbox support according to holes in adjustment plate -3282/42 A- .
- Screw in support elements as illustrated on adjustment plate -3282/42 A- .
- Position engine and gearbox jack -V.A.G 1383 A- under vehicle.
- The arrow on adjustment plate -3282/42 A- points in direction of travel.
- Align gearbox support -3282- parallel to gearbox.
- Screw pin -3282/29- into gearbox.
- Secure both other support elements on gearbox as shown in illustration.

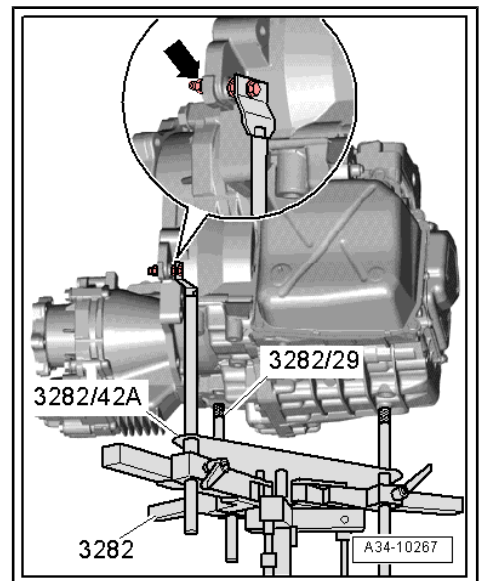

**i Note**

- ◆ *Rather than as shown in illustration on adjustment plate , front support element is bolted onto gearbox as shown -arrow-.*
- ◆ *Illustration shows dual clutch gearbox 02E „four-wheel drive“. Support elements are identical on „front-wheel drive“.*

- Raise gearbox and engine support -V.A.G 1383 A- from below to support gearbox.

The gearbox is separated from the engine in this position.

- Remove remaining engine/gearbox connecting bolts.
- Press gearbox off engine, »observing selector lever cable« and lower gearbox.

Transporting gearbox and securing to assembly stand  
⇒ [page 89](#) .

Installing gearbox ⇒ [page 86](#) .



## 6.2 Installing gearbox

Install in reverse order of removal. Nevertheless, important steps are listed here:

- Check needle bearing -arrow- in crankshaft. If it is damaged or tarnished blue, it must be renewed ⇒ Rep. gr. 13 ; Crankshaft, pulling needle bearing from crankshaft and driving in .
- If it is not damaged, grease lightly with high-temperature grease -G052133A2- .
- End of gearbox shaft (but not splines) also must be lightly greased.
- Check for proper seating of both dowel sleeves between engine and gearbox.
- Check for proper seating of intermediate plate.
- Guide selector lever cable as soon as possible into its cable support bracket.

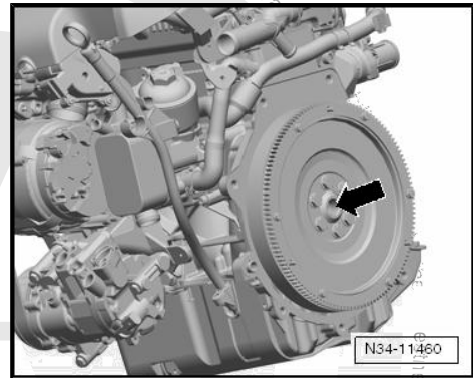

**Check Bowden cable as soon as gearbox is raised. Be sure to insert it in cable support bracket »early«.**

Bowden cable must not be greased.

**It must be possible to guide the engine and gearbox together by hand until the engine flange and gearbox flange make contact all around.**

If not, »something has gone wrong«!

- Readjust gearbox support until engine and gearbox are »aligned with each other«.
- Turn crankshaft slightly if necessary.
- Securing clips for selector lever cable must be renewed.

Torque settings ⇒ [page 87](#) .

- Always adjust selector lever cable ⇒ [page 70](#) .
- Check coolant level and top up if necessary ⇒ Rep. gr. 19 ; Parts of cooling system; Draining and filling coolant .

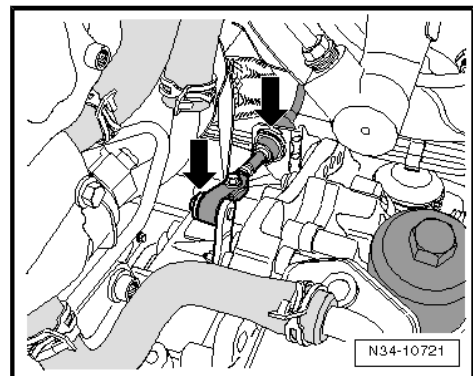



### 6.3 Torque settings

Engine: 1.4 I TSI

M12 - 80 Nm

- If 18 mm insert -T10179- is used: 65 Nm

M10 - 40 Nm

- Arrows point towards dowel sleeves

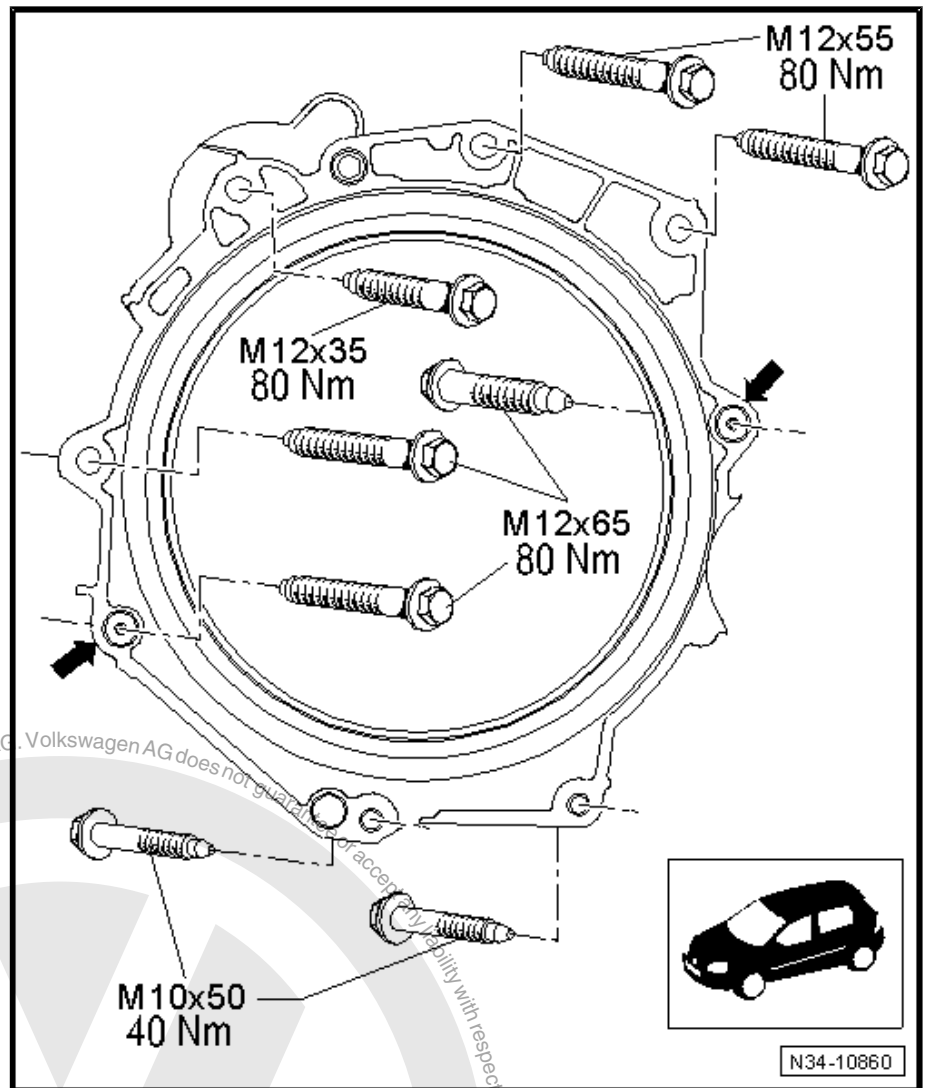

Engines: 1.9 I TDI; 2.0 TDI; 2.0 I TFSI

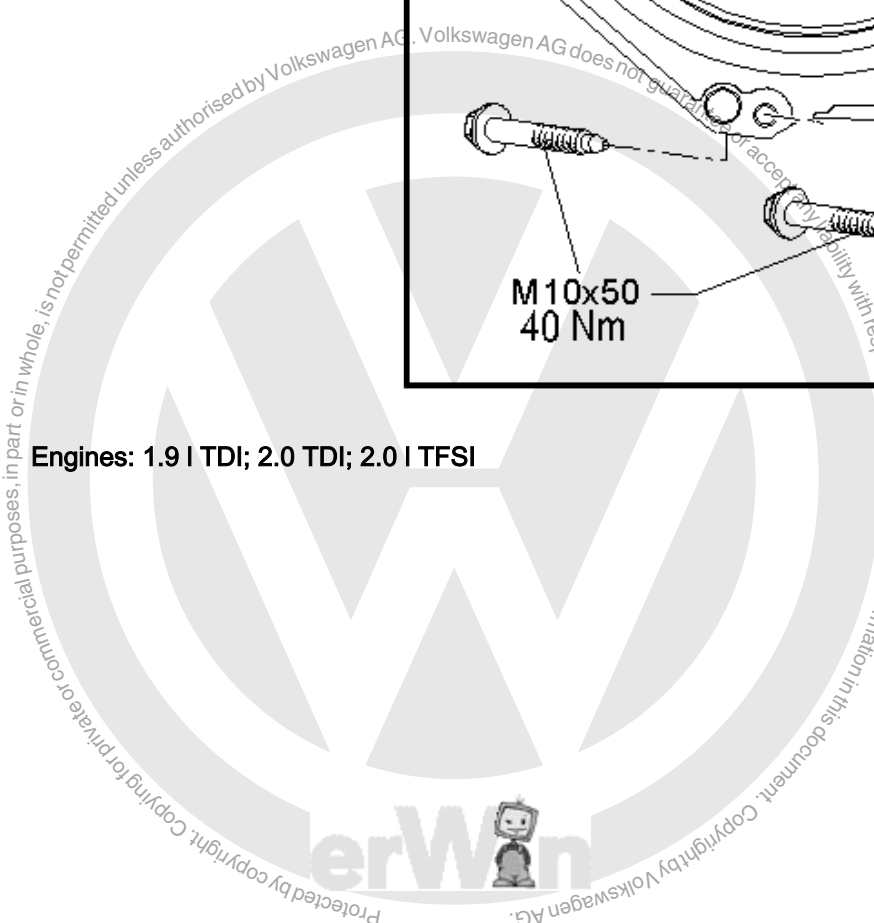



M12 - 80 Nm

- If 18 mm insert -T10179- is used: 65 Nm.

M10 - 40 Nm

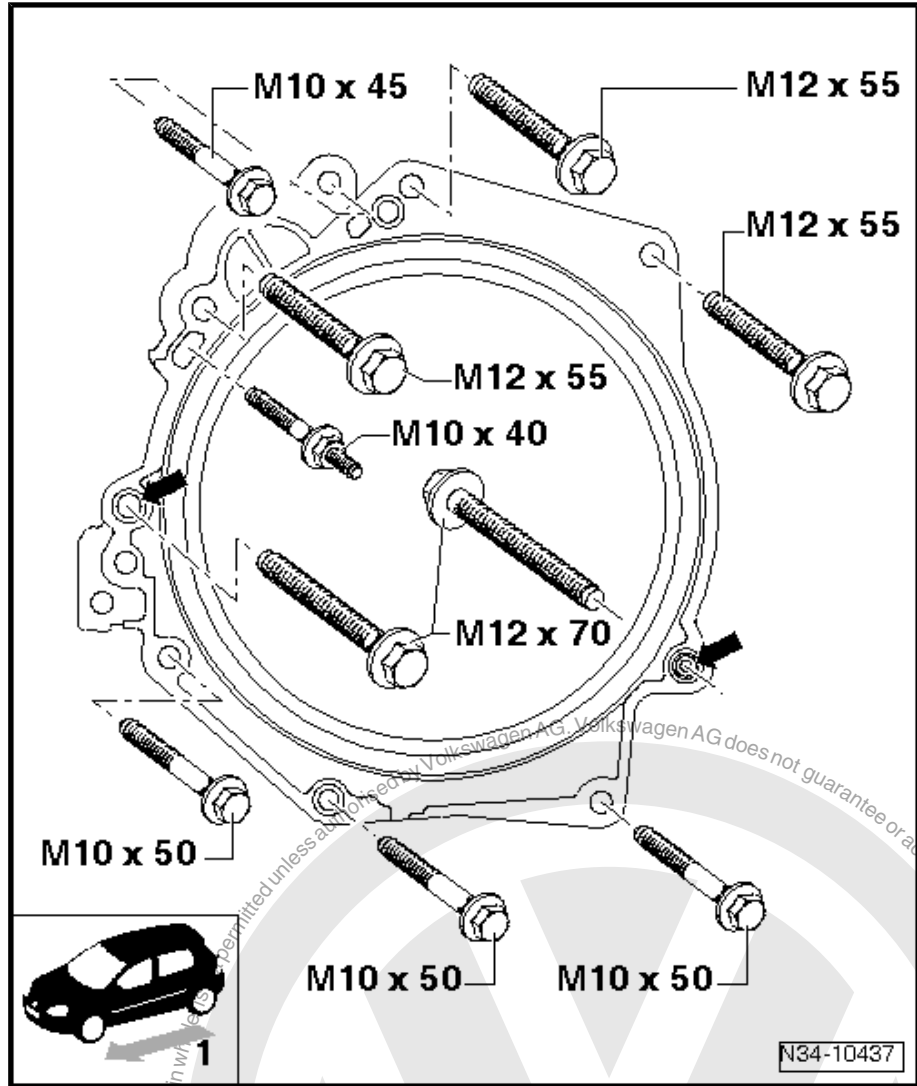

**Continuation for all engines**

- Renew all bolts on left assembly mounting.
- First screw in all bolts by hand.
- First bolt bracket -A- to gearbox with bolts -1- with 40 Nm + 90° further turn.
- Tighten bolts -2- to 60 Nm + 90°.

**Note**

The bracket can be levered into the correct position with a screwdriver as bolts -2- are tightened.

Starter to gearbox ⇒ Rep. gr. 27 ; Removing and installing starter .

Assembly mounting bolts must be renewed.

Install subframe with steering box ⇒ Rep. gr. 40 ; Subframe, anti-roll bar, suspension links; Removing and installing subframe with steering box .

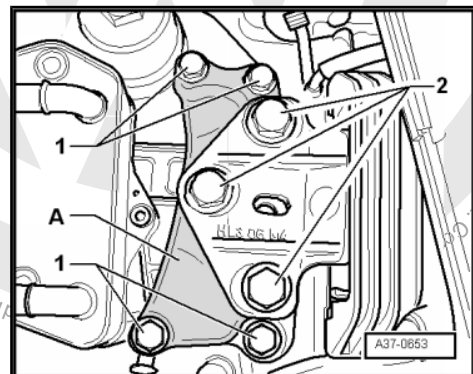



## 7 Transporting gearbox and securing to assembly stand

Always secure heavy parts for transport.

Keep in mind that there is oil in the gearbox. Do not turn gearbox with breather downwards during transport or while on repair stand. Oil will run out.

### Transporting gearbox

- Use appropriate lifting tools, for example part of lifting tackle -2024 A- and shackle -10 - 222 A /12- (not illustrated).

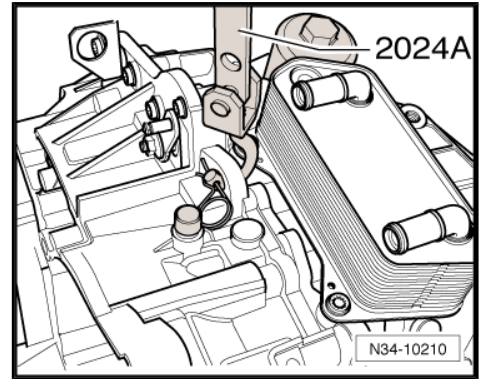

Gearbox may also be lifted with gearbox lifting tackle -3336- .

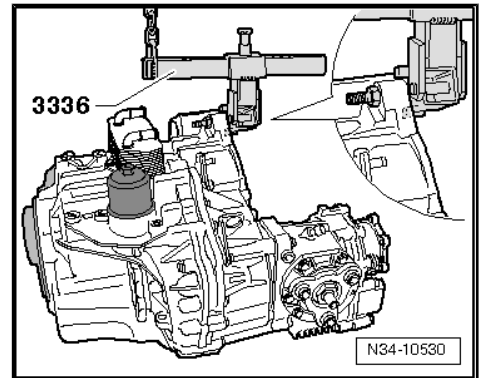

**Example: securing gearbox to assembly stand.**

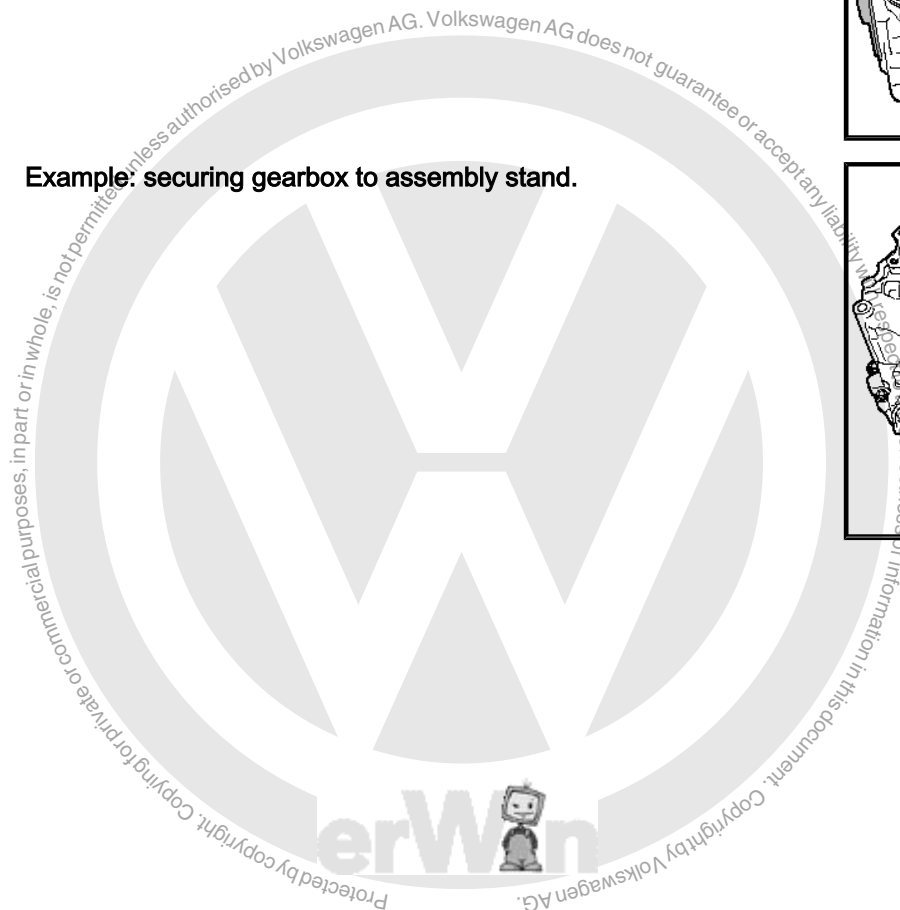
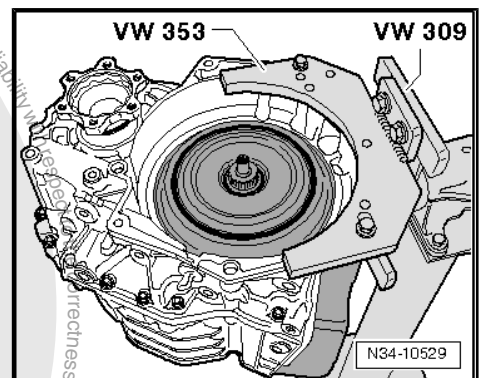



## 8 Changing oil and filter and adjusting oil level

This chapter shows you how the oil and filter are changed at the same time.

If the »old« filter is to remain in the gearbox, please refer to the notes about oil ⇒ [page 4](#) .

### Brief description

First read the oil temperature. If it is above 50 °C, let the gearbox cool off. With engine stopped, unscrew overflow pipe and drain oil. Then re-install overflow pipe and »overfill« gearbox.

Start engine and drain excess oil until oil level attains level of overflow pipe.

When replacing oil filter, it is often necessary to create access to filter. Air filter housing must be removed.

### Special tools and workshop equipment required

- ◆ Torque wrench -V.A.G 1331-
- ◆ Used oil collection and extraction unit -V.A.G 1782- or drip tray for workshop hoist -VAS 6208-
- ◆ Vehicle diagnostic tester , e.g. -VAS 5051-

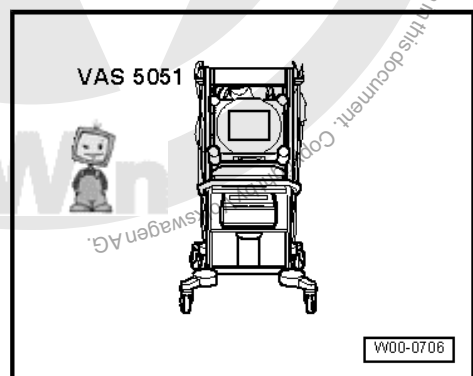
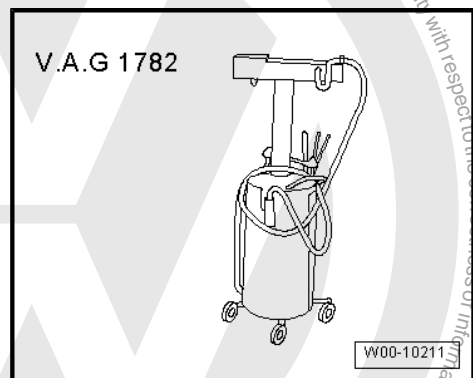
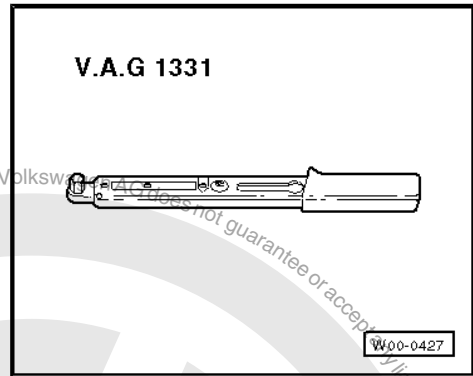
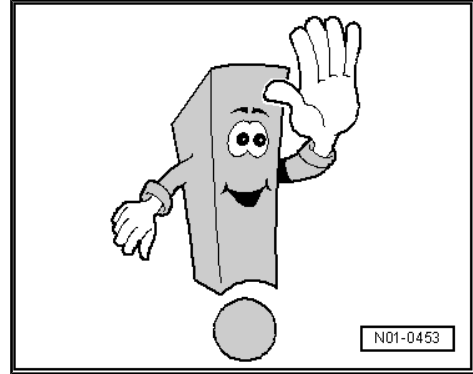



- ◆ Adapter for filling oil -VAS 6262- or -VAS 6262 A-

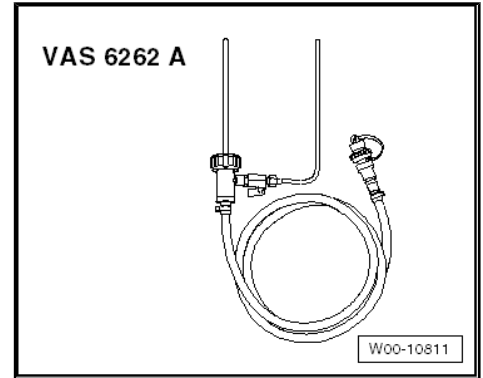

The oil is available as a Genuine part. Therefore the Genuine part number for it can be found in the ⇒ Electronic parts catalogue „ETKA“ .

#### Prerequisites

- Engine off.
- Vehicle level, all supports in lifting platform at same height.
- Noise insulation removed.
- Selector lever in „P“.
- Vehicle diagnostic tester is connected.
- At start of work, oil temperature must not be above 50 °C.

To gearbox manufacture date „20 September 2004“, gearboxes were constructed with 2 plugs.

It is important not to interchange these bolts. To change oil, only screw -A- on near ⇒ pendulum support.

**Gearboxes built after 20th September 2004, i.e. which are »later«, are fitted with bolt -A- only.**

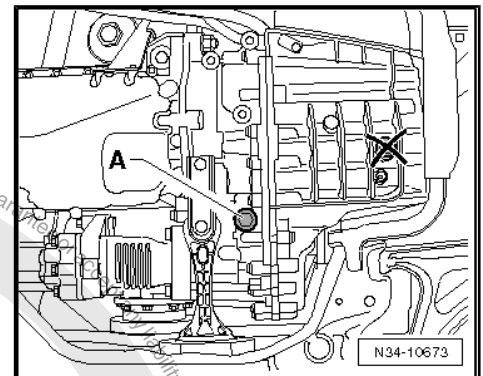

- Always renew oil seal -arrow-.

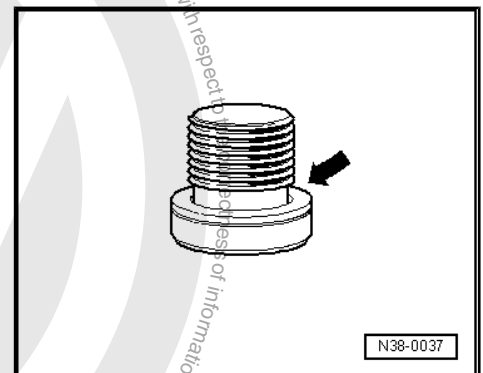



## 8.1 Changing oil and filter

### Perform the following steps:

- Please follow every one of the following instructions in the order given throughout the oil change.
- Connect vehicle diagnostic tester and identify the vehicle in **Guided functions**.
- **Dual clutch gearbox**
- **Check fluid level**
- If oil temperature is above 50 °C, let the gearbox cool off.

- Engine off - Do not start engine!

Do not start engine until instructed to do so. But not yet.

- Position used oil collection and extraction unit -V.A.G 1782- or drip tray -VAS 6208- under gearbox.

- Loosen filter housing through 7 turns.

- Wait for 10 seconds.

This way, the oil will flow from the filter housing back into the gearbox.

- Now remove filter housing.

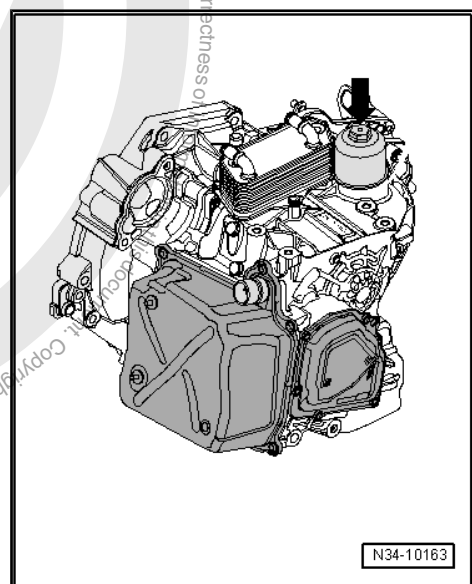
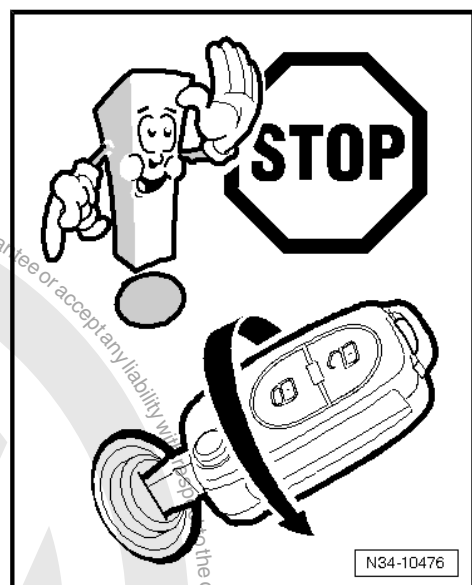
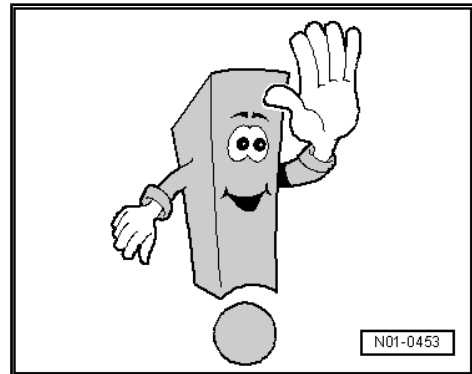



- After inserting new filter element with -shoulder- downwards, tighten housing to 20 Nm.

Please wipe away any oil that overflows.

- Raise vehicle.
- Remove noise insulation => Rep. gr. 50 ; Assembly overview - noise insulation .
- Position used oil collection and extraction unit -V.A.G 1782- or drip tray -VAS 6208- under gearbox.

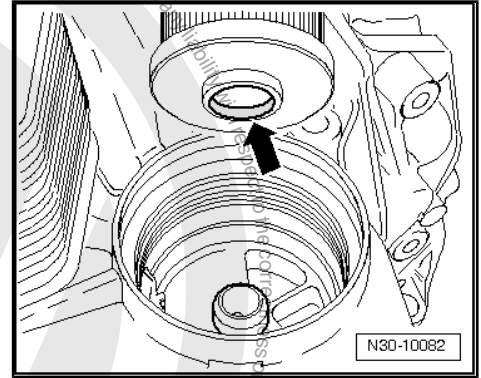

- Remove inspection plug near pendulum support -arrow-.

A black plastic »overflow tube« (with 8 mm hexagon socket head bolt, tightening torque 3 Nm) is located in this hole. Its length determines the oil level in the gearbox.

- Remove this oil pipe.

Approximately 5 litres of oil will run out.

- Screw overflow tube back in, 3 Nm.

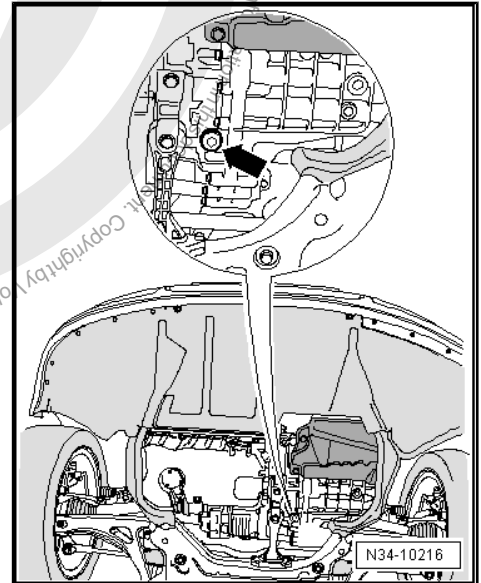

- Screw adapter -A- from -VAS 6262- or -VAS 6262 A- hand-tight into inspection hole.

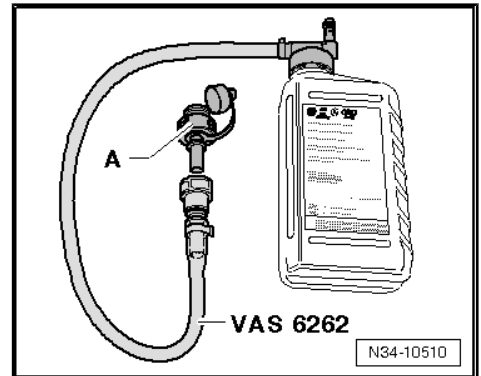

Shake oil cans before opening them.

- Add 5.5 l of dual clutch gearbox oil.

To change bottles, close tap or hold adapter for filling oil -VAS 6262 A- above gearbox.

- Continue to switch vehicle diagnostic tester until => DSG® oil temperature is displayed.

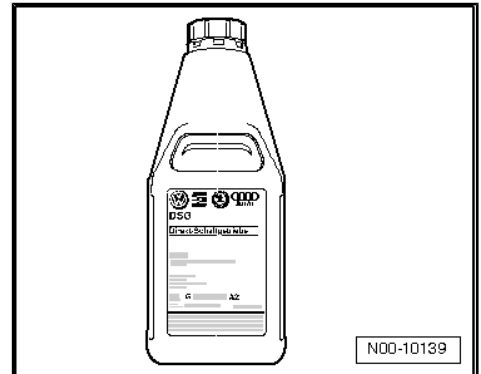



- Now start engine.
- Depress brake pedal and select each selector lever position for about 3 seconds. Move selector lever to position »P« position.

Do not switch off engine!

**When the oil temperature has reached 35 °C to 45 °C:**

- Disconnect quick-release coupling of adapter for filling oil - VAS 6262 A- with engine running.
- Let surplus oil drain out.
- When excess oil has run out (when it begins only to drip), remove adapter for filling oil -VAS 6262- or -VAS 6262 A- and install plug with new seal.

**Torque setting: 45 Nm**

- Switch off engine.

Oil which has run out cannot be filled again.

Please dispose of used oil properly → [page 4](#) .

This concludes the oil and filter change.

**The oil level in the gearbox is correctly set.**

- Install noise insulation⇒ Rep. gr. 50 ; Assembly overview - noise insulation .

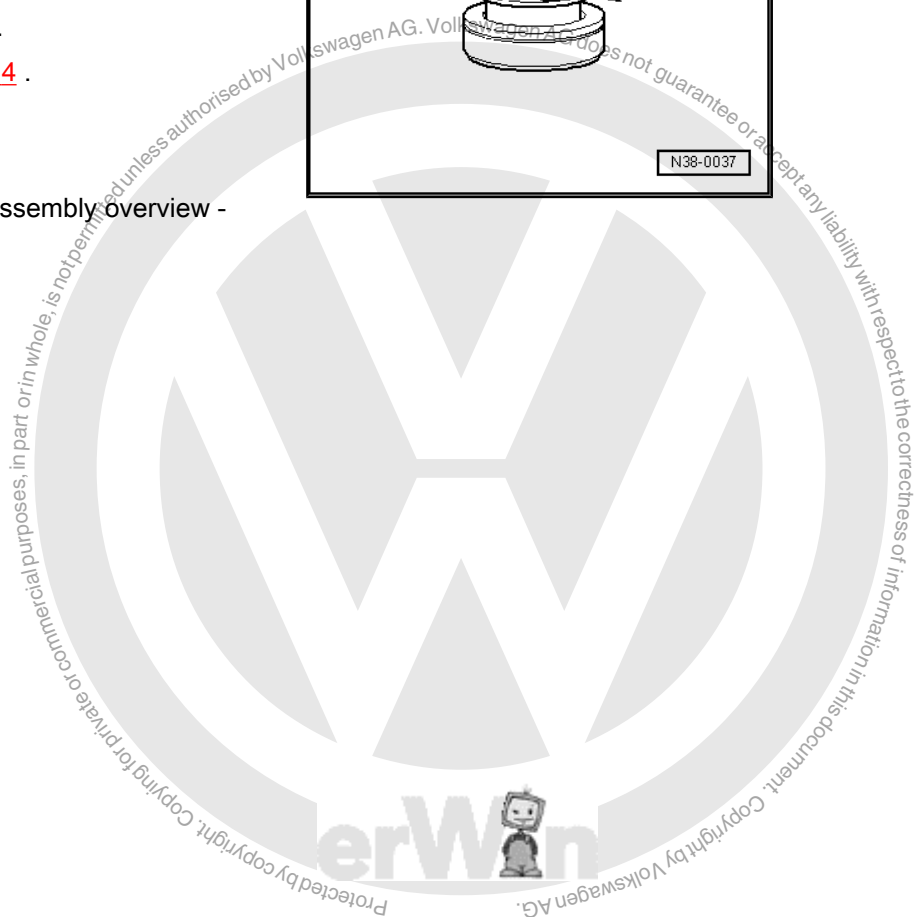
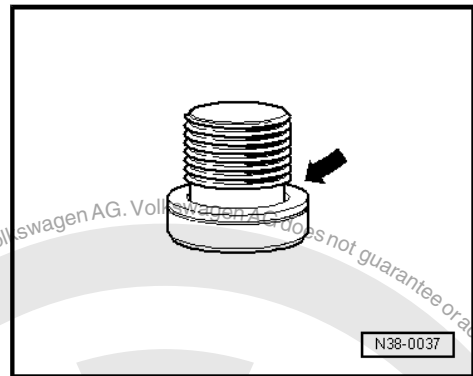
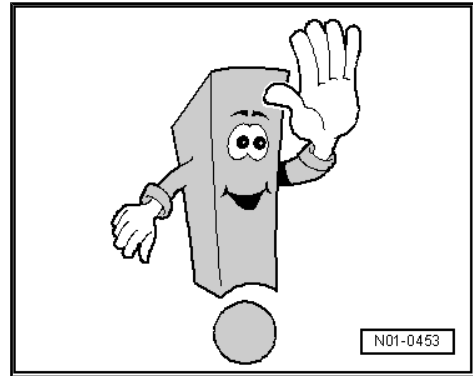



## 35 – Gears, shafts

- 1 Currently, no repairs can be made to gears and shafts





## 39 – Final drive - differential

### 1 Renewing seals for flange shaft or stub shaft

Do not remove both securing bolts in left and right flange shafts or right stub shaft at the same time. If the differential bevel gears turn, it is difficult to reinstall the bolts.

#### 1.1 Renewing oil seal for left flange shaft

##### Special tools and workshop equipment required

- ◆ Multipurpose tool -VW 771-
- ◆ Puller hooks -VW 771/37-
- ◆ Thrust piece -3305-
- ◆ Torque wrench -V.A.G 1331-
- ◆ Torque wrench -V.A.G 1332-
- ◆ Sealing grease -G 052 128 A1-

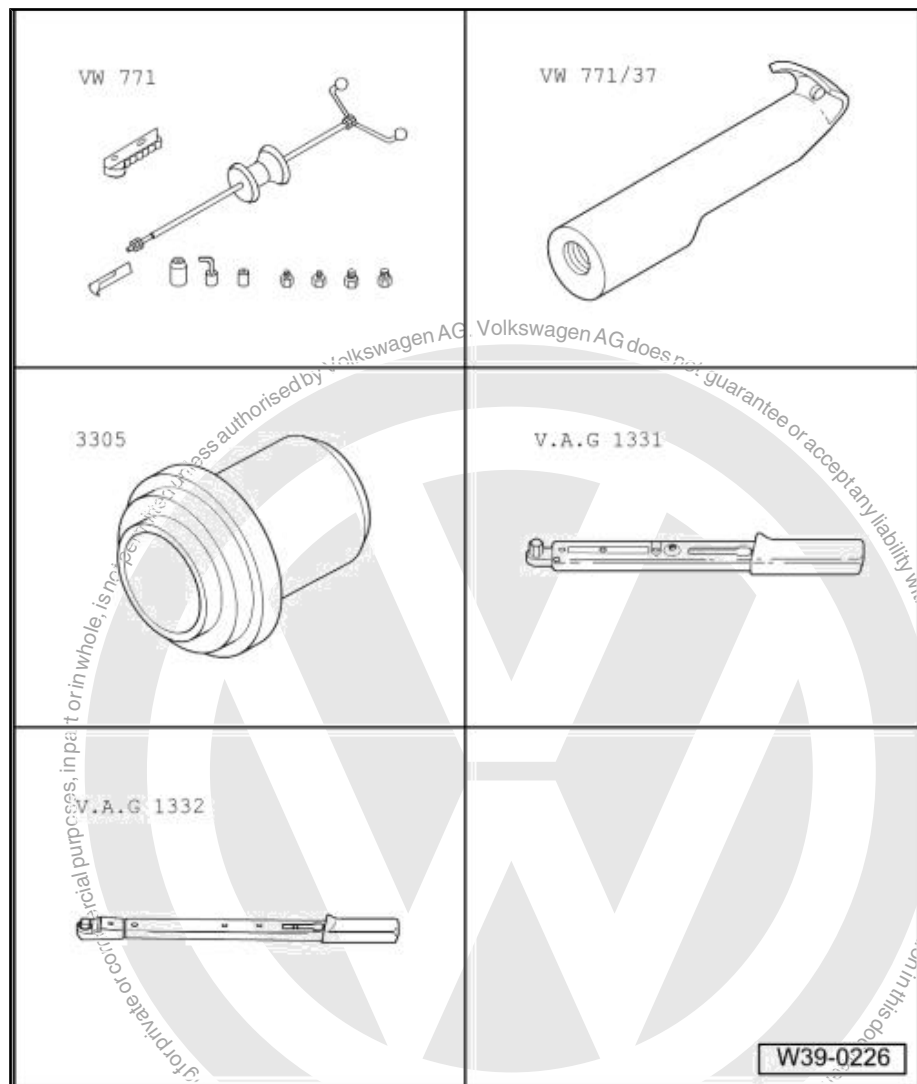



- ◆ Drip tray for workshop hoist -VAS 6208-

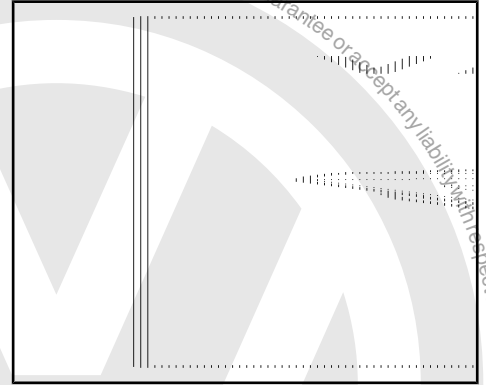

### 1.1.1 Removing

Perform the following steps:

- Remove left wheel.
- Remove noise insulation ⇒ Rep. gr. 50 ; Assembly overview - noise insulation .
- Remove lower part of front left wheel housing liner ⇒ Rep. gr. 66 ; Wheel housing liner; Removing and installing wheel housing liner .
- Remove left drive shaft ⇒ Rep. gr. 40 ; Repairing drive shafts; Removing and installing drive shafts .
- Place drip tray for workshop hoist -VAS 6208- under gearbox.
- Remove flange shaft securing bolt by screwing 2 bolts into flange and counterholding flange shaft with a lever.
- Pull out flange shaft together with compression spring.

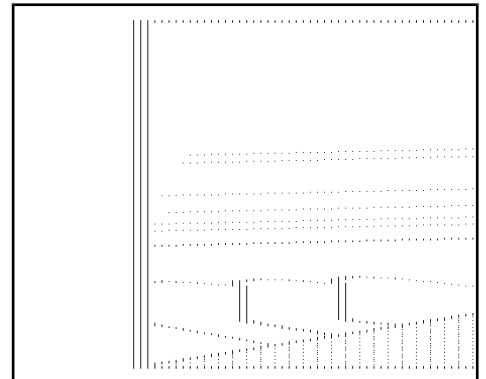

- Pull out flange shaft oil seal using multi-purpose tool -VW 771- and puller hooks -VW 771/37- .

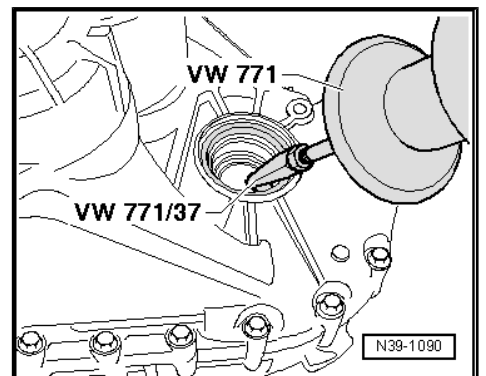

### 1.1.2 Installing

- Lightly oil outer circumference of new oil seal.



- Half-fill space between sealing lip and dust lip of new seal with sealing grease -G 052 128- -arrow-

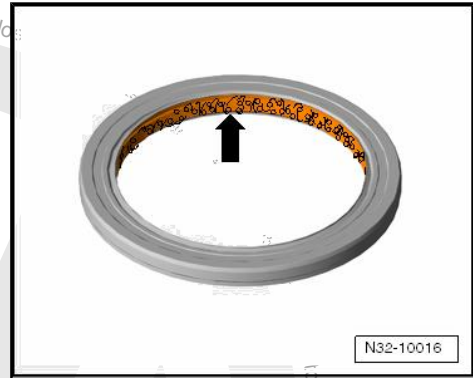

- Drive in new seal to stop, being careful not to cant seal.
- Insert flange shaft.
- Tighten new countersunk bolt to 30 Nm. When doing this, press flange shaft against gearbox so that bolt engages in thread.
- Install left drive shaft ⇒ Rep. gr. 40 ; Repairing drive shafts; Removing and installing drive shafts .
- Install left wheel housing liner ⇒ Rep. gr. 66 ; Wheel housing; Removing and installing wheel housing liner .
- Install left wheel ⇒ Rep. gr. 44 ; Torque settings for mounting wheels .
- Change oil for dual clutch gearbox ⇒ [page 90](#) .
- Install noise insulation ⇒ Rep. gr. 50 ; Noise insulation; Assembly overview - noise insulation .

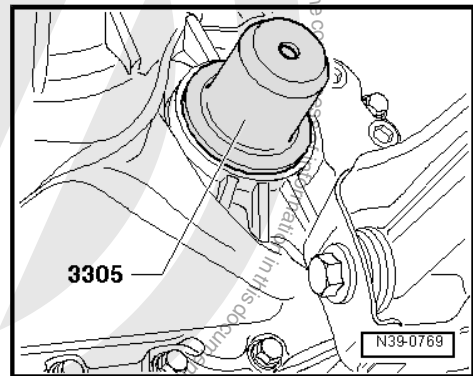

## 1.2 Renewing seals for right flange shaft or stub shaft

### Special tools and workshop equipment required

- ◆ Drift sleeve -3158-

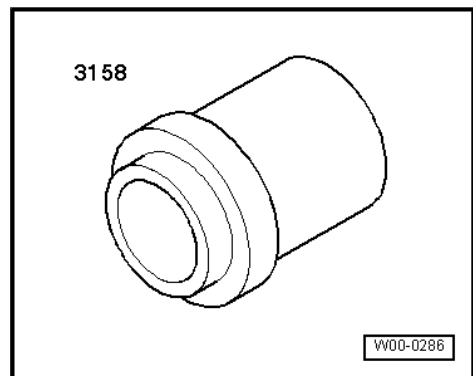



- ◆ Torque wrench -V.A.G 1331-

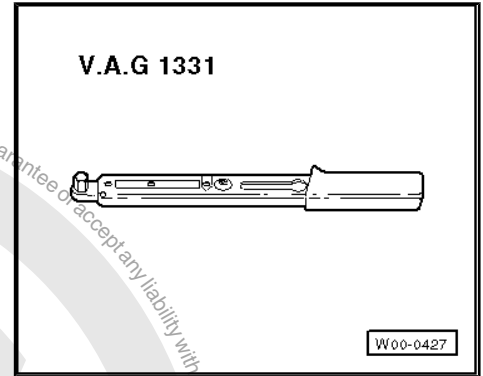

- ◆ Torque wrench -V.A.G 1332-
- ◆ Drip tray for workshop hoist -VAS 6208-

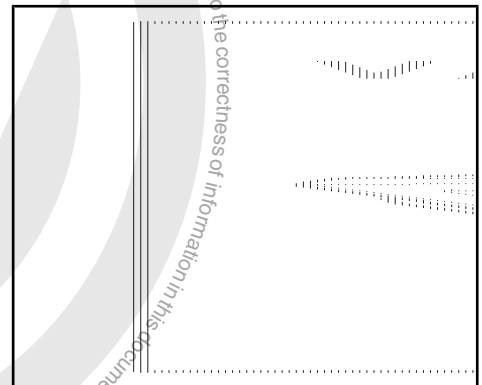

- ◆ Sealing grease -G 052 128 A1-
- ◆ All-purpose grease -G 052 735-

### 1.2.1 Removing

Perform the following steps:

- Remove right wheel.
- Remove noise insulation⇒ Rep. gr. 50 ; Noise insulation; Assembly overview - noise insulation .
- Remove drive shaft heat shield from engine -arrows-, if fitted.
- Remove right drive shaft ⇒ Rep. gr. 40 ; Repairing drive shafts; Removing and installing drive shafts .

Vehicles with intermediate shaft

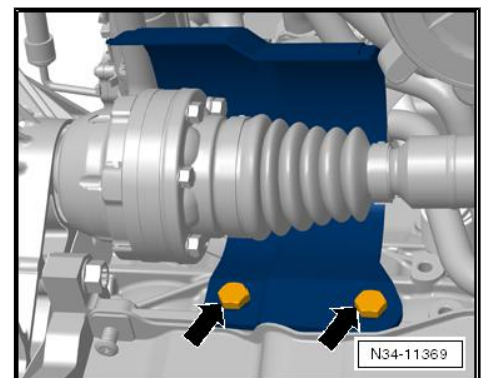



- After removing right drive shaft -A-, unbolt intermediate shaft -B- from bearing bracket -C- -arrows- and pull out stub shaft of gearbox.

**Continuation for all vehicles**

- Place drip tray for workshop hoist -VAS 6208- under gearbox.

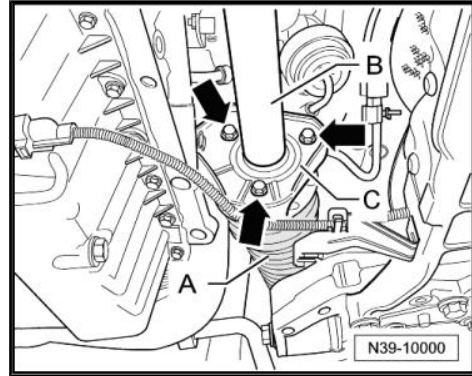

- Remove securing bolts -arrow- for stub shaft or flange shaft.
- Pull out stub shaft or flange shaft together with compression spring.
- Pry seal out using assembly lever.

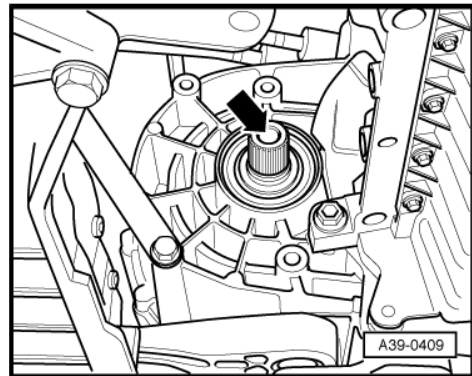

**1.2.2 Installing**

- Lightly oil outer circumference of new oil seal.
- Half-fill space between sealing lip and dust lip of new seal with sealing grease -G 052 128- -arrow-.

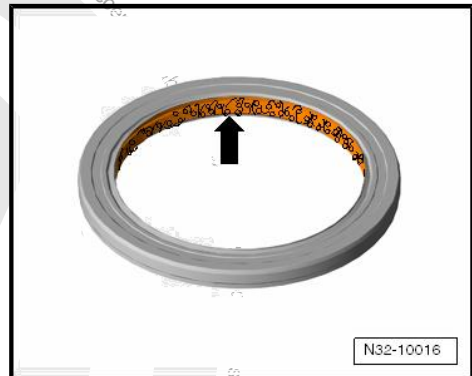

- Drive in new seal to stop, being careful not to cant seal.
- Insert stub shaft or flange shaft.
- Tighten new countersunk bolt to 30 Nm. When doing this, press stub shaft or flange shaft against gearbox so that bolt engages in thread.

**Vehicles with intermediate shaft**

- Renew O-ring of stub shaft.
- Grease splines of stub shaft with grease for clutch plate splines -G 000 100- .

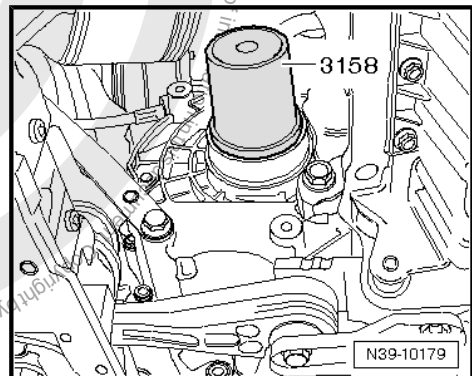



- Guide intermediate shaft -B- through bearing bracket -C- onto stub shaft of gearbox.
- Bolt intermediate shaft to bearing bracket to specified torque -arrows- => Rep. gr. 40 ; Repairing drive shaft; Removing and installing drive shafts .

#### Continuation for all vehicles

- Install right drive shaft => Rep. gr. 40 ; Repairing drive shafts; Removing and installing drive shafts .
- Install right wheel => Rep. gr. 44 ; Torque settings for mounting wheels .
- Change oil for dual clutch gearbox => [page 90](#) .
- Install noise insulation=> Rep. gr. 50 Noise insulation; Assembly overview - noise insulation .

