

PSCS 11-20V

EN

ORIGINAL INSTRUCTIONS
CORDLESS DRILL DRIVER



 **TROTEC**

Table of contents

Notes regarding the instructions 2

Safety 2

Information about the device 8

Transport and storage 10

Start-up 10

Operation 14

Available accessories 16

Errors and faults 16

Maintenance 17

Disposal 17

Declaration of conformity 18

Notes regarding the instructions

Symbols

 **Warning of electrical voltage**
This symbol indicates dangers to the life and health of persons due to electrical voltage.

 **Warning of explosive substances**
This symbol indicates dangers to the life and health of persons due to potentially explosive substances.

 **Warning**
This signal word indicates a hazard with an average risk level which, if not avoided, can result in serious injury or death.

 **Caution**
This signal word indicates a hazard with a low risk level which, if not avoided, can result in minor or moderate injury.

Note
This signal word indicates important information (e.g. material damage), but does not indicate hazards.

 **Info**
Information marked with this symbol helps you to carry out your tasks quickly and safely.

 **Follow the manual**
Information marked with this symbol indicates that the instructions must be observed.

 **Wear safety glasses**
Information marked with this symbol indicates that you should wear eye protection.

 **Wear a protective mask**
Information marked with this symbol indicates that you should wear a protective mask.

 **Wear protective clothing**
Information marked with this symbol indicates that you should wear protective clothing.

 **Wear protective gloves**
Information marked with this symbol indicates that you should wear protective gloves.

You can download the current version of the instructions and the EU declaration of conformity via the following link:



PSCS 11-20V



<https://hub.trotec.com/?id=42025>

Safety

General Power Tool Safety Warnings

 **Warning**
Read all safety warnings, instructions, illustrations and specifications provided with this power tool.
Failure to follow all instructions listed below may result in electric shock, fire and/or serious injury.
Save all warnings and instructions for future reference.

The term *power tool* in the warnings refers to your mains-operated (corded) power tool or battery-operated (cordless) power tool.

 **General Power Tool Safety Warnings – Work area safety**

- **Keep work area clean and well lit.** Clutter or dark areas invite accidents.
- **Do not operate power tools in explosive atmosphere, such as in the presence of flammable liquids, gases or dust.** Power tools create sparks which may ignite the dust or fumes.
- **Keep children and bystanders away while operating a power tool.** Distractions can cause you to lose control.



General Power Tool Safety Warnings – Electrical safety

- **Power tool plugs must match the outlet. Never modify the plug in any way. Do not use any adapter plugs with earthed (grounded) power tools.** Unmodified plugs and matching outlets will reduce risk of electric shock.
- **Avoid body contact with earthed or grounded surfaces, such as pipes, radiators, ranges and refrigerators.** There is an increased risk of electric shock if your body is earthed or grounded.
- **Do not expose power tools to rain or wet conditions.** Water entering a power tool will increase the risk of electric shock.
- **Do not abuse the cord. Never use the cord for carrying, pulling or unplugging the power tool. Keep cord away from heat, oil, sharp edges or moving parts.** Damaged or entangled cords increase the risk of electric shock.
- **When operating a power tool outdoors, use an extension cord suitable for outdoor use.** Use of a cord suitable for outdoor use reduces the risk of electric shock.
- **If operating a power tool in a damp location is unavoidable, use a residual current device (RCD) protected supply.** Use of an RCD reduces the risk of electric shock.



General Power Tool Safety Warnings – Personal safety

- **Stay alert, watch what you are doing and use common sense when operating a power tool. Do not use a power tool while you are tired or under the influence of drugs, alcohol or medication.** A moment of inattention while operating power tools may result in serious personal injury.



Use personal protective equipment. Always wear eye protection. Protective equipment such as a dust mask, non-skid safety shoes, hard hat or hearing protection used for appropriate conditions will reduce personal injuries.

- **Prevent unintentional starting. Ensure the switch is in the off-position before connecting to power source and/or battery pack, picking up or carrying the tool.** Carrying power tools with your finger on the switch or energising power tools that have the switch on invites accidents.
- **Remove any adjusting key or wrench before turning the power tool on.** A wrench or a key left attached to a rotating part of the power tool may result in personal injury.

- **Do not overreach. Keep proper footing and balance at all times.** This enables better control of the power tool in unexpected situation.
- **Dress properly. Do not wear loose clothing or jewellery. Keep your hair and clothing away from moving parts.** Loose clothes, jewellery or long hair can be caught in moving parts.
- **If devices are provided for the connection of dust extraction and collection facilities, ensure these are connected and properly used.** Use of dust collection can reduce dust-related hazards.
- **Do not let familiarity gained from frequent use of tools allow you to become complacent and ignore tool safety principles.** A careless action can cause severe injury within a fraction of a second.



General Power Tool Safety Warnings – Power tool use and care

- **Do not force the power tool. Use the correct power tool for your application.** The correct power tool will do the job better and safer at the rate for which it was designed.
- **Do not use the power tool if the switch does not turn it on and off.** Any power tool that cannot be controlled with the switch is dangerous and must be repaired.
- **Disconnect the plug from the power source and/or remove the battery pack, if detachable, from the power tool before making any adjustments, changing accessories, or storing power tools.** Such preventive safety measures reduce the risk of starting the power tool accidentally.
- **Store idle power tools out of the reach of children and do not allow persons unfamiliar with the power tool or these instructions to operate the power tool.** Power tools are dangerous in the hands of untrained users.
- **Maintain power tools and accessories. Check for misalignment or binding of moving parts, breakage of parts and any other condition that may affect the power tool's operation. If damaged, have the power tool repaired before use.** Many accidents are caused by poorly maintained power tools.
- **Keep cutting tools sharp and clean.** Properly maintained cutting tools with sharp cutting edges are less likely to bind and are easier to control.
- **Use the power tool, accessories and tool bits etc. in accordance with these instructions, taking into account the working conditions and the work to be performed.** Use of the power tool for operations different from those intended could result in a hazardous situation.

- **Keep handles and grasping surfaces dry, clean and free from oil and grease.** Slippery handles and grasping surfaces do not allow for safe handling and control of the tool in unexpected situations.

**General Power Tool Safety Warnings – Battery tool use and care**

- **Recharge only with charger specified by the manufacturer.** A charger that is suitable for one type of battery pack may create a risk of fire when used with another battery pack.
- **Use power tools only with specifically designed battery packs.** Use of any other battery packs may create a risk of injury and fire.
- **When battery pack is not in use, keep it away from other metal objects, like paper clips, coins, keys, nails, screws or other small metal objects, that can make a connection from one terminal to another.** Shorting the battery terminals together may cause burns or a fire.
- **Under abusive conditions, liquid may be ejected from the battery; avoid contact. If contact accidentally occurs, flush with water. If liquid contacts eyes, additionally seek medical help.** Liquid ejected from the battery may cause irritation or burns.
- **Do not use a battery pack or tool that is damaged or modified.** Damaged or modified batteries may exhibit unpredictable behaviour resulting in fire, explosion or risk of injury.
- **Do not expose a battery pack or tool to fire or excessive temperature.** Exposure to fire or temperature above 130 °C may cause explosion.
- **Follow all charging instructions and do not charge the battery pack or tool outside the temperature range specified in the instructions.** Charging improperly or at temperatures outside the specified range may damage the battery and increase the risk of fire.

**General Power Tool Safety Warnings – Charger use and care**

- **This charger can be used by children aged from 8 years and above and persons with reduced physical, sensory or mental capabilities or lack of experience and knowledge if they have been given supervision or instruction concerning use of the appliance in a safe way and understand the hazards involved. Children shall not play with the appliance.** Cleaning and user maintenance shall not be made by children without supervision.

- **Never insert non-rechargeable batteries into the charger.** A charger that is suitable for one type of battery pack may create a risk of fire and explosion, when used with another battery pack or non-rechargeable batteries.
- Only charge the Li-Ion battery "Multiflex 20 – 2.0 DC" (capacity of 2.0 Ah = 5 battery cells) with the charger "Multiflex 20 – 2.0 AC". The battery voltage must match the battery charging voltage of the charger.

**General Power Tool Safety Warnings – Service**

- **Have your power tool serviced by a qualified repair person using only identical replacement parts.** This will ensure that the safety of the power tool is maintained.
- **Never service damaged battery pack.** Service of battery packs should only be performed by the manufacturer or authorized service providers.

**Device-specific safety warnings for cordless drill drivers**

- **Secure the workpiece.** The grip of tensioning devices or a vice is more secure than holding the workpiece only by hand.
- **Hold the power tool firmly.** When tightening or loosening screws, high reaction torques can occur temporarily.
- **Immediately switch off the power tool if the insertion tool blocks.** Beware of high reaction torques causing a kickback.
- **Hold the power tool by insulated gripping surfaces, when performing an operation where the cutting accessory or fasteners may contact hidden wiring.** Cutting accessory contacting a "live" wire may make exposed metal parts of the power tool "live" and could give the operator an electric shock.
- **For any work on the device, as well as during transport or storage, set the switch for the rotational direction to centre position (locked).** This prevents unintentional starting of the power tool.
- **Regularly check the tool holder for wear or damage.**
- **Wait until the power tool has come to a standstill, before putting it down.**



Safety instructions when using long drill bits

- **Never operate at higher speed than the maximum speed rating of the drill bit.** At higher speeds, the bit is likely to bend if allowed to rotate freely without contacting the workpiece, resulting in personal injury.
- **Always start drilling at low speed and with the bit tip in contact with the workpiece.** At higher speeds, the bit is likely to bend if allowed to rotate freely without contacting the workpiece, resulting in personal injury.
- **Apply pressure only in direct line with the bit and do not apply excessive pressure.** Bits can bend causing breakage or loss of control, resulting in personal injury.

Intended use

Only use the device PSCS 11-20V:

- for screwing in and loosening screws,
- for drilling in wood, plastic, ceramic and metal,

whilst adhering to the technical data.

We recommend using the power tool with original Trotec accessories.

Foreseeable misuse

The device is not intended for drilling in concrete or natural stone.

Any other use than the one described in the chapter "Intended use" is regarded as reasonably foreseeable misuse.

Personnel qualifications

People who use this device must:

- have read and understood the instructions, especially the Safety chapter.

Safety signs and labels on the battery and the charger

Note

Do not remove any safety signs, stickers or labels from the device. Keep all safety signs, stickers and labels in legible condition.

The following safety signs and labels are attached to the battery:



Warning of explosion risk!

These symbols indicate the following:



Do not expose the battery pack or tool to fire or excessive temperature! Do not let the battery come into contact with water or fire! Avoid direct sunlight and moisture. There is a risk of explosion!

Never charge the battery at ambient temperatures below 10 °C or above 40 °C. Charging improperly or at temperatures outside the specified range may damage the battery and increase the risk of fire.



Observe the correct disposal of the battery!

This symbol indicates the following:

Ensure that the battery is disposed of correctly and never dispose of it in waste water or public waters. The battery contains irritating, caustic and toxic substances that pose significant risks to people and the environment.

The following safety signs and labels are attached to the charger:



This symbol indicates the following:

Read the instructions or operating manual before charging the battery.



This symbol indicates the following:

Only use the charger for charging the battery in dry interior spaces. Do not charge the device outdoors.

Personal protective equipment



Wear eye protection.

With it you protect your eyes from splintering, falling and flying pieces which could cause injuries.



Wear a protective mask.

It saves you from inhaling harmful dusts generated when processing workpieces.



Wear protective gloves.

They protect your hands from burns, crushing injuries and skin abrasions.



Wear tight-fitting protective clothing.

This protects you from the draw-in and entanglement hazard posed by rotating parts.

Residual risks



Warning of electrical voltage

Electric shock from insufficient insulation. Check the device for damages and proper functioning before each use. If you notice damages, no longer use the device. Do not use the device when the device or your hands are damp or wet!



Warning of electrical voltage

Work on the electrical components must only be carried out by an authorised specialist company!



Warning of electrical voltage

Before any work on the device, remove the mains plug from the mains socket and the battery from the device! Hold onto the mains plug while pulling the power cable out of the mains socket.



Warning of electrical voltage

There is a risk of a short-circuit due to liquids penetrating the housing! Do not immerse the device and the accessories in water. Make sure that no water or other liquids can enter the housing.



Warning of explosive substances

Do not expose the battery to temperatures above 45 °C! Do not let the battery come into contact with water or fire! Avoid direct sunlight and moisture. There is a risk of explosion!



Warning of hot surface

The insertion tool might still be hot after the application. Burn hazard when touching the insertion tool. Do not touch the insertion tool bare-handed! Wear protective gloves!



Warning

Toxic dusts!



The harmful / toxic dusts produced during operation pose of risk to the health of the operator and persons in the vicinity.



Wear eye protection and a dust mask!



Warning

Do not process materials containing asbestos. Asbestos is considered carcinogenic.



Warning

Make sure not to hit power, gas or water lines when working with a power tool. If necessary, use a pipe detector to check the wall you want to drill in or slit open.



Warning

Risk of injuries caused by flying parts or bursting tool heads.



Warning

Dangers can occur at the device when it is used by untrained people in an unprofessional or improper way! Observe the personnel qualifications!



Warning

The device is not a toy and does not belong in the hands of children.



Warning

Risk of suffocation! Do not leave the packaging lying around. Children may use it as a dangerous toy.



Caution

Vibration emissions can cause a health hazard if the device is used for an extended period of time or if it is not properly handled and maintained.



Caution

Keep a sufficient distance from heat sources.

Note

If you store or transport the device improperly, the device may be damaged.

Note the information regarding transport and storage of the device.

Note

Only change the rotational direction when the device is at a standstill! Otherwise the device might be damaged.

Note

Set the torque and rotational direction according to the operating mode. A wrong selection may damage the device.

Behaviour in the event of an emergency / emergency stop function

Emergency stop:

Removing the battery results in the function of the device stopping immediately. Leave the battery out in order to secure the device against accidental switch-on.

Behaviour in the event of an emergency:

1. Switch the device off.
2. In the event of an emergency, remove the battery from the device: Hold the release button of the battery and pull the battery off the device as described in chapter "Removing the battery".
3. Do not insert the battery if the device is defective.

Information about the device

Device description

The cordless drill driver PSCS 11-20V has two speed levels: while the first speed level is suitable for screwing, drilling can be performed using the second speed level.

The integrated torque selection, including one drilling setting, allows you to use the optimum power for every application, adapted to the material and screw size.

The keyless drill chuck with automatic spindle lock further enables an easy and tool-free exchange of the insertion tools.

The integrated LED work lamp offers an improved illumination of the workpiece or working surface,

and the optionally mountable belt clip facilitates transport and provides faster access to the device.

The battery comes with its own battery level indication. As a result you can check the current charging status without having to connect it to the device.

Device depiction

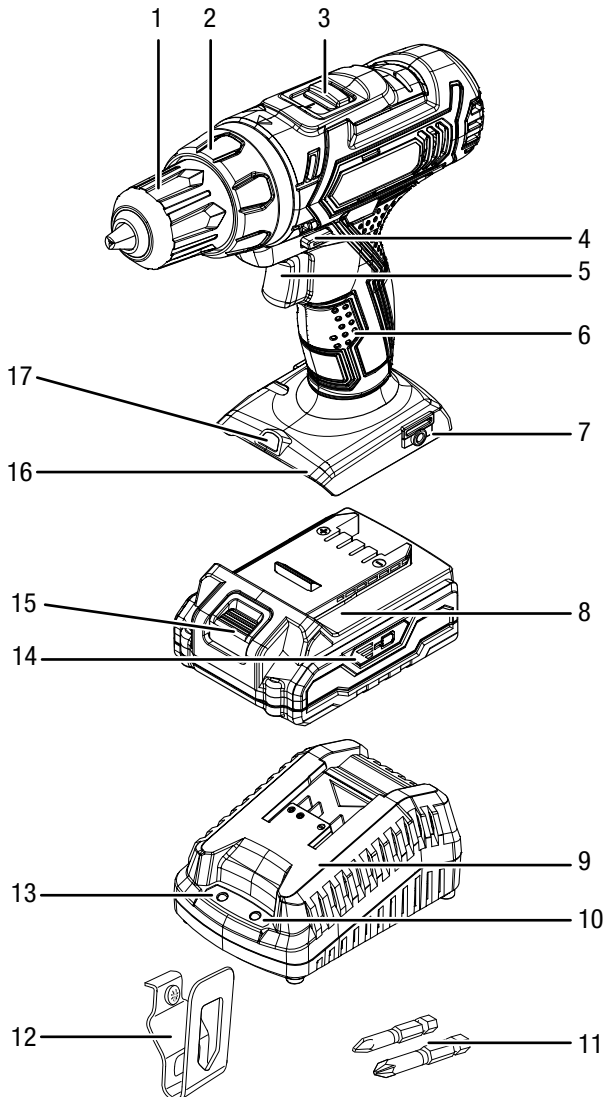



No.	Designation
1	Keyless drill chuck
2	Torque selection
3	Gear selection (2 speed levels)
4	Clockwise / counter-clockwise rotation, lock
5	On/off switch (speed regulation)
6	Handle
7	Attachment for belt clip
8	Battery
9	Quick charger
10	Red battery LED (battery charging)
11	Bits
12	Belt clip
13	Green battery LED (quick charger ready for operation)
14	3-stage battery level indication
15	Unlocking button
16	Battery holder
17	LED work lamp

Scope of delivery

- 1 x Cordless drill driver
- 1 x Rechargeable battery
- 2 x Bits (50 mm)
- 1 x Quick charger
- 1 x Belt clip
- 1 x Transport case
- 1 x Manual

Technical data

Parameter	Value
Model	PSCS 11-20V
Nominal voltage	20 V $\overline{=}$
Idle speed	
1. Speed level	0 – 400 rpm
2. Speed level	0 – 1550 rpm
Torque settings	25 +1
Chucking range	max. 13 mm
Max. drilling diameter	
Wood	30 mm
Metal	13 mm
Max. torque	35 Nm
Weight	1.7 kg
Battery	Multiflex 20--2.0 DC
Type	Li-ion
Nominal voltage	20 V $\overline{=}$
Capacity	2 Ah
Quick charger	Multiflex 20--2.0 AC
Input	
Nominal voltage	230 – 240 V / 50 Hz
Power input	65 W
Output	
Nominal voltage	21.5 V $\overline{=}$
Charging current	2.4 A
Fusing 	3.15 A (slow-blowing)
Charging time	1 h
Protection class	II / 
Sound values according to EN 62841	
Sound pressure level	72.20 dB (A)
Sound power level	83.20 dB (A)
Uncertainty K	3 dB (A)
Vibration information according to EN 62841	
Vibration emission value for drilling in metal a_h	1.643 m/s ²
Uncertainty K	1.5 m/s ²

Information on noise and vibration:

- The specified total vibration **and noise emission values** were measured by means of a test procedure standardized in EN 62841 and can be consulted for the comparison of one power tool with another.
- The specified total vibration **and noise emission values** can also be used for preliminary load assessment.



Caution

Vibration emissions can cause a health hazard if the device is used for an extended period of time or if it is not properly handled and maintained.

- The actual vibration **and noise emission** may differ from the stated values during operation of the power tool. This depends on how the power tool is used and especially on the type of workpiece being processed. Try to keep the vibration load to a minimum. Exemplary measures for reducing the vibration load include wearing gloves during operation of the tool and the limitation of working hours. All parts of an operating cycle must be considered for this (e.g. times at which the power tool is switched off and times when it is switched on but runs without load).

Transport and storage

Note

If you store or transport the device improperly, the device may be damaged.

Note the information regarding transport and storage of the device.

Transport

For transporting the device, use the transport case included in the scope of delivery in order to protect the device from external influences.

Before transporting the device, observe the following:

- Switch off the device by setting the switch for clockwise/ counter-clockwise rotation to centre position (lock).
- Hold onto the mains plug while pulling the power cable of the charger out of the mains socket.
- Allow the device to cool down.
- Remove the battery from the device.
- Remove the tool from the tool holder.

The supplied Li-ion batteries are subjects to the requirements of dangerous goods legislation.

Observe the following when transporting or shipping Li-ion batteries:

- The user may transport the batteries by road without any additional requirements.
- If transport is carried out by third parties (e.g. air transport or forwarding company), special requirements as to packaging and labelling must be observed. This includes consulting a dangerous goods specialist when preparing the package.
 - Only ship batteries if their housing is undamaged.
 - Mask open terminals with tape and pack the battery in a way that it cannot move inside the packaging.
 - Please also observe any other national regulations.

Storage

Before storing the device, observe the following:

- Switch off the device by setting the switch for clockwise/ counter-clockwise rotation to centre position (lock).
- Hold onto the mains plug while pulling the power cable of the charger out of the mains socket.
- Allow the device to cool down.
- Remove the battery from the device.
- Remove the tool from the tool holder.
- Clean the device as described in the Maintenance chapter.
- For storing the device, use the transport case included in the scope of delivery in order to protect the device from external influences.
- Do not store Li-ion batteries which are completely discharged. Storing discharged batteries can lead to a deep discharge and thus damage the battery.

When the device is not being used, observe the following storage conditions:

- Dry and protected from frost and heat
- Ambient temperature below 45 °C
- Protected from dust and direct sunlight inside the transport case

Start-up

Unpacking the device

- Take the transport case out of the packaging.



Warning of electrical voltage

Electric shock from insufficient insulation.

Check the device for damages and proper functioning before each use.

If you notice damages, no longer use the device.

Do not use the device when the device or your hands are damp or wet!

- Check the contents of the transport case for completeness and look for damages.



Warning

Risk of suffocation!

Do not leave the packaging lying around. Children may use it as a dangerous toy.

- Dispose of the packaging material according to the national regulations.

Charging the battery

Note

The battery can be damaged in case of improper charging.

Remove the charger's mains plug before inserting or removing the battery.

Never charge the battery at ambient temperatures below 10 °C or above 40 °C.

The battery is partially charged upon delivery to avoid damage to the battery caused by a deep discharge.

Prior to initial start-up and when the battery is low (only the red LED in the battery level indication (14) is illuminated), the battery should be charged. To do so, please proceed as follows:

1. Slide the battery (8) onto the quick charger (9) upside down until it locks in place.

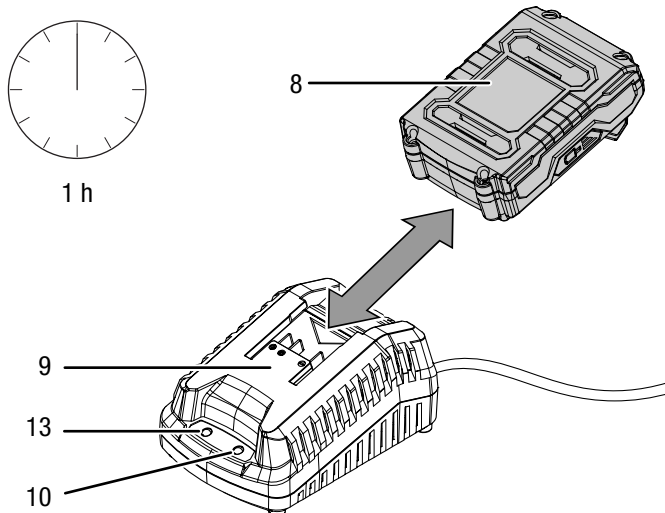

2. Insert the mains plug of the quick charger (9) into a properly fused mains socket.
 - ⇒ The red battery LED (10) lights up.
 - ⇒ Charging requires approx. one hour.
3. Wait until the red battery LED (10) goes off and the green battery LED (13) lights up.
 - ⇒ The battery (8) is fully charged.
4. Hold onto the mains plug while pulling the power cable of the quick charger (9) out of the mains socket.
 - ⇒ The battery (8) and the quick charger (9) may have become warm during charging.
 - Allow the battery (8) to cool down to room temperature.
5. Take the battery (8) out of the quick charger (9) by pressing and holding the release button (15) and pulling the battery (8) off the quick charger (9).

Inserting the battery

1. Set the switch for clockwise / counter-clockwise rotation (4) to centre position (lock).
2. Slide the battery (8) onto the device until it locks in place.

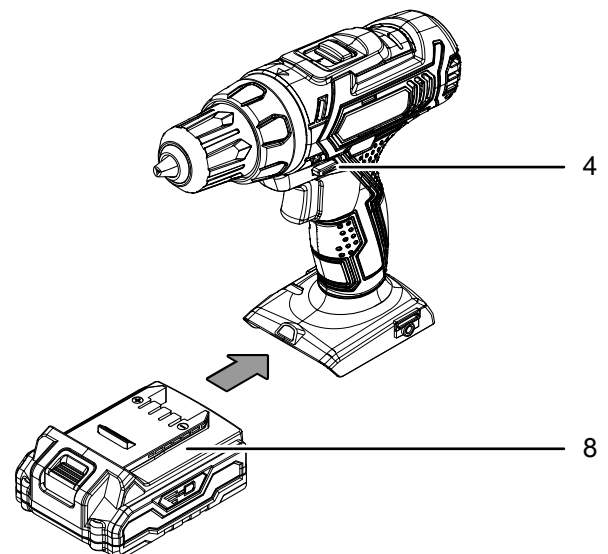

Removing the battery

1. Set the switch for clockwise / counter-clockwise rotation (4) to centre position (lock).
2. Detach the battery (8) from the device by pressing and holding the unlocking button (15, I.) and pulling the battery off the device (II.).

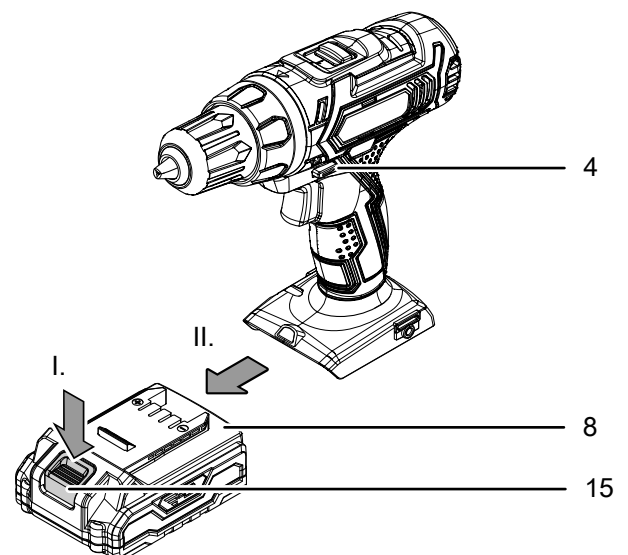

3. If required, charge the battery (8) as described in the section *Charging the battery*.

Checking the battery charging status

The battery comes with an integrated battery level indication. The battery status is displayed as follows by the three LEDs of the battery level indication (14):

LED colour	Meaning
Green – Orange – Red	maximum charge / power
Orange – Red	medium charge / power
Red	weak charge – Recharge the battery.

1. Press on the battery icon (18) on the battery (8).
 ⇒ You can read the battery status from the battery level indication (14).

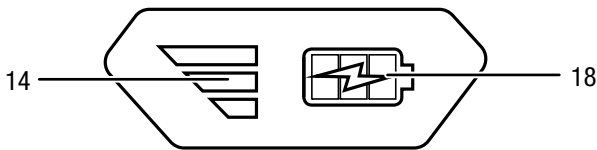

Tool change

The device is equipped with a fully automatic spindle lock. When the tool is at a standstill, the motor's drive train is locked so that the keyless drill chuck can be opened. Please proceed as follows to remove or insert tools:

1. Set the switch for clockwise / counter-clockwise rotation (4) to centre position (lock).
2. Turn the keyless drill chuck (1) counter-clockwise to open it.

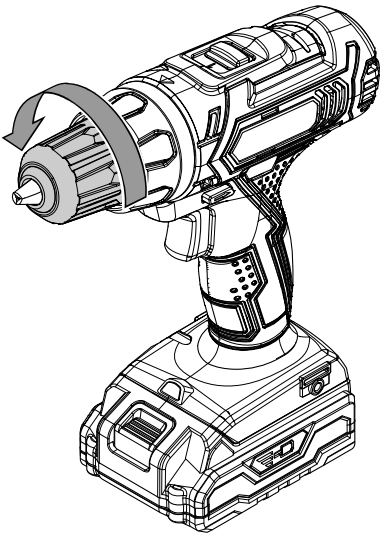

4. Insert the appropriate (drill) bit into the drill chuck.

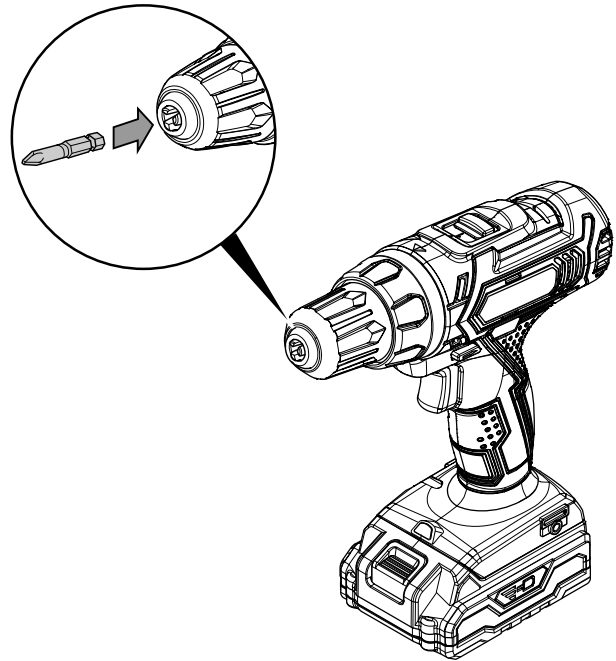

5. Tighten the keyless drill chuck (1) by turning clockwise.

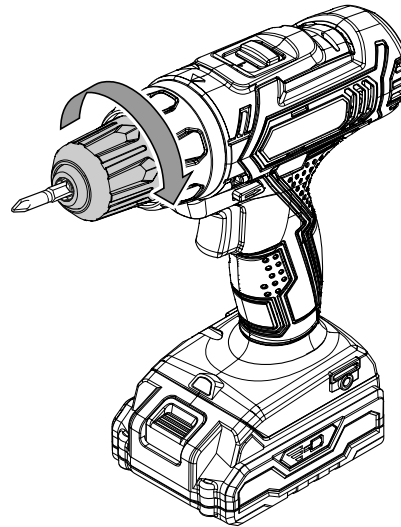

3. If necessary, take the (drill) bit out of the drill chuck.

Torque selection / drilling setting

Using the torque selection, you can choose the desired, optimal torque setting.

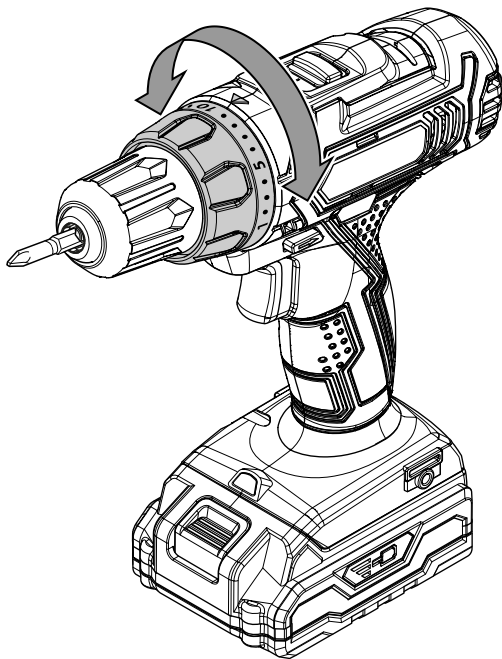

- Select a low torque for smooth-running screws or soft materials.
- Select a high torque for tight screws and hard materials as well as for unscrewing.
- For drilling, select the drilling setting indicated by the symbol .

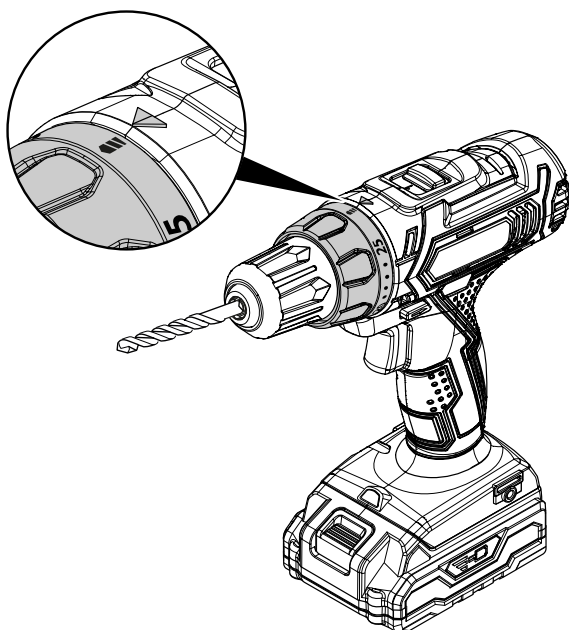

Info

When unscrewing, note the setting of the rotational direction! On the clockwise / counter-clockwise rotation direction indicator (4) you can see in which direction the screws will be screwed.

Do not use the drilling setting  for screwing!

Two-speed gear

Note

Only use the gear selection when the device is at a standstill! Otherwise the device might be damaged.

1. Slide the gear selection (3) to the desired position.

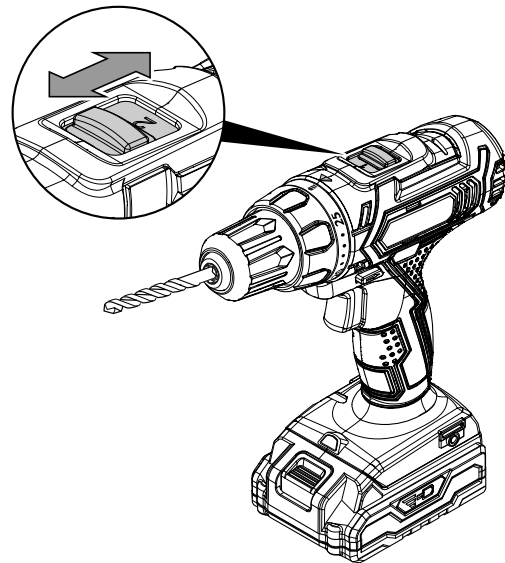

- ⇒ Speed level 1: Speed of up to 400 rpm, suitable for all screwing applications.
- ⇒ Speed level 2: Speed of up to 1550 rpm, suitable for drilling.

Mounting the belt clip

Optionally, you can mount the belt clip included in the scope of delivery to the device.

1. Set the switch for clockwise / counter-clockwise rotation (4) to centre position (lock).
2. Loosen the screw at the attachment (7) for the belt clip.
3. Fasten the belt clip (12) to the belt clip attachment (7) by means of the screw.

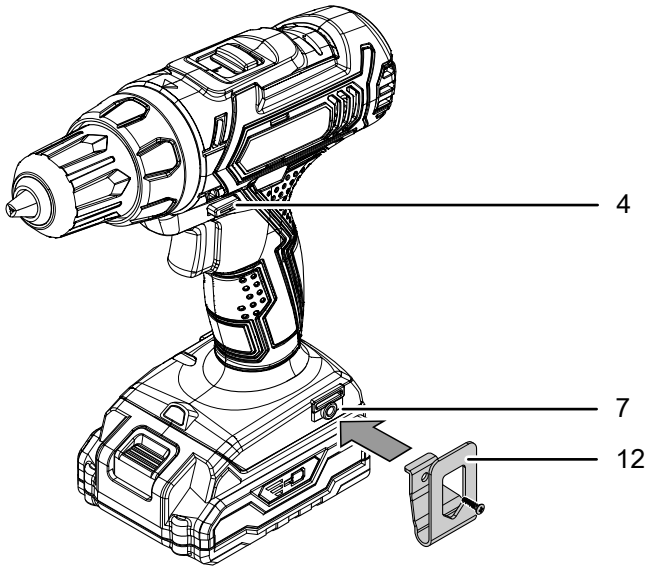

Operation

Tips and notes on handling the cordless drill driver

General information:

- Check the tool in the keyless drill chuck for correct fit before every application. It must be firmly locked and centred in the drill chuck.
- Screw bits are marked with their size and shape. If you are unsure, check whether the bit can be firmly tightened in the keyless drill chuck without clearance.
- The centre position of the clockwise/counter-clockwise rotation switch (lock) is suited for work breaks or (drill) bit exchange.

Screwing:

- In case of soft wood, screws can be screwed in without pre-drilling.
- In case of hard wood or large screws, it is recommended to use a drill for pre-drilling.
- When using countersunk screws, the drill hole should be countersunk beforehand.
- Especially smaller screws and bits may be damaged when selecting an excessive torque and / or speed at the tool.

Drilling in general:

- Take short breaks regularly during drilling. When doing so, take the drill bit out of the drill hole so that the drill bit can cool down.
- Secure the workpiece in a tensioning device or vice.
- Select the speed depending on the material characteristics and the size of the drill bit:
 - High speed for small drilling diameter or soft material
 - Low speed for large drilling diameter or hard material
- Use a suitable aid to mark the intended location of the drill hole.
- Select a low speed for spudding.

Drilling in metal:

- Use suitable metal drill bits (e.g. drill bits made of *high-speed steel* (HSS)).
- For larger drilling diameters, use a smaller drill bit for pre-drilling.
- To achieve ideal results, the drill bit should be cooled with a suitable lubricant.
- Metal drill bits may also be used for drilling in plastic.

Drilling in wood:

- Use drill bits suitable for wood.
- Place a block of wood under the workpiece or drill in from both sides so that the wood cannot break off when it is being drilled through.
- Use a wood drill bit with centring tip. For deep drill holes, use an auger bit; for large drilling diameters, use a Forstner bit.

Selecting the rotational direction

Note

Only change the rotational direction when the device is at a standstill! Otherwise the device might be damaged.

The motor's rotational direction can be changed by means of the switch for clockwise / counter-clockwise rotation (4).

1. Press the switch for clockwise / counter-clockwise rotation (4) in all the way on that side towards which the motor shall rotate.

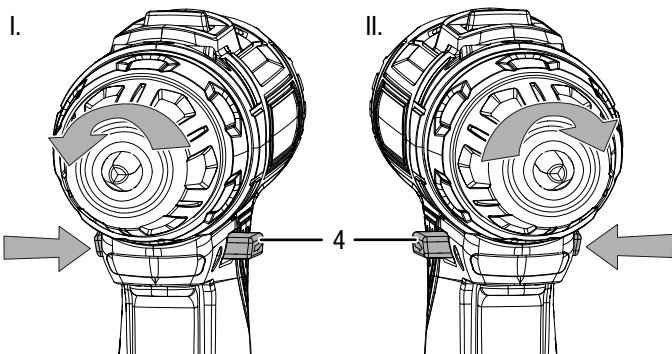

I. Screwing in

II. Unscrewing

2. Carry out a short test run to see whether the rotational direction matches the intended application. A wrong rotational direction may damage the tool and / or workpiece.
3. If required, set the switch for clockwise / counter-clockwise rotation (4) to centre position (lock) to block the on/off switch (5).

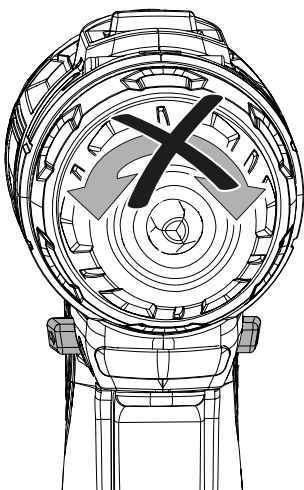

Switching the device on and off

The device has an infinitely variable speed control. The more firmly you push the on/off switch (5), the higher is the speed.

1. Check whether the tool clamped in and the torque setting selected are suitable for the intended application.
2. Check whether the workpiece is secured and the worktop prepared correspondingly.
3. Press and hold the on/off switch (5) during screwing or drilling.
 - ⇒ The device operates with the previously selected settings.
 - ⇒ The LED work lamp (17) is illuminated.

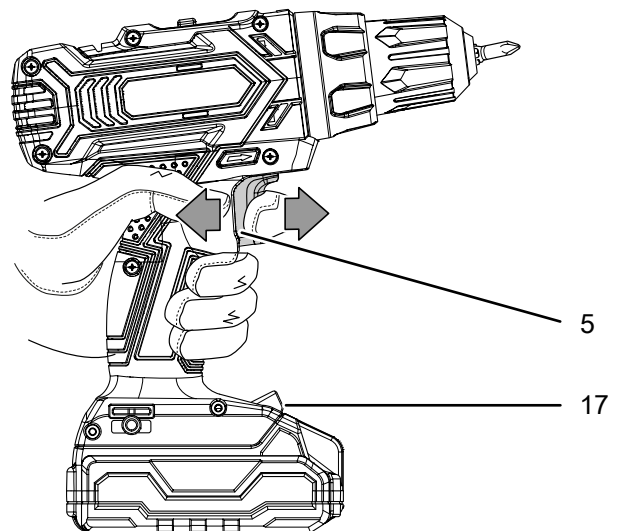

4. Let go of the on/off switch (5) to stop the device.
 - ⇒ The LED work lamp (17) turns off.



Info

The motor has an integrated brake that quickly stops the motor once you let go of the on/off switch (5).

Shutdown

1. Set the switch for clockwise / counter-clockwise rotation (4) to centre position (lock).
2. If required, allow the device to cool down.
3. Remove the battery from the device (see Start-up chapter).
4. Remove the tool from the device (see Start-up chapter).
5. Clean the device according to the Maintenance chapter.
6. Store the device according to the Storage chapter.

Available accessories



Warning

Only use accessories and additional equipment specified in the instructions.
Using insertion tools or accessories other than those specified in the instructions may cause a risk of injury.

Accessories	Article number
Multiflex 20V 2.0 Ah spare battery	6.200.000.303
Screw bit set, 32-piece	6.200.001.001
Wood drill bit set, 15-piece	6.200.001.101
Metal drill bit set HSS, 15-piece	6.200.001.131

Errors and faults

The device has been checked for proper functioning several times during production. If malfunctions occur nonetheless, check the device according to the following list.

Troubleshooting tasks which require the housing to be opened must only be carried out by an authorized specialist electrical company or by Trotec.

Light smoke or odour is emitted during the first use:

- This is not a fault. These phenomena disappear after a brief runtime.

The battery does not charge:

- Check whether the battery is correctly connected to the quick charger.
Slide the battery into the quick charger in a way that the battery terminals engage in the quick charger. The battery must lock in place in the quick charger.
- Check the power connection.
- Check the power cable and mains plug for damages.
- Check the fuse (home).
- Check the quick charger for damages. Should the quick charger be damaged, stop using it. Contact the Trotec customer service.
- Check the battery terminals for dirt. Remove any dirt.
- The battery might be defective and have to be replaced. Only use batteries of the same type.

The device does not start:

- The battery power might be too low. Recharge the battery.
- Check whether the battery is correctly connected to the device.
Slide the battery onto the device in a way that the battery terminals engage. The battery must lock in place in the device.
- Check the position of the clockwise/counter-clockwise rotation switch. The switch must be pressed in all the way. If the clockwise/counter-clockwise rotation switch is in centre position (lock), the on/off switch is blocked.
- Check the battery terminals for dirt. Remove any dirt.



Info

Wait for at least 10 minutes before switching the device back on.

The drill bit does not penetrate / hardly penetrates the material:

- Check whether the correct torque setting is selected. The drilling setting  should be selected.
- If necessary, increase the speed by switching to a high speed level (2nd speed level).
- Check whether the correct drill bit is selected.
- Check whether the device is set to counter-clockwise rotation. For drilling, it is necessary to switch over to clockwise rotation.
- Check whether the characteristics of the material require the use of a hammer drill or impact drill.

The on/off switch cannot be pressed:

- Check whether the clockwise/counter-clockwise rotation switch is in centre position (lock). Set the desired rotational direction to unlock the tool.

Note

Wait for at least 3 minutes after maintenance and repair work. Only then switch the device back on.

The device still does not operate correctly after these checks:

Please contact the customer service. If necessary, bring the device to an authorised specialist electrical company or to Trotec for repair.

Maintenance

Activities required before starting maintenance



Warning of electrical voltage

Do not touch the mains plug or the battery with wet or damp hands.

- Switch the device off.
- Allow the device to cool down completely.
- Remove the battery from the device.



Warning of electrical voltage

Maintenance tasks which require the housing to be opened must only be carried out by authorised specialist companies or by Trotec.

Notes on maintenance

Inside the device, there are no parts that need to be maintained or lubricated by the user.

Safety signs on the battery and the charger

Check the safety signs attached to the battery and the charger at regular intervals. Replace illegible safety signs!

Cleaning

The device should be cleaned before and after each use.

Note

The device does not have to be lubricated after cleaning.



Warning of electrical voltage

There is a risk of a short-circuit due to liquids penetrating the housing!

Do not immerse the device and the accessories in water. Make sure that no water or other liquids can enter the housing.

- Clean the device with a soft, damp and lint-free cloth. Make sure that no moisture enters the housing. Protect electrical components from moisture. Do not use any aggressive cleaning agents such as cleaning sprays, solvents, alcohol-based or abrasive cleaners to dampen the cloth.
- Dry the device with a soft, lint-free cloth.
- Dry the bits with a soft, lint-free cloth.
- Remove any drilling dust and, if applicable, wood chips from the keyless drill chuck.
- Keep the connecting terminals on the device and charger clean.
- Keep the ventilation openings free from dust deposits to prevent overheating of the motor.

Disposal



The icon with the crossed-out waste bin on waste electrical or electronic equipment stipulates that this equipment must not be disposed of with the household waste at the end of its life. You will find collection points for free return of waste electrical and electronic equipment in your vicinity. The addresses can be obtained from your municipality or local administration. You can also find out about other return options that apply for many EU countries on the website <https://hub.trotec.com/?id=45090>. Otherwise, please contact an official recycling centre for electronic and electrical equipment authorised for your country.

The separate collection of waste electrical and electronic equipment aims to enable the re-use, recycling and other forms of recovery of waste equipment as well as to prevent negative effects for the environment and human health caused by the disposal of hazardous substances potentially contained in the equipment.



In the European Union, batteries and accumulators must not be treated as domestic waste, but must be disposed of professionally in accordance with Directive 2006/66/EC of the European Parliament and of the Council of 6 September 2006 on batteries and accumulators. Please dispose of batteries and accumulators according to the relevant legal requirements.

Declaration of conformity

Declaration of conformity in accordance with the EC Machinery Directive 2006/42/EC, Annex II, Part 1, Section A

We – Trotec GmbH – declare in sole responsibility that the product designated below was developed, constructed and produced in compliance with the requirements of the EC Machinery Directive in the version 2006/42/EC.

Product model / Product: PSCS 11-20V

Product type: cordless drill driver

Year of manufacture as of: 2021

Relevant EU directives:

- 2011/65/EU: 01/07/ 2011
- 2012/19/EU: 24/07/2012
- 2014/30/EU: 29/03/2014
- 2015/863/EU: 31/03/2015

Applied harmonised standards:

- EN 55014-1:2017
- EN 60745-2-2:2010
- EN 62841-1:2015
- EN 62841-2-1:2018

Applied national standards and technical specifications:

- EN 55014-2:2015

Manufacturer and name of the authorised representative of the technical documentation:

Trotec GmbH

Grebbener Straße 7, D-52525 Heinsberg

Phone: +49 2452 962-400

E-mail: info@trotec.de

Place and date of issue:

Heinsberg, 20.07.2021



Detlef von der Lieck, Managing Director

Trotec GmbH

Grebbener Str. 7
D-52525 Heinsberg

☎ +49 2452 962-400

☎ +49 2452 962-200

✉ info@trotec.com

www.trotec.com