

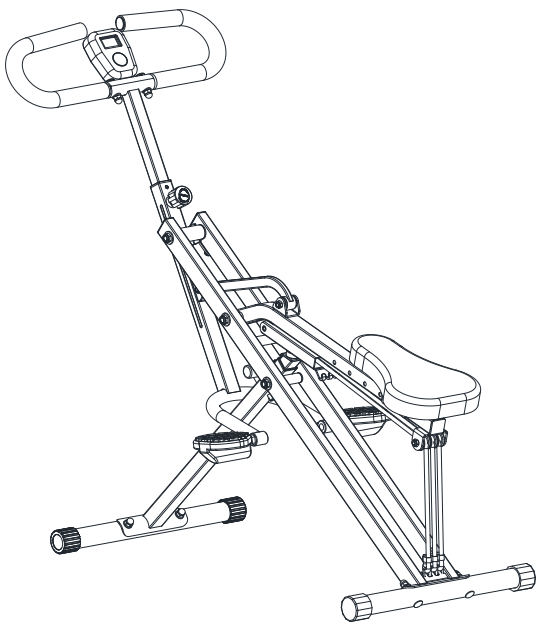

User Manual



Smart Upright Row-N-Ride Exerciser in Green

NO. 077GR

EN

IMPORTANT! Please retain owner's manual for maintenance and adjustment instructions. Your satisfaction is very important to us, **PLEASE DO NOT RETURN UNTIL YOU HAVE CONTACTED US.**

Important Safety Information

We thank you for choosing our product. To ensure your safety and health, please use this equipment correctly. It is important to read this entire manual before assembling and using the equipment. Safe and effective use can only be achieved if the equipment is assembled, maintained, and used properly. It is your responsibility to ensure that all users of the equipment are informed of all warnings and precautions.

1. Before starting any exercise program, you should consult your physician to determine if you have any medical or physical condition that could put your health and safety at risk or prevent you from using the equipment properly. Your physician's advice is essential if you are taking medication that affects your heart rate, blood pressure or cholesterol level.
2. Be aware of your body's signals. Incorrect or excessive exercise can damage your health. Stop exercising if you experience any of the following symptoms: pain, tightness in your chest, irregular heartbeat, shortness of breath, lightheadedness, dizziness, or feelings of nausea. If you do experience any of these conditions, you should consult your physician before continuing with your exercise program.
3. Keep children and pets away from the equipment. The equipment is designed for adult use only.
4. Use the equipment on a solid, flat level surface with a protective cover for your floor or carpet. To ensure safety, the equipment should have at least 2 feet (60 cm) of free space all around it.
5. Ensure that all nuts and bolts are securely tightened before using the equipment. The safety of the equipment can only be maintained if it is regularly examined for damage and/or wear and tear.
6. Always use the equipment as indicated. If you find any defective components while assembling or checking the equipment, or if you hear any unusual noises coming from the equipment during exercise, discontinue use of the equipment immediately and do not use until the problem has been rectified.
7. Wear suitable clothing while using the equipment. Avoid wearing loose clothing that may become entangled in the equipment.
8. Do not place fingers or objects into the moving parts of the equipment.
9. The maximum weight capacity of this unit is 330 lbs (150 kg).
10. The equipment is not suitable for therapeutic use.
11. To avoid bodily injury and/or damage to the product or property, proper lifting and moving are required.
12. Your product is intended for use in cool and dry conditions. You should avoid storage in extremely cold, hot or damp areas as this may lead to corrosion and other related problems.
13. This equipment is designed for indoor and home use only; it is not intended for commercial use.

Product features are subject to change. Please refer to the official specifications on www.SunnyHealthFitness.com for the most up-to-date information.

Statement of Purpose

The Smart Upright ROW-N-Ride Exerciser in Green simulates the motion of rowing, combining cardio and strength training through a dynamic, full-body workout.

Waste Disposal



SUNNY HEALTH & FITNESS products are recyclable. At the end of its useful life please dispose of this article correctly and safely (local refuse sites).

EU Declaration Of Conformity

You can find the declaration of conformity at the following link:
<https://sunnyhealthfitness.com/pages/declaration-of-conformity>

Technical Data

Connectivity: Bluetooth LE
Frequency Range: 2400~2483.5Mhz
Transmitting Power: 0dBm

Pre-Assembly Check List

When you open the carton, you will find the following parts:

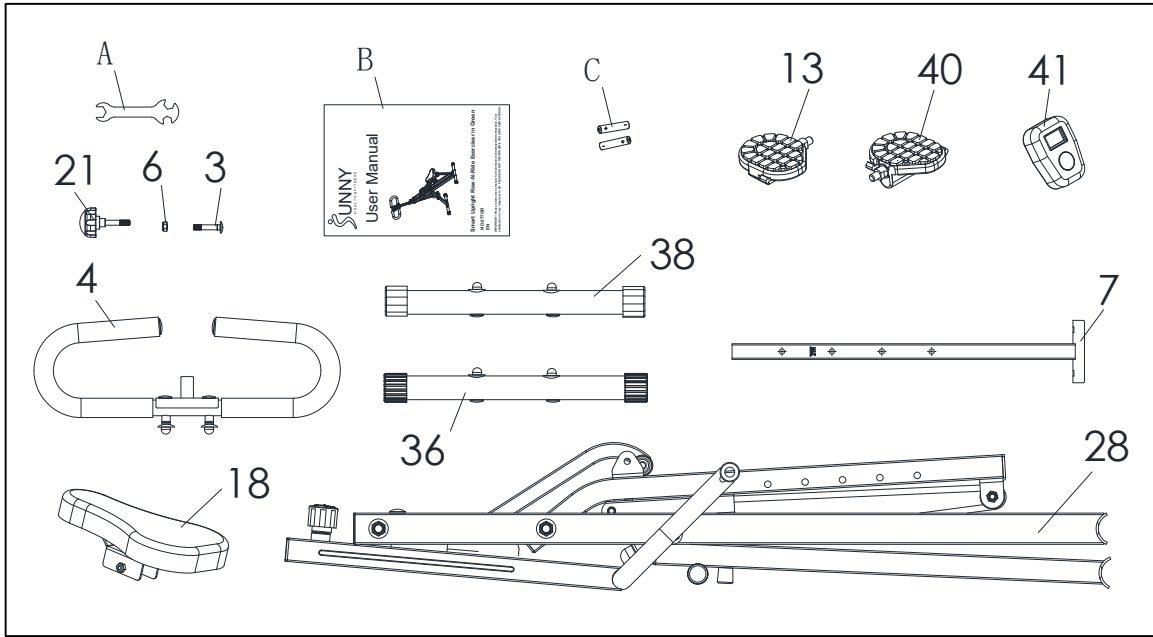

No.	Description	Spec.	Qty.
3	Bolt	M8*40.5	1
4	Handlebar		1
6	Nut	M8*13	1
7	Handlebar Tube		1
13	Left Pedal		1
18	Seat		1
21	Knob	Φ47*40*M8	1
28	Main Frame		1

No.	Description	Spec.	Qty.
36	Front Stabilizer		1
38	Rear Stabilizer		1
40	Right Pedal		1
41	Meter	DSC03601N-APP	1
A	Spanner	S13, S15, S17	1
B	Manual		1
C	Battery	AA	2

Hardware Package

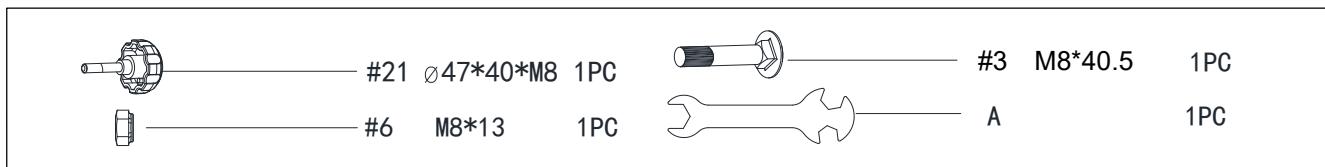

Please provide the following information in order for us to accurately identify the part(s) needed:

- ✓ The model number
- ✓ The product name
- ✓ The part number

Please contact us at support@sunnyhealthfitness.com or 1-877-90SUNNY (877-907-8669).

Warning Labels

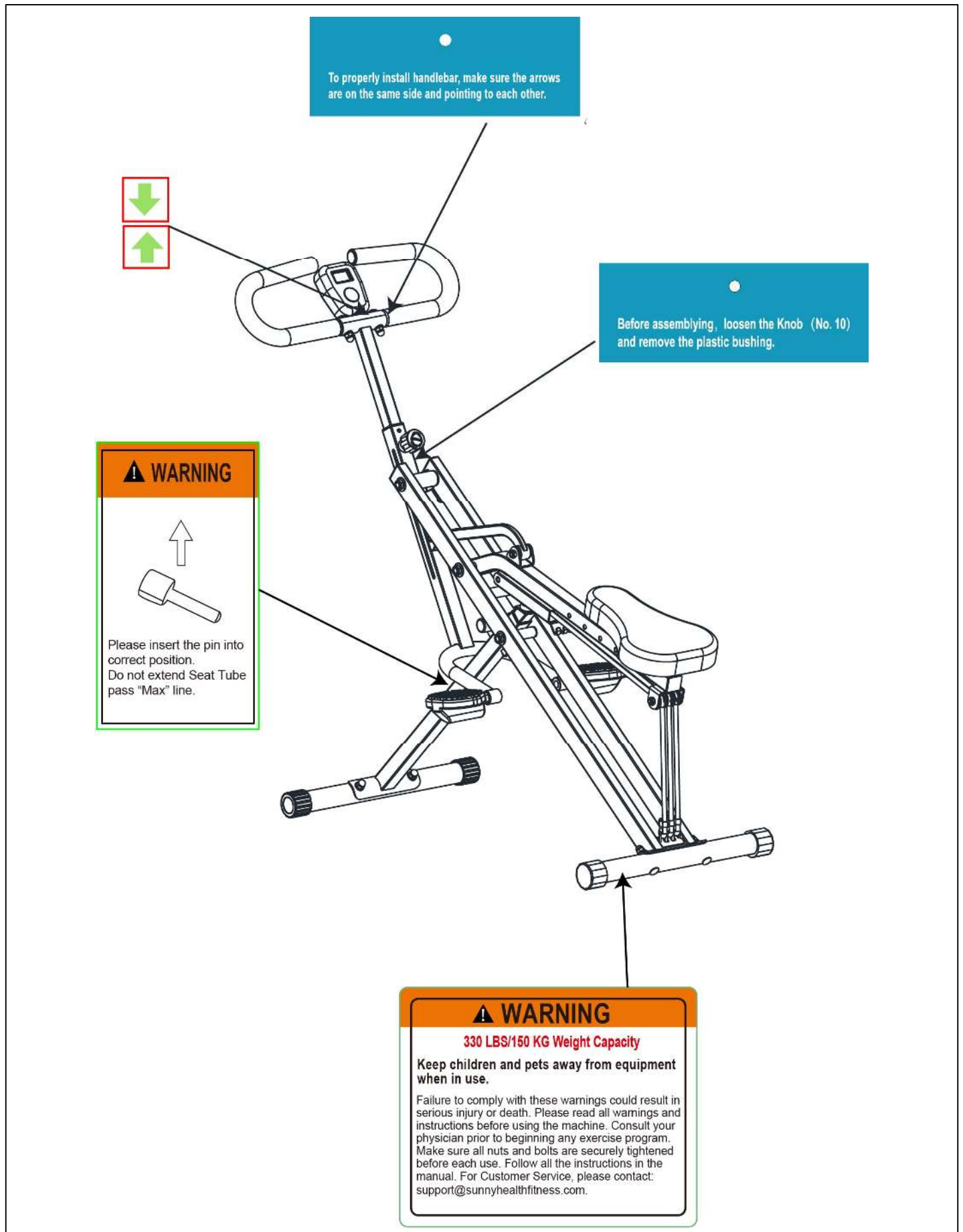

Assembly Instructions

We value your experience using Sunny Health and Fitness products. For assistance with parts or troubleshooting, please contact us at support@sunnyhealthfitness.com or 1-877-90SUNNY (877-907-8669).

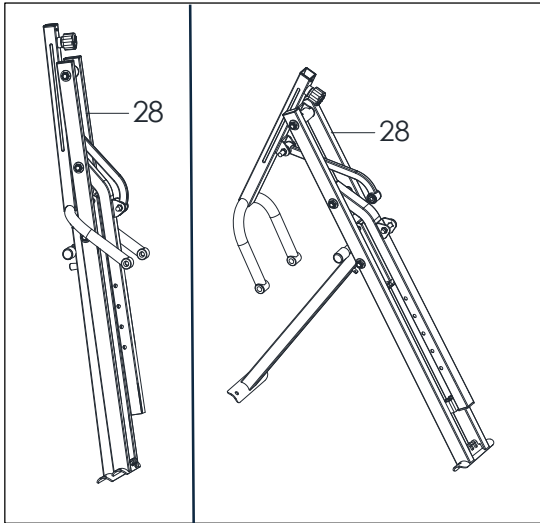

STEP 1:

Open the **Main Frame (No. 28)** as shown in the picture on the left.

NOTE: The **Pin (No. 29)** has been inserted into **Front Connecting Tube (No. 32)**.

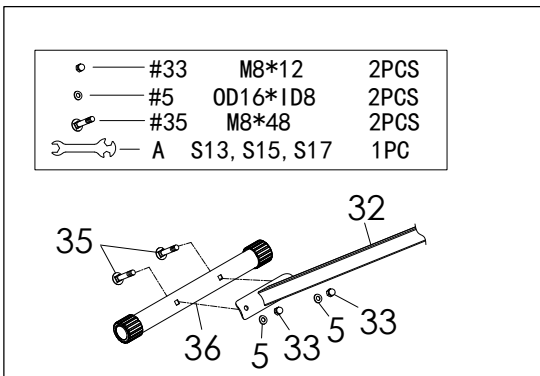
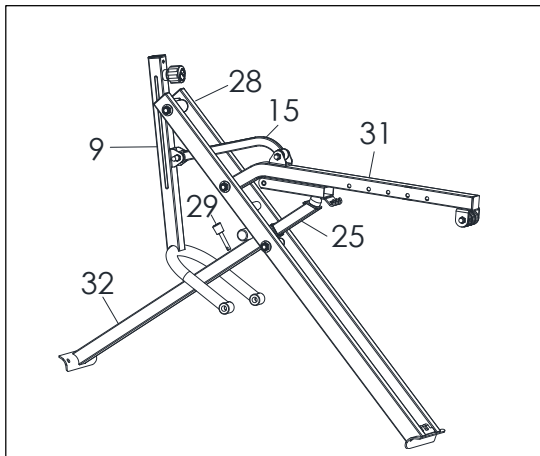

STEP 2:

Remove 4 **Bolts (No. 35)**, 4 **Nuts (No. 33)** and 4 **Washers (No. 5)** from the **Front & Rear Stabilizers (No. 36 & No. 38)** with **Spanner (No. A)**.

Attach **Front Stabilizer (No. 36)** to **Front Connecting Tube (No. 32)** using 2 **Bolts (No. 35)**, 2 **Nuts (No. 33)** and 2 **Washers (No. 5)** that were removed. Tighten and secure with **Spanner (No. A)**.

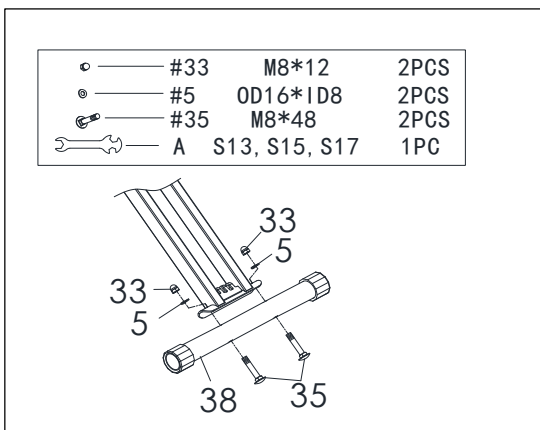

Attach **Rear Stabilizer (No. 38)** to **Main Frame (No. 28)** using 2 **Bolts (No. 35)**, 2 **Nuts (No. 33)** and 2 **Washers (No. 5)** that were removed. Tighten and secure with **Spanner (No. A)**.

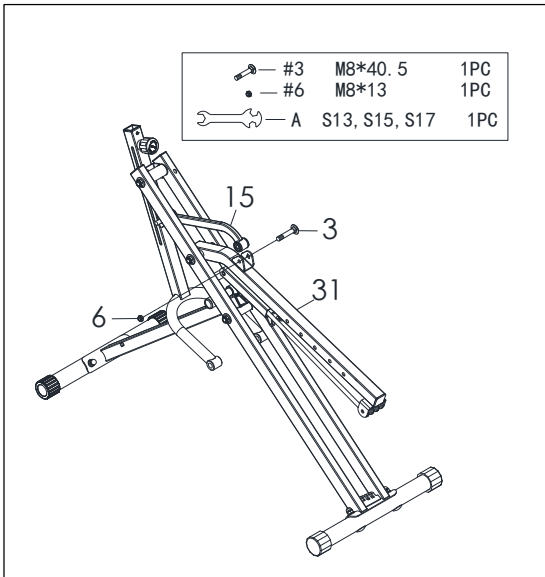

STEP 3:

Insert the **Connecting Tube (No. 15)** into the metal bracket slot of **Seat Connecting Tube (No. 31)**. Then insert **Bolt (No. 3)** into **Seat Connecting Tube (No. 31)** and secure **Nut (No. 6)** using **Spanner (No. A)**.

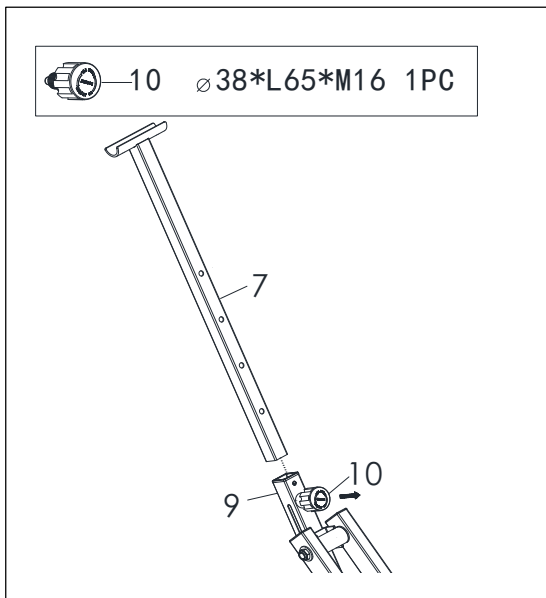

STEP 4:

Loosen and pull out the **Knob (No. 10)** from the **Pedal Connecting Tube (No. 9)**, insert **Handlebar Tube (No. 7)** into **Pedal Connecting Tube (No. 9)**. Then insert and secure with **Knob (No. 10)** after adjusting to proper height.

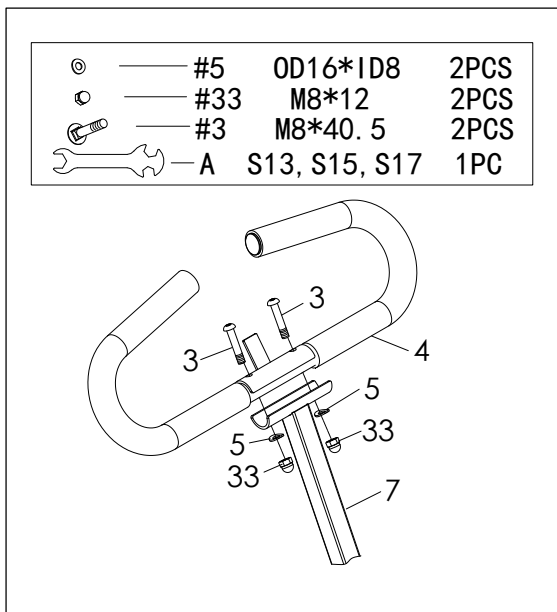

STEP 5:

Remove preassembled 2 **Bolts (No. 3)**, 2 **Washers (No. 5)** and 2 **Nuts (No. 33)** from the **Handlebar (No. 4)** and attach the **Handlebar (No. 4)** to the **Handlebar Tube (No. 7)** using 2 **Bolts (No. 3)**, 2 **Washers (No. 5)** and 2 **Nuts (No. 33)** that were removed and secure with **Spanner (No. A)**.

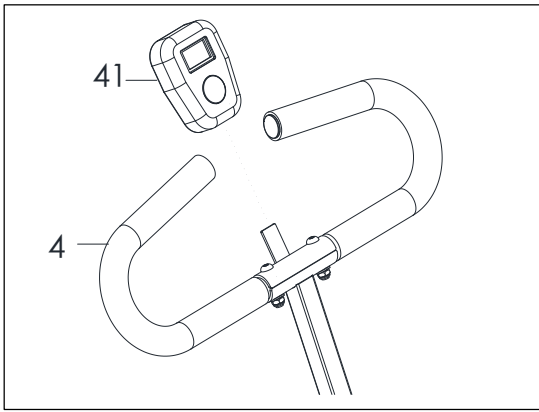

STEP 6:

Insert the **Meter (No. 41)** onto the tab on the **Handlebar (No. 4)**.

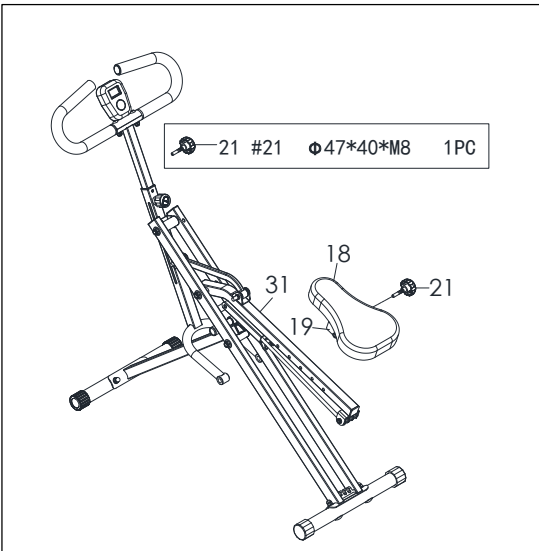

STEP 7:

Attach the **Fixed Iron Sheet (No. 19)** to the **Seat Connecting Tube (No. 31)**, adjust the **Seat (No. 18)** to your desired position, then tighten and secure with the **Knob (No. 21)**.

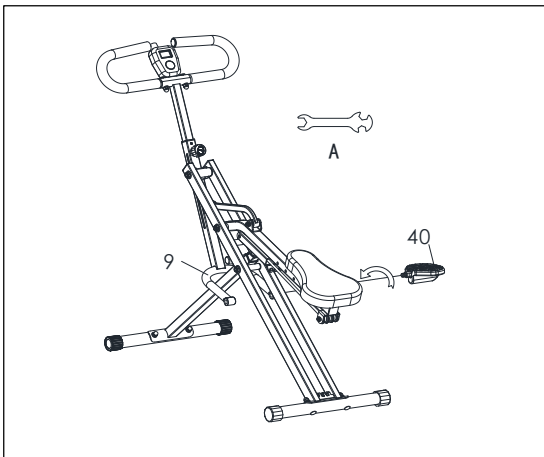

STEP 8:

Attach the **Left & Right Pedals (No. 13 & No. 40)** to the **Pedal Connecting Tube (No. 9)** and tighten **Left & Right Pedals (No. 13 & No. 40)** *clockwise* with **Spanner (No. A)**.

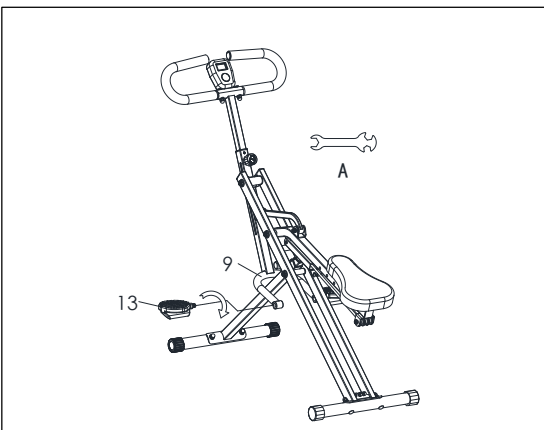

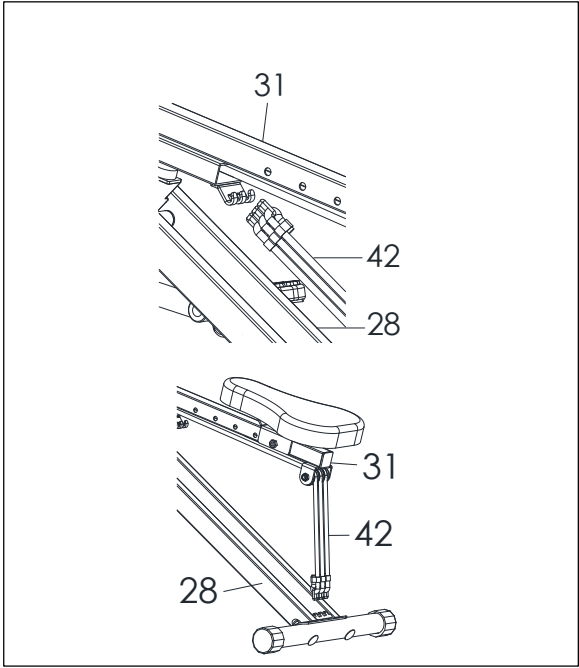

STEP 9:

Unhook Resistance Bands (No. 42) from the Seat Connecting Tube (No. 31), and connect the Resistance Bands (No. 42) to the hooks on the Main Frame (No. 28).

The assembly is complete!

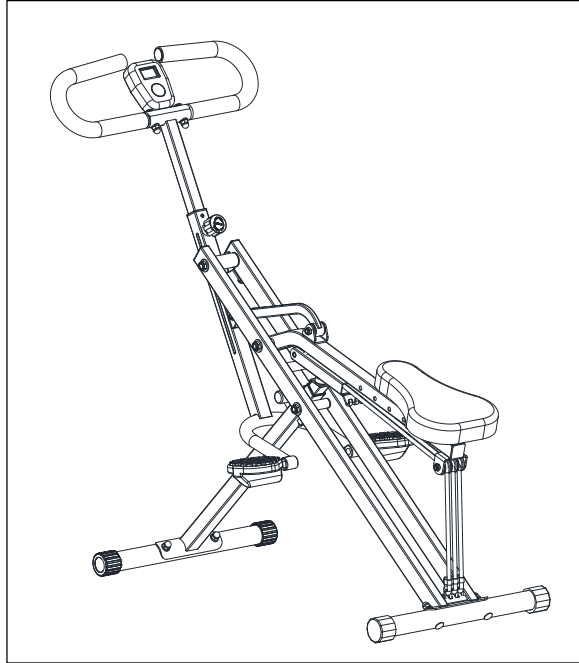

Adjustment Instructions

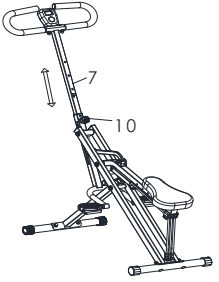
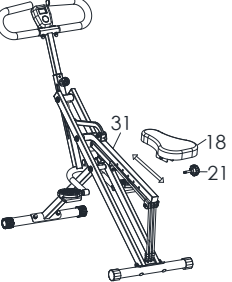
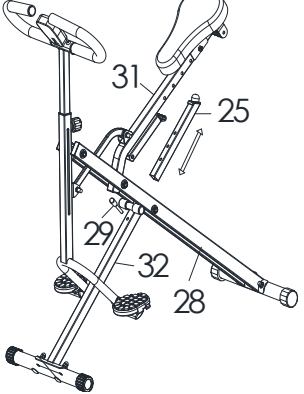
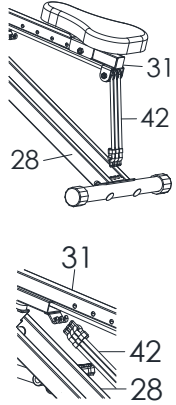
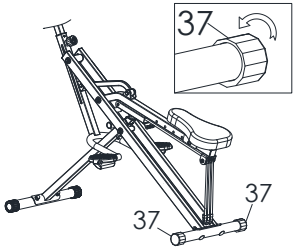
	<p>ADJUSTING THE HANDLEBAR</p> <p>Loosen the Knob (No. 10) and pull. Raise or lower the Handlebar Tube (No. 7) to desired height. Tighten the Knob (No. 10).</p>
	<p>ADJUSTING THE SEAT</p> <p>Loosen and remove the Knob (No. 21) located under the Seat Connecting Tube (No. 31). Move the Seat (No. 18) to desired position, then re-tighten the Knob (No. 21).</p>
	<p>ADJUSTING THE SEAT TUBE</p> <p>To adjust the Seat Tube (No. 25), lift the Seat Connecting Tube (No. 31). Remove the Pin (No. 29) from Front Connecting Tube (No. 32) and raise or lower the Seat Tube (No. 25) to desired position. Re-insert the Pin (No. 29) to secure. Then lower the Seat Connecting Tube (No. 31). Raising or lowering Seat Tube (No. 25) will change the difficulty of your exercise.</p> <p>NOTE: Make sure Resistance Bands (No. 42) are not hooked to Main Frame (No. 28) when adjusting the Seat Tube (No. 25). Do not extend the Seat Tube (No. 25) to pass “MAX” line.</p>
	<p>ADJUSTING THE EXERCISE BAND</p> <p>You can adjust the difficulty of your exercise by adjusting the Resistance Bands (No. 42). To reduce difficulty, unhook Resistance Bands (No. 42) from the Main Frame (No. 28) and connect the Resistance Bands (No. 42) to the hooks on the Seat Connecting Tube (No. 31).</p>
	<p>ADJUSTING THE BALANCE</p> <p>In order to achieve a smooth and comfortable ride, you must ensure that the bike is stabled and secured. If you notice that the bike is unbalanced during use, you should adjust the End Caps (No. 37) located on the rear stabilizer until the bike becomes levelled with the floor surface.</p>

Folding Instructions

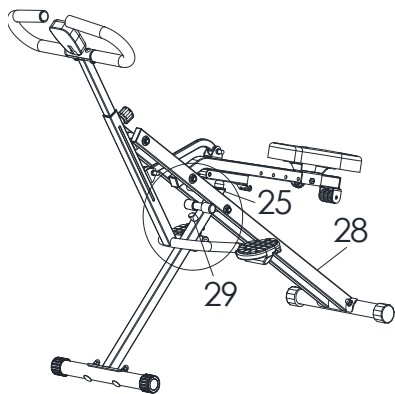

A. Adjust the **Seat Tube (No. 25)** to the lowest level by the **Pin (No. 29)**.

NOTE: Make sure **Resistance Bands (No. 42)** are not connected to **Main Frame (No. 28)** when folding.

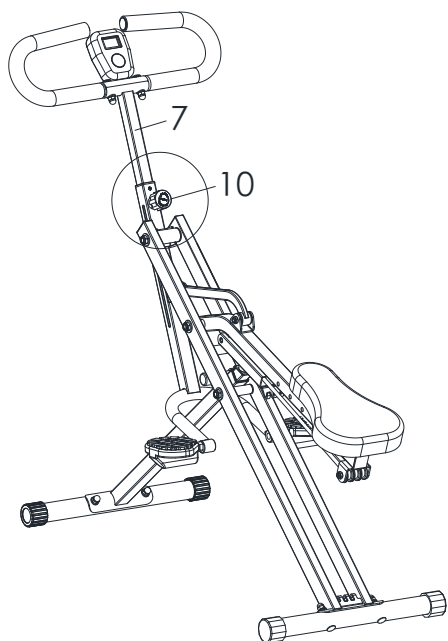

B. Adjust the **Handlebar Tube (No. 7)** to the lowest level by **Knob (No. 10)**.

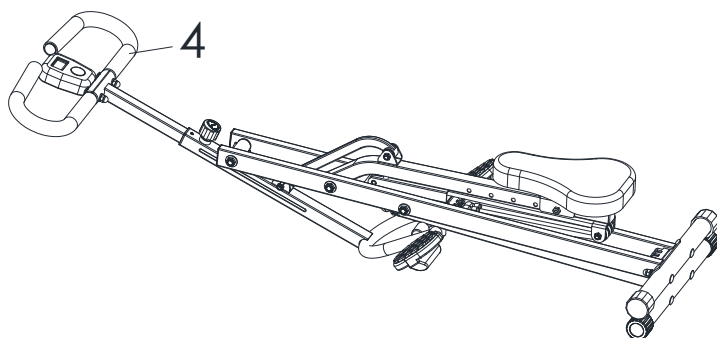

C. Hold the **Handlebar (No. 4)** and fold the product.

Battery Installation & Replacement

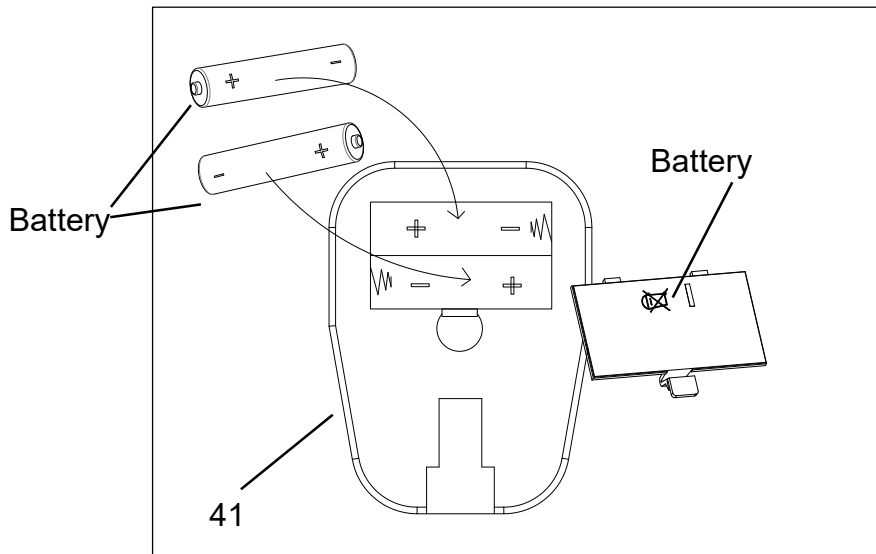

BATTERY INSTALLATION:

1. Take out 2 AA batteries from manual bag.
2. Press the buckle of battery cover on the **Meter (No. 41)**, then remove battery cover.
3. Install 2 AA batteries into the battery case on the back of the **Meter (No. 41)**. Pay attention to the battery + and - poles before installing.
4. Press the buckle of battery cover, then put the battery cover back to the back of the **Meter (No. 41)**.

The installation is complete!

BATTERY REPLACEMENT:

1. Press the buckle of battery cover on the back of the **Meter (No. 41)**, then remove battery cover.
2. Remove the 2 old AA batteries in the battery case and install 2 new AA batteries into the battery case on the back of the **Meter (No. 41)**. Pay attention to the battery + and - poles before installing.
3. Press the buckle of battery cover, then put the battery cover back to the back of the **Meter (No. 41)**.

The replacement is complete!

NOTE: Always change both batteries at the same time. Do not mix battery types and do not mix old and new batteries. Dispose battery according to your state and regional guidelines.

Exercise Meter

SPECIFICATIONS:

TIME.....00:00-99:59 MIN/SEC.
CNT (COUNT).....0-9999 STROKES
CAL (CALORIES).....0-999.9 KCAL
TOTAL (TOTAL COUNT).....0-9999 K
PULSE.....40-240BPM

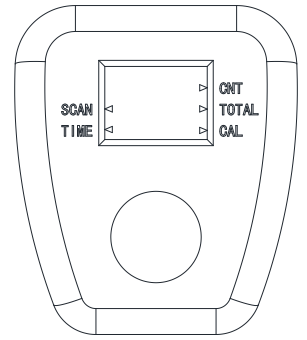

FUNCTIONS:

TIME: Displays the workout time while exercising.

CNT (COUNT): Accumulate the strokes while exercising.

CAL (CALORIES): Displays calories amount burned while exercising.

TOTAL (TOTAL COUNT): Displays the total number of strokes since batteries installed.

When reach 10,000~99,999 steps: meter will only display 10.00K~99.99K

When reach 100,000~999,999 steps: meter will display 100.0K~999.9K

When reach 1,000,000~9,999,999 steps: meter will display 1000K~9999K

PULSE: Displays current heart rate value. The data comes from the matching Bluetooth heart rate monitor.

SCAN: Automatically scan through each function between ①TIME ②CAL (CALORIES) ③TOTAL (TOTAL COUNT) ④PULSE.

BLUETOOTH :

1. The Bluetooth icon will flash when the meter is on or wakes from sleep mode. If no Bluetooth connection is established within 3 minutes, the Bluetooth icon will turn off.
2. The Bluetooth icon will stay on when it is connected.

WIRELESS HEART RATE :

1. The wireless heart rate icon will flash when the meter is on. If the heart rate monitor is not connected within 1 minute, the wireless heart rate icon will turn off.
2. After exercise resumes, the wireless heart rate icon will flash. If the heart rate monitor is not connected within 1 minute, the wireless heart rate icon will turn off.
3. When the meter wakes from sleep mode, the wireless heart rate icon will flash. If the heart rate monitor is not connected within 1 minute, the wireless heart rate icon will turn off.
4. The wireless heart rate icon will flash when the MODE key is pressed. If the heart rate monitor is not connected within 1 minute, the wireless heart rate icon will turn off.
5. The wireless heart rate icon will stay on when the heart rate monitor is connected.

NOTE: The heart rate monitor is not included. Wireless heart rate function works with SunnyFit Heart Rate Monitor HR200. HR200 can only connect to the meter when the wireless heart rate icon is flashing.

KEY FUNCTION:

MODE: Press to select the function you want. Hold the MODE key for 2 seconds to reset all values except TOT when the Bluetooth is not connected.

Press and hold the MODE key for 6 seconds to disconnect from both the SunnyFit APP and the heart rate monitor; then, the meter will enter sleep mode.

OPERATION PROCEDURES:

AUTO ON/OFF: The meter will turn on when exercise starts or when **MODE** is pressed.

The meter will shut off automatically and disconnect the heart rate monitor if there is no activity for 4 minutes when the Bluetooth is not connected.

APP Connection:

Connect Smart Equipment to SunnyFit App:

1. Scan to download SunnyFit from the app store:



2. Ensure that the Bluetooth function is turned on from your mobile device.
3. If this is your first time using the SunnyFit app, follow the in-app instructions to register for your free SunnyFit account and log in.
4. Begin any workout activity that matches your smart equipment, then follow the onscreen prompts to search for and connect to your smart equipment.
5. When connected, your stats and records will be displayed at the end of your course/session, and recorded in your account profile!

Troubleshooting:

- If you are having trouble connecting your smart equipment, visit www.sunnyfit.com/guide or scan the QR code below:



- If you require additional support, please contact support@sunnyfit.com

Parts List

No.	Description	Spec.	Qty.
1	Sponge	Φ29	2
2	Plug	Φ25*1.5	2
3	Bolt	M8*40.5	4
4	Handlebar		1
5	Washer	OD16*ID8	6
6	Nut	M8*13	3
7	Handlebar Tube		1
8	Bushing	30*30*T1.5	2
9	Pedal Connecting Tube		1
10	Knob	Ø38*L65*M16	1
11	Bearing Sleeve	Φ28*13	2
12	Hexagon Screw	M8*50	1
13	Left Pedal		1
14	Bearing Sleeve	Φ25*11	4
15	Connecting Tube		1
16	Bearing Sleeve	Φ19*12	4
17	Plug	30*30*1.5	1
18	Seat		1
19	Fixed Iron Sheet		1
20	Screw	M6	2
21	Knob	Φ47*40*M8	1
22	Plug	40*20*1.5	2
23	Bolt	M10	3

No.	Description	Spec.	Qty.
24	Stopper	Φ34	1
25	Seat Tube		1
26	Washer	OD20*ID11	6
27	Nut	M10	3
28	Main Frame		1
29	Pin	Φ8*42.5	1
30	Plug	Φ19*35	2
31	Seat Connecting Tube		1
32	Front Connecting Tube		1
33	Nut	M8*12	6
34	Cap	Φ46*36	2
35	Bolt	M8*48	4
36	Front Stabilizer		1
37	End Cap	Φ38*35	2
38	Rear Stabilizer		1
39	Square Buckle	Φ3.2	3
40	Right Pedal		1
41	Meter	DSC03601N-APP	1
42	Resistance Band	Φ8*710	3
43	Bolt	M8*65	1
44	Plastic Wheel		3
A	Spanner	S13, S15, S17	1

Exploded Diagram

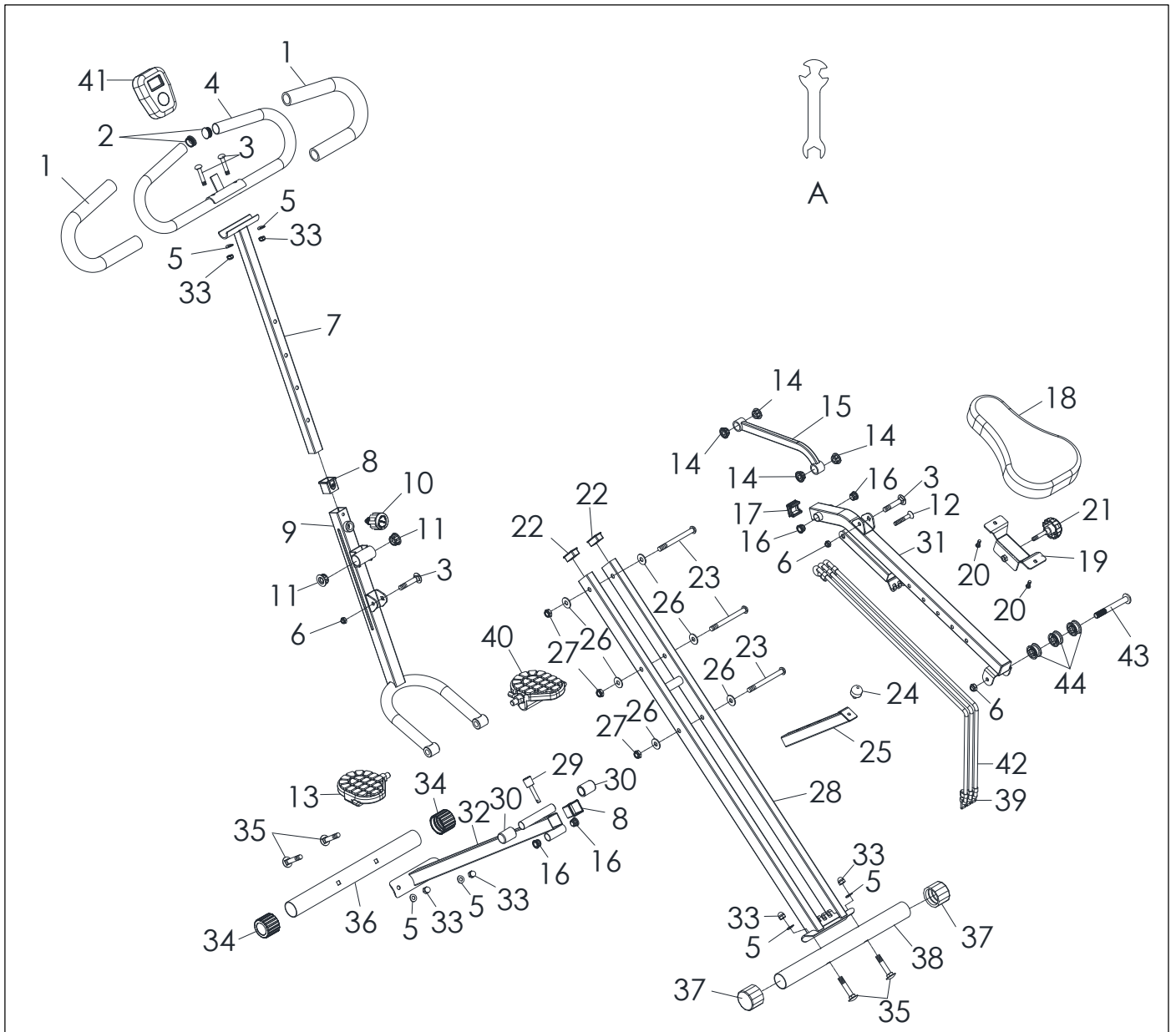

Version: 1.2

Register

Register your product and verify warranty terms:

Sunnyhealthfitness.com/warranty



Download

Track your fitness progress & join **FREE** workout courses!

Download SunnyFit App today!



Follow

Find us on social media



Contact

Get in touch with us for any questions



1-877-90SUNNY (877-907-8669)



support@sunnyhealthfitness.com