



BROADWAY

Billboard Lights

10W 20W

Installation Manual

SOLTECH Designs and Manufactures
Advanced, Solar-Powered
LED Technology.



SOLTECH

Smart Solar Lighting

01 Introduction

Thank you for purchasing BROADWAY Urban Lighting Products.

Important

Please read these instructions before installation to ensure optimum results and longevity of your lights. The solar panel should be charged in full sunlight for 8 to 9 hours before initial first use to provide optimum results.

Features

- Easy Installation—No electrical wiring is required with its integrated design
- Turns on automatically at night and off during the day
- The lights include an ON / OFF switch and built in battery
- Battery can support 2-3 nights with cloudy days once fully charged
- Intelligent power saving mode increases lighting x1.5 times
- IP65 water and dust resistance

How The Solar Panel Works

During the day, the solar panel converts sunlight into electricity to charge the battery. At night, the lights turn ON automatically using the electricity stored in the battery. The performance of the solar light depends on the location of the solar panel and weather conditions. Install the solar panel in a sunny location to ensure it receives 6–8 hours of sunlight each day. Reduced sunlight will reduce continuous working hours at night.

Please Note

During continuous rainy or cloudy days, run time may be reduced as the battery will not be fully charged.

BROADWAY 10W

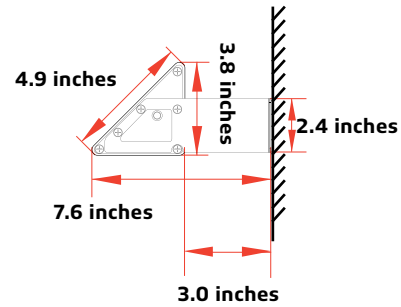
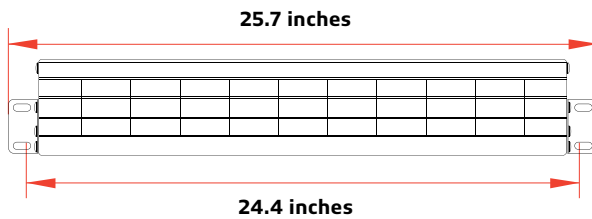

BROADWAY 20W

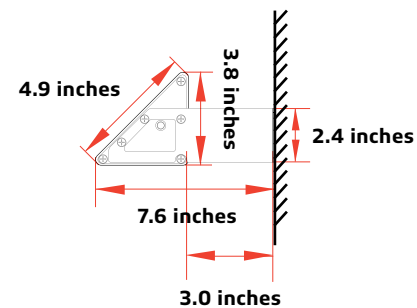
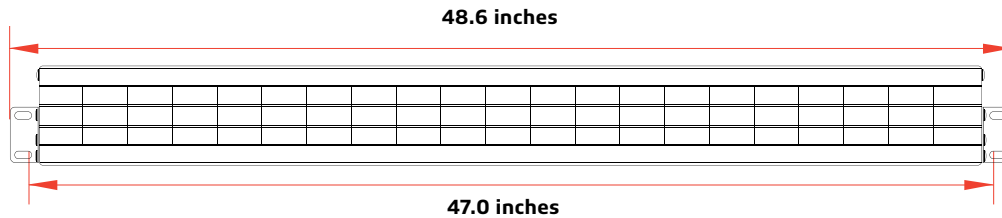

02 Specification

Specifications	BROADWAY 10W	BROADWAY 20W
LED Nominal Power	10W	20W
Solar Panel	5.5V 8W polycrystalline	5.5V 17W polycrystalline
Lithium Ion Battery	3.7V 17.6AH	3.7V 35.2AH
CCT	4,000K, 5,000K	4,000K, 5,000K
Lumen Output@5000K	1,000	2,000
CRI	> 70	> 70
LED Chip	OSRAM	OSRAM
EPA	1.05	2.1
Beam Angle	120°	120°
Waterproof Rate	IP65	IP65
Casting	PC & Aluminum	PC & Aluminum
Efficiency@5000K	100 lm/W	100 lm/W
* Charging Time	8-10 hrs (1000W/m ²)	8-10 hrs (1000W/m ²)
Run Time (@Full Power)	2-3 Days	2-3 Days
Operation Mode	First 4 hours 100% brightness, 25% brightness till dawn	First 4 hours 100% brightness, 25% brightness till dawn
* Operating Temperature	-20°C/-4°F to 149°F	-20°C/-4°F to 149°F
* Charging Temperature	0°C/32°F to 113°F	0°C/32°F to 113°F

* The temperature can impact the battery's charging and normal operation.

* The solar charge time data is base on 77 degree F ambient temperature with the panel pointed directly at the solar radiation. The standard radiation value is 1000W/m².

03 Installation

Wall Mount

01

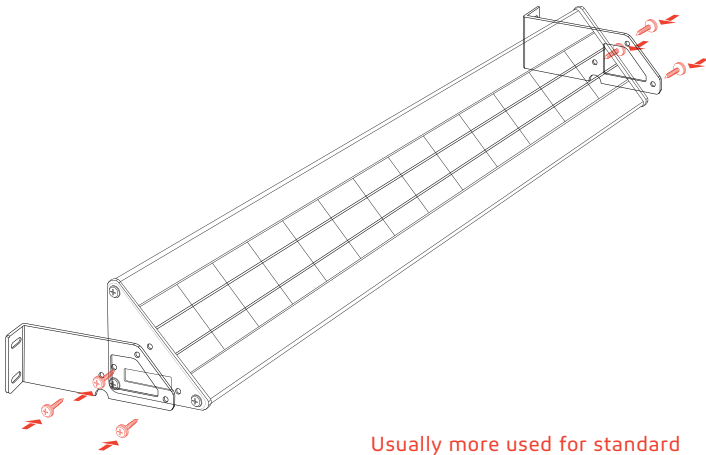

Usually more used for standard Billboards alongside express ways, the Triangle Mount is versatile and can be installed in more traditional signage, this can also be used for commercial establishments and buildings.

02

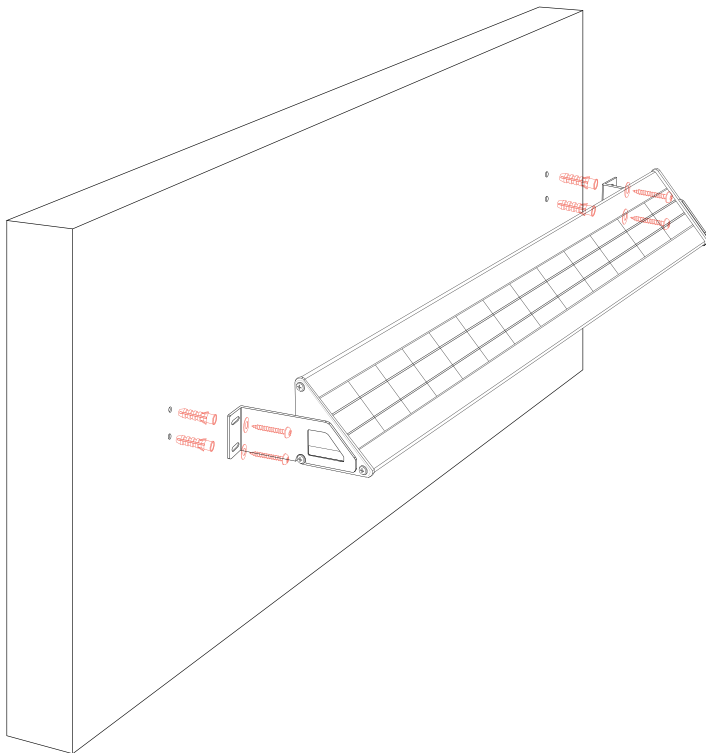

01

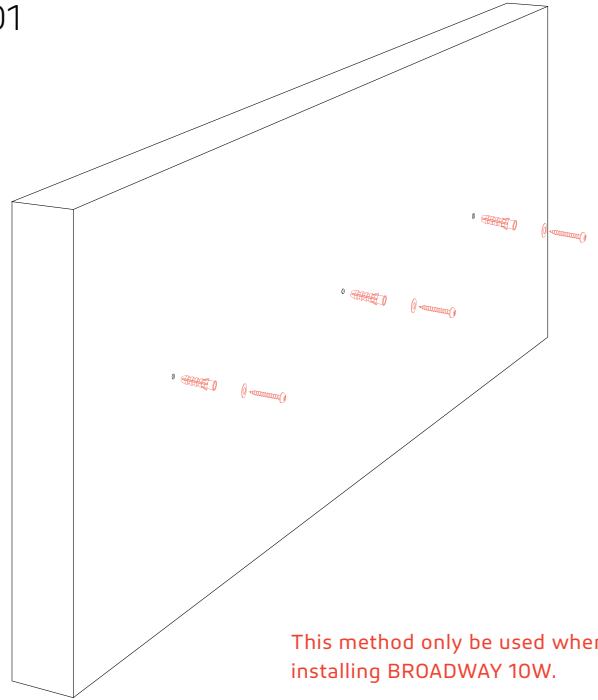

This method only be used when installing BROADWAY 10W.

02

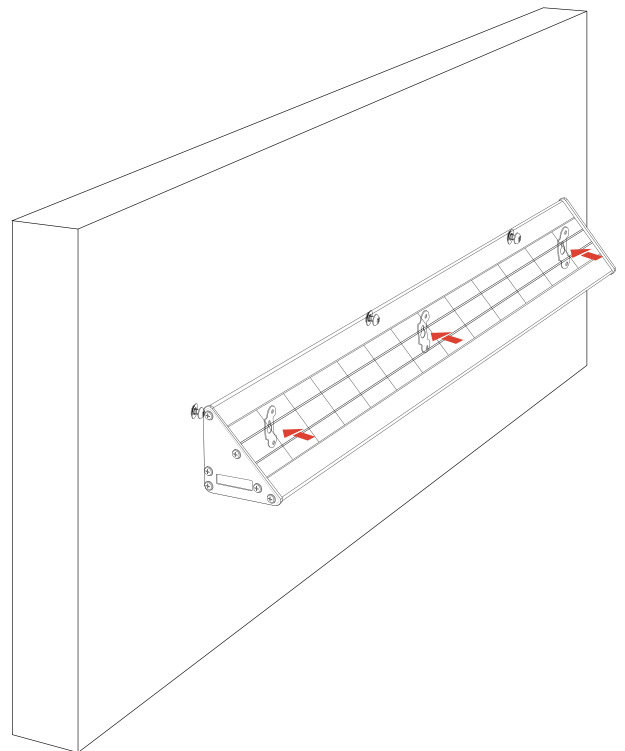

Long Arm Mount

01

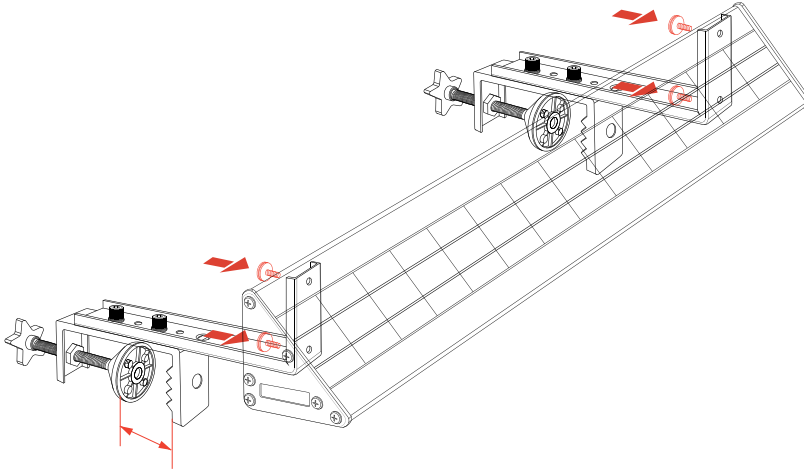

Maximum 2.5 inches

02

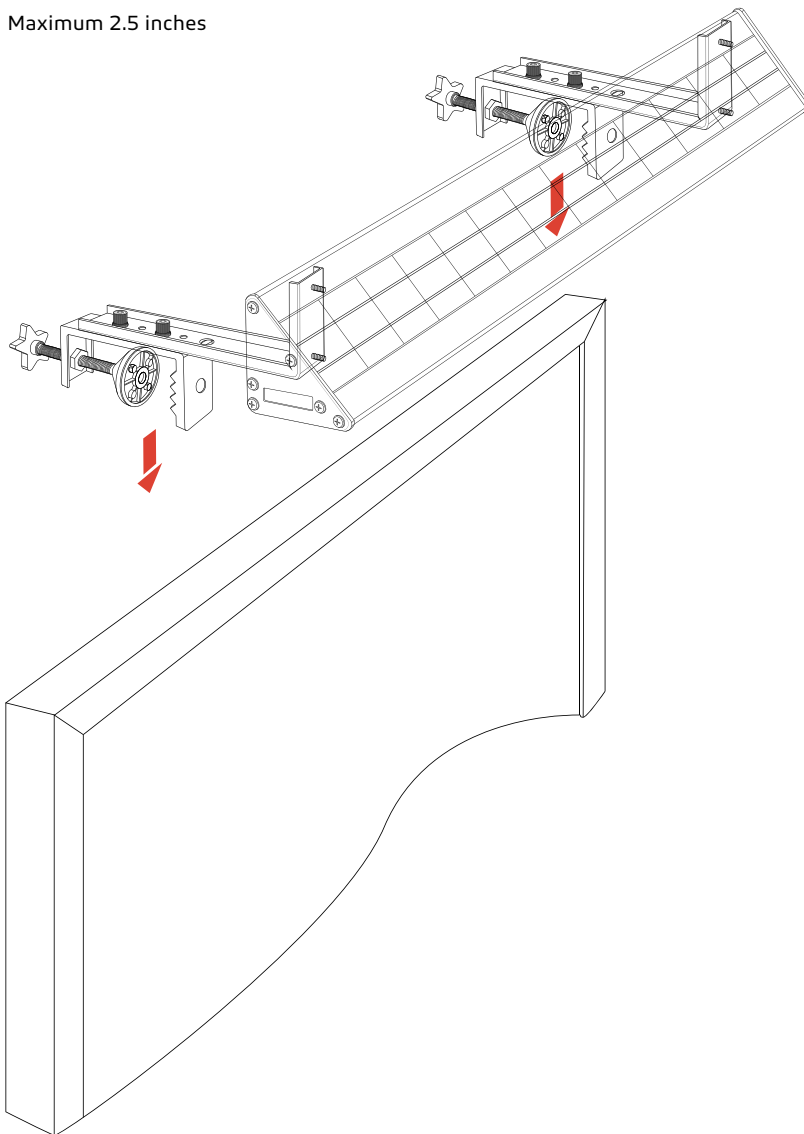

BROADWAY 10W needs two Long Arm Mounts. If you install BROADWAY 20W, you need three Long Arm Mounts.

Long Arm Mount accessories not included in standard packaging. Please advise your SOLTECH sales representative if needed.

For thinner billboards, the Long Arm mount uses a tighten-to-grip system that securely places the Broadway into place. Perfect for temporary signs that need illumination for a shorter period of time.

04 Luminous Distribution

BROADWAY 10W [MOUNTING HEIGH: 20FT]

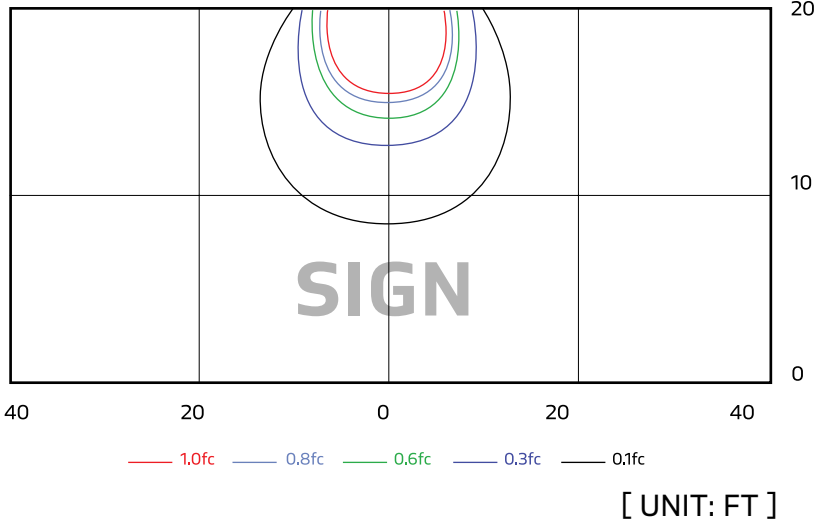

BROADWAY 20W [MOUNTING HEIGH: 20FT]

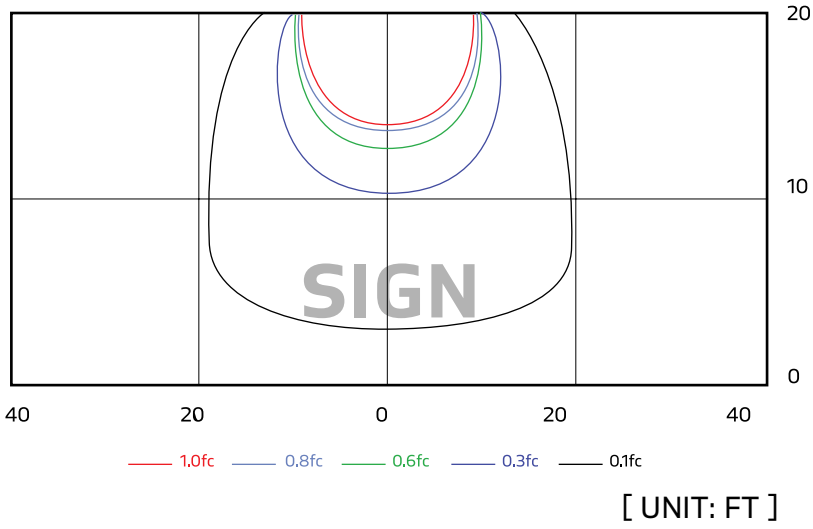

05 Warranty

BROADWAY is covered by a 3 year limited warranty. SOLTECH urban light warrants to the original purchaser that this product is free from defects in materials and workmanship for the period of 3 years from date of purchase. To obtain warranty service please contact your local distributor or sales rep for further instruction.

**SOLTECH Designs
and Manufactures
Advanced,
Solar-Powered
LED Technology.**



1460 Park Avenue.
Emeryville, CA 94608 USA
www.soltechlighting.com

SOLTECH LLC reserves the right to update all product data sheets at any time. Consult SOLTECH marketing specialists for publication updates at hello@soltechlighting.com

*Copyright©2018-2024 SOLTECH LLC,
All Rights Reserved.*