



## **EN ■ Cordless Vacuum Cleaner 4in1**

*Translation of the original manual*

**READ CAREFULLY AND STORE FOR FUTURE USE.**

- This vacuum cleaner may be used by children 8 years of age and older and by persons with physical or mental impairments or by inexperienced persons, if they are properly supervised or have been informed about how to use this vacuum cleaner in a safe manner and understand the potential dangers. Children must not play with the vacuum cleaner. Cleaning and maintenance performed by the user must not be performed by unsupervised children. Keep the vacuum cleaner and its accessories out of reach of children that are younger than 8 years of age.
- This vacuum cleaner is designed for use in households, offices and similar types of areas. Do not use it in industrial surroundings or outdoors.
- Do not expose the vacuum cleaner to direct sunlight and do not place it near an open fire or appliances that are a source of heat.
- Only use the vacuum cleaner with the original power adapter, charging base and accessories that were supplied with it.
- Before connecting the adapter to a power socket, check that the technical details on its rating label match the electrical voltage in the power socket.

- Make sure the adapter power cord is not touching a hot surface or sharp objects. Position the adapter power cord so that it will not be tripped over.
- Never submerge the vacuum cleaner, the charging base and the power adapter in water or any other liquid and do not wash under running water.
- Before turning on the vacuum cleaner, check that the internal and external filter is properly installed.
- When the vacuum cleaner is running, ensure that the air outlets and the suction opening are not blocked.
- Do not use the vacuum cleaner to vacuum the following items:
  - smouldering cigarettes, burning items, matches or embers;
  - water and other liquids;
  - flammable or volatile materials;
  - sharp items, e.g. broken glass, needles, pins, etc.;
  - flour, wall plaster, cement and other building materials;
  - larger pieces of paper or plastic bags, which can easily block the suction opening.
- Vacuuming of some types of floors or floor surfaces can create electrostatic discharge, which presents no danger to the user.
- Always turn off the vacuum cleaner when you have finished using it, before cleaning or placing it in the charging base.

- Disconnect the power adapter from the power socket before cleaning it and after it has finished charging.
- Disconnect the power adapter from the power socket by pulling on the plug, never pull on the power cord. Otherwise, this could damage the power adapter or the socket.
- If the power adapter is damaged, it must be replaced with an original type. For a replacement power adapter, please contact an authorised service centre.
- Do not use the vacuum cleaner if it is not working correctly, if it has been damaged or has been submerged in water. Do not repair the vacuum cleaner yourself or make any adjustments to it. Have all repairs performed at an authorised service centre. By tampering with the appliance, you risk voiding your legal rights arising from unsatisfactory performance or quality warranty.

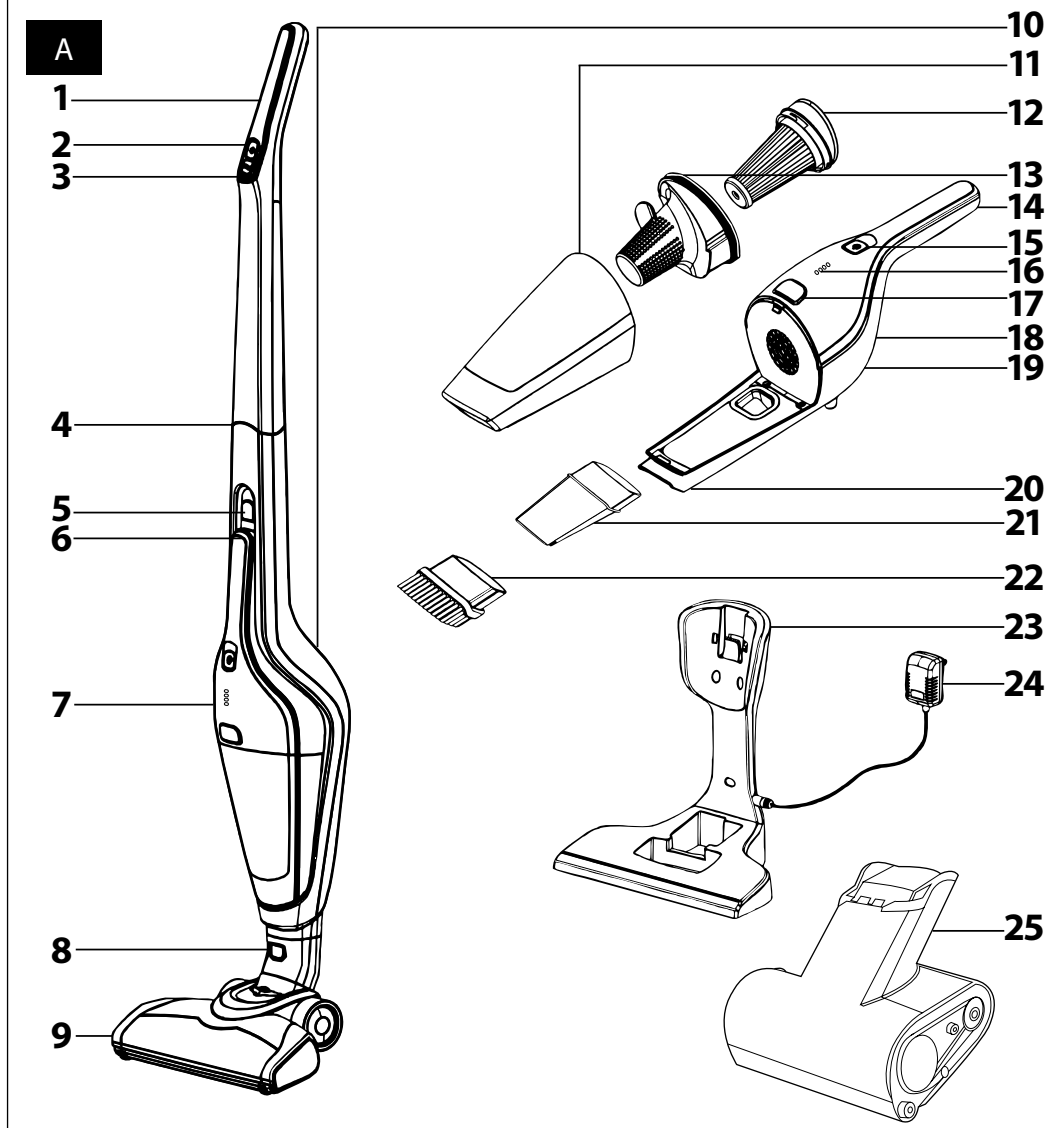

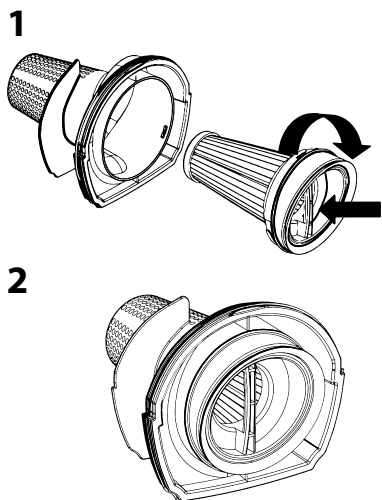
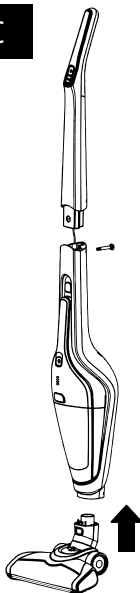
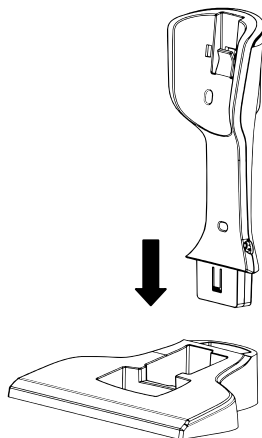
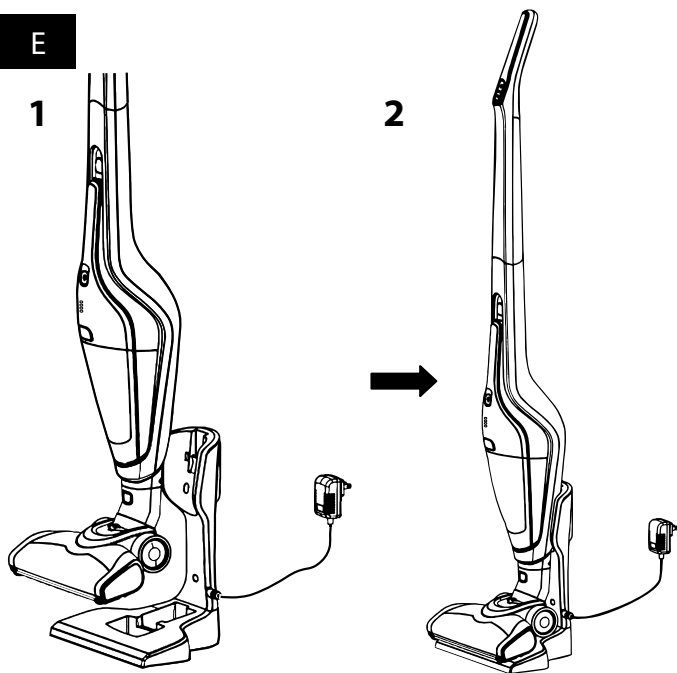
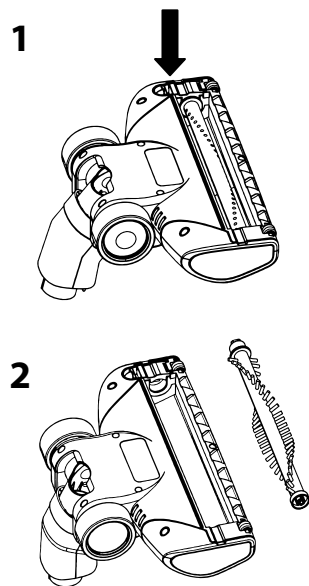
**B****C****D****E****F**

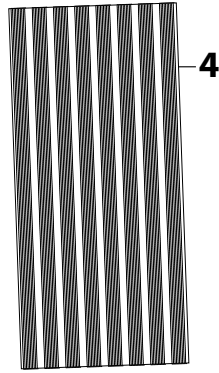
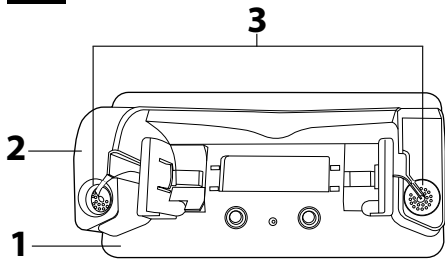
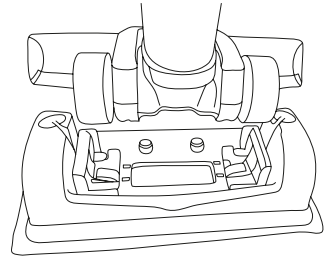
**G****H**

# EN Cordless Vacuum Cleaner 4in1

## User's manual

- Prior to using this appliance, please read the user's manual thoroughly, even in cases, when one has already familiarised themselves with previous use of similar types of appliances. Only use the appliance in the manner described in this user's manual. Keep this user's manual in a safe place where it can be easily retrieved for future use.
- We recommend saving the original cardboard box, packaging material, purchase receipt and responsibility statement of the vendor or warranty card for at least the duration of the legal liability for unsatisfactory performance or quality. In the event of transportation, we recommend that you pack the appliance in the original box from the manufacturer.

## DESCRIPTION OF THE VACUUM CLEANER AND ITS ACCESSORIES

<b>A1</b> Handle of the upright vacuum cleaner	<b>A10</b> Air exhaust openings
<b>A2</b> On/Off button of the upright vacuum cleaner	<b>A11</b> Dust container
<b>A3</b> Button for setting 2 suction power levels and 2 rotary brush speeds	<b>A12</b> Washable internal HEPA type filter
<b>A4</b> Connecting cable located in the joint between the handle and body of the upright vacuum cleaner.	<b>A13</b> Washable external filter
<b>A5</b> Button for releasing the hand vacuum cleaner from the body of the vacuum cleaner	<b>A14</b> Hand vacuum cleaner holder
<b>A6</b> Body of the vacuum cleaner	<b>A15</b> On/Off button of the hand vacuum cleaner
<b>A7</b> Bagless hand vacuum cleaner with the Cyclone system for perfect separation of dust from air	<b>A16</b> LED charging level and battery power indicators
<b>A8</b> Floor nozzle release button	<b>A17</b> Dust container release button
<b>A9</b> Floor nozzle with an electric rotary brush	<b>A18</b> Motor unit of the hand vacuum cleaner
	<b>A19</b> Air exhaust openings
	<b>A20</b> Hand vacuum cleaner suction opening
	<b>A21</b> Slot nozzle
	<b>A22</b> Brush nozzle
	<b>A23</b> Charging base with storage space for the slot nozzle and brush nozzle
	<b>A24</b> Power adapter
	<b>A25</b> Cat&Dog Mini motorised brush

## DESCRIPTION OF THE MOP ATTACHMENT

<b>G1</b> Mop attachment	shown)
<b>G2</b> Tank for water / solution with cleaning detergent	<b>G6</b> Removable panel with nozzles (at the bottom of the attachment, not shown)
<b>G3</b> Filling outlets	
<b>G4</b> Removable Velcro mop cover	
<b>G5</b> Surface to attach the mop cover (at the bottom of the attachment, not	

## ASSEMBLY AND DISASSEMBLY

### 1. Hand vacuum cleaner

- Insert the internal filter **A12** into the external filter **A13** and turn the handle of the internal filter **A12** clockwise (see fig. **B1**), until both filters are joined (see fig. **B2**). Insert the assembled filter into the dust container **A11**, and attach the dust container **A11** to the motor unit of the hand vacuum cleaner **A18**.
- It is possible to connect the brush nozzle or slot nozzle **A22** or **A21**, which are a part of the accessories, to the suction opening **A20**.
- To disassemble, proceed in the reverse sequence. To remove the dust container **A11**, press button **A17** and at the same time remove the dust container **A11**.

### 2. Upright vacuum cleaner

- To the body of the upright vacuum cleaner **A6**, connect the handle **A1** so that the connecting cable **A4** is inside the connection. Secure the connection with the supplied screw, see fig. **C**. Into the body of the upright vacuum cleaner **A6**, insert the assembled hand vacuum cleaner **A7** (without attachment **A21** or **A22**). Connect the floor nozzle **A9** to the bottom part of the body of the vacuum cleaner **A6**, see fig. **C**. The connection of the nozzle **A9** is indicated by the button **A8** sliding out.
- To disassemble, proceed in reverse sequence. To remove the floor nozzle **A9**, press the button **A8** and at the same time remove the nozzle **A9**. To take the hand vacuum cleaner **A7** out of the body of the upright vacuum cleaner **A6**, press the button **A5** and at the same time take out the hand vacuum cleaner **A7**.

### 3. Charging base

- Assemble the charging base **A23** by inserting the top part into the bottom part (see fig. **D**). To ensure better stability, the charging base **A23** can be attached to a wall using the attached screws, whilst it is necessary to ensure that the charging base **A23** is located within reach of a power socket.
- To disassemble, proceed in reverse sequence.

## PARKING POSITION OF THE VACUUM CLEANER

- Put the upright vacuum cleaner into the parking position by placing the tip of your foot on top of the floor nozzle **A9** and with a simple forward movement of the handle **A1** secure the vacuum cleaner in the vertical position. The latch located at the front on the elbow of the floor nozzle **A9** will slide into the groove on the top cover of the floor nozzle **A9**.
- To release the upright vacuum cleaner from the parking position, place the tip of your foot on top of the floor nozzle **A9** and tilt the handle **A1** backwards. The latch located at the front on the elbow of the floor nozzle **A9** will slide out of the groove on the top cover of the floor nozzle **A9**.

## CHARGING THE VACUUM CLEANER

- Locate the assembled charging base **A23** on an even, dry and stable surface within reach of a power socket.
- Connect the connector of the power adapter **A24** to the socket located on the side of the charging base **A23**, and insert the plug of the power adapter **A24** into a power socket.
- Place the upright vacuum cleaner, that you have previously turned off and put in the parking position, into the base **A23**, see fig. **E**. After being inserted into the charging base **A23**, the vacuum cleaner will switch to charging mode and the LED indicators **A16** will signal the power level of the built-in battery. A full charge requires approximately 6 hours. The actual charging time depends on the power level of the battery.
- Once the charging process is complete, all the LED indicators **A16** will be lit. Disconnect the power adapter **A23** from the power socket.

**Tip:**

This vacuum cleaner contains a built-in Li-ion battery. To ensure the longest possible lifetime of the battery, we recommend:

- do not unnecessarily leave the battery fully charged or completely flat for too long,
- do not keep the battery permanently fully charged. Its lifetime will be extended by keeping it at approximately half charge.
- do not fully discharge the battery.

**USING THE VACUUM CLEANER****1. Upright vacuum cleaner**

- You may use the vacuum cleaner for vacuuming various types of floor coverings such as for example hard floor coverings, carpets, etc.
- Hold the vacuum cleaner by the handle **A1** and pulling it upwards, remove it from the charging base **A23**. After removing from the charging base **A23**, the vacuum cleaner should be secured in the vertical parking position. After releasing it from the parking position, the handle may be moved in the vertical direction.
- Start the vacuum cleaner by pressing button **A2**. Use button **A3** to regulate the suction power of the vacuum cleaner and the speed of the rotary brush at two levels.
- The LED indicators **A16** signal the battery power level. The individual LED indicators **A16** will turn off as the battery gradually discharges. If it is discharged fully, all the LED indicators **A16** will be off and the vacuum cleaner will stop running.
- When you have finished using it, turn off the vacuum cleaner by pressing the button **A2**. Clean it according to the instructions contained in chapter Maintenance and cleaning, and allow it to charge according to the instructions contained in chapter Charging the vacuum cleaner.

**2. Hand vacuum cleaner**

- Turn on the hand vacuum cleaner by pressing button **A15**. You may use it for vacuuming locally soiled floor coverings, furniture, etc. Vacuuming hard to reach places is made easier by the slot nozzle **A21** and upholstered furniture by the brush nozzle **A22**.
- When you have finished using it, turn off the vacuum cleaner by pressing button **A15** again. Clean it according to the instructions contained in chapter Maintenance and cleaning, and allow it to charge according to the instructions contained in chapter Charging the vacuum cleaner.

**3. Cat & Dog Mini motorised brush**

Cat & Dog Mini motorised brush **A25** is provided with its own electric motor. Attach the motorised brush **A25** to the hand vacuum cleaner **A7**. Turn on the hand vacuum cleaner by pressing button **A15**. You may use it for vacuuming upholstery furniture or car interior. It easily removes hair or animal fur from the furniture, carpet, floor or car interior.

When you have finished using it, turn off the vacuum cleaner by pressing button **A15** again. Clean it according to the instructions contained in chapter Maintenance and cleaning, and allow it to charge according to the instructions contained in chapter Charging the vacuum cleaner.

**4. Using the mop attachment**

Attach the mop cover **G4** to the surface **G5**. Place the mop attachment **G1** with the attached mop cover **G4** on the ground. Fill in the tank **G2** by water or solution with the cleaning detergent. Avoid spilling water / solution from the filling outlets **G3** of the tank **G2**. Place the vacuum cleaner above the mop attachment **G1** so that the projections on the attachment **G1** were aligned with the holes at the bottom part of the floor nozzle **A9**. Wheels should

fit in the construction of the attachment **G1** - see picture H. Slightly push the vacuum cleaner down until you hear a click sound. That signals the correct securing of the attachment **G1** to the floor nozzle **A9**. Turn on the vacuum cleaner, and meanwhile you vacuum, the wheels will push on the switches in the attachment **G1**, these will release water / solution through the panel **G6** into the mop cover **G4** which will wipe the floor.

**Note:**

Regularly check the level of water / solution in the tank **G2** and fill it in if needed.

If you no longer use the mop attachment **G1**, pull up the vacuum cleaner. The switches in the attachment **G1** will be automatically released and water / solution stops flowing.

**MAINTENANCE AND CLEANING**

- Before cleaning, always make sure that the vacuum cleaner is turned off and the power adapter is disconnected from the power socket.

**Dust container and filters**

- Disassemble the hand vacuum cleaner **A7** according to the instructions in chapter Assembly and disassembly. Remove the contents of the dust container **A11**, rinse it out with water and thoroughly wipe dry.
- Remove dust and dirt from the external filter **A13**. Wash it under running water and then dry thoroughly, or allow it to dry naturally.
- In the event that the internal HEPA type filter **A12** is soiled, wash it under a gentle current of running water and allow it to dry naturally.

**Attention:**

Before assembling the vacuum cleaner, make sure that all its parts are completely dry. Prior to starting it, make sure that all the filters are properly installed in their place. Otherwise, this could damage the vacuum cleaner.

When filters are soiled, their effectiveness is reduced, so do not neglect their cleaning.

- After 6 months of use, we recommend replacing the internal HEPA type filter **A12** for a new one. Spare filters are available at brick and mortar, and online stores.

**Floor nozzle and attachments**

- If the rotary brush is soiled by hair or animal fur, remove the floor nozzle **A9** from the body of the vacuum cleaner **A6**. Turn it so that the rotary brush is pointing upwards. On the left side of the nozzle **A9** there is a latch that secures the brush cover in place, see fig. **F1**. Release the latch, tilt open the cover and take out the brush (see fig. **F2**).
- Remove all dirt and dust from the rotary brush and the internal space of the floor nozzle **A9**. After cleaning, return the rotary brush back in its place. Tilt the cover back and secure in place.
- For cleaning the surface of the floor nozzle **A9** and the attachments **A21** and **A22** use a dry or a lightly dampened cloth. Then wipe everything so that it is thoroughly dry.

**Outer surface of the vacuum cleaner**

- Clean the outer surface of the vacuum cleaner using a dry or a lightly dampened cloth. Then wipe everything so that it is thoroughly dry. Pay special attention when cleaning the body of the upright vacuum cleaner **A6**. In the part where the suction opening **A20** is located, dust may accumulate, which needs to be removed regularly.

- Clean the charging base **A23** using a dry or slightly dampened cloth, whilst ensuring that the socket for connecting the power adapter plug **A24** does not come into contact with moisture. Then wipe everything so that it is thoroughly dry.
- Do not use steel wool, abrasive cleaning products, solvents, etc. to clean the vacuum cleaner.

## TECHNICAL SPECIFICATIONS

### SVC 0625AT

#### Power adapter

Input ..... 100–240 V~, 50/60 Hz, 0.5 A

Output ..... 36 V ==, 400 mA

Electrical shock protection class ..... II

#### Vacuum Cleaner

Power input ..... 120 W

Electric rotary brush ..... 10 W

Battery ..... Li-ion / 25.2 V == / 2 000 mAh

Time required for charging to full capacity ... approximately 4 - 6 h

Operating time when fully charged (high/low power) . up to 22/50 minutes

Noise level ..... 79 dB(A)

Dust container capacity ..... 0.5 l

The declared noise emission level of the SVC 0625AT vacuum cleaner is 79 dB(A), which represents level A of acoustic power with respect to a reference acoustic power of 1 pW.

### Explanation of technical terminology

Safety class for electrical shock protection:

Class II – Electrical shock protection is provided by double or heavy-duty insulation.

We reserve the right to change text and technical specifications.

## INSTRUCTIONS AND INFORMATION REGARDING THE DISPOSAL OF USED PACKAGING MATERIALS

Dispose of used packaging material at a site designated for waste in your municipality.

## DISPOSAL OF USED ELECTRICAL AND ELECTRONIC EQUIPMENT



This symbol on products or original documents means that used electric or electronic products must not be added to ordinary municipal waste. For proper disposal, renewal and recycling hand over these appliances to determined collection points.

Alternatively, in some European Union states or other European countries you may return your appliances to the local retailer when buying an equivalent new appliance.

Correct disposal of this product helps save valuable natural resources and prevents potential negative effects on the environment and human health, which could result from improper waste disposal. Ask your local authorities or collection facility for more details.

In accordance with national regulations penalties may be imposed for the incorrect disposal of this type of waste.

## FOR BUSINESS ENTITIES IN EUROPEAN UNION STATES

If you want to dispose of electric or electronic appliances, ask your retailer or supplier for the necessary information.

### Disposal in other countries outside the European Union.

This symbol is valid in the European Union. If you wish to dispose of this product, request the necessary information about the correct disposal method from the local council or from your retailer.



This product meets all the basic requirements of EU directives related to it.

## DISPOSAL OF BATTERIES



Prior to disposing of the product or handing it over at a specialised collection facility, it is necessary to ensure that the built-in battery is removed. Before removing the battery, it is necessary to start the vacuum cleaner and wait until it is completely flat.

Battery removal will be performed at the authorised service centre. The battery contains environmentally damaging substances and therefore does not belong in standard household waste. Their correct disposal will be performed by the respective collection facility.