

# Ronix<sup>®</sup>

Premium Quality

## ELECTRIC DRILL 10MM 2115

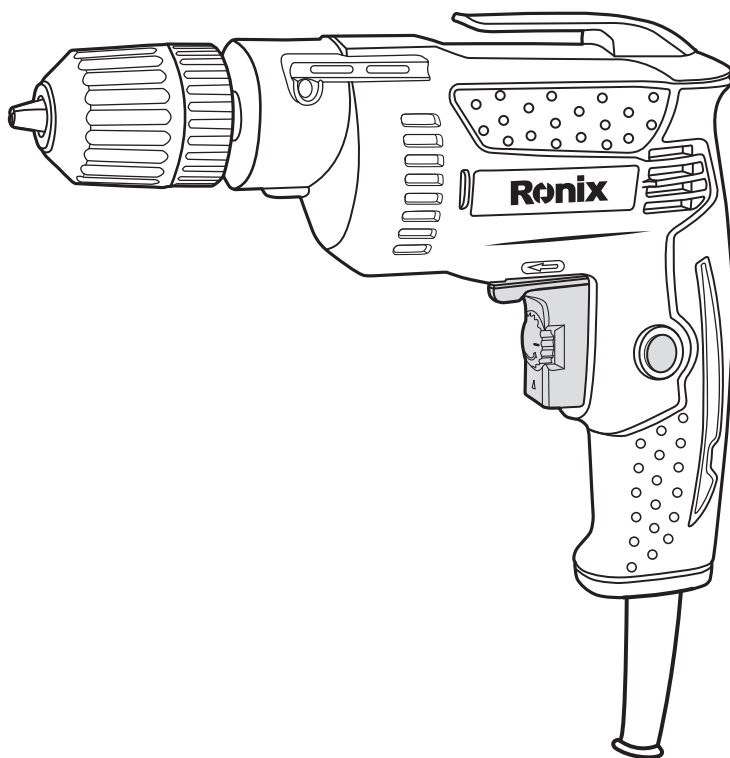

[www.ronixtools.com](http://www.ronixtools.com)

## SPECIFICATION

Model	2115
Power input	420W
voltage	220-240V
frequency	50-60Hz
No load speed	0-4200RPM
Chuck Type	Keyless
Chuck Size	10mm
Max Capacity in Wood	25mm
Max Capacity in Steel	10mm
Weight	1.54KG
Includes	pair of carbon brushes, Depth guage

## PART LIST

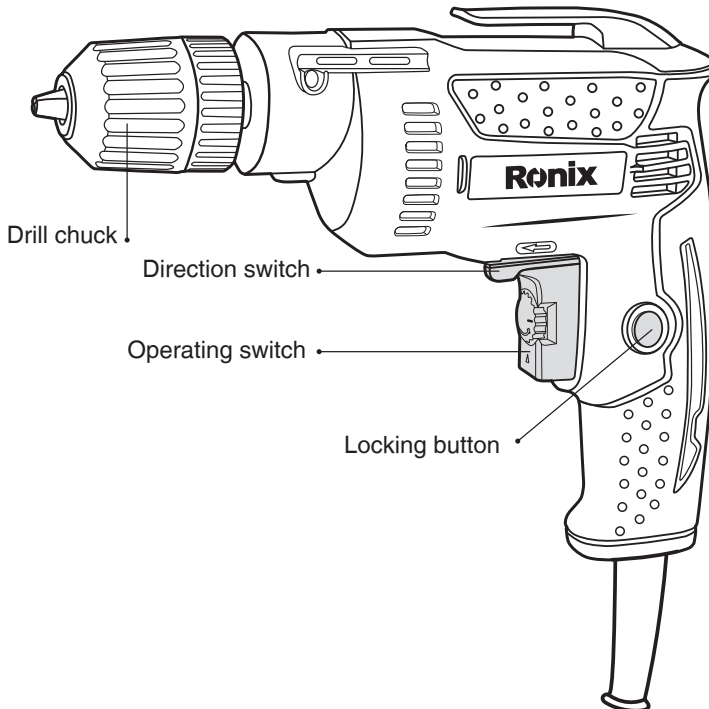

## GENERAL SAFETY RULES

### **NOTE:**

- In order to achieve the best performance of your product, please read this instruction manual carefully before using, and keep it for future reference.

### **CAUTION:**

- To reduce the risk of electric shock do not open this device, there are not serviceable parts for customers. Please refer any maintenance or repair to qualified personnel.

 This sign means the existence of dangerous voltage at the inside of the unit, which states a risk of electric shock.

 This sign means that there are important instructions of operation and handling in the manual that comes with this device.

## GENERAL POWER TOOL SAFETY WARNINGS

### **WARNING!**

- Read all safety warnings and all instructions. Failure to follow the warnings and instructions may result in electric shock, fire and or serious injury.
- Save all warnings and instructions for future reference.
- The term “power tool” in the warnings refers to your mains-operated (corded) power tools or battery operated (cordless) power tool.

### **■ WORK AREA SAFETY**

- Keep work area clean and well lit. Cluttered or dark areas invite accidents.
- Don't operate power tools in explosive atmospheres, such as in the presence of flammable liquids, gases or dust. Power tools create sparks which may ignite the dust or fumes.
- Keep children and bystanders away while operating a power tool. Distractions can cause you to lose control.

## ■ ELECTRIC SAFETY

- Power tool plugs must match the outlet. Never modify the plug in any way.
- Don't use any adaptor plugs with earthed (grounded) power tools. Unmodified plugs and matching outlets will reduce risk of electric shock.
- Avoid body contact with earthed or grounded surfaces such as pipe, radiators, ranges and refrigerators. There is an increased risk of electric shock if your body is earthed or grounded.
- Don't expose power tools to rain or wet conditions. Water entering a power tool will increase the risk of electric shock.
- Don't abuse the cord. Never use the cord for carrying, pulling or unplugging the power tool. Keep cord away from heat, oil, sharp edges or moving parts. Damaged or entangled cords increased the risk of electric shock.
- When operating a power tool outdoors, use an extension cord suitable for outdoor use. Using a cord suitable for outdoor use will reduce the risk of electric shock.
- If operating a power tool in a damp location is unavoidable, use a residual current device (RCD) protected supply. Use of an RCD reduces the risk of electric shock.
- Use of power supply via a RCD with a rated residual current of 30mA or less is always recommended.

## ■ PERSONAL SAFETY

- Stay alert, watch what you are doing and use common sense when operating a power tool. Don't use a power tool while you are tired or under the influence of drugs, alcohol or medication. A moment of inattention while operating power tools may result in serious personal injury.
- Use personal protective equipment. Always wear eye protection. Protective equipment such as dust mask, non-skid safety shoes, hard hat, or hearing protection used for appropriate conditions will reduce personal injuries.
- Prevent unintentional starting. Ensure the switch is in the off-position before connecting to power source and/or battery pack, picking up or

carrying the tool. Carrying power tools with your finger on the switch or energizing power tools that have the switch on invites accidents.

- Remove any adjusting key or wrench before turning the power tool on. A wrench or a key left attached to a rotating part of the power tool may result in personal injury.
- Don't overreach. Keep proper footing and balance at all times. This enables better control of the power tool in unexpected situations.
- Dress properly. Don't wear loose clothing or jewelry. Keep your hair, clothing, and gloves away from moving parts. Loose cloths, jewelry or long hair can be caught in moving parts.
- If devices are provided for connection of dust extraction and collection facilities, ensure these are connected and properly used. Use of dust collection can reduce dust-related hazards.

## **POWER TOOL USE AND CARE**

- Don't force the power tool. Use the correct power tool for your application. The correct power tool will do the job better and safer at the rate for which it was designed.
- Don't use the power tool if the switch doesn't turn it on and off. Any power tool that cannot be controlled with the switch is dangerous and must be repaired.
- Disconnect the plug from the power source and/or the battery pack from the power tool before making any adjustments, changing accessories, or storing power tools. Such preventive safety measures reduce the risk of starting the power tool accidentally.
- Store idle power tools out of the reach of children and don't allow persons unfamiliar with power tool or these instructions to operate the power tool. Power tools are dangerous in the hands of untrained users.
- Maintain power tools. Check for misalignment or binding of moving parts, breakage of parts and any other condition that may affect the power tool's operation. If damaged, have the power tool repaired before use. Many accidents are caused by poorly maintained power tools.
- Keep cutting tools sharp and clean. Properly maintained cutting tools

with sharp cutting edges are less likely to bind and are easier to control.

- Use the power tool, accessories and tool bits etc. in accordance with the instruction, taking into account the working conditions and the work to be performed. Use of the power tool for operations different from those intended could result in a hazardous situation.

## **SERVICE**

- Have your power tool serviced by qualified repair person using only identical replacement parts. This will ensure that the safety of power tool is maintained.
- Follow instruction for lubricating and changing accessories.
- Keep handles dry, clean and free from oil and grease.

## **ELECTRIC DRILL SAFETY WARNINGS**

- Wear ear protectors when impact drilling. Exposure to noise can cause hearing loss.
- Hold power tool by insulated gripping surface, when performing an operation where the cutting accessory may contact hidden wiring or its own cord. Cutting accessory contacting a “live” wire may make exposed metal parts of the power tool “live” and could give the operator and electric shock.
- Always be sure you have a firm footing. Be sure no one is below when using the tool in high locations.
- Hold the tool firmly with both hands.
- Keep hands away from rotating parts.
- Don't leave the tool running. Operate the tool only when hand-held.
- Don't touch the bit or the work piece immediately after operation; they may be extremely hot and cold burn your skin.
- Some material contains chemical which may be toxic. Take caution to prevent dust inhalation and skin contact. Follow material supplier safety data.

## THIS DRILL HAS THE FOLLOWING FUNCTION

- The operating switch is used for all work carried out with the drilling machine.
- The machine can be set to continuous operation with the locking button.
- The direction switch controls the direction of motion when the machine is used as a screwdriver or if you would like to remove a drilling bit that has become jammed.

## PREPARING THE DRILLING MACHINE

### **WARNING!**

- When performing the following work, always ensure that the machine is not connected to the mains power supply.

## INSERTING THE DRILL

- First remove the mains supply from the socket. Turn the ring of the drill chuck until the clamping jaws are open wide enough. Insert the drill into the clamping jaws of the drill chuck.

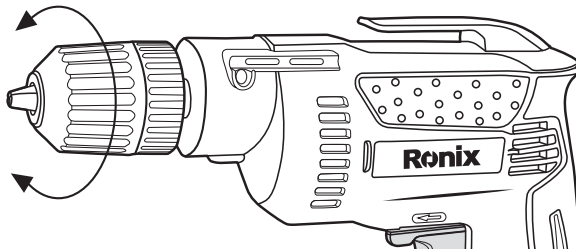

## OPERATING SWITCH

- The machine is switched on by pressing the operating switch. When the operating switch is released, the machine stops. If you would like to use continuous operation press the locking button while the operating switch is pressed. In order to switch off the machine during continuous operation, press the operating switch again and then let it go.

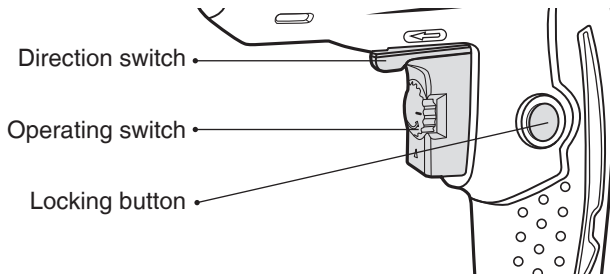

## WORKING WITH THE DRILLING MACHINE

- Ensure that the mains power supply voltage is the same as the operating voltage of your machine. For details, please see the type plate. Insert the correct drill for the type of job to be performed. The more the operating switch is pressed in, the faster the drill rotates. Set the direction switch to the desired direction of motion. The machine is switched on by pressing the operating switch. When the operating switch is released, the machine stops. If you would like to use continuous operation press the locking button while the operating switch is pressed. In order to switch off the machine during continuous operation, press the operating switch again and then let it go. Do not touch the drill chuck while the machine is switched on.

## DRILLING TIPS

- Always insert the correct size and type of drill or screwdriver.
- Set the direction switch to the correct direction.
- Never change the direction of motion when the machine is switched on.

## CARE OF THE TOOLS

### ■ OVERLOAD

- Never use excessive force when drilling. Too much pressure reduces the speed of the machine, and the required power is greatly reduced. This may result in overlo–ad, which can damage the motor of the drilling

machine. When the drilling machine becomes too hot, allow it to run for two minutes without a load and then interrupt working for a short time. Clean the drilling machine with a clean cloth and a brush. Ensure that the ventilation slits are not blocked.



**WARNING!**

- Always use the additional grips which come with the appliance. Losing control of the appliance may result in injuries.



**Ronix**<sup>®</sup>  
Premium Quality

[www.ronixtools.com](http://www.ronixtools.com)