

# Setup Guide

Solar Panel

ring



22-004192-01

## Hardware included

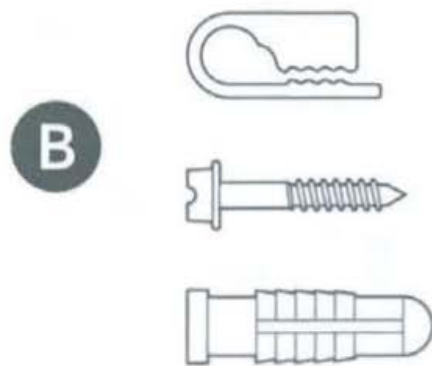
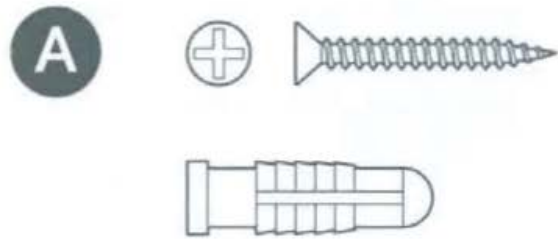

## Tools needed

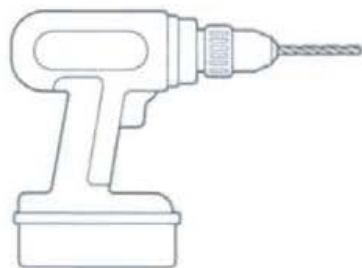

## Choose an install location with the most direct sunlight.

If you are in the Northern Hemisphere, direct your solar panel toward the south.

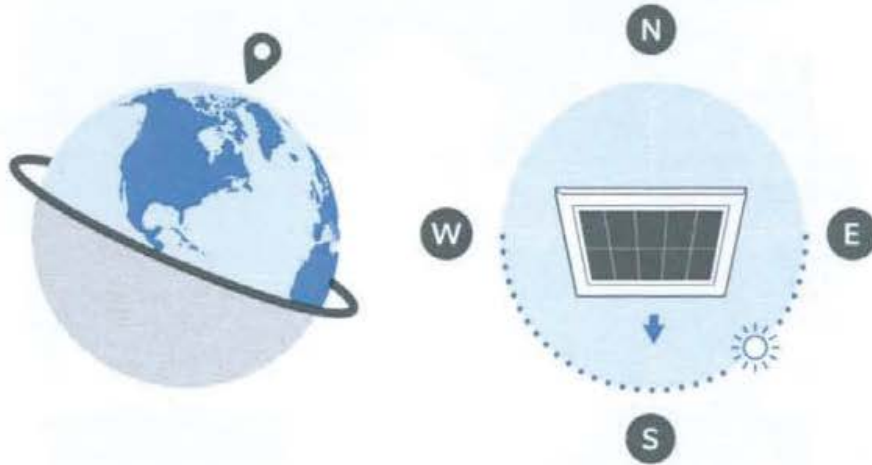

If you are in the Southern Hemisphere, direct your solar panel toward the north.

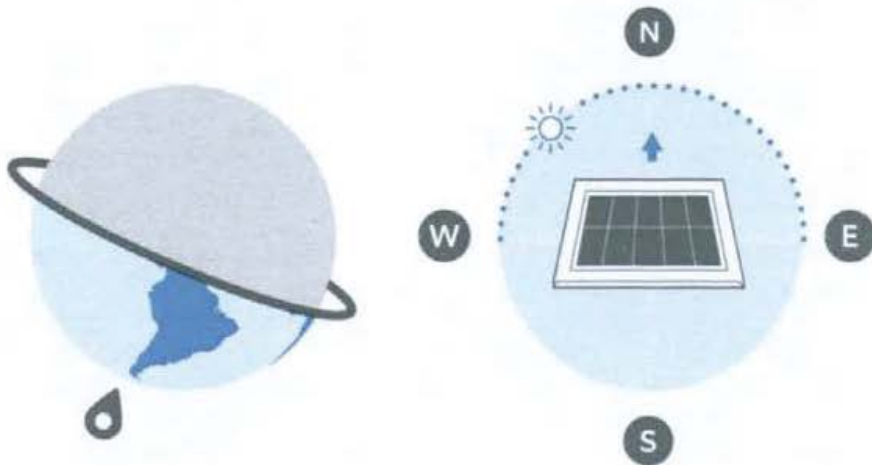

Make sure there is nothing blocking sunlight from the solar panel.

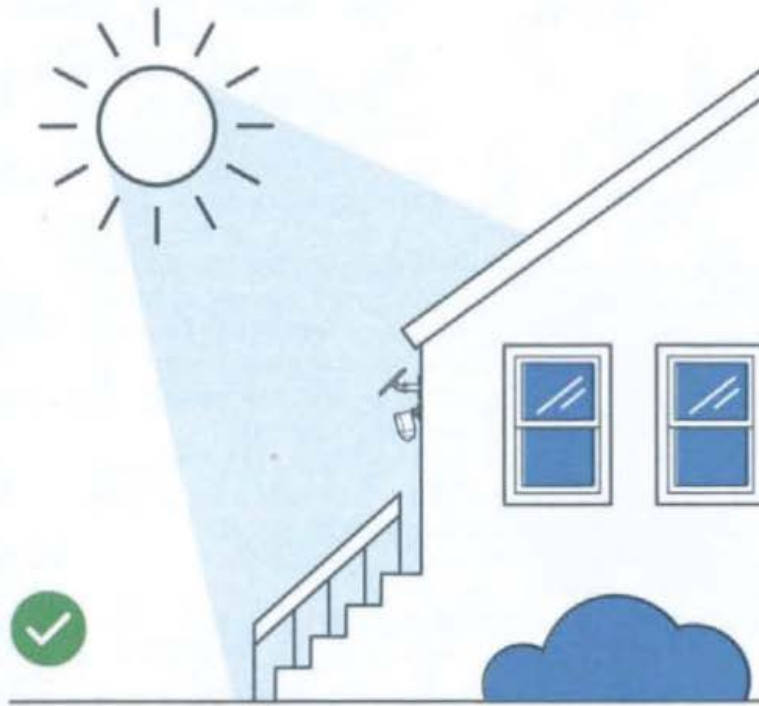

1

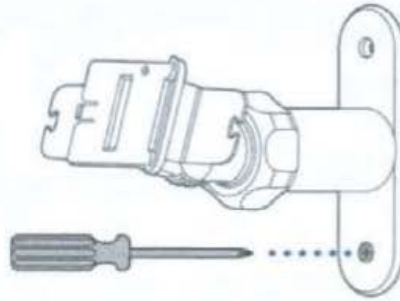

A

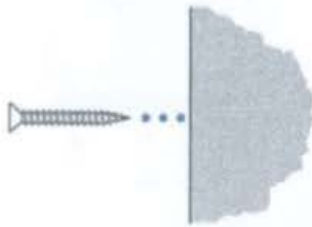

A

6mm | 1/4 in

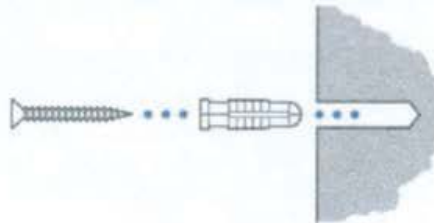
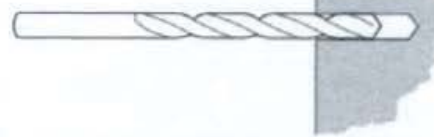

**CAUTION!** Do not drill or drive screws into your home's electrical wiring.

2

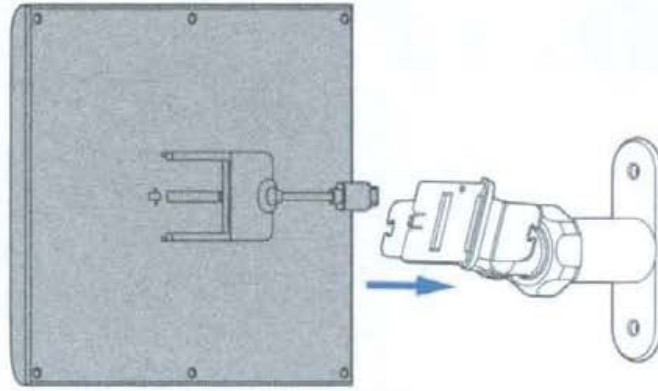

3

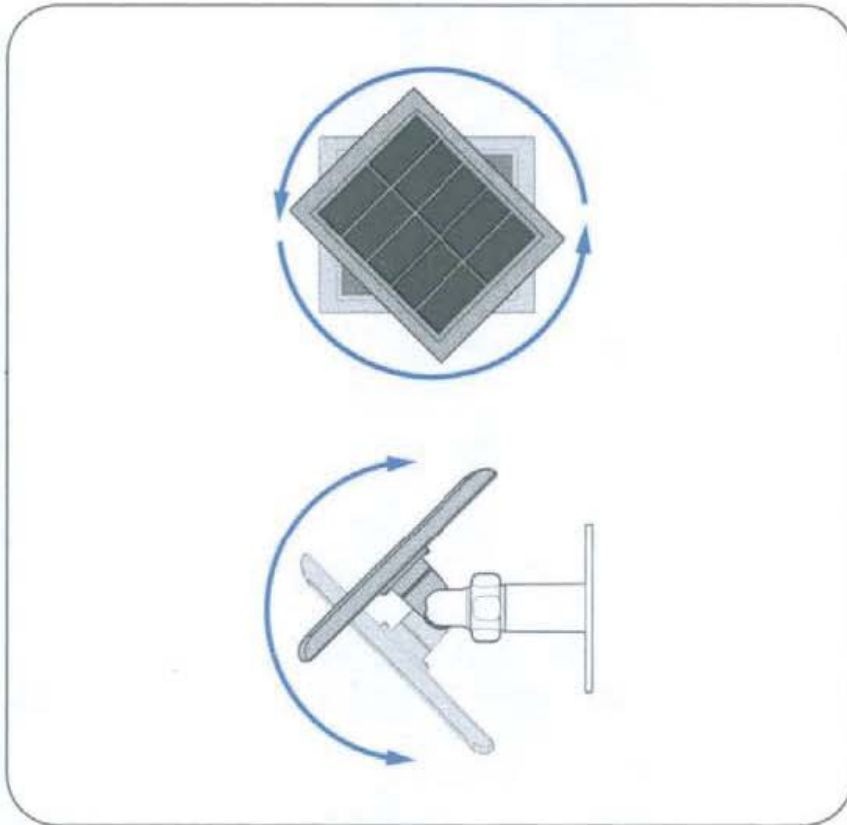
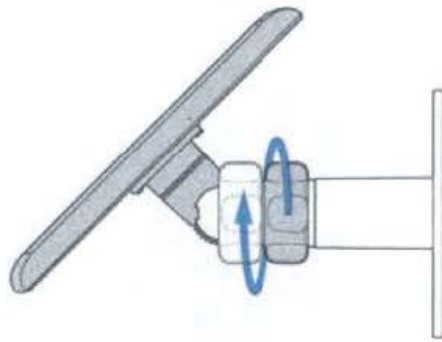

4

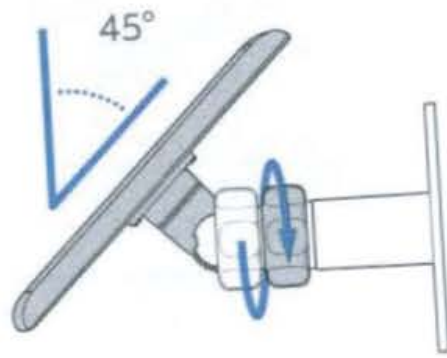

5

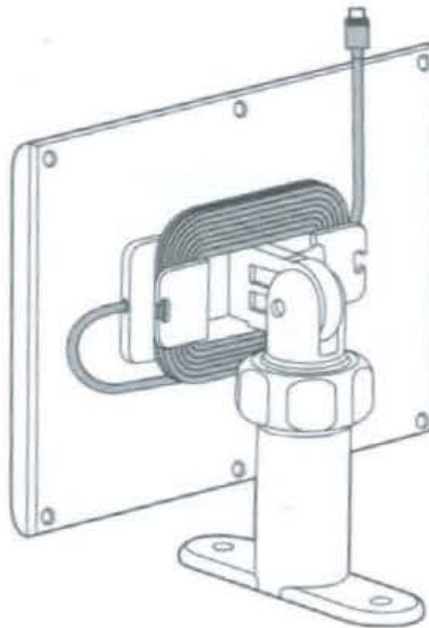

## 6 USB-C

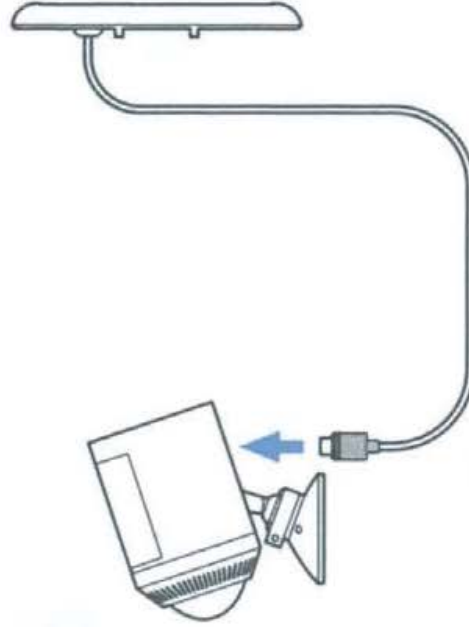

## Barrel Connector

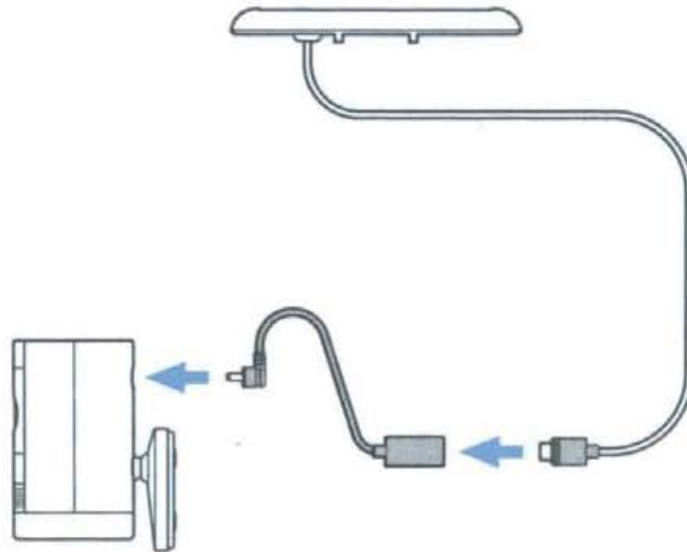

7

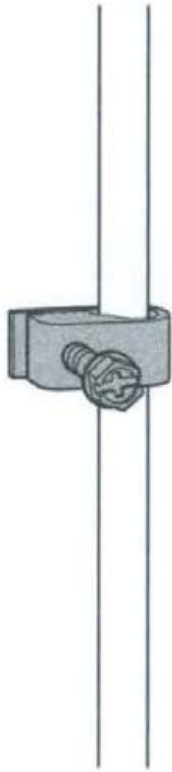

B

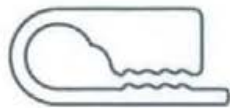

## INFORMATION ABOUT YOUR PRODUCT

### SAFETY INFORMATION



**DANGER!** Failure to follow these safety instructions could result in fire, electric shock, or other injury or damage.



**CHOKING HAZARD:**

Small parts in the installation kit could present a choking hazard.

Your device is water resistant and is suitable for outdoor use. However, your charger is not intended for underwater use. To protect against electric shock, do not intentionally submerge or immerse your charger in water or expose your charger to other liquids. Do not spill any food or beverages on your charger. Do not attempt to clean or polish your charger with or expose your charger to oil, lotion, or other abrasive substances. Do not expose your charger to pressurised water, high velocity water, or extremely humid conditions (such as a steam room). Do not attempt to dry your charger with an external heat source, such as a microwave oven or a hair dryer. To avoid risk of electric shock, do not touch your device or any wires connected to your device during a lightning storm while your device is plugged in. If your charger appears to be damaged, discontinue use immediately.

Use only accessories supplied with your device, or specifically marketed for use with your device, to power your device. Use of third-party accessories may impact your device's performance. In limited circumstances, use of third party accessories may void your device's limited warranty. In addition, use of incompatible third-party accessories may cause damage to your device or the third-party accessory. Read all safety instructions for any accessories before using with your device.

For device compatibility information, visit [ring.com/compatibility](https://ring.com/compatibility)

### PRODUCT SPECIFICATIONS

**Model Number:** 5F80E9

**Operating Temperature:** -5°F to 120°F (-20.5°C to 48.5°C)

**Maximum Power Output:** 5V DC, 800mA, 4W

### RECYCLING YOUR DEVICE PROPERLY

In some areas, the disposal of certain electronic devices is regulated. Make sure you dispose of, or recycle, your device in accordance with your local laws and regulations. For information about recycling your device, go to [amazon.com/devicesupport](https://amazon.com/devicesupport)

### TERMS OF SERVICE AND WARRANTY

By purchasing or using the product, you agree to the Terms of Service found at [ring.com/terms](https://ring.com/terms). For information on our warranty, Theft Protection, and Ring Protect plans, visit [ring.com/legal](https://ring.com/legal)

## FOR USERS IN THE UNITED STATES

### FCC Compliance Statement

This device complies with part 15 of the FCC Rules. Operation is subject to the following two conditions: (1) This device may not

cause harmful interference, and (2) This device must accept any interference received, including interference that may cause undesired operation.

NOTE: This equipment has been tested and found to comply with the limits for a Class B digital device, pursuant to part 15 of the FCC Rules.

These limits are designed to provide reasonable protection against harmful interference in a residential installation. This equipment generates, uses and can radiate radio frequency energy and, if not installed and used in accordance with the instructions, may cause harmful interference to radio communications.

However, there is no guarantee that interference will not occur in a particular installation. If this equipment does cause harmful interference to radio or television reception, which can be determined by turning the equipment off and on, the user is encouraged to try to correct the interference by one or more of the following measures:

- Reorient or relocate the receiving antenna.
- Increase the separation between the equipment and receiver.
- Connect the equipment into an outlet on a circuit different from that to which the receiver is connected.
- Consult the dealer or an experienced radio/TV technician for help.

Pursuant to Section 15.21 of the FCC rules, changes or modifications to a Product by the user that are not expressly approved by the party responsible for compliance could void the user's authority to operate the equipment. The device meets the FCC Radio Frequency Emission Guidelines. Information on the product is on file with the FCC and can be found by inputting such Product's FCC ID (which can be found on the device) into the FCC ID Search form available at [fcc.gov/oet/ea/fccid](http://fcc.gov/oet/ea/fccid).

The party responsible for FCC compliance is Ring LLC, 12515 Cerise Ave, Hawthorne, CA 90250 USA.

#### **FCC Radiation Exposure Statement**

This device complies with FCC radiation exposure limits set forth for an uncontrolled environment and it also complies with Part 15 of the FCC RF Rules.

This equipment must be installed and operated in accordance with provided instructions and the antenna(s) used for this transmitter must be installed to provide a separation distance of at least 20 cm from all persons and must not be co-located or operated in conjunction with any other antenna or transmitter.

## **FOR CUSTOMERS IN AUSTRALIA AND NEW ZEALAND**

#### **One-Year Limited Warranty for Ring Devices**

If you purchased your Ring devices and accessories (the "Device") from Ring, Amazon or from authorised resellers, the Warranty for the Device is provided by Ring LLC, 12515 Cerise Avenue, Hawthorne, CA 90250, United States ("Ring"). The provider of this warranty is sometimes referred to herein as "we".

When you purchase a new or Certified Refurbished Device, we warrant the Device against defects in materials and workmanship

under ordinary consumer use for one year from the date of original retail purchase. During this warranty period, if a defect arises in the Device, and you follow the instructions for returning the Device, we will at our option, to the extent permitted by law, either (i) repair the Device using either new or refurbished parts, (ii) replace the Device with a new or refurbished Device that is equivalent to the Device to be replaced, or (iii) refund to you all or part of the purchase price of the Device. This limited warranty applies, to the extent permitted by law, to any repair, replacement part or replacement device for the remainder of the original warranty period or for ninety days, whichever period is longer. All replaced parts and Devices for which a refund is given shall become our property. This limited warranty applies only to hardware components of the Device that are not subject to accident, misuse, neglect, fire or damage from other external causes, alteration, or repair.

**Instructions.** For specific instructions about how to obtain warranty service for your Device, please contact Ring community support at: <https://support.ring.com> or call 61 2 8294 9169 or 1 300 205 983 (Australia) or 64 9887 9871 (New Zealand).

In general, you will need to deliver your Device in either its original packaging or in equally protective packaging to the address specified by Customer Service. Before you deliver your Device for warranty service, it is your responsibility to remove any removable storage media and back up any data, software, or other materials you may have stored or preserved on your Device. It is possible that such storage media, data, software or other materials will be destroyed, lost or reformatted during service, and we will not be responsible for any such damage or loss.

**Limitations.** TO THE EXTENT PERMITTED BY LAW, THE WARRANTY AND REMEDIES SET FORTH ABOVE ARE EXCLUSIVE AND IN LIEU OF ALL OTHER WARRANTIES AND REMEDIES, AND WE SPECIFICALLY DISCLAIM ALL STATUTORY OR IMPLIED WARRANTIES, INCLUDING, BUT NOT LIMITED TO, WARRANTIES OF MERCHANTABILITY, FITNESS FOR A PARTICULAR PURPOSE AND AGAINST HIDDEN OR LATENT DEFECTS. IF WE CANNOT LAWFULLY DISCLAIM STATUTORY OR IMPLIED WARRANTIES, THEN TO THE EXTENT PERMITTED BY LAW, ALL SUCH WARRANTIES SHALL BE LIMITED IN DURATION TO THE DURATION OF THIS EXPRESS LIMITED WARRANTY AND TO REPAIR OR REPLACEMENT SERVICE.

SOME JURISDICTIONS DO NOT ALLOW LIMITATIONS ON HOW LONG A STATUTORY OR IMPLIED WARRANTY LASTS, SO THE ABOVE LIMITATION MAY NOT APPLY TO YOU. WE ARE NOT RESPONSIBLE FOR DIRECT, SPECIAL, INCIDENTAL OR CONSEQUENTIAL DAMAGES RESULTING FROM ANY BREACH OF WARRANTY OR UNDER ANY OTHER LEGAL THEORY. IN SOME JURISDICTIONS THE FOREGOING LIMITATION DOES NOT APPLY TO DEATH OR PERSONAL INJURY CLAIMS, OR ANY STATUTORY LIABILITY FOR INTENTIONAL AND GROSS NEGLIGENT ACTS AND/OR OMISSIONS, SO THE ABOVE EXCLUSION OR LIMITATION MAY NOT APPLY TO YOU. SOME JURISDICTIONS DO NOT ALLOW THE EXCLUSION OR LIMITATION OF DIRECT, INCIDENTAL OR CONSEQUENTIAL DAMAGES, SO THE ABOVE EXCLUSION OR LIMITATION MAY NOT APPLY TO YOU. THIS "LIMITATIONS" SECTION DOES NOT APPLY TO CUSTOMERS IN THE EUROPEAN UNION AND THE UNITED KINGDOM.

This limited warranty gives you specific rights which are in addition to the statutory rights to which you may be entitled under applicable law.

**FOR AUSTRALIAN CONSUMERS:** Our goods come with guarantees that cannot be excluded under the Australian Consumer Law. You are entitled to a replacement or refund for a major failure and for compensation for any other reasonably foreseeable loss or damage. You are also entitled to have the goods repaired or replaced if the goods fail to be of acceptable quality and the failure does not amount to a major failure, provided repair facilities and parts for the goods are available.

Subject to any rights that you may have under the Australian Consumer Law, you may be required to bear the expense of claiming under this limited warranty, including the cost of returning the Device.

**FOR NEW ZEALAND CONSUMERS:** Our goods come with guarantees that cannot be excluded under the Consumer Guarantees Act 1993. You are entitled to a repair, replacement, or refund if the goods we provide to you are not of acceptable quality, are not fit for a particular purpose made known by you the consumer or represented by Ring, or do not correspond with what is advertised by Ring. Ring does not undertake that repair facilities and parts will be available for our goods. You are also entitled to reject the goods and receive a refund or replacement from Ring if the failure of the goods to comply with guarantees in the Consumer Guarantees Act cannot be remedied, or the failure is of substantial character. In addition, you may be entitled to compensation for reasonably foreseeable loss or damage. The above terms do not apply to goods purchased for commercial use.



For additional help, visit [ring.com/help](https://ring.com/help)  
Or give us a call

[US 1 800 656 1918](tel:18006561918)

[Canada 1 855 300 7289](tel:18553007289)

[Worldwide +1 310 929 7085](tel:+13109297085)

For a list of all our customer support numbers, visit [ring.com/callus](https://ring.com/callus)

For information on our warranty, theft protection, and Ring Protect Plans, visit [ring.com/legal](https://ring.com/legal)

© 2022 Ring LLC or its affiliates. Ring and all related marks are trademarks of Ring LLC or its affiliates.

