

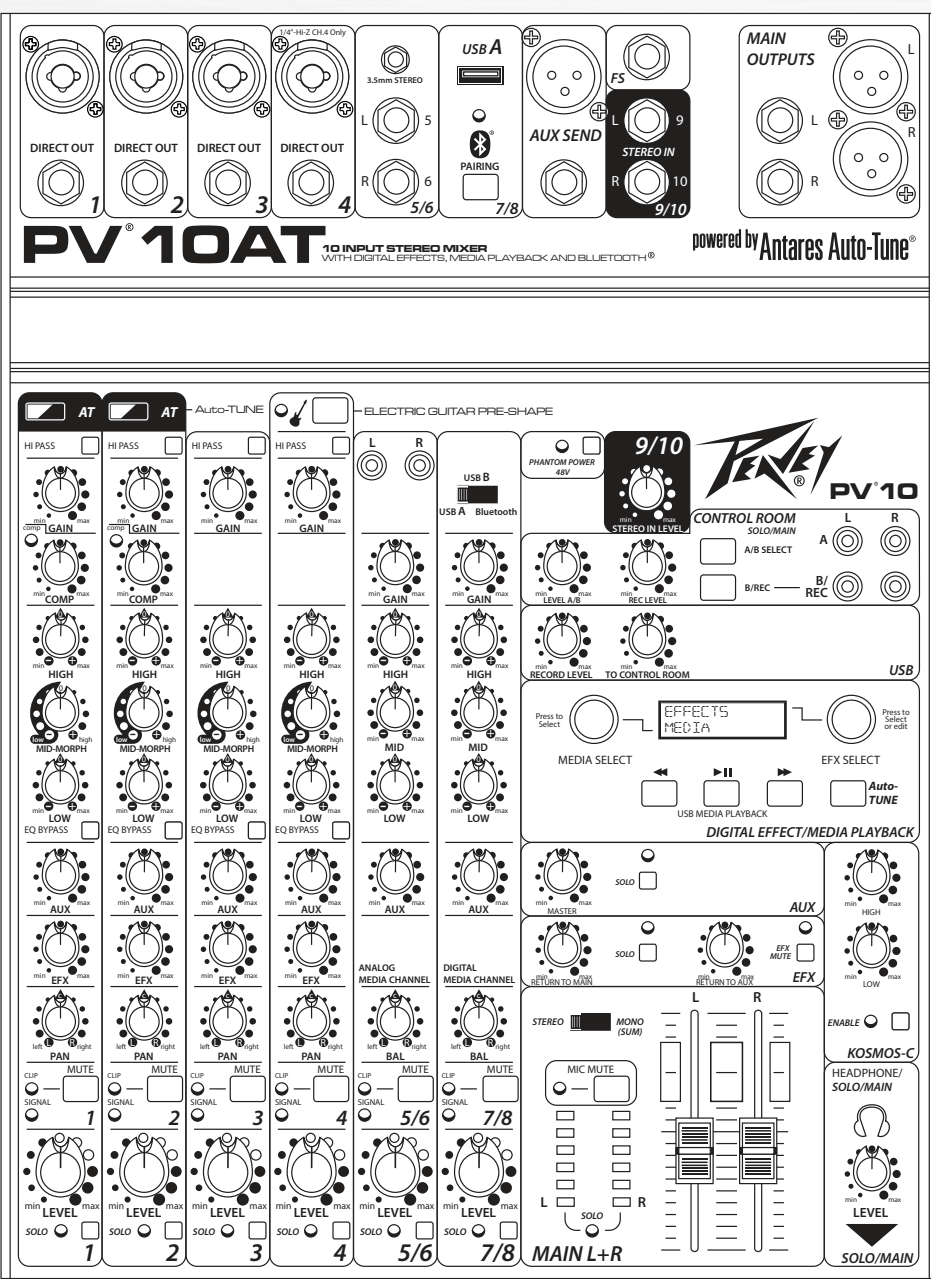

PV[®]10AT • PV[®]BT

Compact Mixer

Operating Manual





FCC/ICES Compliancy Statement

This device complies with Part 15 of the FCC rules and Industry Canada license-exempt RSS Standard(s). Operation is subject to the following two conditions: (1) this device may not cause harmful interference, and (2) this device must accept any interference received, that may cause undesired operation.

Le présent appareil est conforme aux CNR d'Industrie Canada applicables aux appareils radio exempts de licence. L'exploitation est autorisée aux deux conditions suivantes: (1) l'appareil ne doit pas produire de brouillage, et (2) l'utilisateur de l'appareil doit accepter tout brouillage radioélectrique subi, même si le brouillage est susceptible d'en compromettre le fonctionnement.

Warning: Changes or modifications to the equipment not approved by Peavey Electronics Corp. can void the user's authority to use the equipment.

Note – This equipment has been tested and found to comply with the limits for a Class B digital device, pursuant to Part 15 of the FCC Rules. These limits are designed to provide reasonable protection against harmful interference in a residential installation. This equipment generates, uses, and can radiate radio frequency energy and, if not installed and used in accordance with the instructions, may cause harmful interference to radio communications. However, there is no guarantee that interference will not occur in a particular installation. If this equipment does cause harmful interference to radio or television reception, which can be determined by turning the equipment off and on, the user is encouraged to try and correct the interference by one or more of the following measures.

- Reorient or relocate the receiving antenna.
- Increase the separation between the equipment and receiver.
- Connect the equipment into an outlet on a circuit different from that to which the receiver is connected.
- Consult the dealer or an experienced radio/TV technician for help.

Caution

The equipment complies with FCC radiation exposure limits set forth for an uncontrolled environment.



Features and specifications are subject to change without notice.

Peavey Electronics Corporation • 711 A Street • Meridian, MS 39301

(601) 483-5365 • FAX (601) 486-1278 • www.peavey.com

PV[®]10AT and PV[®]10BT

Compact Mixers

Congratulations on purchasing the Peavey PV[®]10AT or PV[®]10BT Compact Mixer. The PV[®]10AT and PV[®]10BT are studio-quality mixing consoles designed to meet diverse needs while occupying a small space. These are the perfect consoles for small venue performances or home recording environments. PV series mixers feature built-in DSP effects that are useful in real-world recording and sound reinforcement, while parameter controls allow you to tailor each effect to meet your needs.

The PV 10 BT includes 4 channels of reference-quality mic preamps, 4 direct outputs for recording, a stereo channel, media channel with Bluetooth wireless input, high quality digital effects with LCD display, streaming USB out, MP3 playback via USB A input, Peavey's exclusive Kosmos audio enhancement, 48 volt phantom power, dual selectable control room outputs, 2 channels of compression, one channel of on board selectable guitar preamp, 3-band EQ per channel with bypass, channel mute buttons, aux send, signal clip indicators, and a stereo master LED meter bridge. This amazingly versatile mixer is at home both in the studio as well as live applications. Its modern features such as Bluetooth allow seamless connection to almost any "smart" device. 4 direct outs allow easy connection to most DAW interfaces for recording; in addition, the PV 10 BT can stream audio directly to a PC. MP3 playback is also available, just plug a flash drive with MP3 files on it into the USB A port and use the LCD to select and playback music. The PV series Solo feature allows the user to listen to individual channels via headphone or control room outputs and the EQ bypass allows the user to compare the EQ'd signal to the original signal with the push of a button. 2 Channels of compression keep signals with difficult levels under control, and Peavey's exclusive guitar-shape adjusts the EQ and preamp specifically for guitar. Hi pass filters on every channel remove unwanted rumble and noise, and balanced AUX and Master outputs ensure a clean noise free signal to your powered speakers or power amplifier. The all new PV series non-powered mixers represent the pinnacle of performance and value. Combine Peavey's legendary reliability and our 5 year warranty and you can be assure of years of quality reliable service, we guarantee it.

In addition to all of these features, the PV10AT features 2 channels of Antares[®] world-famous Autotune[®], which can be set to subtly tighten up vocal harmonies, or it can be set for robotic vocal effects heard in today's popular music. Peavey's exclusive custom key feature makes it a snap to auto-tune to any scale you can think of, in a live performance. It is so easy and fast, you can set it up between songs, right in the middle of a set.

Please read this guide carefully to ensure your personal safety as well as the safety of your equipment.

FEATURES:

- 4 Combination 1/4" and XLR low noise mic preamps
- Stereo 1/4", RCA or 3.5mm input channel
- Bluetooth wireless connectivity
- 3-band EQ on all channels
- 4 Channels of Peavey's Exclusive Mid-Morph
- 150 Hz low-cut switch on all mic inputs
- LED clip and signal present indication
- Individual channel mutes
- EQ Bypass per mic channel
- On board studio quality digital effects with individual channel control
- Effects and playback LCD display
- One pre-fader AUX send
- Precision 60 mm faders on master
- Dual selectable control room outputs / Record out with independent level
- Global 48V phantom power
- Main stereo outputs with balanced 1/4" and XLR connectors
- Rugged console design
- 2 channels of built-in compression
- Stereo pan control per channel
- On-board USB-A MP3 playback
- 4 Channels of direct out
- Kosmos -C bass and treble enhancement
- Channel 9/10 stereo return/input
- Individual Solo function
- Stereo USB-B streaming audio in and out
- High quality master LED meter bridge
- Master mic mute
- Studio quality headphone output
- Peavey's exclusive on-board 1 Meg guitar input
- Antares Auto-Tune with Peavey's exclusive Custom Key feature



Installation Note:

This unit must have the following clearances from any combustible surface: top: 8", sides: 12", back: 12"

PV10AT Front Panel (channels 1 and 2)

1 MIC/LINE INPUT (CH.1-8)

This combination input jack accepts a 1/4" or XLR balanced plug. The XLR balanced input is optimized for a microphone or other low impedance source. The 1/4" input is a TRS balanced type, and also accepts ordinary TS guitar cables.

2 DIRECT OUT

This impedance-balanced TRS output signal is taken after the mic preamp, hi pass filter, and compressor, but before the EQ stage.

3 AUTO-TUNE ACTIVATION BUTTON AND LED (PV10AT only)

Pressing this button activates the PV10AT's onboard AUTO-TUNE feature. The button illuminates when in AUTO-TUNE mode (SEE Effects Select {50} and the following page).

4 GAIN

The Input Gain control is used to establish proper gain structure in the channel. For best results, use the Solo system (19) to monitor the channel while you set the gain. The goal is maximum gain without distortion. Both the main LED meters (during Solo) and the channel's Signal/Clip indicator (16,17) can be used for adjusting gain. If the clip LED (16) comes on and remains lit, try reducing the gain.

5 150 Hz HI PASS FILTER

The hi pass filter has a corner frequency of 150 Hz. When engaged, it can improve clarity by removing low frequencies that make a mix sound muddy. This feature is especially useful when playing outside on a windy day or on a hollow-sounding, noisy stage. These kinds of ambient noises can rob your sound system of power. Engaging this switch will remove those frequencies from the system and restore power where needed.

6 COMPRESSION CONTROL (Channels 1 and 2 only)

Adjusting this knob clockwise lowers the threshold of the compressor, thereby increasing the amount of compression. The compressor ratio is in the 4:1 range, varying with signal levels and the amount of compression. This is useful for controlling peak levels from live sources, and has been designed to subtly tame the levels of live vocals without noticeable artifacts. The compressor is after the gain control (5) and the hi pass filter (4), but before the direct out (2), so it can be patched to external equipment.

7 Compressor LED

This LED illuminates when the compressor is actively compressing a signal.

8 Hi EQ

This active tone control (shelving type: ±15 dB) varies the level of the high frequency range.

9 MID-MORPH EQ (CH. 1-7)

Where most mid-range controls work at just one frequency, the Mid-Morph works at two. When turned counterclockwise, it cuts at 250Hz to reduce frequencies that muddy the sound. When turned clockwise, it boosts at 4kHz to add intelligibility to vocals. Either way, improved vocal or instrument definition can be achieved.

10 Low EQ

This active tone control (shelving type: ±15 dB) varies the level of the low frequency range. Caution: Excessive low frequency boost causes greater power consumption and increases the possibility of speaker damage.

11 EQ BYPASS

Engaging this button bypasses the equalization of the channel, allowing you to easily hear the effect of the EQ settings.

12 AUX SEND

This control adjusts the level of the channel signal sent to the Aux output. The signal is taken before the channel level (18) but after the channel EQ, meaning that changes to the EQ settings will affect the aux mix, but changes to the channel level control won't. Typical use for the Aux bus is to feed stage monitors, when used in a live performance, or to feed headphone amplifiers in a recording situation.

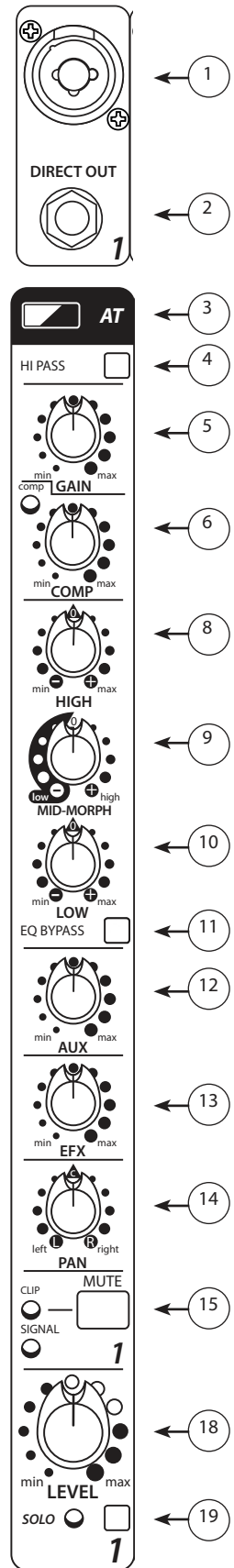

PV10AT Front Panel (channels 1 and 2)

13 EFX SEND

This control adjusts the level of the channel signal added to the effects mix. The signal is sent to the internal effects processor. Turning the knob to the left (min) will turn off effects on the associated channel, while turning the knob to the right will increase the amount of the selected effect. The effects send signal is taken after the channel level (18) so that adjustments made to the fader will also affect the send level.

14 PAN CONTROL

This knob controls the placement of the signal in the stereo field. When rotated completely counterclockwise, the signal is present only on the left channel; when rotated completely clockwise, only in the right channel. This control functions as a balance control to adjust the relative level of the left and right signals on stereo channels 5/6 and 7/8. (Note 1/4" inputs on ch 5-6 and 9-10 are mono unless both are connected, then they switch to stereo)

15 MUTE SWITCH

Pressing this switch will silence the channel signal going to the main mix, aux send, and effects. The mute switch will not affect the signal sent to the solo system.

16 CLIP/MUTE LED

This LED normally indicates that the channel signal level is near clipping (distortion), but it also lights when mute is engaged. The clip indicator circuit monitors the signal after the gain control, after the EQ, and after the main level; because clipping can be caused by high settings of any of these controls. It illuminates at +15 dBu with a static signal (test tone), and corresponds to audible clipping with a highly dynamic signal (i.e. piano). When lit, it warns that the gain or EQ boost should be reduced. When it lights, roughly 5 dB of headroom remains. An optimized setting of input gain + EQ will result in this LED flashing briefly on the loudest peaks.

17 SIGNAL LED

The signal LED lights when the channel level reaches approximately -20 dBu. This not only indicates which channels are active, but also serves as a mini level meter. Because its illumination varies with the signal source, it is useful in identifying which channel is carrying a particular source.

18 CHANNEL LEVEL CONTROL

This is the channel's output control, which sets the signal level sent to the left and right mix and the effects send control. The gain is 0 dB (unity gain) when set to the detent at mid-rotation (12:00). 10 dB of boost is available at the max gain setting. Normal operation is to start with this knob at the detent, and set the input gain and EQ with the source playing such that normal levels are seen at the signal /clip LED's and the main meter array. As additional sources are added, it is normal to turn this knob down slightly to prevent overdriving the main mix bus.

19 SOLO SWITCH AND LED

When the Solo switch is engaged, the yellow LED lights, as does the yellow Solo LED under the main L/R meter array in the master section, indicating that the Solo system is now active. The Solo system is a separate mix bus that routes the soloed channel(s) at unity gain to the level meters for precise input level setting, and to the control room monitor and headphone outputs for critical listening to the selected source(s). When the Solo system is active, the complete mix will no longer be heard through the control room or headphones; only the soloed channel(s).

PV10AT Front Panel (channel 4)

20 MIC/LINE INPUT (CHANNEL 4 ONLY)

This input is the same as channels 1-3 unless Guitar Shape is pressed. When ELECTRIC GUITAR PRE-SHAPE is on, the 1/4" input changes to a high impedance (1 Meg Ω), like a 12AX7 vacuum tube guitar amplifier input.

21 Electric Guitar Pre-Shape

Engaging this button optimizes the on board equalization for electric guitar.

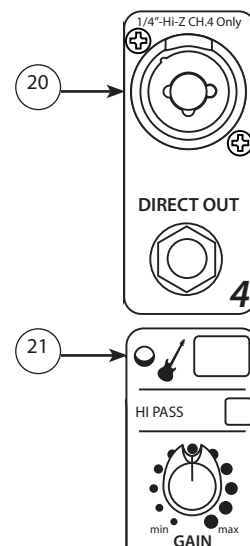

PV10AT/PV10BT Front Panel (channels 5, 6, 7 and 8)

22 3.5mm STEREO INPUT

The 3.5mm input to channel 5/6 accepts a stereo input from the output of an MP3 player, CD player, tape deck or other similar device. This input is optimized for portable handheld devices and therefore has very high sensitivity.

23 STEREO INPUTS

Channels 5 and 6 also feature 1/4" inputs. If only one jack is used, it behaves as a mono source with a pan control. When both jacks are connected, these connections serve as a stereo source with a balance control; 5 is Left and 6 is Right.

24 USB MEDIA JACK

A-type USB connector that a removable data storage device can be connected to playback music

USB PLAYBACK:

First, slide the input selection switch (27) to the USB A position. The bottom of the LCD display will say "Insert USB drive". Insert your USB drive into the USB Media Jack (24) at the top of channel 7/8. The Media Player will now enter "Folder Navigation Mode". In this mode, you can scroll through a list of all folders on the USB drive. Once you select a folder, the Media Player will enter "Song Navigation Mode" which allows you to scroll through a list of all songs contained in the selected folder. If there are no songs in the selected folder, the LCD will display "No Songs". To return to Folder Navigation Mode, scroll to the very beginning of the list and select the <FOLDERS> option.

Once a song is finished playing, the Media Player will automatically start playing the next song. Once the Media Player reaches the last song, it will automatically loop back to the beginning of the list.

25 BLUETOOTH PAIRING BUTTON AND LED

The Bluetooth Pairing Button is used to turn on/off the Bluetooth. The blue "Bluetooth Active LED" indicates the status of the Bluetooth connection. If the LED is off, the Bluetooth module is powered off. If the LED is slowly flashing, the PV mixer is not paired with any device, but is available for connection. When the LED is lit solid, the source device is properly paired to the mixer and ready to play.

The PV Mixer will remember up to 10 devices that it was previously paired with and will automatically connect to the last device with which it was paired when turned on. To clear the paired device memory, make sure Bluetooth is on and press and hold the Bluetooth Pairing Button for 5 seconds. The PV mixer will ask if you would like to clear the Bluetooth memory. Select "Y" using the Media Select knob to clear the memory. The PV mixer will go through the process of clearing the memory, which should take approximately 15 seconds.

26 RCA MEDIA INPUTS

The RCA inputs to channel 5/6 accept a stereo source such as an MP3 player, CD player, tape deck or other similar device. This input is optimized for portable handheld devices and therefore has very high sensitivity.

27 DIGITAL SOURCE SELECTOR

This switch selects between USB A (24), USB B (68), and the internal Bluetooth receiver.

28 MID CONTROL

Stereo channels' midrange is +/-20 dB @ 440Hz ; the HIGH (8) and LOW (10) controls are described above.

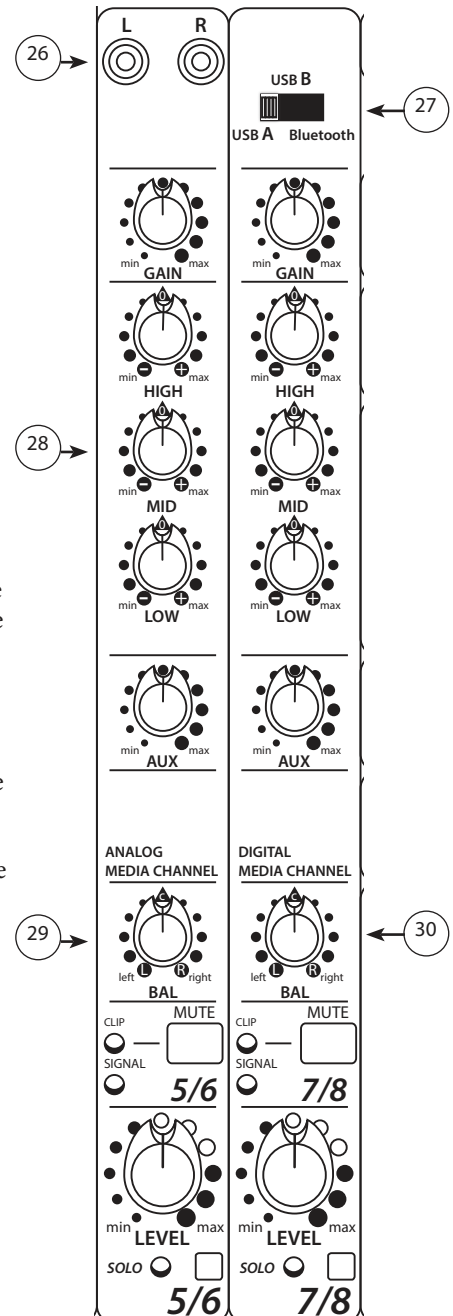
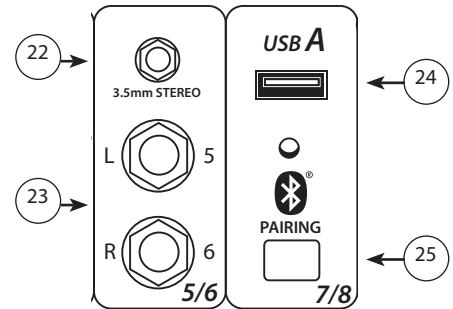

PV10AT/PV10BT Front Panel (channel 4)

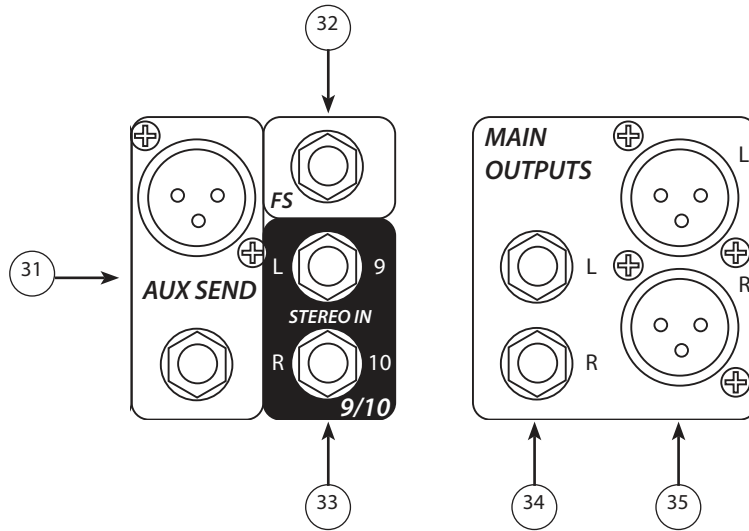

29 ANALOG BALANCE CONTROL

Controls the balance between the analog channels 5/6.

30 DIGITAL BALANCE CONTROL

Controls the balance between the digital channels 7/8.

31 AUX SEND XLR and 1/4" OUT

Ground compensated balanced output fed by the AUX SEND master level (52). The XLR is internally in parallel with the TRS. You will get better hum and noise rejection by using balanced interconnects (either XLR or TRS), but unbalanced Tip Sleeve (TS) cables will also work.

32 FOOTSWITCH

This TRS jack is designed for use with Peavey's 2 Button Special Use Momentary Footswitch, Item # 03014070. The tip of this TRS jack, switch 1, remotely actuates the EFX Mute switch. The ring of the TRS jack, switch 2, remotely turns off the Auto-Tune on AT models. This makes the use of Auto-Tune inconspicuous; by using the footswitch, your between-songs spoken banter won't be Auto-Tuned.

33 1/4" STEREO INPUTS

Channel 9 and 10 are a stereo pair of 1/4" jacks that can be used for an aux input, or effects return from an external processor. If only one jack is used, it behaves as a mono source. Once both jacks are connected, it behaves as a stereo source; 9 is Left and 10 is Right.

34 1/4" STEREO OUTPUTS

Ground compensated balanced output fed by the master L and R Faders (60). The TRS jacks are internally in parallel with the XLR's. You will get better hum and noise rejection by using balanced interconnects (either XLR or TRS), but unbalanced Tip Sleeve (TS) cables will also work.

35 XLR STEREO OUTPUTS

Ground compensated balanced output fed by the master L and R Faders (60). The XLR jacks are internally in parallel with the TRS's. You will get better hum and noise rejection by using balanced interconnects (either XLR or TRS).

PV10AT Front Panel

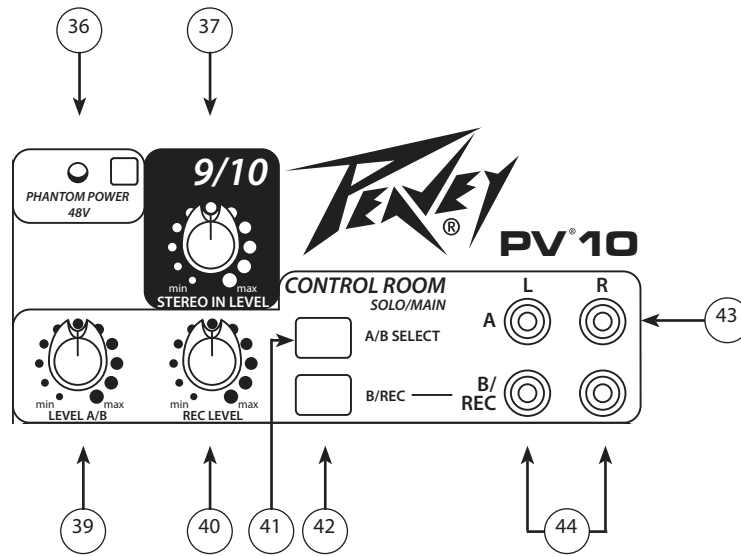

36 PHANTOM POWER

This Switch applies +48 VDC voltage to the input XLR connectors to power microphones requiring phantom power. If phantom power is used, do not connect unbalanced dynamic microphones or other devices to the XLR inputs that cannot handle this Voltage.

37 STEREO IN LEVEL 9/10

Controls the level of input jacks 9 and 10. If only one jack is connected, it is sent to both L and R. If both jacks are connected, 9 is L and 10 is R. The Aux output could be fed to an external effects processor, and these jacks could be used as the effects return. Or a second mixer could be daisy-chained in here.

39 LEVEL A/B

Controls the level of both A and B control room outputs. The active output is selected with A/B SELECT switch (41), when B/REC switch (42) is up. When B/REC switch is down, only output A is controlled.

40 REC LEVEL

When B/REC switch is down, controls the level at the B/REC outputs. **Note: When B/REC switch is up, this control is inactive.**

41 A/B SELECT

When this switch is up, output A is on and output B is off. When this switch is down, output B is on and output A is off. Use this switch to evaluate a mix on 2 different pairs of monitors, such as near field and far field monitors. By setting the level controls on both monitoring systems the same, a rapid A/B comparison can be made. Overall monitor level is controlled by LEVEL A/B. **NOTE: When the B/REC switch (42) is down, this switch is disabled, and the A output remains on at all times, fed by LEVEL A/B (39).**

42 B/REC SWITCH

Determines the function of the B/REC output. When up, B/REC jack functions as monitor B output, selected by A/B select and controlled by LEVEL A/B. When down, B/REC jack is an independent record output, with level controlled by REC LEVEL.

43 CONTROL ROOM MONITOR OUTPUT A

Connect powered monitors, or an amplifier feeding monitor speakers here. Set the volume controls on the monitors A and B to be equal when the A/B switch is toggled. The signal sent to this output is normally the Left/Right mix. The USB "To Control Room" pot (47) feeds the USB return signal to these Monitor Outputs for use in a DAW recording setup. When the Solo LED is lit (62), only the soloed source(s) will be heard. **NOTE: When the B/REC switch is down, the A/B SELECT switch becomes disabled, and this output is output is controlled by the LEVEL A/B control.**

PV10AT Front Panel

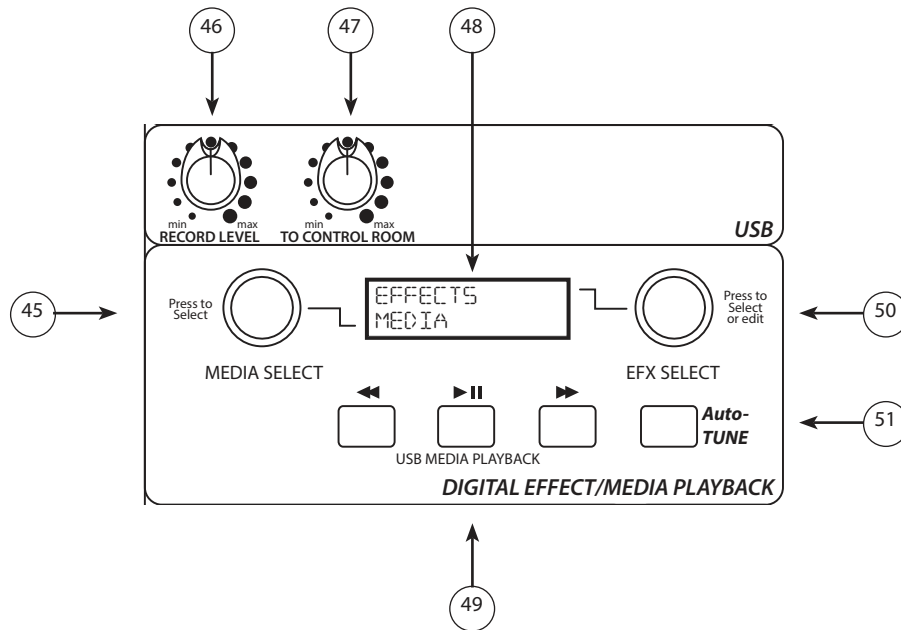

44 CONTROL ROOM MONITOR OUTPUT B / RECORD OUT

This pair of outputs can either serve as your "B" Record Monitor Output; or, with the B/REC switch (42) down, as an independently controlled Record Output. **NOTE: When the B/REC switch is down, the A/B SELECT switch becomes disabled, and this output is output is controlled by the B/REC control.**

45 USB RECORD LEVEL KNOB

Controls the level of signal sent to the USB B connector on the back of the mixer. The recommended setting is near 12:00, but a wide range is available to accommodate varying levels and sensitivities.

46 CONTROL ROOM LEVEL

Controls the level of signal returning from the USB B connector on the back of the mixer. The signal is routed to the control room and head-phone outputs, for multitrack recordings on a DAW. The recommended setting is near 12:00.

47 MEDIA AND EFFECTS LCD DISPLAY

The top row of this LCD displays the currently selected Effect and the bottom row displays the status of the MP3 Player, which can be used for navigating the folders on the USB drive or displaying the current song playing. The bottom line will also briefly display the Bluetooth status during power on, power off, and memory clearing.

48 MEDIA SELECT

Once a USB device is connected in channel 8, you can use the "Media Select" encoder to navigate through the folders/songs on the drive. Once the desired file is displayed on the screen, press the Media Select knob to cue that file. Use the controls on the mixer for play, pause, forward and reverse.

49 EFX SELECT KNOB

See detailed description on the following page.

50 MEDIA PLAYBACK CONTROLS

These controls allow you to play, pause and scroll through digital media via USB jack.

51 AUTO-TUNE ACTIVATION BUTTON (PV10AT ONLY)

Pressing this switch changes the top line of the LCD between Auto-Tune Edit Mode and EFX Edit Mode. This function is not available in the PV10BT.

PV10AT Front Panel

EFX Select Knob:

EFX Mode:

In EFX Edit Mode (see Auto-Tune Switch), the EFX Select knob is used to navigate through the EFX presets. Turning the knob changes the EFX preset in the display. The new selection will be blinking in the display; push the EFX Select knob to choose the new effect. Once the effect has been selected, you can now edit the effect. To do this, press the EFX Select knob and the display will change to the current parameter setting of the preset. Turn the EFX Select knob to edit the parameter. Press the knob again to exit EFX preset edit mode. To restore the EFX presets back to factory settings, press and hold the EFX Select knob for 5 seconds and select "Y" when prompted.

Auto-Tune Mode:

In Auto-Tune Edit Mode (see Auto-Tune Switch), the EFX Select knob is used to navigate through the Auto-Tune presets. Turning the knob changes the Auto-Tune preset in the display. The new selection will be blinking in the display; push the EFX Select knob to choose the new Auto-Tune preset.

Once the preset has been selected, you can edit the preset by pressing the EFX Select knob. The display will change to the current Key setting. Turn the EFX Select knob to change the key and push the EFX Select knob when you have chosen the key you desire. The Key setting determines which notes are enabled in the Auto-Tune process. For example, in the key of CMaj, the notes C, D, E, F, G, A, and B are enabled, and all other notes are disabled. To see which notes are enabled or disabled for each key, see the Key Table below.

Note:

If Custom Key is selected, the display will enter Custom Key Edit Mode. In this mode, you can create a custom Auto-Tune Key. Use the EFX Select knob to select the Root (labeled "RT"). This will be the note off which the custom key is based. Then use the Media Select knob to move the cursor and use the EFX Select knob to activate or deactivate the 12 notes in the key. Once you have finished editing the custom key, press the EFX Select knob to exit Custom Key Edit Mode. The mixer is capable of storing 9 different custom keys, one for each preset slot.

The scale degrees are numbered across the top, with half-steps indicated by a dash.

RT=Root or Key



*indicates the root or key is C

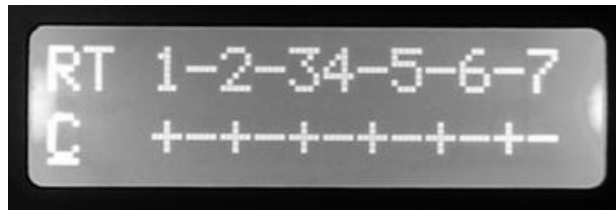

"+" indicates the note will be allowed.
"-" indicates the note will not be allowed.

By looking at the sequence of allowed and disallowed notes above, this is a whole tone scale. There are only two of those, so you can have the other one just by changing the root to C# or B.

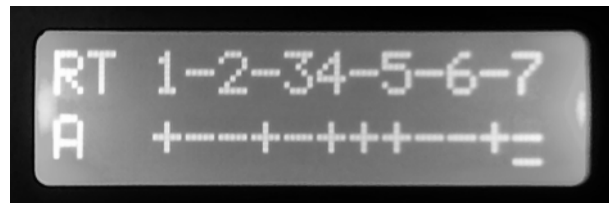

*This screen cap shows an A blues scale. You don't have to edit the whole scale to change keys - just change the root.

Once you have selected the key and pressed the EFX Select knob, the display will change to the current Speed setting. Turn the EFX Select knob to change the Speed setting. The Speed setting determines how quickly and aggressively the Auto-Tune will correct the pitch. The range for this setting is 0 to 25, where 0 is the quickest and 25 is the slowest. Push the EFX Select knob when you are done editing the speed parameter.

The display will now change to the current Detune setting. Turn the EFX Select knob to change the Detune setting. The Detune setting determines how the Auto-Tune pitch correction is calibrated. When the Detune setting is 0 cents, this means the Auto-Tune is calibrated to the standard A440, or where the note A4 equals 440 Hz. The range of the Detune setting is -64 to 63 cents, a width of 128 cents. The distance between two notes, or semitones, is 100 cents, which means that the Auto-Tune can be detuned to fit any possible environment.

Note:

Detuning the Auto-Tune can be very useful, especially when being used in conjunction with an instrument that is not easily tuned on-the-fly. For example, if a piano is accompanying Auto-Tuned vocals and the piano is slightly out of tune from the A440 standard, simply change the Detune setting in the Auto-Tune setting. This is much easier and takes much less time than having someone tune the entire piano! Also, although the Detune setting is changed in the Auto-Tune preset edit mode, this is a global parameter. This means if you change the Detune setting and then later change the Auto-Tune preset, the Detune setting will not change.

Once you have selected the appropriate Detune setting, press the EFX Select knob to exit Auto-Tune preset edit mode. To restore all Auto-Tune presets back to factory settings, press and hold the EFX Select knob for 5 seconds and select "Y" when prompted.

Note:

Preset 9 is chromatic with speed set to 7. It is recommended for general purpose, safe, easy use of Autotune, without having to adjust any settings. The slower speed setting does not produce a robotic effect on the voice, and all twelve semitones are allowed. Just remember to use footswitch #2 to bypass Autotune between songs, otherwise your speaking will be Autotuned!

Auto-Tune Key Table

Auto-Tune Key Table

Key Display Note Number (n)=

Key	0	1	2	3	4	5	6	7	8	9	10	11
Chrom C	C#	D	D#	E	F	F#	G	G#	A	A#	B	
C Maj C		D		E	F		G		A		B	
C Mnr C		D	D#		F		G	G#		A#		
C#Maj C	C#		D#		F	F#		G#		A#		
C#Mnr	C#		D#	E		F#		G#	A			B
D Maj	C#	D		E		F#	G		A			B
D Mnr C		D		E	F		G		A	A#		
D#Maj C		D	D#		F		G	G#		A#		
D#Mnr	C#		D#		F	F#		G#		A#		B
E Maj	C#		D#	E		F#		G#	A			B
E Mnr C		D		E		F#	G		A			B
F Maj C		D		E	F		G		A	A#		
F Mnr C	C#		D#		F		G	G#		A#		
F#Maj	C#		D#		F	F#		G#		A#		B
F#Mnr	C#	D		E		F#		G#	A			B
G Maj C		D		E		F#	G		A			B
G Mnr C		D	D#		F		G		A	A#		
G#Maj C	C#		D#		F		G	G#		A#		
G#Mnr	C#		D#	E		F#		G#		A#		B
A Maj	C#	D		E		F#		G#	A			B
A Mnr C		D		E	F		G		A			B
A#Maj C		D	D#		F		G		A	A#		
A#Mnr C	C#		D#		F	F#		G#		A#		
B Maj	C#		D#	E		F#		G#		A#		B
B Mnr	C#	D		E		F#	G		A			B

PV10AT Front Panel

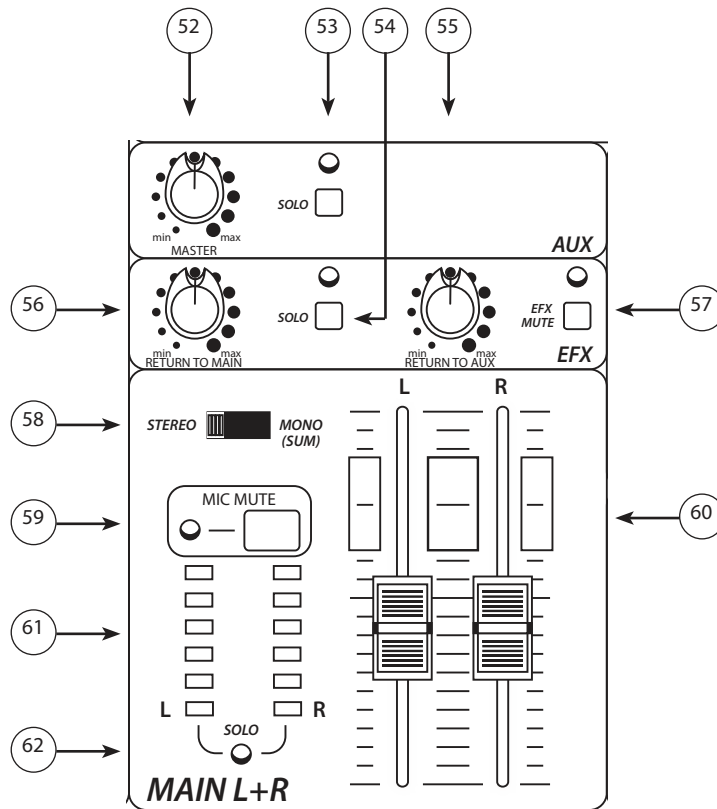

52 AUX MASTER CONTROL KNOB

Controls the overall level of the signal coming out of the Aux Output (31). This Auxiliary output is typically fed to a power amplifier to drive stage monitors so singers can hear themselves amidst amplified instruments, or to a headphone amplifier to give vocalists a monitor feed that will not be picked up by microphones while recording.

53 AUX MASTER SOLO BUTTON AND LED

Allows you to listen to just the Auxiliary mix. The setting of the AUX MASTER knob determines the level you will hear when this button is pressed.

54 EFX RETURN SOLO BUTTON AND LED

Allows you to listen to just the effects return. The setting of the Return to Main knob determines the level you will hear when this button is pressed.

55 RETURN TO AUX CONTROL KNOB

This control determines the level of the internal digital effects processor being sent to the Aux output. One possible use is to put reverb in the headphones of a vocalist, to give them a confidence boost for recording, without putting any reverb on the actual recorded track. Or in a live situation, the same can be done by feeding a delay or reverb to the monitors.

56 EFX RETURN TO MAIN

This control determines the level of the internal digital effects processor being sent to the main L and R outputs.

57 EFX MUTE BUTTON AND LED/CLIP LED

When depressed, the output of the internal digital effects is shut off. Muting the effects is an easy way to determine what a particular effect is doing to your mix. LED remains lit when EFX MUTE is engaged. When EFX MUTE is not engaged, this LED functions as a clip indicator for the internal digital effects. If the digital effects are clipping, reduce the level of the EFX SEND pots.

58 STEREO/MONO MODE SWITCH

In the mono position, the left and right buses are summed together after the faders. In this position, the L fader controls the level of the L bus, and the R fader controls the level of the R bus, allowing you to use the L and R buses as groups. For example, all vocals could be panned L and all instruments panned R. Then the L fader becomes the vocal master level and the R becomes the instruments master level.

59 MIC MUTE BUTTON AND LED

Depressing this button mutes all of the mic inputs channels (1-4) and the effects return. The media input channels are still "live". This allows you to play break music, while muting all of the microphone inputs.

60 MAIN LEVEL FADERS

The Master Faders control the levels sent to the Main Left/Right outputs (34, 35). Best results are obtained when these controls are set near the midpoint of the enclosed rectangle.

61 MAIN L+R METER ARRAY

Displays the level of the L and R outputs, or, when solo is active, displays the soloed channel(s). The top green LED corresponds to an output level of +4dBu. The red LED is a clip warning indicator. The range of the meter is from -17 dBu to + 15 dBu.

62 MAIN SOLO LED

Lights when any solo button is pushed, to indicate that the solo system is active.

63 **KOSMOS-C HIGH CONTROL**

A very selective high frequency filter with a high Q. The effect varies with source material, so some experimentation is required for optimum results.

64 **KOSMOS-C LOW CONTROL**

This Kosmos-C Low enhancement works by creating harmonics of signals in the bottom octave, where speakers are usually ineffective. The harmonics are more easily reproduced, resulting in a perception of stronger bass. The effect is source dependent; obviously a source with little energy in the bottom octave will not create booming bass.

65 **KOSMOS-C ENABLE**

Allows you to easily A/B the effects of your Kosmos Settings.

66 **HEADPHONE SOLO/MAIN LEVEL**

Controls the level of the headphones. The headphone is normally fed by the main outs, unless the solo system is active. Always start with the headphone level at "min" to avoid hearing damage.

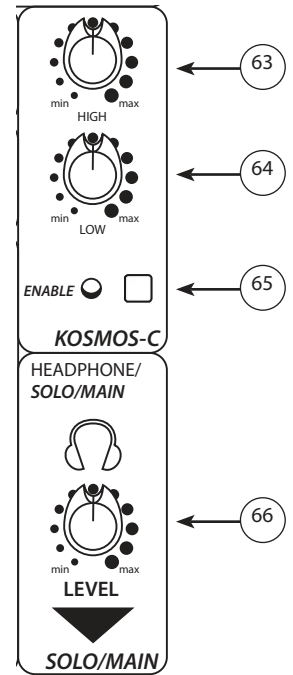

PV10AT/PV10BT

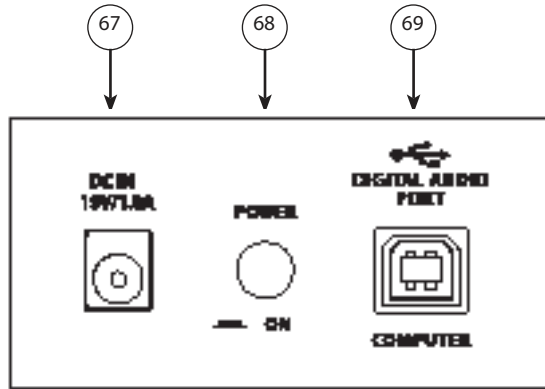

67 DC POWER INLET



Use to connect the included power supply. Be sure the power supply is connected to the PV[®]10 before connecting to a power source. Use 15VDC, 1A adapter only. Replace only with Peavey part number 30908119.

68 POWER SWITCH

This is the main power switch.

69 USB PORT TYPE B

The USB port is used to connect the PV[®] Series USB mixer to a computer for recording or playing back digital audio to/from your computer. The USB port sends the mixer's main/tape stereo out to the computer. The USB port receives digital audio from the computer; it can then be assigned through the selector switch (27) to the main left/right output, if the computer is being used for playback only. For recording, use the USB TO CONTROL ROOM control (47), to avoid creating a loop. **Compatible with Windows[®] Vista, Windows 7, & Windows 8, Mac OS X[®] 10.0 or later, and iOS devices.**

Block Diagram-PV[®]10AT & PV[®]10BT

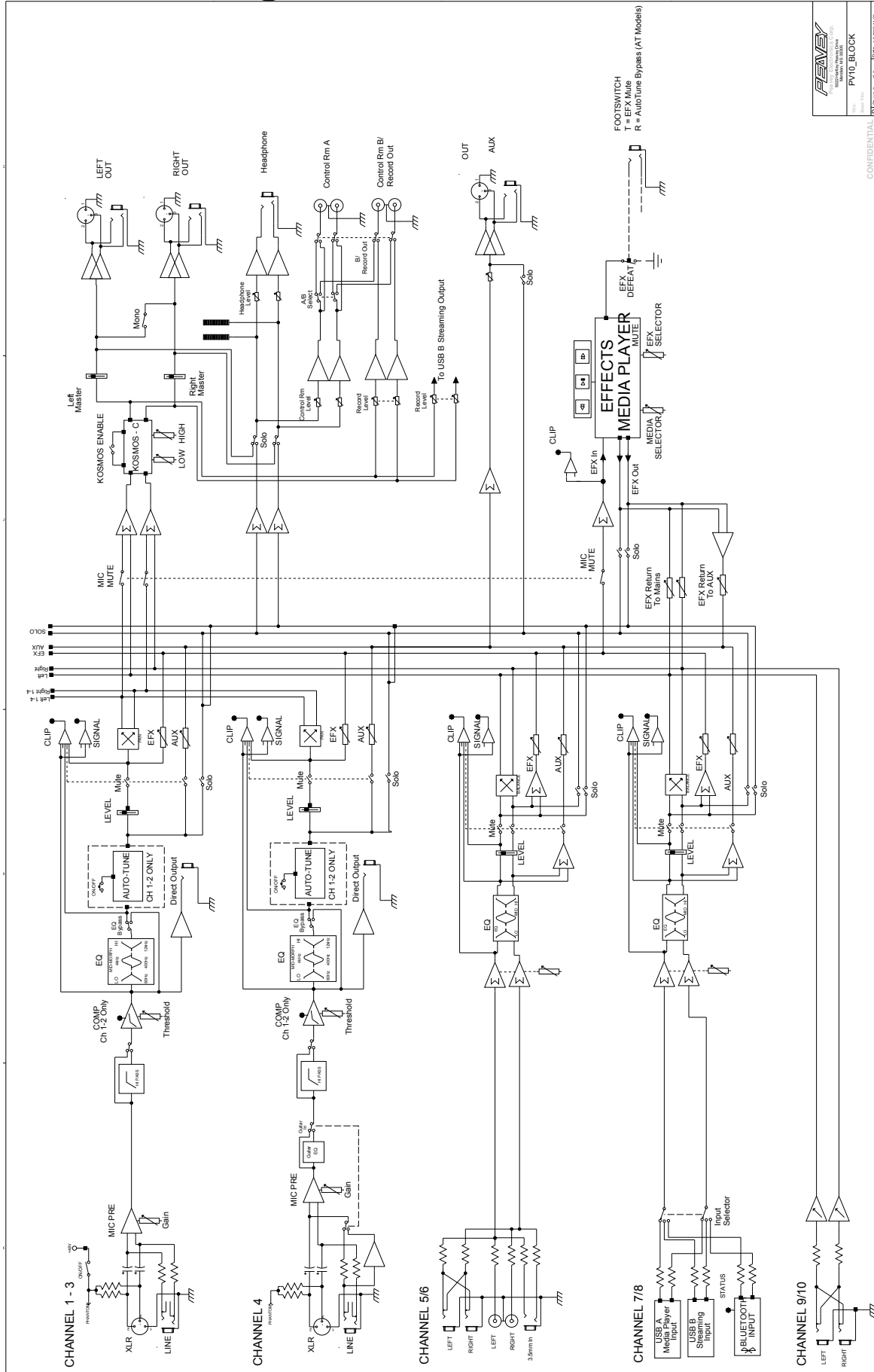

CONFIDENTIAL

PV[®]10AT & PV[®]10BT Series Specifications

Mic pre EIN = -126 dBu @ max gain with 150 ohm source

Inputs

Function	Input Z (ohms min)	Input Gain Setting	Input Levels			Bal/ Unbal	Connector
			Min**	Nominal*	Max		
Microphone (150 ohms)	2 k Ω	Max Gain (59 dB)	-71 dBu	-51 dBu	-39 dBu	Bal	XLR Pin 1 Gnd Pin 2 (+) Pin 3 (-)
		Min Gain (4 dB)	-17 dBu	+5 dBu	+16 dBu		
Line (10 k ohms)	10 k Ω	Max Gain (40 dB)	-52 dBu	-32 dBu	-20 dBu	Bal	1/4" TRS; Tip (+) Ring (-) Sleeve Ground
Line 4 TS, GTR SHAPE ON	1 Meg Ω @ \leq 200 Hz, like 12AX7 input.	Min Gain (-15 dB)	+2 dBu	+23 dBu	> +32 dBu		
Stereo Input 5/6	10 k Ω	Max Gain (18 dB)	-31 dBu	-12 dBu	+1 dBu	Unbal	1/4" TS; Tip (+) Sleeve Ground
		Nominal	-13 dBu	+6 dBu	+19 dBu		
Stereo Input 9/10	6.8 k Ω	Max Gain (18 dB)	-23 dBu	-13 dBu	+3dBu	Unbal	3.5mm; Tip=L, Ring = R, Sleeve Ground RCA: Tip (+), Sleeve Ground
		Nominal	-15 dBu	-5 dBu	+12 dBu		
3.5mm, RCA	2.8 k Ω	Max Gain (18 dB)	-43 dBu	-23 dBV	-10 dBu	Unbal	3.5mm; Tip=L, Ring = R, Sleeve Ground RCA: Tip (+), Sleeve Ground
		Nominal	-24 dBu	-5 dBu	+8 dBu		

0 dBu=0.775 V (RMS)

** Min Input Level (sensitivity) is the smallest signal that will produce nominal output (+4 dBu) with channel and master faders set for maximum gain.

* Nominal settings are defined as all controls set at 0 dB (or 50% rotation for rotary pots) except the gain adjustment pot which is as specified.

Outputs

Function	Min Load Z (ohms)	Output Levels		Bal/ Unbal	Connector
		Nominal	Max		
Main Left/Right	600	+4 dBu	+20 dBu	Bal	XLR Pin Ground Tip Pin 2 (+), Pin 3 (-) 1/4" TRS: Tip (+), Ring (-) Sleeve Ground
Effects and Monitor Sends	600	+4 dBu	+20 dBu	Bal	1/4" TRS: Tip (+), Ring (-) Sleeve Ground
Control Room	600	+4 dBu	+20 dBu	Unbal	RCA: Tip (+), Sleeve Ground
Headphone	8	+4 dBu (no load)	+20 dBu	Unbal	1/4" TRS; Tip Left, Ring Right Sleeve Ground

0 dBu=0.775 V (RMS)

Gain

Mic Input Gain Adjustment Range:	4 dB to 59 dB
Mic Input to Left/Right Balance Output	79 dB (max gain)
Line Input Gain Adjustment Range:	-16 dB to 40 dB
Line Input to Left/Right Balance Output	60 dB (max gain)
Stereo 5/6 1/4" Gain Adjustment Range:	Off to +18 dB
Stereo 5/6 1/4" to Left/Right Output	42 dB (max gain)
Stereo 5/6 3.5mm / RCA Gain Adjustment Range:	Off to +28 dB
Stereo 5/6 3.5mm / RCA to Left/Right Output:	47 dB (max gain)
Stereo 9/10 Gain Adjustment Range:	Off to +18 dB
Stereo 9/10 to Left/Right Output	28 dB (max gain)

Frequency Response

Mic Input to Left/Right Output, Max Input Gain	14 Hz to 25 kHz +0 dB/-1 dB
Mic Input to Left/Right Output, input gain 12:00	9.5 Hz to 29 kHz +0 dB/-0.8 dB

Total Harmonic Distortion

<0.006% Typical, Mic to Left/Right Output | (22 Hz to 22 kHz BW)

Hum and Noise

Output	Residual Noise	S/N Ratio (Ref: +4dBu)	Test Conditions
Master Left/Right	-97 dBu	101 dB	Master Fader Down, Channel Levels Down
	-90 dBu	94 dB	Master Fader Nominal, Channel Levels Down
	-83 dBu	87 dB	Master Fade Nominal, Channel Faders Nominal, Panned Odd Channels (left), Even Channels (right)
Monitor Send	-95 dBu	99 dB	All controls off
	-80 dBu	84 dB	All channel sends nominal, masters nominal

(Hum and noise measurements: 22 Hz to 22 kHz BW)

Equivalent Input Noise

-128 dBu (input terminated with 150 ohms, bandwidth 20 kHz)

Crosstalk/Attenuation

Adjacent Input Channels (1 kHz) >90 dB

Mute Button Attenuation (1 kHz) >90 dB

Left to Right Outputs (1 kHz) >70 dB

Channel Fader Kill (1 kHz) >85 dB

Common Mode Rejection Ratio (Mic Input)

50 dB minimum (20 Hz to 20 kHz)

70 dB typical @ 1 kHz

Meters

6 segment, peak reading (0 db = +4 dBu)

Signal/Overload Indicators

Red LED lights 5 dB below clipping

Dimensions

12.75" wide x 15.1" deep x 2.1875" high

(32.39 cm x 38.35 cm x 5.56 cm)

Weight

PV10BT: 8.22 lbs (3.73 kg)

PV10AT: 8.26 lbs (3.75 kg)

Power Requirements

100-240 VAC 50/60 Hz 15 Watts

PEAVEY ELECTRONICS CORPORATION LIMITED WARRANTY

Effective Date: 11/01/2011

What This Warranty Covers

Your Peavey Warranty covers defects in material and workmanship in Peavey products purchased and serviced in the U.S.A. and Canada.

What This Warranty Does Not Cover

The Warranty does not cover: (1) damage caused by accident, misuse, abuse, improper installation or operation, rental, product modification or neglect; (2) damage occurring during shipment; (3) damage caused by repair or service performed by persons not authorized by Peavey; (4) products on which the serial number has been altered, defaced or removed; (5) products not purchased from an Authorized Peavey Dealer.

Who This Warranty Protects

This Warranty protects only the original purchaser of the product.

How Long This Warranty Lasts

The Warranty begins on the date of purchase by the original retail purchaser. The duration of the Warranty is as follows:

Product Category	Duration
Guitars/Basses, Amplifiers, Preamplifiers, Mixers, Electronic Crossovers and Equalizers	2 years *(+ 3 years)
Drums	2 years *(+ 1 year)
Enclosures	3 years *(+ 2 years)
Digital Effect Devices and Keyboards and MIDI Controllers	1 years *(+ 1 year)
Microphones	2 years
Speaker Components (incl. Speakers, Baskets, Drivers, Diaphragm Replacement Kits and Passive Crossovers)	1 year
Tubes and Meters	90 Days
Cables	Limited Lifetime
AmpKit Link, Xport, Rockmaster Series, Strum'n Fun, RetroFire, GT & BT Series Amps	1 year
Marvel Jr. Guitar	90 Days

[* Denotes additional Warranty period applicable if optional Warranty Registration Card is completed and returned to Peavey by original retail purchaser within 90 days of purchase.]

What Peavey Will Do

We will repair or replace (at Peavey's discretion) products covered by Warranty at no charge for labor or materials. If the product or component must be shipped to Peavey for Warranty service, the consumer must pay initial shipping charges. If the repairs are covered by Warranty, Peavey will pay the return shipping charges.

How To Get Warranty Service

(1) Take the defective item and your sales receipt or other proof of date of purchase to your Authorized Peavey Dealer or Authorized Peavey Service Center.

OR

(2) Ship the defective item, prepaid, to Peavey Electronics Corporation, International Service Center, 412 Highway 11 & 80 East, Meridian, MS 39301. Include a detailed description of the problem, together with a copy of your sales receipt or other proof of date of purchase as evidence of Warranty coverage. Also provide a complete return address.

Limitation of Implied Warranties

ANY IMPLIED WARRANTIES, INCLUDING WARRANTIES OF MERCHANTABILITY AND FITNESS FOR A PARTICULAR PURPOSE, ARE LIMITED IN DURATION TO THE LENGTH OF THIS WARRANTY.

Some states do not allow limitations on how long an implied Warranty lasts, so the above limitation may not apply to you.

Exclusions of Damages

PEAVEY'S LIABILITY FOR ANY DEFECTIVE PRODUCT IS LIMITED TO THE REPAIR OR REPLACEMENT OF THE PRODUCT, AT PEAVEY'S OPTION. IF WE ELECT TO REPLACE THE PRODUCT, THE REPLACEMENT MAY BE A RECONDITIONED UNIT. PEAVEY SHALL NOT BE LIABLE FOR DAMAGES BASED ON INCONVENIENCE, LOSS OF USE, LOST PROFITS, LOST SAVINGS, DAMAGE TO ANY OTHER EQUIPMENT OR OTHER ITEMS AT THE SITE OF USE, OR ANY OTHER DAMAGES WHETHER INCIDENTAL, CONSEQUENTIAL OR OTHERWISE, EVEN IF PEAVEY HAS BEEN ADVISED OF THE POSSIBILITY OF SUCH DAMAGES.

Some states do not allow the exclusion or limitation of incidental or consequential damages, so the above limitation may not apply to you.

This Warranty gives you specific legal rights, and you may also have other rights which vary from state to state.

If you have any questions about this Warranty or services received or if you need assistance in locating an Authorized Service Center, please contact the Peavey International Service Center at (601) 483-5365.

Features and specifications are subject to change without notice.



Logo referenced in Directive 2002/96/EC Annex IV (OJ(L)37/38, 13.02.03 and defined in EN 50419: 2005)
The bar is the symbol for marking of new waste and is applied only to equipment manufactured after 13 August 2005

Optional Product Extended Warranty Registration

Give us some information and put your extended warranty into effect!

Please take a few minutes to fill out this information/survey sheet to help us get to know and serve you better.

To save time, submit your warranty registration online at www.peavey.com/support/warrantyregistration

1.

First Name _____ Initial _____ Last Name _____

Street Address _____

City _____ State/Province _____ Postal Code _____

() _____
Telephone Number _____ E-mail Address _____

() _____
Fax Number _____ Date of birth _____

Gender M F

2.

Model _____ Serial # _____

Date of Purchase _____ Price Paid _____

3.

Name of store where purchased _____

City _____ State _____

4. Top two (2) reasons why you purchased from this store/dealer:

- | | |
|---|--|
| <input type="checkbox"/> Availability of product | <input type="checkbox"/> Past favorable experience |
| <input type="checkbox"/> Friend/Relative's recommendation | <input type="checkbox"/> Best price |
| <input type="checkbox"/> Store credit card | <input type="checkbox"/> Advertised special |
| <input type="checkbox"/> Knowledgeable staff | <input type="checkbox"/> Convenient location |
| <input type="checkbox"/> Availability of lessons | <input type="checkbox"/> Received as a gift |
| <input type="checkbox"/> Technical instruction | <input type="checkbox"/> Other _____ |

5. Where do you most often shop for music and sound products?

- | | |
|---|---|
| <input type="checkbox"/> Independent retailer | <input type="checkbox"/> Newspaper ads |
| <input type="checkbox"/> Mass market retailer | <input type="checkbox"/> Internet/Web sites |
| <input type="checkbox"/> Mail order magazines | <input type="checkbox"/> Other _____ |

6. What two (2) factors most influenced your purchase of this product?

- | | |
|--|---|
| <input type="checkbox"/> Peavey brand name | <input type="checkbox"/> Product appearance |
| <input type="checkbox"/> Craftsmanship | <input type="checkbox"/> Durability |
| <input type="checkbox"/> Features for price | <input type="checkbox"/> Prior experience with Peavey |
| <input type="checkbox"/> Bundled accessories | <input type="checkbox"/> Packaging |
| <input type="checkbox"/> Sound quality | <input type="checkbox"/> Other _____ |

15. In your opinion, what could Peavey do to improve its products and/or service? Please use the space below to tell us your answer.

7. How did you learn about this Peavey product? (select best answer)

- | | |
|---|---|
| <input type="checkbox"/> Magazine review | <input type="checkbox"/> Teacher's recommendation |
| <input type="checkbox"/> Newspaper review | <input type="checkbox"/> Catalog or flyer |
| <input type="checkbox"/> Radio advertisement | <input type="checkbox"/> Saw in store |
| <input type="checkbox"/> Advertised special | <input type="checkbox"/> Use by professional |
| <input type="checkbox"/> Friend/Relative's recommendation | <input type="checkbox"/> Other _____ |
| <input type="checkbox"/> Salesperson's recommendation | |

8. Which other brands/models did you consider?

9. How would you describe your level of musicianship/technical expertise?

- Beginner - Never played or taken less than one (1) year of lessons
- Intermediate - One (1) to five (5) years of lessons or playing
- Advanced - More than five (5) years of lessons or playing; play professionally

10. Education: (select best answer)

- High school
- Some college
- Completed college
- Graduate school

11. Which best describe your family income? (select best answer)

- | | |
|--|--|
| <input type="checkbox"/> Under \$15,000 | <input type="checkbox"/> \$75,000 - \$99,999 |
| <input type="checkbox"/> \$15,000 - \$24,999 | <input type="checkbox"/> \$100,000 - \$149,999 |
| <input type="checkbox"/> \$25,000 - \$34,999 | <input type="checkbox"/> Over - \$150,000 |
| <input type="checkbox"/> \$35,000 - \$49,999 | |
| <input type="checkbox"/> \$50,000 - \$74,999 | |

12. Which of the following is your primary source of information on musical products: (select best answer)

- | | |
|-------------------------------------|---|
| <input type="checkbox"/> Television | <input type="checkbox"/> Mail order catalogs |
| <input type="checkbox"/> Radio | <input type="checkbox"/> Direct mail |
| <input type="checkbox"/> Internet | <input type="checkbox"/> Literature from manufacturer |
| <input type="checkbox"/> Newspaper | <input type="checkbox"/> Other _____ |
| <input type="checkbox"/> Magazines | |

13. What is your main motivation for buying new equipment?

- | | |
|--|--|
| <input type="checkbox"/> Replacing old product | <input type="checkbox"/> Impulse |
| <input type="checkbox"/> Want new and leading edge equipment | <input type="checkbox"/> Need for improved performance |
| <input type="checkbox"/> Fullfill a specific need | <input type="checkbox"/> New technology |
| <input type="checkbox"/> Supplement existing products | <input type="checkbox"/> Availability of product |
| <input type="checkbox"/> Value | <input type="checkbox"/> Other _____ |

14. Please list your three most frequently visited Web sites.

1. http:// _____
2. http:// _____
3. http:// _____



FROM:

**Peavey Electronics
Corporation**
Attn: Warranty Department
P.O. Box 5108
Meridian, Ms 39302-5108



Place
Postage
Here

