

MH140CKT, MH185CKT, MH220CKT

OPERATING INSTRUCTIONS AND OWNER'S MANUAL



FOR QUESTIONS AND CONCERNS, CONTACT US AT

Allparts Equipment &
Accessories Inc.

www.allpartsinc.com

Call Us: 1-269-685-4123

Text Us: 1-269-447-0412

NEVER LEAVE THE HEATER UNATTENDED WHILE BURNING!

OPERATING INSTRUCTIONS AND OWNER'S MANUAL



KEROSENE FORCED-AIR HEATER

Model #

MH140CKT
MH185CKT
MH220CKT

READ INSTRUCTIONS CAREFULLY: Read and follow all instructions. Place instructions in a safe place for future reference. Do not allow anyone who has not read these instructions to assemble, light, adjust or operate the heater.



SCAN THE QR CODE OR GO TO
WWW.MRHEATER.COM/WARRANTY-REGISTRATION
TO REGISTER YOUR MR. HEATER® PRODUCTS.
SCANNEZ LE CODE QR OU ALLEZ SUR
WWW.MRHEATER.COM/WARRANTY-REGISTRATION
POUR ENREGISTRER VOS PRODUITS MR. HEATER®
ESCANEE EL CÓDIGO QR O VISITE
WWW.MRHEATER.COM/WARRANTY-REGISTRATION
PARA REGISTRAR SUS PRODUCTOS MR. HEATER®



⚠ WARNING: If the information in this manual is not followed exactly, a fire or explosion may result causing property damage, personal injury or loss of life.

- Do not store or use gasoline or other flammable vapors and liquids in the vicinity of this or any other appliance.
- Service must be performed by a qualified service agency.

This is an unvented portable heater. It uses air (oxygen) from the area in which it is used. Adequate combustion and ventilation air must be provided. Refer to page 3.

WARNING:

⚠ YOUR SAFETY IS IMPORTANT TO YOU AND TO OTHERS, SO PLEASE READ THESE INSTRUCTIONS BEFORE YOU OPERATE THIS HEATER.

GENERAL HAZARD WARNING:

- ⚠ FAILURE TO COMPLY WITH THE PRECAUTIONS AND INSTRUCTIONS PROVIDED WITH THIS HEATER, CAN RESULT IN DEATH, SERIOUS BODILY INJURY AND PROPERTY LOSS OR DAMAGE FROM HAZARDS OF FIRE, EXPLOSION, BURN, ASPHYXIATION, CARBON MONOXIDE POISONING, AND/OR ELECTRICAL SHOCK.
- ⚠ ONLY PERSONS WHO CAN UNDERSTAND AND FOLLOW THE INSTRUCTIONS SHOULD USE OR SERVICE THIS HEATER.
- ⚠ IF YOU NEED ASSISTANCE OR HEATER INFORMATION SUCH AS AN INSTRUCTIONS MANUAL, LABELS, ETC. CONTACT THE MANUFACTURER.

WARNING:

⚠ **CARBON MONOXIDE CAN KILL YOU**
USING A PORTABLE HEATER IN AN ENCLOSED AREA CAN PRODUCE DEADLY CARBON MONOXIDE.

WARNING:

⚠ NOT FOR HOME OR RECREATIONAL VEHICLE USE

WARNING:

⚠ FIRE, BURN, INHALATION, AND EXPLOSION HAZARD. KEEP SOLID COMBUSTIBLES, SUCH AS BUILDING MATERIALS, PAPER OR CARDBOARD, A SAFE DISTANCE AWAY FROM THE HEATER AS RECOMMENDED BY THE INSTRUCTIONS NEVER USE THE HEATER IN SPACES WHICH DO OR MAY CONTAIN VOLATILE OR AIRBORNE COMBUSTIBLES, OR PRODUCTS SUCH AS GASOLINE, SOLVENTS, PAINT THINNER, DUST PARTICLES OR UNKNOWN CHEMICALS.

WARNING:

The State of California requires the following warning:
COMBUSTION BY-PRODUCTS PRODUCED WHEN USING THIS PRODUCT CONTAIN CARBON MONOXIDE, A CHEMICAL KNOWN TO THE STATE OF CALIFORNIA TO CAUSE CANCER AND BIRTH DEFECTS (OR OTHER REPRODUCTIVE HARM).

THIS PRODUCT CONTAINS CHEMICALS KNOWN TO THE STATE OF CALIFORNIA TO CAUSE CANCER AND BIRTH DEFECTS OR OTHER REPRODUCTIVE HARM.

WARNING:

- DO NOT USE GASOLINE, NAPHTHA OR VOLATILE FUELS.
- STOP HEATER BEFORE ADDING FUELS.
- ALWAYS FILL OUTDOORS AWAY FROM OPEN FLAME.
- DO NOT USE EXTERNAL FUEL SOURCE.
- DO NOT OPERATE HEATER WHERE FLAMMABLE LIQUIDS OR VAPORS MAY BE PRESENT.
- DO NOT START HEATER WHEN CHAMBER IS HOT.
- DO NOT START HEATER WHEN EXCESS FUEL HAS ACCUMULATED IN THE CHAMBER.
- DO NOT PLACE COOKING UTENSILS ON TOP OF THE HEATER.
- PLUG ELECTRICAL CORD INTO A PROPERLY GROUNDED THREE-PRONG RECEPTACLE.

CONTENTS

WARNINGS.....	2
HEATER SPECIFICATIONS.....	3
OPERATING PRECAUTIONS.....	3
SAFETY PRECAUTIONS.....	3
OPERATING INSTRUCTIONS.....	3
MAINTENANCE, STORAGE AND SERVICE.....	4
TROUBLESHOOTING.....	6
WIRING DIAGRAM.....	7
PARTS LIST.....	8
EXPLODED VIEW.....	9
WARRANTY.....	10
INSTRUCTIONS FOR ORDERING PARTS.....	10



LANGUAGES

► ENGLISH.....	1-10
FRENCH.....	1-10
SPANISH.....	1-12

SPECIFICATIONS

CAUTION: CSA certified for use with only No. 1-K kerosene fuel.

Factory Tested: Kerosene, Diesel #1 and #2, Fuel Oil #1 and #2, JP8 (Jet A Fuel), Biodiesel blends B2, B5, B10, and B20

Model	MH140CKT	MH185CKT	MH220CKT
Burn Rate:	140,000 Btu/hr (41 kW)	185,000 Btu/hr (54.2 kW)	220,000 Btu/hr (64.5 kW)
Fuel Rate:	1.1 gal/hr (4.2 L/hr)	1.4 gal/hr (5.3 L/hr)	1.7 gal./hr (6.4 L/hr)
Electrical Input:	115V, 60Hz, 1.8 A	115V, 60Hz, 2.3 A	115V, 60Hz, 2.5 A
Line Protection:	8 amps	8 amps	8 amps
Min. Operating Voltage:	110V	110V	110V
Pressure Setting:	6.0 psig (41.4 kPa)	7.5 psig (51.7 kPa)	7.8 psig (53.8 kPa)
Max. Outlet Temperature:	1300°F (704°C)	1300°F (704°C)	1300°F (704°C)
Fuel Tank Capacity:	8 gallons (32 L)	13 gallons (51 L)	13 gallons (51 L)
Ignition:	Direct Spark, Continuous	Direct Spark, Continuous	Direct Spark, Continuous
Spark Generator:	Igniter 16.5 kV, 0.02 mA	Igniter 16.5 kV, 0.02 mA	Igniter 16.5 kV, 0.02 mA
Primary Safety Control:	Solid State Control	Solid State Control	Solid State Control
Certification:			

OPERATING PRECAUTIONS

This is a kerosene, direct-fired, forced air heater. It's intended use is primarily temporary heating of buildings under construction, alteration or repair.

Direct-Fired means that all of the combustion products enter the heated space. Even though this heater operates very close to 100 percent combustion efficiency, it still produces small amounts of carbon monoxide. Carbon monoxide (called CO) is toxic. CO can build up in a heated space and failure to provide adequate ventilation could result in death. The symptoms of inadequate ventilation are:

- headache
- dizziness
- burning eyes and nose
- nausea
- dry mouth or sore throat

Be sure to follow advice about ventilation in the Safety Precautions section.

Forced Air means that a blower or fan pushes the air through the heater. Proper combustion depends upon this air flow; therefore, the heater must not be revised, modified or operated with parts removed or missing. Likewise, safety systems must not be circumvented or modified in order to operate the heater.

When the heater is to be operated in the presence of other people the user is responsible for properly acquainting those present with the safety precautions and instructions, and of the hazards involved.

SAFETY PRECAUTIONS

1. Recommended for use with No.1-K kerosene fuel. Factory tested for use with No.2-K kerosene, No.1 or No.2 Diesel, No.1 or No.2 fuel oil, JP8 Jet A fuel and Biodiesel blends B2, B5, B10, and B20 may be used as well. Never use gasoline, oil drained from crank cases, naphtha, paint thinners, alcohol or any other highly flammable fuels.
2. Check the heater thoroughly for damage. DO NOT operate a damaged heater.

3. DO NOT modify the heater or operate a heater which has been modified from its original condition.
4. Suitable for either outdoor or indoor use where adequate ventilation is provided. Never use in areas normally for habitation. Not for use where exposed to weather.
5. Use in well ventilated areas, provide at least 2 sq. ft. (0.19 sq. m.) of opening near the floor and 2 sq. ft. (0.19 sq. m.) near the ceiling directly to outdoors. Increase air openings as marked for each additional heater.
6. Always keep combustibles, like paper and wood at least 8 ft. (2.4 m) from the heater outlet and 3 ft. (1.0 m) from the top, sides and inlet. Locate 10 ft. (3.0 m) from canvas or plastic coverings and secure them to prevent flapping movement.
7. Caution: Due to the high surface and exhaust temperatures, adults and children must observe clearances to avoid burns or clothing ignition. Do Not Touch. Keep children, clothing, and combustible away.
8. Install the heater such that it is not directly exposed to water spray, rain and / or water.
9. Never use in areas normally for habitation and /or where children may be present.
10. Operate only on a stable, level surface.
11. Do not use with duct work. Do not restrict inlet or exit.
12. Use only with electrical power specified. The electrical connection and grounding must comply with National Electrical Code – ANSI/NFPA 70 (USA) and CSA C22.1 Canadian Electrical Code, Part 1 (Canada).
13. Use only a properly grounded 3-prong receptacle or extension cord.
14. Do not move, handle, or service while hot or in operation.
15. Use only in accordance with local, state (provincial) or national requirements, ordinances and codes.

NEVER LEAVE THE HEATER UNATTENDED WHILE BURNING!

OPERATING INSTRUCTIONS

UNPACKING

1. Remove heater from carton.
2. Remove all protective material which may have been applied to the heater for shipment.
3. Check the heater for possible shipping damage. If any damage is found immediately contact the manufacturer at 800-251-0001.

ASSEMBLY

Wheels, axle, and handles are found in the shipping carton along with mounting hardware.

1. Handles come pre-assembled on the tank. The transport handle and support foot simply snap into place.
2. To assemble the wheels, first Install one of the large lock nut onto the end of the axle.
3. Slide one wheel onto the axle next to the nut, then one spacer.
4. Slide the partially assembled axle through the wheel support frame.
5. Slide the spacer onto the axle next to the wheel support.
6. Slide the wheel, then large last large lock nut onto the axle. Using two adjustable wrenches hold both nuts and tighten. **DO NOT OVERTIGHTEN.**

PREPARING FOR OPERATION

1. Check the heater for possible shipping damage. If any is found, immediately contact the manufacturer at 800-251-0001.
2. Follow all of the "Precautions".
3. Fill the fuel tank with clean kerosene. In extremely cold weather, condensation may develop in the tank and it is recommended that a tablespoon of de-icer be added for each gallon (3.78 Liters) of fuel in the tank. When filling the heater, use at least 2 gallons (7.57 liters) of fuel. Be sure heater is level and do not overfill. Use a funnel or can with a long fill spout.

IMPORTANT: Before filling fuel tank the first time or after extended storage periods, drain the fuel tank of any moisture or condensation.

4. Locate heater at a safe distance from combustible materials.

HEATER START UP

1. Turn thermostat to lowest setting, and make sure "On/Off" switch is "Off". Plug the heater into a grounded 115V, 60 Hz, 1 Ø outlet. Turn thermostat to highest setting. Start heater by pushing toggle switch to "On" position (light signifies switch is in "ON" position). Adjust thermostat to desired setting. Heater will cycle on/off as heat is required.

EXTENSION CORD REQUIREMENTS: Up to 100' (30.5m) use 16 awg. conductor. 101' - 200' (30.5 - 61.0m) use 14 awg. conductor.

Notes:

- In cold weather (below 10 °F), starting may be improved by holding a finger over the vent hole of the pump adjustment screw cap until the heater starts.

- This unit is equipped with an interrupt circuit. The reset is integrated into the "On/Off" switch. If the unit does not start, toggle the switch to "Off", wait 5 min. and toggle the switch to "On".

HEATER SHUT DOWN

1. Push "On/Off" switch to "Off" position. For extended shutdown, unplug heater from power source.

RESTART AFTER SAFETY SHUTDOWN

1. Toggle switch to "OFF" position, wait 5 minutes. Restart.

MAINTENANCE AND STORAGE

!WARNING: To prevent personal injury, unplug the heater from the wall outlet before servicing.

For maximum efficiency and trouble-free service, make the following periodic maintenance, cleaning and inspections.

ADJUSTING PUMP PRESSURE



Due to varying fuel viscosities and normal component wear the pump pressure on this heater may need to be adjusted.

FUEL PRESSURE ADJUSTMENT SCREW
(located at the rear of the heater)



ADJUSTMENT PROCEDURE

1. Fill fuel tank.
2. Start heater.
3. Locate the pressure adjustment screw and pressure tap, pictured above, located on the back of the power pack assembly and accessible by the handle of the heater.
4. Remove and the rubber cap over the fuel pressure adjustment screw.
5. Using a flat bladed screw driver, turn the pump pressure adjustment screw:

- clockwise  to increase pump pressure
- counter-clockwise  to decrease pump pressure

By using the installed pressure gauge you may quantitatively calibrate the pressure. The manufacturer's recommended pump pressures are in the specifications chart on page 3.

6. The desired qualitative burner characteristics are that the nose cone in the combustion chamber should be cherry red with no dark spots and the flame should not extend beyond the nose cone.

IMPROPER PRESSURE ADJUSTMENT

Problem: Heater does not have a strong consistent flame.
Heater smokes and spits raw fuel.
Nose cone does not get cherry red.

Adjustment: Pump pressure is too low.
Turn adjustment screw clockwise to increase pump pressure.

Problem: Flame extends beyond the end of the heater.

Adjustment: Pump pressure is too high.
Turn adjustment screw counter clockwise to decrease pump pressure.

DAILY SCHEDULE

1. **GENERAL.** Make general visual inspection of heater for loose or damaged parts. Check nuts and bolts to insure against looseness caused by vibration or rough handling. Damaged parts should be repaired or replaced before using heater again. Check heater operation to be sure it is operating normally (See "Servicing" section for description of normal operation).
2. **FILTERS.** Dirty air or fuel filters will cause an imbalance in the air-fuel mixture. The best indication that this condition exists is an increase in odors or difficulty getting your heater to ignite. This heater should never be operated without the filters in place. If required, clean filters as described under "500 Hours" and "Annual Schedules".

500 HOUR SCHEDULE

1. **AIR INTAKE FILTER.** Remove and wash the filter element with a mild detergent, dry thoroughly and replace. Do not oil the filter element. If your heater is used where there is considerable dust or dirt, clean as often as necessary (approximately every 50 hrs.).
2. **REMOVE DUST.** Clean heater twice a season (more often under dusty conditions). Remove accumulated dust from the transformer, burner, motor and fan blades with compressed air. Wipe area clean with a clean dry cloth. Inspect area to ensure all foreign materials are removed, especially around the burner and combustion area.
3. **CAD CELL.** Clean the glass portion of the cad cell with a soft dry cloth.
4. **NOZZLE.** Accumulation of dirt from fuel and carbon from the compressor vanes will eventually fill up the passages in the nozzle, resulting in reduction of fuel and air flow. Pressure will gradually increase giving improper fuel-air mixture and excess odor and smoke. If this occurs, replace the fuel nozzle.
5. **FUEL TANK.** Clean twice a season (during frequently used periods, clean twice a month). Drain and flush the fuel tank with clean fuel oil.

ANNUAL SCHEDULE

1. **AIR OUTPUT FILTER.** Remove the air output filter and tap the contaminated side gently on a solid object to remove contaminants. Compressed air or liquids should not be used to clean this filter. Reinstall cleaned filter in filter body in the same position as it was when removed. If the filter appears extremely dirty, replace it with a new filter of the same type. When replacing the filter cover, be sure the gasket is firmly in place and the screws in the filter cover are tight to prevent air leaks.
2. **FUEL FILTER.** Remove the fuel filter from fuel line and direct compressed air through the filter in the opposite direction of fuel flow. Safety glasses should be worn when using compressed air.
3. **AIR AND FUEL LINES.** If the air or fuel lines are removed during cleaning, be sure all connections are tight before operating unit.

STORAGE

Store the heater in a dry location free from fumes or dust. At the end of each heating season, clean the heater as described in the MAINTENANCE section. Drain and flush the fuel tank with clean fuel. The manufacturer recommends completely filling the tank with fuel for extended storage to minimize condensation inside the tank.

It is recommended to only store kerosene in containers that are marked "KEROSENE".

SERVICING

A hazardous condition may result if a heater is used that has been modified or is not functioning properly.

When the heater is working normally:

- * The flame is contained within the heater.
- * The flame is essentially yellow.
- * There is no strong disagreeable odor, eye burning or other physical discomfort.
- * There is no smoke or soot internal or external to the heater.
- * There are no unplanned or unexplained shutdowns of the heater.

TROUBLE SHOOTING

SYMPTOM	TROUBLE SHOOTING
Heater shuts off after continued operation - High Limit Switch	1) Make sure heater is cooled off, toggle switch to "OFF" position, wait 5 minutes and retry.
Heater sparks, calling for flame, but no or slow fan/motor operation	1) Check wiring to motor (per wiring schematic in manual). 2) Make sure that the pressure gauge is in place and not damaged. 3) Adjust pressure for proper heater operation per manual. 4) With heater disconnected from AC source, rotate fan clockwise to verify motor is free. 5) Remove air filter housing from motor and inspect the pump rotor for damage. If damaged, replace rotor assembly. 6) If wiring is correct, pump rotor is okay, and motor is not rotating freely, replace motor or power-pack assembly. 7) If problem persists, replace oil flame control assembly. 8) Check if the ignition electrode is sparking correctly between the probes and not to the combustion cylinder. 9) Check the cad cell for continuity.
Heater does not spark	1) Check length and gage of extension cord for proper amp draw. (Check requirements on page 4.) 2) Check wiring to ignition electrode (per wiring schematic in manual). 3) Check gap between ignition electrode probes (3.5 mm). 4) Still no spark, replace igniter assembly. 5) Replace control board.
Abnormal Motor Operation - Motor overheats or Stops	1) Motor speed too low (Motor should operate at 3450rpm) - Replace motor. 2) With heater disconnected from AC source, rotate fan clockwise to verify motor is free. 3) Remove air filter housing from motor and inspect the pump rotor for damage. If damaged, replace rotor assembly. 4) If wiring is correct, pump rotor is okay, and motor is not rotating freely, replace motor or power-pack assembly. 5) Replace control board.
Unable to Detect Flame	1) Check wiring to cad cell (photo cell per wiring schematic in manual). 2) Clean cad cell eye. a) Slide cad cell out of cad cell holder. b) Push the cad cell out of the black rubber cad cell housing by pushing on the 2 black wires. c) Clean the cad cell eye with a soft cloth and rubbing alcohol. d) Pull the cad cell back into the cad cell housing and reinstall into holder. e) Test heater. 3) If the heater still does not operate, replace cad cell. 4) If the heater still does not operate, replace control board.
Flame Control Failure	1) Check wiring in heater (per wiring schematic in manual). 2) Replace oil flame control assembly.

WIRING DIAGRAM

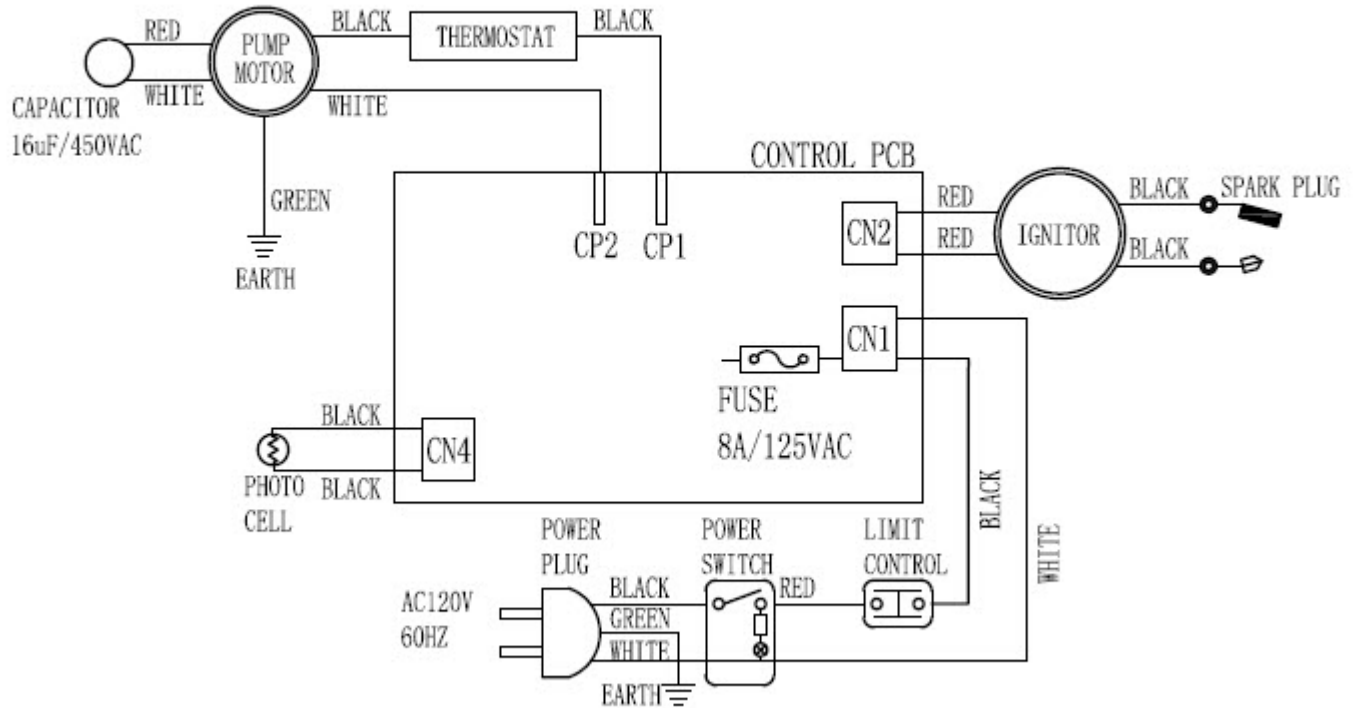

The parts lists and wiring diagram show the heater as it was constructed. Do not use a heater which is different from that shown. Heater performance is effected by air pressure setting. If there is any uncertainty about the air pressure setting, have it checked.

A heater which is not working right must be repaired, but only by a trained, experienced service person.

PARTS LIST

#	140K	185K	220K	DESCRIPTION
1	n/a	n/a	n/a	Front Upper Shell
2	28896	28896	28896	Ignition Electrode
3	n/a	n/a	n/a	Rear Upper Shell
4	n/a	n/a	n/a	Air Inlet Plate
5	28897	28897	28897	Photocell Assembly
6	n/a	n/a	n/a	Air Deflector Plate
7	28898	28899	28900	Nozzle Assembly
8	n/a	n/a	n/a	Fan Blade
9	28901	28902	28902	Powerpack Assembly
10	n/a	n/a	n/a	Rear Plastic Guard
11	28903	28904	28904	Handle
12	n/a	n/a	n/a	On/Off Switch
13	28905	28905	28905	Control Board
14	28906	28906	28906	Fuel Filter
15	n/a	n/a	n/a	Power Cord
16	n/a	n/a	n/a	Fuel Cap
17	28907	28907	28907	Ignition Module
18	n/a	n/a	n/a	Rear Handle Mount
19	n/a	n/a	n/a	Fuel Gauge Assembly
20	n/a	n/a	n/a	Rear Base Mount
21	28908	28908	28908	Support Base
22	n/a	n/a	n/a	Fuel Tank Plug
23	28909	28910	28910	Wheel Axle (w/Hardware)
24	n/a	n/a	n/a	Fuel Tank
25	28911	28911	28911	Wheel
26	n/a	n/a	n/a	Wheel Support Bracket
27	28921	28921	28921	Thermostat Switch Assembly
28	n/a	n/a	n/a	Control Side Panel (Left)
29	n/a	n/a	n/a	Fuel Side Panel (Right)
30	n/a	n/a	n/a	Lower Shell
31	28912	28913	28913	High Limit Switch Assembly
32	28914	28915	28916	Combustion Chamber
33	n/a	n/a	n/a	Radiation Shield Assembly
*	28917	28917	28917	Rotor Kit
*	28918	28918	28918	Gasket Kit
*	28919	28919	28919	Pump Adjustment Kit

* Not Shown

NEVER LEAVE THE HEATER UNATTENDED WHILE BURNING!

Kerosene Forced Air Heater • Models MH140CKT, MH185CKT, MH220CKT

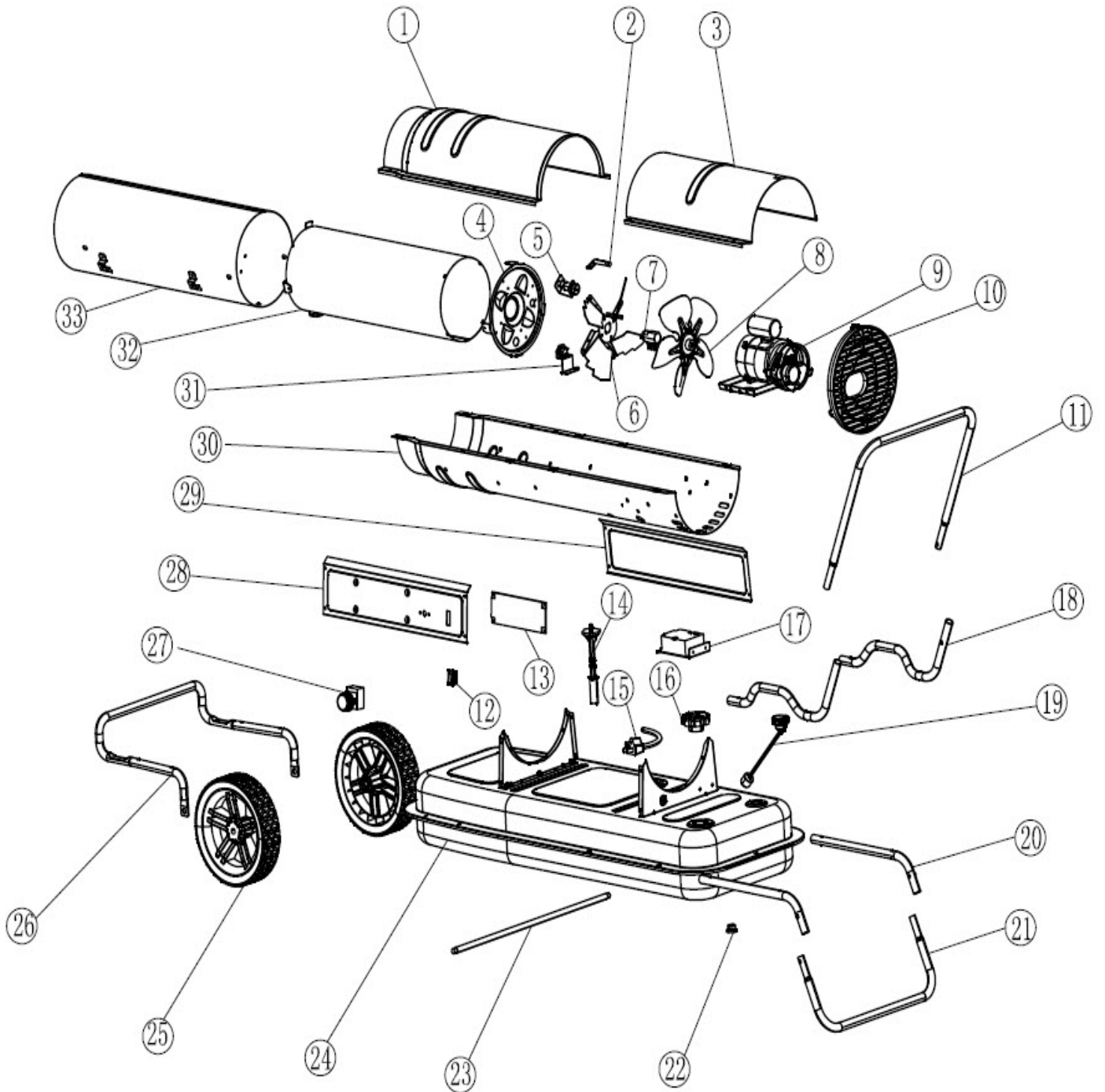

NEVER LEAVE THE HEATER UNATTENDED WHILE BURNING!



OPERATING INSTRUCTIONS AND OWNER'S MANUAL

Model #

MH140CKT
MH185CKT
MH220CKT



WARNING:

USE ONLY MANUFACTURER'S REPLACEMENT PARTS. USE OF ANY OTHER PARTS COULD CAUSE INJURY OR DEATH. REPLACEMENT PARTS ARE ONLY AVAILABLE DIRECT FROM THE FACTORY AND MUST BE INSTALLED BY A QUALIFIED SERVICE AGENCY.

PARTS ORDERING INFORMATION:

PURCHASING: Accessories may be purchased at any Mr. Heater local dealer or direct from the factory

FOR INFORMATION REGARDING SERVICE

Please call Toll-Free 800-251-0001
www.mrheater.com

Our office hours are 8:00 AM – 5:00 PM, EST, Monday through Friday.

Please include the model number, date of purchase, and description of problem in all communication.

LIMITED WARRANTY

Enerco Group, Inc. warrants its heaters and accessories to be free from defects in material and workmanship for a period of 1 year from date of purchase. Enerco Group, Inc. will repair or replace this product free of charge if it has been proven to be defective within the 1-year period, and is returned at customer expense with proof of purchase to Enerco Group, Inc. within the warranty period.

Some states do not allow the exclusion or limitation of incidental or consequential damages, so the above limitation or exclusion may not apply to you. This Warranty gives you specific legal rights, and you may have other rights which vary from state to state.

Enerco Group, Inc. reserves the right to make changes at any time, without notice or obligation, in colors, specifications, accessories, materials and models.

ENERCO GROUP, INC., 4560 W. 160TH ST., CLEVELAND, OHIO 44135 • 800-251-0001
© 2024, Mr. Heater/Mr. Heater. All rights reserved



UL733 Fifth Edition, CSA B140.8-1967