

SG

MAVERICK

QBiL



Startup Guide

En Vol 1. 151000-006 SG



Thank you for selecting this Maverick RC product!

HAVE FUN! But please read this first!!

We know you will have great fun with your model, but to get the best from your purchase, please read this information before operating your model.



Safety precautions

WARNING! THIS IS NOT A TOY

This product is an authentic hobby-grade radio-controlled vehicle (RC vehicle) and not a toy.

Please read the enclosed instructions carefully and follow all product warnings for all accessories used with this product, including batteries, chargers, tools, adhesives, electronics, and cleaning materials.

This model may require some assembly and will need regular maintenance.

Prior experience with RC models is recommended.

If you are new to radio-controlled vehicles, please ask an experienced hobbyist or retailer for advice.

- Never connect the drive battery with reversed polarity or attempt to disassemble the battery. Incorrect handling can cause short circuits or fire and is extremely dangerous.
- If you are using rechargeable batteries for the transmitter, always use a compatible charger for that battery type.
- Do not operate, display, or test this product on public roads, in crowded places, or near people or animals. Always make sure others are aware you are using this model to prevent injury or damage.
- Some parts may become hot during normal operation — handle with care.
- This product is covered by a limited warranty. Please read the enclosed warranty details for more information. Damage caused by crashes, negligence, or improper handling is not covered under warranty.

Section	Contents	Page
	Overview	4
	Main Car Components	5
1	Getting Started	6
1-1	Charging the Drive Battery	6
1-2	Setting Up the Transmitter	7
1-3	Preparing the Chassis	8
2	Setup	10
2-1	ESC/Receiver Overview	10
2-2	Binding/Pairing	11
2-3	Decals	11
2-4	Optional Lights	12
3	Switching On	13
4	Using the Transmitter	14
4-1	Transmitter Information	14
4-2	Steering	15
4-3	Throttle	15
4-4	Transmitter Indication Light	16
4-5	Practice Turning	16
5	Fail Safe System	17
5-1	Checking Fail Safe	17
5-2	Fail Safe Setup	18
6	Checking Radio Range	19
7	Basic Troubleshooting	20
7-1	Binding the Transmitter and Receiver	20
7-2	Steering Adjustments	20
7-3	Throttle Adjustments	21
8	After Use	22
8-1	Maintenance after driving	22
	Further Information	23
	Driving in wet conditions	23
	Troubleshooting	23

Additional Information

QS

Quick Start Guide



+



SG

This Guide



RMI

Transmitter Manual



TG

Technical Guide



+



i **EMI 1-1**

NOTE - This refers to the relevant guide (as above) and the relevant section. In this example, Section 1-1 of the ESC Manual.

Kit Contents



Radio Control Car



Transmitter



USB Battery Charger



2S Li-Ion (7.4V) Battery pack



LED Set

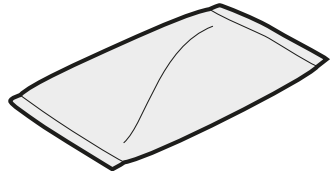

Spare parts bag

Equipment Needed

4x

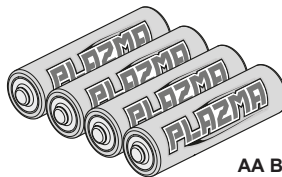

AA Batteries for Transmitter

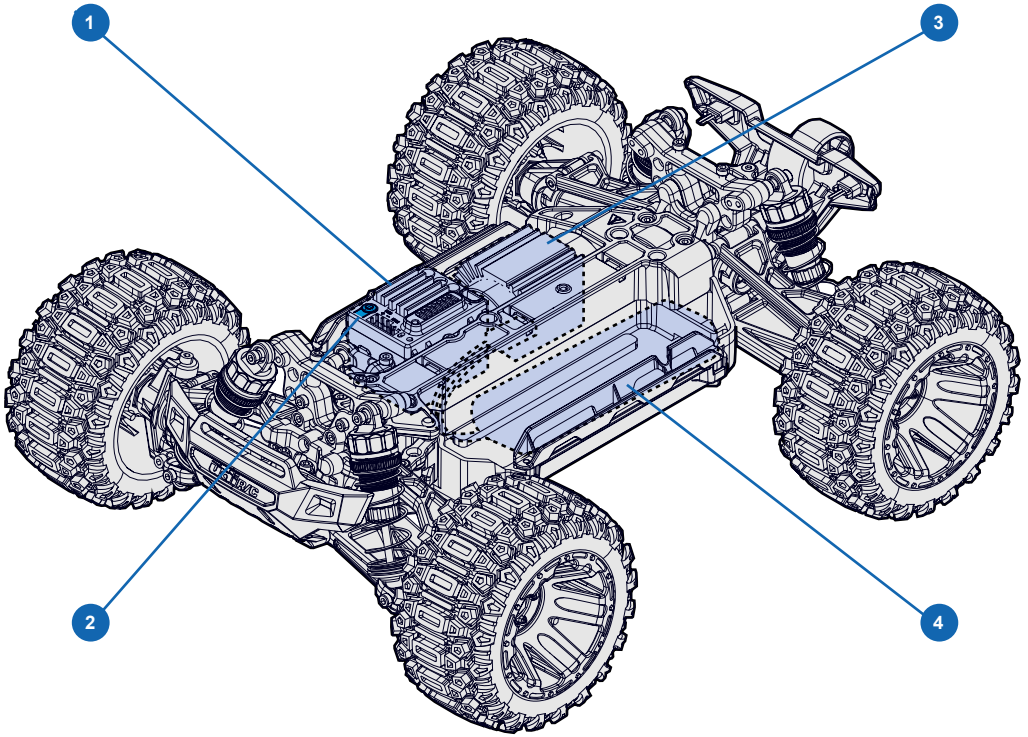

1 Electronic Speed Control (ESC)

3 Motor

2 Power Switch

2 Battery

1-1 Charging the Drive Battery



Caution

- Only use the supplied charger to charge the battery pack.
- Do not leave the battery unattended while charging.
- Do not use damaged or leaking batteries or chargers.
- Children must not charge the battery without adult supervision.
- Always disconnect the battery from the ESC/Receiver and remove it from the model when not in use.
- Fully charge the battery before each run.
- Do not leave the battery uncharged for long periods.
- Do not fully discharge the battery during use.
- Charge only in dry conditions. Do not charge in wet or humid environments.

1. Connect the charger plug to the battery pack connector
The connectors are shaped and include a clip to ensure correct connection.

Do not force them together – always check the alignment first.

2. The charger will automatically begin charging.

Charging will stop automatically once the battery is fully charged.

Error: Voltage out of charging range.

If this happens repeatedly, the battery pack may be damaged and should be replaced.

LED Status



Solid Green: Fully Charged



Flashing Green: Charging

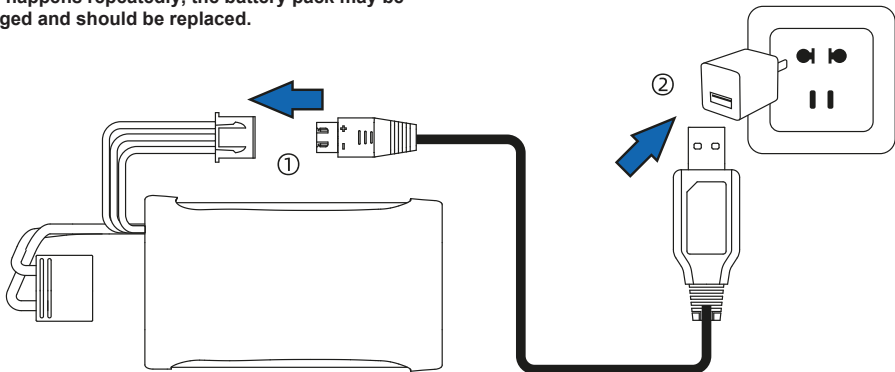

Caution

The USB charger requires a USB power adapter with an output of at least 2A.



Caution

Do not use NiCd or NiMH battery chargers for Li-ion/LiPo batteries.

Always use a charger specifically designed for Li-ion/LiPo batteries to prevent damage.

1-2 Setting Up the Transmitter

1-2-1 Transmitter Battery Installation

- 1** Open the battery cover on the bottom of the transmitter.

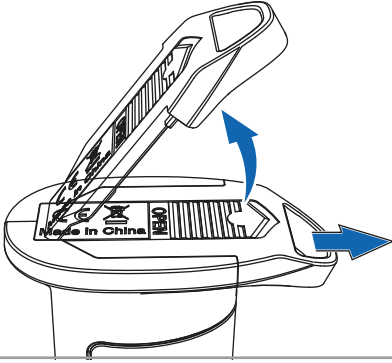

- 2** Lift and open the battery tray to reveal the empty battery slots.

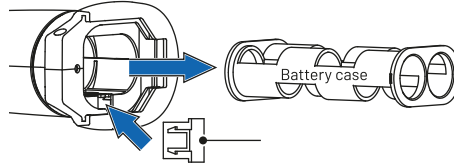

- 3** Insert four 1.5V AA batteries (not included) into the battery tray. Make sure to check the polarity (+ and -) markings carefully before closing the cover

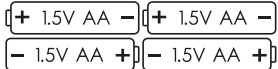

1.5V AA Battery *4pcs (Not included)

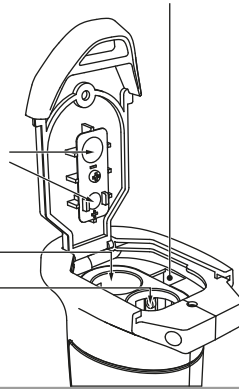

Tip

Always use high-quality alkaline or rechargeable NiMH AA batteries for best performance.

If using rechargeable batteries, remove them from the transmitter before charging.

1-3 Preparing the Chassis

1-3-1 Access Car Battery

1 Release the rear lock by pushing in the rear lock to release and remove the bodyshell.

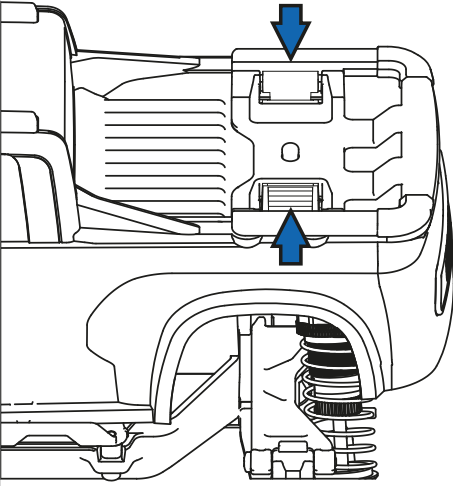

2 Gently lift the rear of the bodyshell upwards.

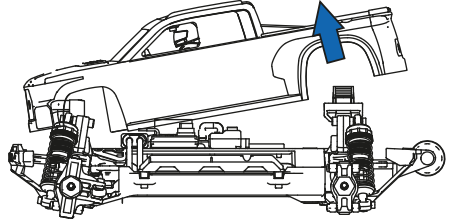

3 Unhook the front section by pushing the bodyshell forward to disengage the front hook from the front lock.

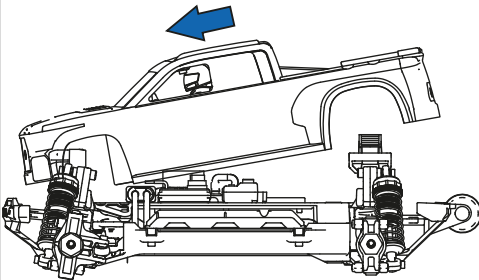

4 Remove the bodyshell by lifting the bodyshell upwards and away from the chassis to fully remove it.

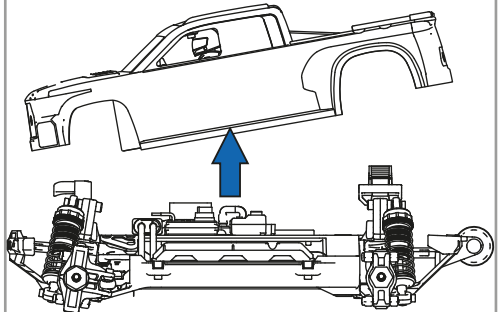

Tip

Always lift the bodyshell carefully to avoid bending or damaging the mounting hooks and clips.

1-3-2 Battery installation

1. Place the battery into the battery compartment.
2. Fasten the battery using the Velcro strap to keep it firmly in position.
3. Connect the battery by plugging the battery connector into the ESC/Receiver input.

Make sure the connectors are aligned correctly — do not force them together.

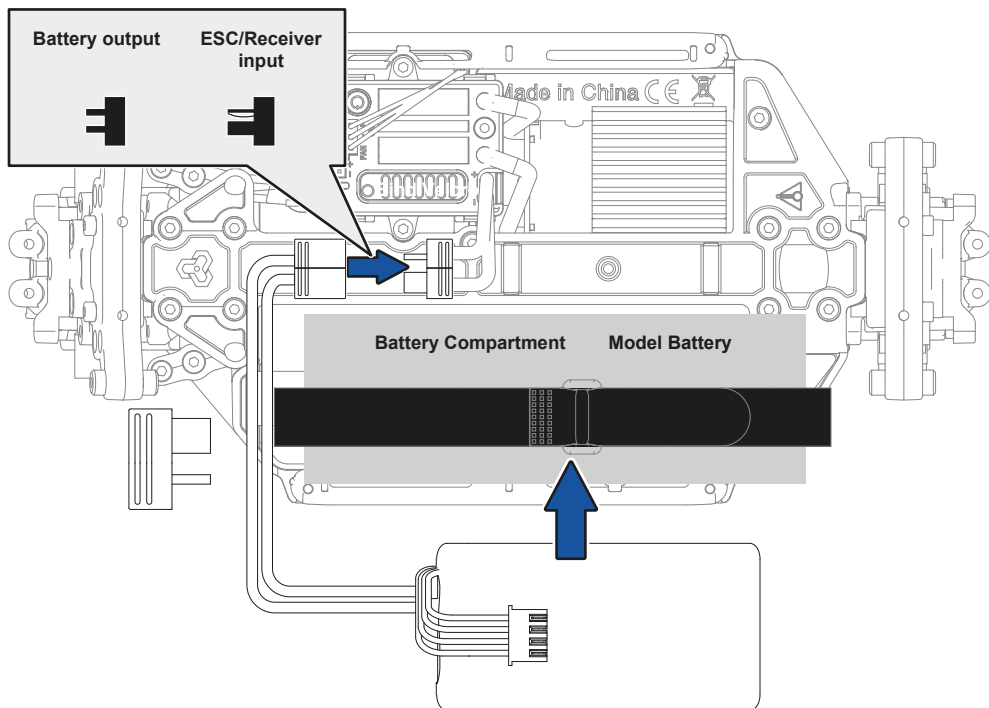

Caution

Always remove the battery from the model when not in use. Leaving it connected or installed for long periods may cause battery damage or swelling.

2-1 ESC/Receiver Overview

This unit combines the Electronic Speed Controller (ESC) and Receiver into a single compact module.

It manages motor power, steering control, and accessory outputs such as lights and fans.

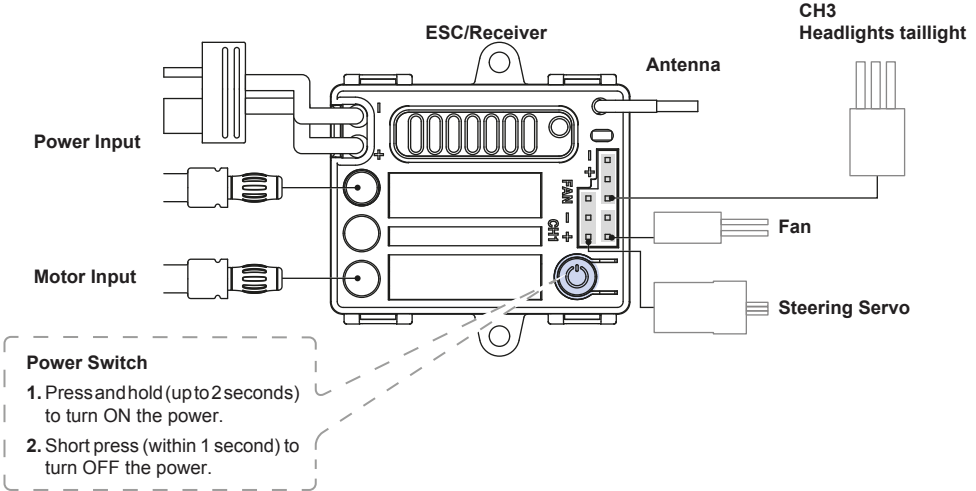

Connections

Power Input – Connects to the main drive battery.

Motor Output – Connects to the motor leads.

Steering Servo – Controls steering movement.

Fan – Supplies cooling power to the motor or ESC (if equipped).

CH3 Port – For optional headlights, taillights, or accessories.

Antenna – Provides signal reception from the transmitter.



Tip

Always double-check connections before switching on to avoid short circuits or reversed polarity.

2-2 Binding/Pairing

Binding (also called pairing) is the process of creating a secure connection between the transmitter and the ESC/Receiver, allowing the model to respond only to that specific transmitter. In most cases, the binding process will happen automatically when both the transmitter and the ESC/Receiver are switched ON and within range.

If auto-pairing fails, follow these steps to rebind the system manually:

1. Turn OFF all power sources.
2. Restart the ESC/Receiver power supply.
3. Press and hold the CH3 button while turning on the transmitter power, then release CH3.

When all indicator lights remain solid, it means the frequency pairing is successful.

If the lights continue to flash or the model does not respond, repeat the steps above until the connection is established.

2-3 Decals

A decal sheet is included with your model.

You can follow the suggested placement shown in the guide — or feel free to customise your model to create your own unique look!



2-4 Optional Lights

- 1** Remove the screws to separate the bumper assembly from the buffer plate.

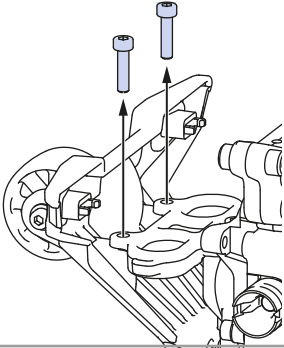

- 2** Insert the LED light beads diagonally into the light holes, then straighten them so they sit securely in place. This method makes installation easier and prevents damage to the LED or housing.

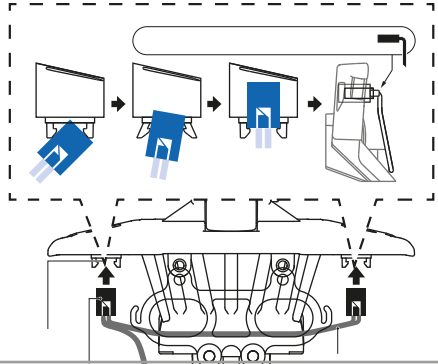

- 3** Refit the screws and use cable ties (or similar) to fasten the light wires neatly to the shock tower. Make sure the wires are routed away from moving parts

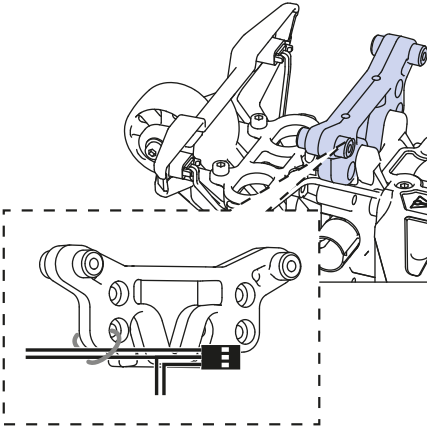

- 4** Connect to the ESC/Receiver - Insert the light wire plug into the correct socket on the ESC/Receiver, ensuring the metal contacts face outwards

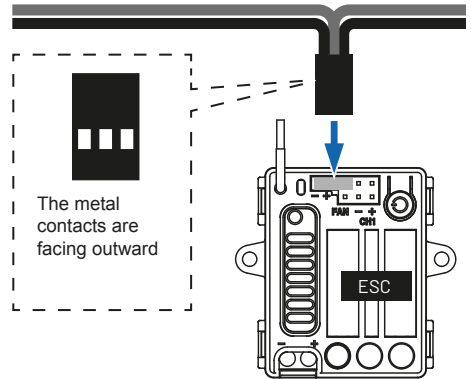

Attention

1. Check the wire lengths so they can reach the ESC/Receiver connection without strain.
2. Ensure the LED light beads are fully inserted into the light holes to prevent them from falling out.
3. Keep the wires clear of the shocks to avoid interfering with suspension movement.
4. Route the light wires beneath the bumper to prevent them from being pinched or damaged by the body.
5. Hide the light wires inside the body shell wherever possible to protect them from obstacles or debris while driving.

1 Switch on the transmitter first

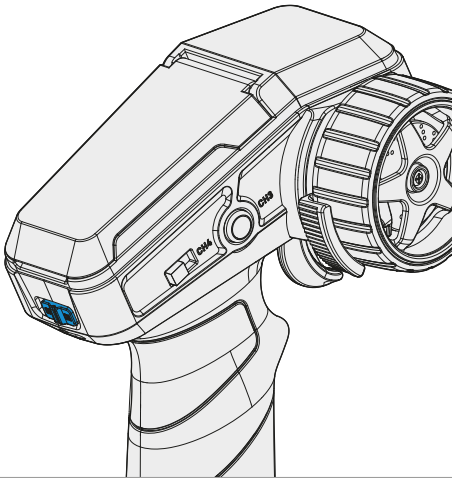

2 Then switch on the power on the ESC

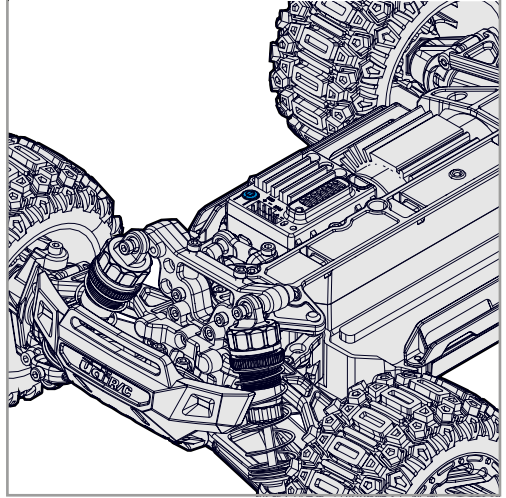

1. Always switch on the transmitter first, then power on the ESC/Receiver.

2. The transmitter and ESC/Receiver will automatically bind when both are powered on and within range.
If the indicator lights remain solid, pairing is successful.

If the lights continue to flash, the pairing has failed and will need to be repeated.

To bind manually, turn on the transmitter first, then press and hold the bind button on the receiver for about 3 seconds until the indicator light flashes.

The receiver will search for the transmitter signal automatically.

Once pairing is complete, the receiver light will stay solid.

Before starting, ensure the throttle trigger and steering wheel are in the neutral position.

Do not touch the throttle trigger while powering on.

After switching on, the system will automatically connect.

If the receiver light flashes during use, check the signal and rebind the system if necessary.



Tip

If you change the transmitter or receiver, rebinding is required.
Refer to Section 4-6 for full binding/pairing instructions.

4-1 Transmitter Information

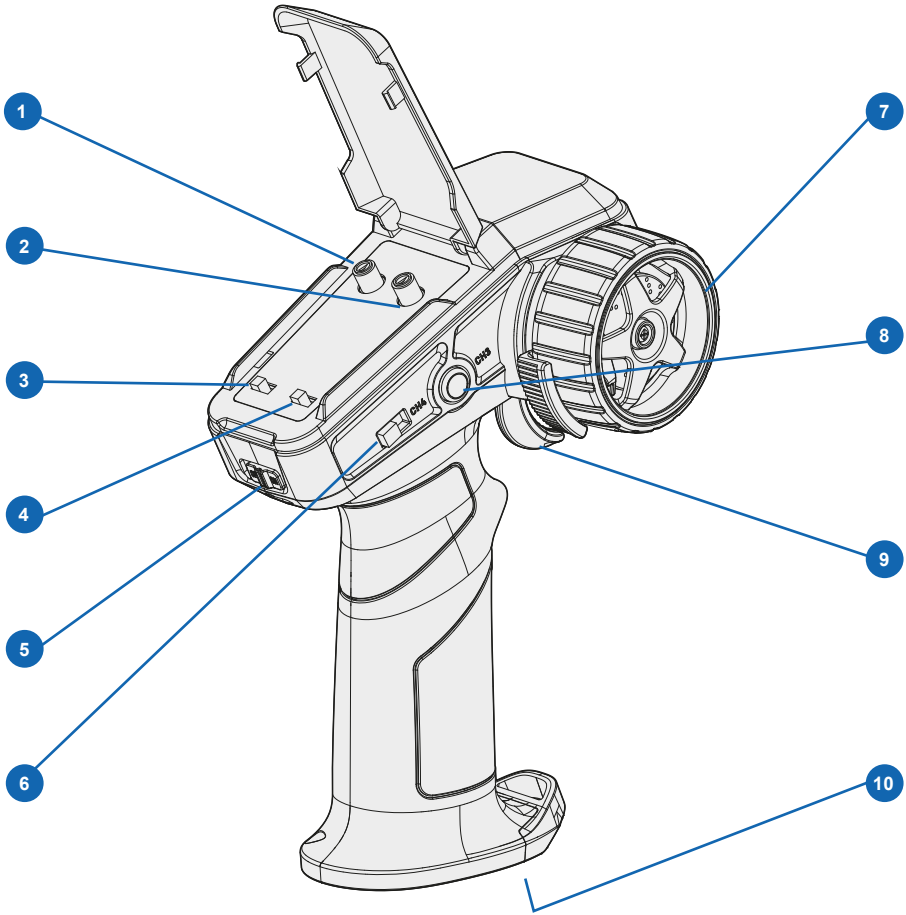

- 1 Steering Trim
- 2 Steering Dual Rate
- 3 Throttle Reverse
- 4 Steering Reverse
- 5 Power on/ off
- 6 Throttle Trim/CH4

- 7 Steering Wheel (CH1)
- 8 CH3
- 9 Throttle Trigger (CH 2)
- 10 Battery Cover

4-2 Steering

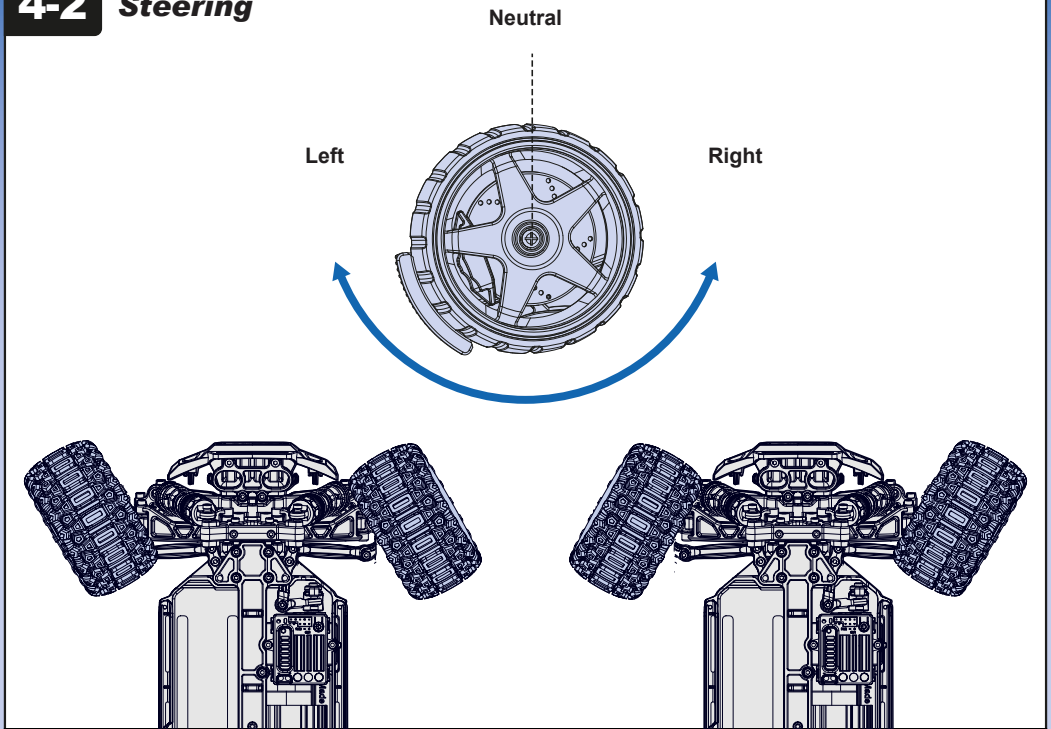

4-3 Throttle

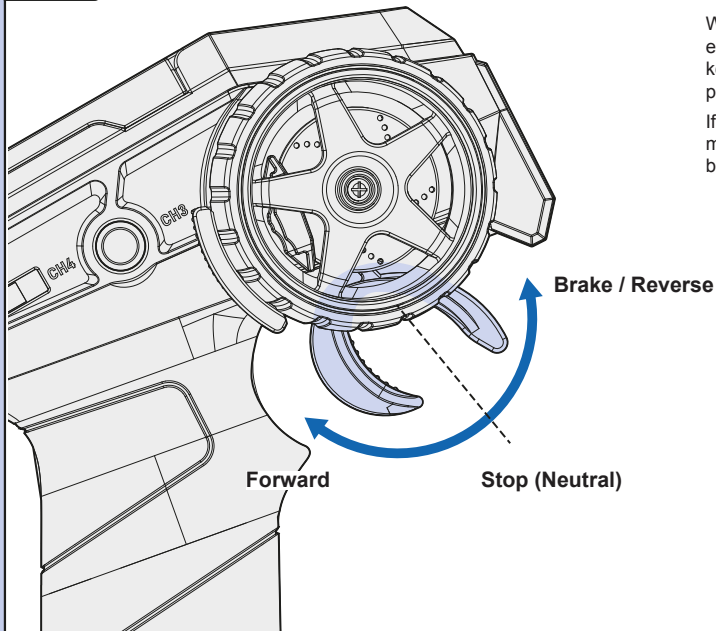

Note:

When using the transmitter with electric-powered models, always keep the throttle trigger in the neutral position when switching on.

If the trigger is not centred, the model may not initialise correctly or could behave unpredictably during operation.

4-4 Transmitter Indication Light

Situation 1:

If the signal becomes weak or is lost, the indicator light will flash quickly.

Situation 2:

If the transmitter battery power is low, the indicator light will flash slowly.

If either of these situations occurs, stop using the model and check the batteries or signal connection immediately to prevent loss of control or accidents.

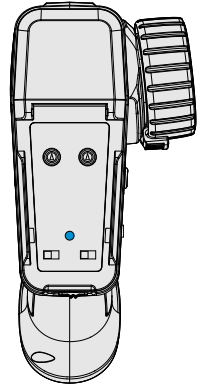

4-5 Practice Turning

Install the body and have fun!

Allow the model to cool down for at least 15 minutes between runs.

When the car is driving toward you, remember that the steering directions will feel reversed — turning the wheel left makes the car turn right, and vice versa.

Once you are comfortable controlling your RC model, try setting up a simple track or practice area using cones or markers to improve your driving skills.

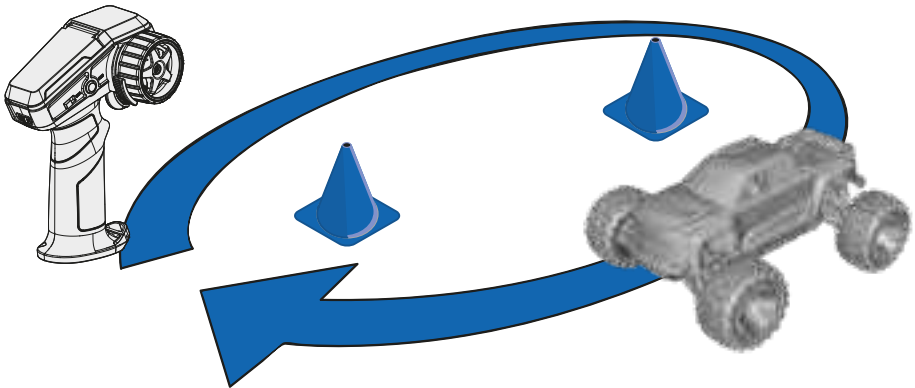
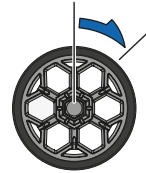

Caution

Do not run your model in water, mud, or sand.

Never drive on public roads or highways — this can cause accidents, injury, or damage to property.

This car is equipped with a built-in fail safe system.

If the radio signal becomes weak, is interrupted by interference, or goes out of range, the system will automatically apply the brakes to help stop the car and prevent damage.

The fail safe is pre-set at the factory, but you should become familiar with its function and check the operation before each run.



Caution

Any new binding of the transmitter and receiver will clear the preset fail safe. See Section 5-2 for setup.



Caution

The fail safe cannot completely protect your car. Always drive with care and remain in control of your vehicle.

5-1 Checking Fail Safe

With both the transmitter and car switched ON, press and release the setup button on the receiver. The LED will start flashing.

Electric Setup

1. Leave the throttle trigger in the neutral position.
2. Press and hold the setup button again — the LED will flash quickly.
3. When the receiver LED stays solid, release the setup button.

The fail safe is now set.

Nitro Setup

4. Hold full brake on the transmitter, then press and hold the setup button on the receiver.
5. The LED will flash quickly.
6. Keep holding full brake until the receiver LED remains solid, then release the setup button.



Tip

Test the fail safe before running by switching off the transmitter. The car should brake or stop immediately. If not, repeat the setup process.

5-2 Checking Fail Safe

- 1** Place the car on a stand and ensure it is powered off.

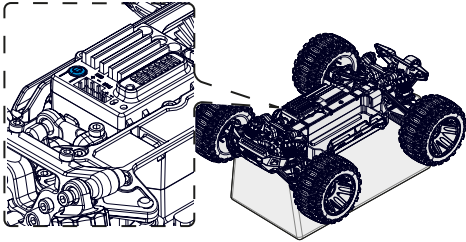

! Make sure the wheels can move freely and the model is safely supported before setup.

- 2** Connect the battery.

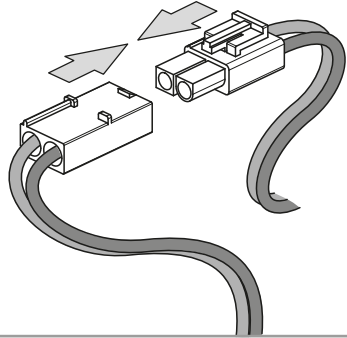

- 3** Turn on the transmitter first, then the car.

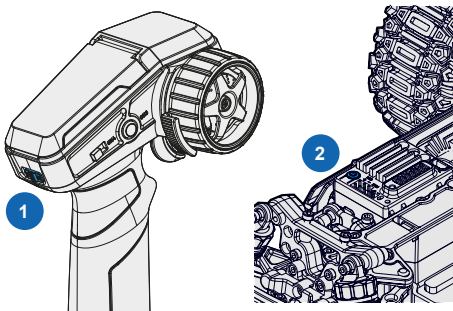

! Ensure both the transmitter and the ESC/Receiver are powered on for setup.

- 4** Set the throttle and steering to neutral.

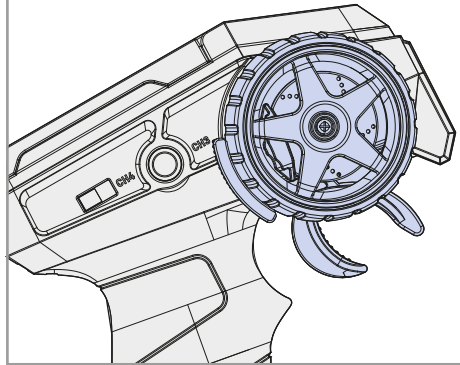

- 5** Pull the throttle trigger fully clockwise, turn the steering wheel fully counterclockwise, then switch on the transmitter power.

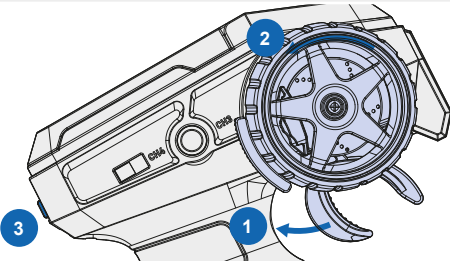

! The indicator light will flash rapidly to show it is in setup mode. Release the throttle trigger and steering wheel.

- 6** Calibrate the throttle - Pull the throttle trigger fully clockwise, then fully counterclockwise, and finally return it to the neutral position. Release the trigger.

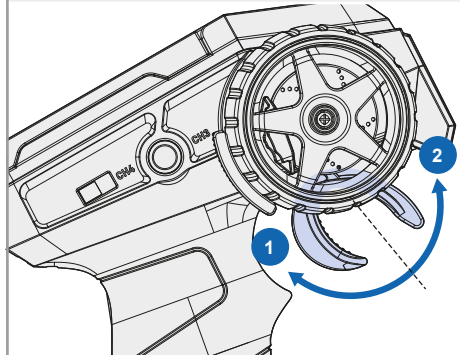

7 Calibrate the steering.

Turn the steering wheel fully clockwise, then fully counterclockwise, and finally return it to the center position.

Release the steering wheel.

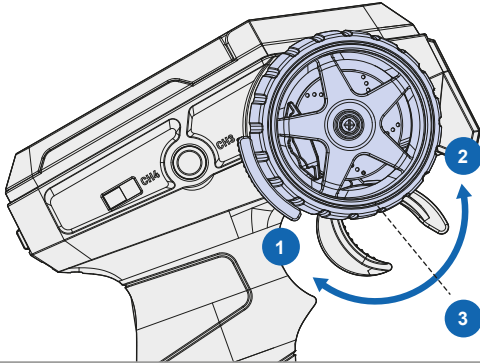

8 Confirm the setting.

Press the CH3 button to confirm, then switch off the transmitter.

The fail safe setup is complete.

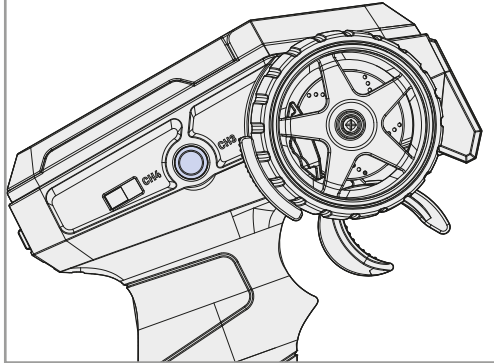

Tip

To check the fail safe function, turn off the transmitter — the car should brake or stop immediately.

If it does not, repeat the setup steps.

6 CHECKING RADIO RANGE

To check the radio range safely:

Ask a friend to hold the model securely while you walk to the farthest distance you plan to operate it. Use the transmitter controls to confirm that the model responds correctly.

If you notice any delay, loss of signal, or unusual behaviour, do not operate the model until the issue is resolved.

Always switch on the transmitter first, then the model.

If the model is powered on before the transmitter, you may lose control.

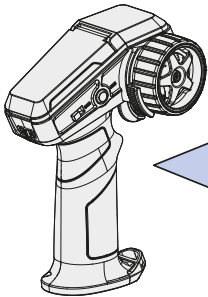

Cautions

The 2.4GHz radio system works best within a clear line of sight.

If the model goes behind solid objects or around corners, you may lose signal and control.

7-1 Binding the Transmitter and Receiver

This process normally happens automatically when the transmitter and receiver are powered on.

You may need to manually bind your transmitter to the receiver if:

1. You replace the receiver or transmitter.
2. The system loses signal or fails to connect automatically.

7-1-1 Binding Procedure

3. Place the transmitter and receiver close together (within 1 metre).
4. Turn ON the transmitter by pressing and holding the power switch.
5. On the receiver, press and hold the setup button, then switch the receiver power ON.
6. The receiver LED will flash quickly — release the setup button after about one second.
7. On the transmitter, press and hold the bind button for one second, until the receiver LED stays solid.
8. This confirms the binding is successful.



Tip

Keep the transmitter and receiver close during binding for best results.
If the LED continues to flash, power both units off and repeat the process.

7-2 Steering Adjustments

7-2-1 Steering Trim Setup

Steering Trim:

The steering trim control allows you to make fine adjustments to the steering centre point from your transmitter.

If your RC car does not drive in a straight line when the steering wheel is centred, turn the ST TRIM dial slowly until the car tracks straight.

This adjustment helps keep your RC car driving straight without constantly correcting the steering.

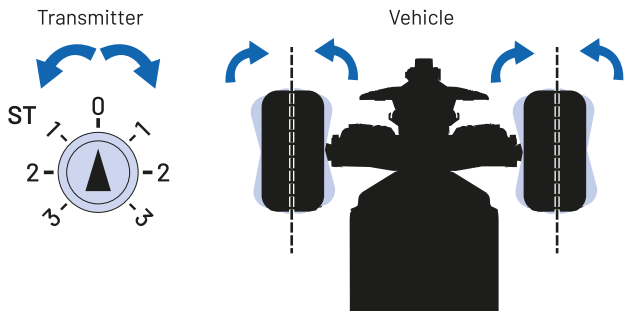

7-2-2 Steering Dual Rate Setup

Steering Dual Rate:

The Steering Dual Rate (ST D/R) knob adjusts how far the front wheels turn when you steer.

1. Turn the knob clockwise to increase steering throw (tighter turning).
2. Turn the knob anticlockwise to reduce steering throw (smoother control).

For best handling, it's recommended to keep the steering throw within 75%.

This helps avoid excessive turning that can cause the front tyres to rub against the body shell and ensures smoother, more precise steering control.

Transmitter

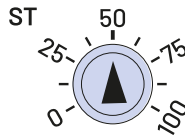
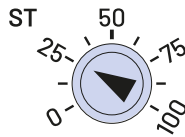
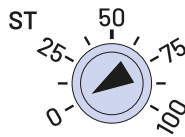

Vehicle

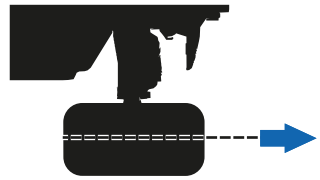

Tip

Adjust the steering dual rate while driving to fine-tune handling — increase it for tight corners or decrease it for better stability at high speeds.

7-3 Throttle Adjustments

7-3-1 Throttle Rate Setup

The Throttle Speed Limiter allows you to set the maximum throttle output of your RC model.

There are three speed levels available: 50%, 75%, and 100%.

1. **L (Low Speed – 50%):** Recommended for beginners or training mode.
2. **N (Medium Speed – 75%):** Suitable for general driving and mixed conditions.
3. **H (High Speed – 100%):** Full power mode for experienced users.

Start at a lower speed setting until you become comfortable with the handling of your model, then increase as your driving skills improve.



8-1 Switching Off

1. Switch off the model.

Short press (≤ 1 second) the ESC/Receiver power button to turn off the model, then disconnect and remove the battery.

2. Remove the bodyshell.

Refer to Section 1-3 for instructions on removing the body.

3. Turn off the transmitter.

Switch off the transmitter power and remove the batteries if the model will not be used for an extended period.



Attention

Always power OFF the ESC/Receiver before the transmitter to prevent loss of control.



Caution

Disconnect the battery whenever the model is not in use.
If left connected, the vehicle may start unexpectedly or the battery may overheat and cause a fire.

8-2 Maintenance after driving

Regular maintenance is very important to keep your RC model in top condition.

After each run, clean the chassis and check all moving parts for any damage or wear.

If any parts are broken or worn out, repair or replace them before your next run.

Routine maintenance helps prevent damage and keeps your model performing reliably.

Completely remove any dirt or debris from the model, paying special attention to the suspension, drive shafts, and steering components.

Check that all screws and fasteners are tight and that no parts are missing or loose.

Use the schedule below as a general maintenance guide.

Interval	Maintenance Item
After every run	Clean chassis and suspension, remove dirt and debris.
Every 10 runs	Check wheels, tyres, and bearings. Inspect gears and drivetrain for wear.
Every 20 runs	Inspect and clean motor and pinion gears. Check differential and shock absorbers. Lubricate moving parts.
Occasionally	Check radio system, wiring, and connectors. Replace batteries if needed.



Tip

Perform maintenance more frequently if driving in dusty, wet, or sandy conditions.

Driving in wet conditions

This model is designed with water protection for the on-board radio components, allowing it to be used in light wet conditions, such as on damp surfaces or through shallow puddles.

However, the vehicle is not waterproof and should never be fully submerged in water.

Driving in wet conditions will require additional cleaning and maintenance after each run.

Notes:

1. Do not drive in heavy rain or stormy weather, and avoid using the model where lightning may be present.
2. The transmitter is not waterproof — always keep it dry and protected from rain.
3. After driving, remove all water and mud, and dry the model completely.
4. Check for trapped water in tyres, suspension, or transmission areas.
5. Some metal parts such as bearings and hinge pins may require lubrication after use in wet or damp conditions
6. The motor is not designed to be submerged. Water entering the motor may shorten its lifespan.
7. Most battery packs are not suitable for wet conditions.
8. After running in wet areas, dry the ESC and connectors thoroughly before storing or recharging.



Tip

After driving in wet or damp conditions, perform a quick inspection and reapply bearing oil or grease to maintain long-term performance.

Troubleshooting

If R/C car does not move or you have no control, see below.

If you encounter any other fault whilst operating the vehicle please contact your local hobby shop.

Problem	Cause	Remedy
Does Not Move	Battery is not placed properly in the transmitter.	Place batteries in the transmitter properly.
	Weak or no batteries in transmitter or model.	Install charged or fresh batteries.
	Damaged motor.	Replace with new motor.
	ESC is shut down by heat protection circuit.	Stop driving immediately, do not drive the car until the Speed Controller cools down.
	Binding Setup is incorrect.	Make sure binding is setup properly.
The vehicle does not follow your driving inputs	Servo reverse switch is in the wrong position.	Check the reverse switch settings
	Wires from ESC to motor are improperly connected.	Connect wires from ESC to motor correctly
	Neutral position or trim is incorrect.	Adjust the steering trim.

FCC COMPLIANCE STATEMENT

This device transmits in the range 2.4 to 2.4835 GHz and has been tested to comply with the limits for a Part 15 Class B device of the FCC rules. These limits are designed to provide reasonable protection against harmful interference in a residential installation. This equipment generates, uses and can radiate radio frequency energy and, if not installed and used in accordance with the instructions, may cause harmful interference to radio communications. Any change or modification to the device not expressly approved by the manufacturer may void the user's authority to operate the equipment. Operation is subject to the following two conditions:

(1) This device may not cause harmful interference, and (2) This device must accept any interference received, including interference that may cause undesired operation.

Canada Compliance Statement:

This Class B digital apparatus complies with Canadian ICES-003. (Cet appareil numérique de la classe B est conforme à la norme NMB-003 du Canada.) This equipment complies with the FCC/IC radiation exposure limits set forth for FCC and Industry Canada portable transmitting devices operation in an uncontrolled environment. The equipment should only be used or installed at locations where there is normally at least a 20cm separation between the antenna and all persons. This transmitter must not be co-located or operated in conjunction with any other antenna or transmitter.

CE Compliance statement

The radio equipment type in this product transmits in the frequency range 2.4 to 2.4835 GHz with a maximum power of 18dBm and is in compliance with EU Directive 2014/53/EU. The full text of the Declaration of Conformity is available at www.hpiracing.com/ce

Cet appareil transmet dans la gamme de fréquence de 2,4 à 2.4835 GHz avec une puissance de 18dBm et est conforme à la Directive UE 2014/53 / UE.

Le texte intégral de la Déclaration de conformité est disponible sur www.hpiracing.com/ce

El tipo de equipo de radio en este producto transmite en el rango de frecuencia de 2.4 a 2.4835 GHz con una potencia máxima de 18dBm y cumple con la Directiva de la UE 2014/53/UE. El texto completo de la Declaración de conformidad está disponible en www.hpiracing.com/ce

MVK

HPI RACING A/S

Jegindoevej 21

8800 Viborg, Denmark

Email: info@hpiracing.com

WWW.MAVERICK-RC.COM