

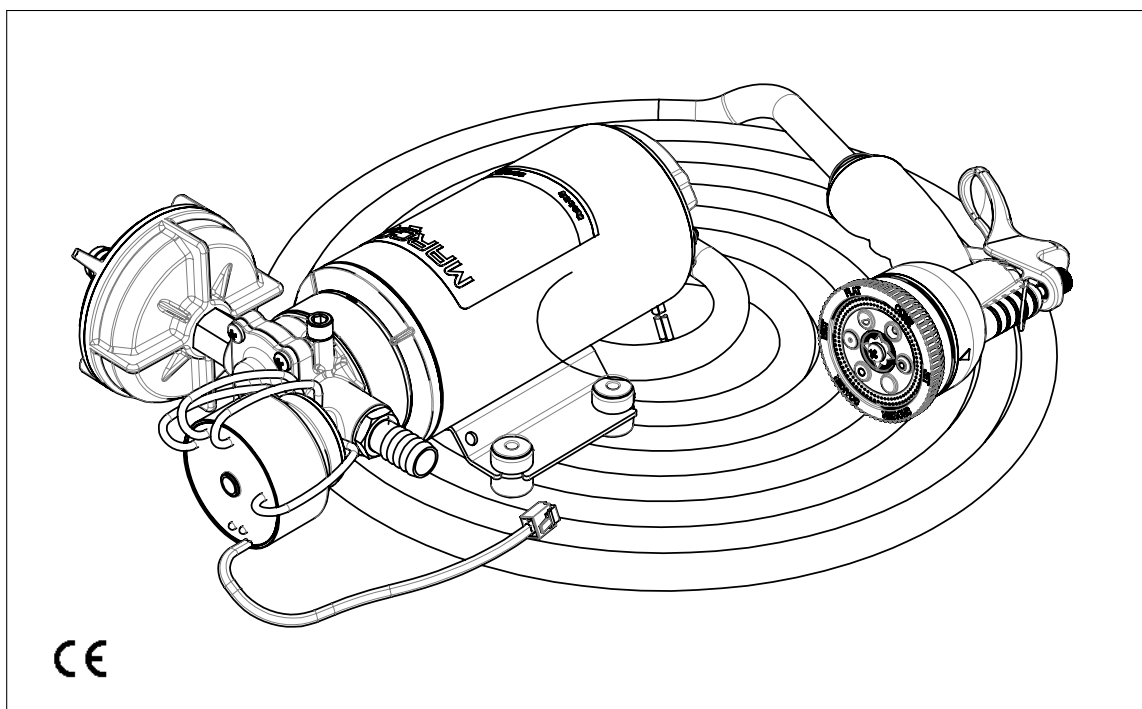

SELF-PRIMING ELECTRIC PUMP FOR TRANSFERRING VARIOUS LIQUIDS

INSTRUCTIONS FOR USE

1E483115 - DP10/E-MS 12/24V



AIR VENT VALVE ACTIVATION

When starting the pump, or when emptying the tank, slightly open the small valve, in order to let air out and facilitate the priming. As soon as the pump is operating, close the small valve. On the outlet side it is advisable to use at least a short section of 1 m length flexible tubing.

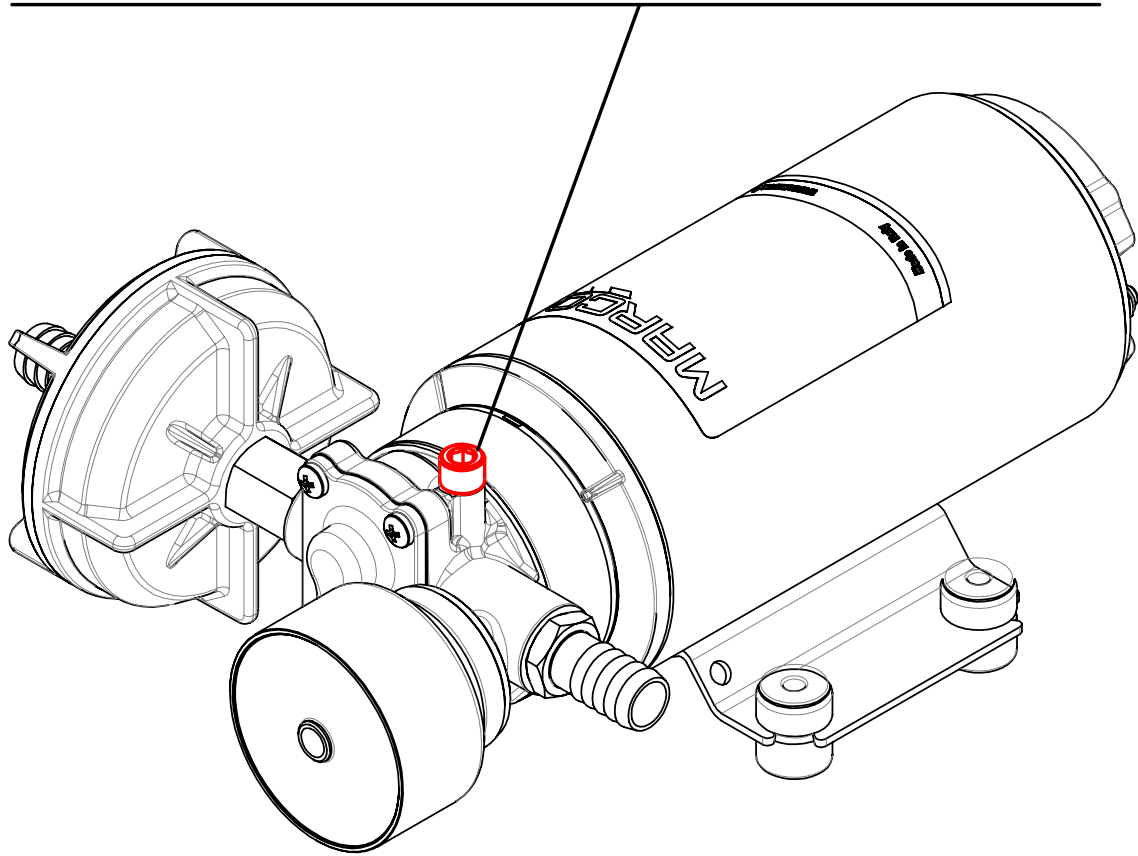

ELECTRONIC PRESSURE SENSOR WORKING DIRECTIONS

The electronic pressure sensor, through the use of a microprocessor, controls the pump's speed to obtain the needed flow rate, with the following advantages:

- ⇒ Noise reduction during operation.
- ⇒ The optimization of current consumption.
- ⇒ A strong reduction of electrical noise, thanks to the slow speed ramp up and ramp down of the motor.
- ⇒ A longer life for the whole system, thanks to less wear of pump parts compared to conventional mechanical pressure switches.

The pressure sensor system is equipped with two LEDs: one blue and one multicolored (red, green, and yellow).

During normal operation, the blue LED will:

- ⇒ Turn on if there's liquid in the hoses.
- ⇒ Turn off when there's no liquid in the hoses.
- ⇒ Flash when in priming mode. The first time it senses water it keeps flashing for 10 seconds to make sure that the water is being pumped correctly and continuously. If the pump goes more than five times from "priming" to "no liquid" (blue led off) the circuit turns everything off anyway, to protect the motor and the gears from running without liquid.

The multicolored LED signals:

- ⇒ With solid yellow LED, that the pressure in the hoses is not the required pressure, but the pump is trying to reach it.
- ⇒ With solid green LED, that the pump has reached the target pressure, there is still liquid demand, but the pump's speed won't be changed because the flow rate is constant.
- ⇒ With flashing green LED, the pump has reached the target pressure and there is no liquid demand, it's in stand-by with the motor off.
- ⇒ With solid or slowly flashing red LED, the motor has been short circuited, something may have blocked the gears or there could be a problem in the connection between the pump and circuit. The red LED flashes for 30 seconds, after which the pump is re-fed up to a maximum of 3 attempts. On the fourth attempt, the LED remains solid red, the pump is off and should be checked for possible permanent damage. To reset this warning you need to reboot the circuit or press the Reset button on the control panel, if present.
- ⇒ With fast flashing red LED, the pump is being overloaded (due to viscous liquids or gears overheating). While the pump is running, the speed is reduced to keep the current up to the nominal value for 30 seconds, period after which the circuit tries to release again the motor to its normal operating speed. If an overload happens again, the circuit tries three times to lower the speed and it turns the pump off. Please check that the liquid being pumped is correct for the chosen pump and that the gears move freely without problems. To reset this warning you have to reboot the circuit or press the Reset button on the control panel, if present.

There are two warnings that use both LEDs:

- ⇒ Red and blue LED that blink alternatively, signal that the pump has run without liquid for the time listed in table N.1 and the motor has been stopped for this reason. To reset this warning you have to reboot the circuit or press the Reset button on the control panel, if present.
- ⇒ Yellow and blue LED that blink together indicate that the power supply is providing the wrong voltage. Please check to have the correct wire section for the power supply and a charged battery, if present.
- ⇒ Steady red and blinking Blue indicate that the pump has run for more than the time listed in table N.1 at very low speeds and that the motor has been stopped to prevent overheating. To reset this warning you have to reboot the circuit or press the Reset button on the control panel, if present.

WARNINGS

An expansion tank of at least ½liter is necessary in the case of short, rigid pipes or in the presence of solenoid valves, to avoid overpressures during the closing phase caused by a water hammer effect which could damage the pressure sensor.

The presence of a few meters of flexible pipe inside the system can prevent the installation of the expansion tank.

Additional pressure regulators or non-return valves on the pump delivery may interfere with the correct operation of the electronic pressure sensor.

TIMEOUTS	DURATION
NO LIQUID TIMEOUT	1 minute and 30 seconds
SLOW SPEED TIMEOUT	2 hours

LED COLORS	SOLID	BLINKING SLOW (500 ms)	BLINKING FAST (150 ms)	OTHER
GREEN	Target pressure precisely reached	Ready to start		
YELLOW	Target pressure not reached		Automatic recalibration performed	
RED	Shortcircuit or hard overcurrent detected multiple times	Shortcircuit or hard overcurrent detected once	Unexpectedly high currents detected	
BLUE	Liquid is present		Priming mode	
RED+BLUE ALTERNATING		Liquid has not been detected, pump stopped for protection		
RED SOLID+BLUE BLINKING				Slow speed timeout reached or the connection with the control panel has been lost, after being detected
YELLOW+BLUE		Problems with the power supply		

DESCRIPTION

Complete kits with self-priming electric pump and electronic control, in high-pressure version with mechanical seal. Equipped with helical gears in PEEK, inline filter, nickel-plated brass body, and check valve. Includes 15 m of extendable hose, spray gun with quick-connect fitting, jet lock, check valve, and flow-regulating trigger. The kits are particularly suitable for washing operations with both saltwater and freshwater.

TECHNICAL DETAILS

PRODUCT DATA

CODE	TYPE	DESCRIPTION	WEIGHT	
1E483115	DP10/E-MS	DP10/E-MS 12/24V Washing Pump Mechanical Seal, Electronic Control 10 bar	kg	5,5
			lb	12.1

MOTOR DATA

VOLTAGE [V]	CONSUMPTION [A]	FUSE [A]	MOTOR POWER [W]	IP PROTECTION	WIRE	
12/24	26	30	320	67	mm ²	4
					AWG	12

PUMP DATA

SELF-PRIMING [m]	FLOW RATE [l/min]	PRESSURE [bar]	HOSE [mm]	PORTS [BSPP]
3	18	8	13	3/4"

PUMP DATA (USA)

SELF-PRIMING [ft]	FLOW RATE [gpm]	PRESSURE [psi]	HOSE [in]	PORTS [BSPP]
9.8	4.8	116	0.5	3/4"

FLUIDS ALLOWED / NOT ALLOWED

<u>LIQUIDS</u>		<u>DANGERS</u> ⚠				
WARRANTY EXPIRES IF MAX FLUID TEMPERATURE IS EXCEEDED		FIRE / EXPLOSION	MOTOR OVERHEATING	PUMP CORROSION	INJURY TO PERSONNEL	DAMAGE TO SEALS
		OK	WATER (max 85 °C)			
NO 	PETROL (GASOLINE)	●			●	
	SOLVENTS	●			●	●
	FLAMMABLE LIQUIDS with PM < 38 °C	●				
	LIQUIDS WITH VISCOSITY > 20 cSt		●			
	CORROSIVE CHEMICAL PRODUCTS			●	●	●
ISO 8846 Compliant Device						

AMBIENT CONDITIONS

TEMPERATURE: min. $-10^{\circ}C/14^{\circ}F$ / max. $+60^{\circ}C/140^{\circ}F$

⚠ WARNING: the above indicated temperature ranges are applicable to all components of the pump and these limits must be respected in order to avoid any possible damage or malfunctioning.

OPERATING CYCLE

Under conditions of high operating pressures the pump can be subjected to elevated stresses and overheating and therefore should not be used for prolonged periods under such conditions.

TRANSPORTATION AND HANDLING

Due to limited weight and dimensions the pump does not require the use of any special handling or lifting equipment. When handling manually, normal personal protective gear should be worn (safety shoes with toe piece, etc.). The pump is carefully packed prior to shipment. Upon receiving, the packaging should be inspected for damages and the pump stored in a dry area.

INSTALLATION

It is recommended that the use of the pump be according to normative safety standards and also as per the precautions listed below.

PRELIMINARY CHECKS

Check that there has been no damage to the pump during transportation or storage. Both inlet and outlet ports should be carefully cleaned removing possible dust or residual packaging material. Verify that the available electrical power supply corresponds to the specification requirements.

POSITIONING

The pump can be mounted in any position. Fix the pump utilizing suitable diameter screws corresponding to the holes. To ensure the correct directional flow of the fluid as indicated by the arrow on the top plate, it is necessary to connect the positive pole (+) of the battery supply to the red wire on the motor end-cap and the negative pole (-) to the black wire. Electrical connections must be made using adequate terminal blocks and connectors ensuring a tight fitment of the electrical cables. Bad wiring can cause power losses and/or overheating of the cabling itself.

⚠ WARNING:

it is the responsibility of the installation technician to ensure a correctly designed circuit installation fitted according to regulations. Environmental risks must be taken into account with the installation.

TUBING CONNECTIONS

- ⇒ Prior to making any tube/hose connections, check that the inlet ports have no end caps.
- ⇒ Do not position the pump at a excessive height with respect to the minimum level of the fluid to be transferred. Damage may occur if this height is exceeded as the pump may not draw fluid. Make sure that the outlet tube is empty and without chokes.
- ⇒ Avoid choking the inlet or outlet tubes so that efficiency is optimized.
- ⇒ The use of an inlet filter is recommended especially with fluids containing impurities (mesh ASTM no. 35). In this case frequent cleaning and maintenance of the filter is advisable. The standard filter withstands a maximum positive pressure of 0.5 bar.
- ⇒ Utilize tubes and connection pieces that are resistant to the fluid types handled and avoid any possible environmental dispersion.

ELECTRICAL CONNECTION

The electrical installation of the pump must include a protection fuse which is suitably rated as indicated on the motor label.

WARRANTY EXPIRES IF NO FUSE IS UTILIZED

Always mount the anti vibration rubber fittings supplied with the pump kit. Their usage ensures a consistent reduction in noise and vibration levels. Electrical cabling size should depend on the distance between pump and battery/power supply (see **Motor Data Table**). The use of undersized cabling can cause overheating of the electrical wiring and subsequent fire hazard. There will also be a voltage drop at the motor terminals with a consequent reduction in efficiency. The flow rate value indicated on the motor label is obtained with internal tube diameter indicated on **Pump Data Table** . Tubes with inferior diameters will cause an increase in current with potential risk of motor overheating.

TROUBLESHOOTING

CHECK POINTS IF THE PUMP HAS STOPPED OR WILL NOT START

- ⇒ Check the effectiveness of the battery power supply (voltage activity).
- ⇒ Check if the fuse has blown.
- ⇒ Check for any foreign matter present in the pump body. To do this, disconnect the power supply and unscrew the four fixing screws, remove the front cover plate and inspect the chamber. Replace the cover plate in the same initial position after inspection.
- ⇒ Avoid running the pump dry for more than a few minutes. Pumps found defective that have run dry in the absence of fluid are not covered by warranty.
- ⇒ The average life span of the motor commutator brushes is approximately 2500 hours under normal operating conditions. Stoppages are possible due to brush wear and tear after such a time period.

WHY THE PUMP WILL NOT PRIME ITSELF?

- ⇒ The pump is fitted at an excessive height above the fluid level
- ⇒ The pump has run dry for too long a period
- ⇒ Long periods of inactivity. In this case it is advisable to add liquid directly into the chamber before start-up
- ⇒ Air leak at the suction pipe due to the following reasons, possible cuts in the pipe, inadequate hose clamps, malfunctioning of the filter due to defective/worn seals or filter clogged
- ⇒ Air leak at the front plate cover due to the following reasons, loose fixing screws, poor effectiveness of the seal
- ⇒ Faulty electrical cable connections
- ⇒ Presence of obstructions or restrictions in the suction or delivery pipes or the use of special devices (eg. automatic spray pistol or Aquastop)
- ⇒ Presence of liquid loops in the outlet tube

GOOD PRACTICES ENSURING A WELL FUNCTIONING PUMP

If it is expected that the pump will not be used for a period of at least 30 days, especially in the case of usage with water, it is advisable to run fresh water through it and to then loosen the front plate screws. Upon re-use, run the pump briefly (a few seconds) and tighten the screws again. Check under conditions of maximum operating pressure that the motor current value is within the motor label specifications.

NORMAL MAINTENANCE

- ⇒ Check frequently and keep the inlet filter clean.
- ⇒ Check every month the chamber and keep clean from any foreign matter.
- ⇒ Check every month that electrical wiring is in good condition.

INDICATORS THAT THE PUMP IS FUNCTIONING CORRECTLY

- ⇒ Temperature of body and motor frame is within $60^{\circ}C/140^{\circ}F$ and $70^{\circ}C/158^{\circ}F$
- ⇒ Regular flow and constant noise levels.
- ⇒ Amp-draw within the limits indicated in the diagrams.

TO OPEN THE PUMP

- ⇒ It is recommended that a specialized service technician be consulted for any repair work or the replacement of worn out internal components, exclusively with original spare parts; during the warranty period, only by authorized MARCO S.p.A. personnel, failing which the warranty will expire.

ENVIRONMENTAL DISPOSAL

It is the responsibility of the owner to dispose of this product by means of the specific refuse collection structures indicated by the government or the local governing authorities.

PACKAGING ENVIRONMENTAL DISPOSAL

The user is invited to effect a proper waste separation, in order to facilitate the recycling of the materials of which the packing is composed.

WARRANTY

1. The Warranty period is 2 years from date of purchase on production of the appropriate sales invoice.
2. Should the original sales invoice not be available, then the 2 year warranty period will be valid from production date.
3. The Warranty becomes null and void in the case of incorrect utilization or disregard of the instructions contained herein.
4. The Warranty only covers original production defects.
5. The Warranty does not cover any related installation costs involved.
6. Transport costs are refundable only in the case where warranty has been duly accepted by MARCO Spa and they will be limited to the actual shipment costs between MARCO Spa warehouse and the client's delivery address.
7. No credit notes or replacement items will be issued prior to the receipt and proper testing of any MARCO goods that are deemed faulty.

EXPLODED VIEW

Pos.	Q.tà	Descrizione	Description	Ricambio Spare Part
1	1	CORPO POMPA	PUMP BODY	
2	1	FLANGIA	FLANGE	
3	2	TIRANTE	ROD	
4	1	INDOTTO	ARMATURE	
5	1	CARCASSA	PUMP FRAME	
6	2	O-RING	O-RING	
7	1	CALOTTA	BRUSH HOLDER	
8	1	CUSCINETTO	BALL BEARING	
9	1	ANELLO ONDULATO	COMPENSATION SPRING	X
10	2	O-RING	O-RING	
11	2	RONDELLA	WASHER	
12	2	DADO	NUT	
13	1	LINGUETTA	KEY	
14	1	INGRANAGGIO TRAINANTE	DRIVING GEAR	
15	1	INGRANAGGIO FOLLE	IDLE GEAR	X
16	1	O-RING	O-RING	
17	1	PIATTELLO	TOP PLATE	
18	4	VITE	SCREW	
19	1	SENSORE DI PRESSIONE	ELECTRONIC CONTROL	X
20	1	TAPPO DI SFIATO	AIR VENT CAP	X
21	3	O-RING	O-RING	X
22	1	VALVOLA DI NON RITORNO	NON RETURN VALVE	X
23	2	PORTAGOMMA	TUBE OUTLET	
24	4	O-RING	O-RING	X
25	1	NIPPLO	NIPPLE	
26	1	FILTRO	FILTER	X
27	4	ANTIVIBRANTE	ANTIVIBRATION MOUNT	X
28	4	INSERTO ANTIVIBRANTE	ANTIVIBRATION INSERT	X

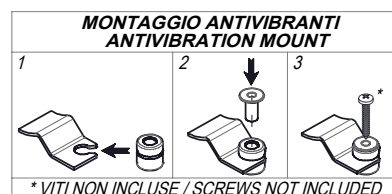
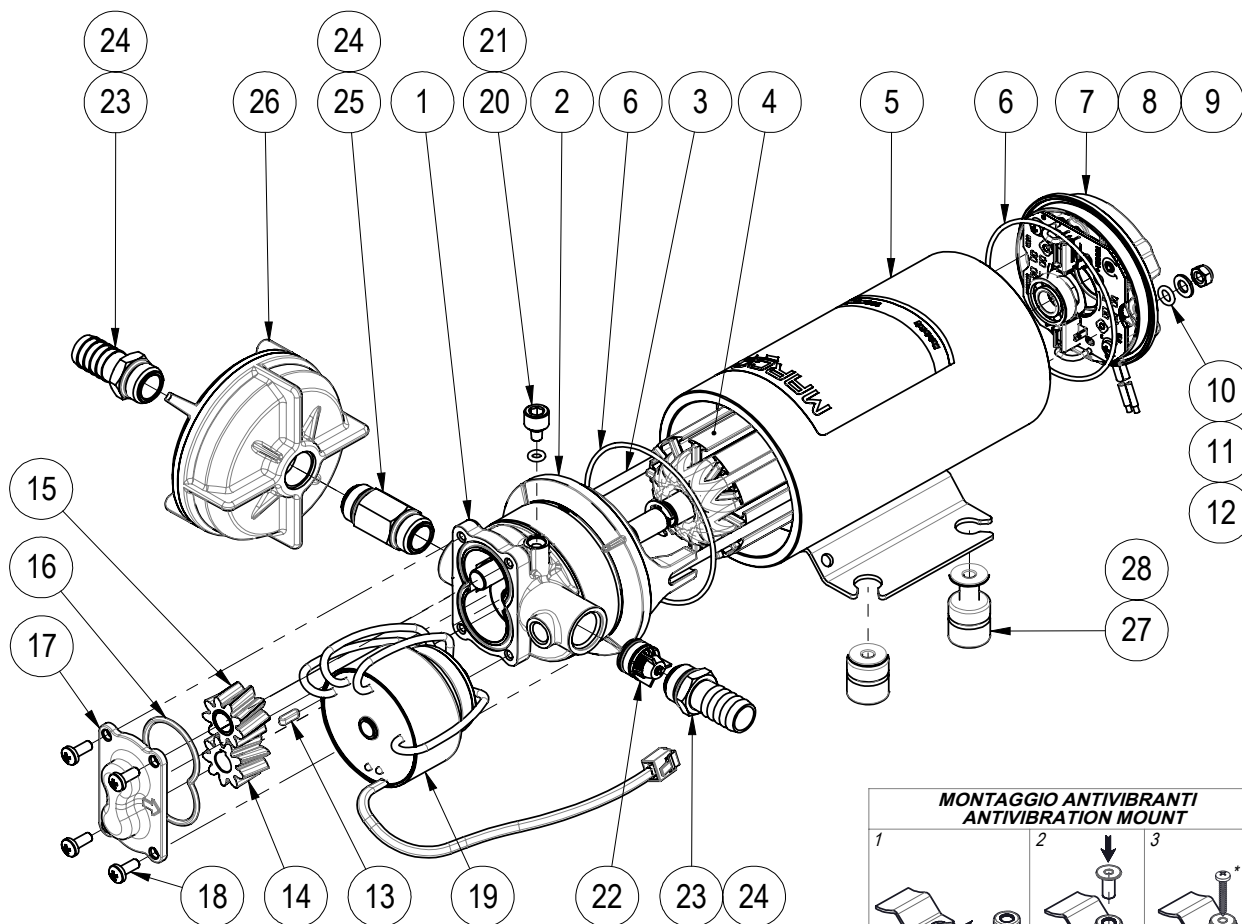

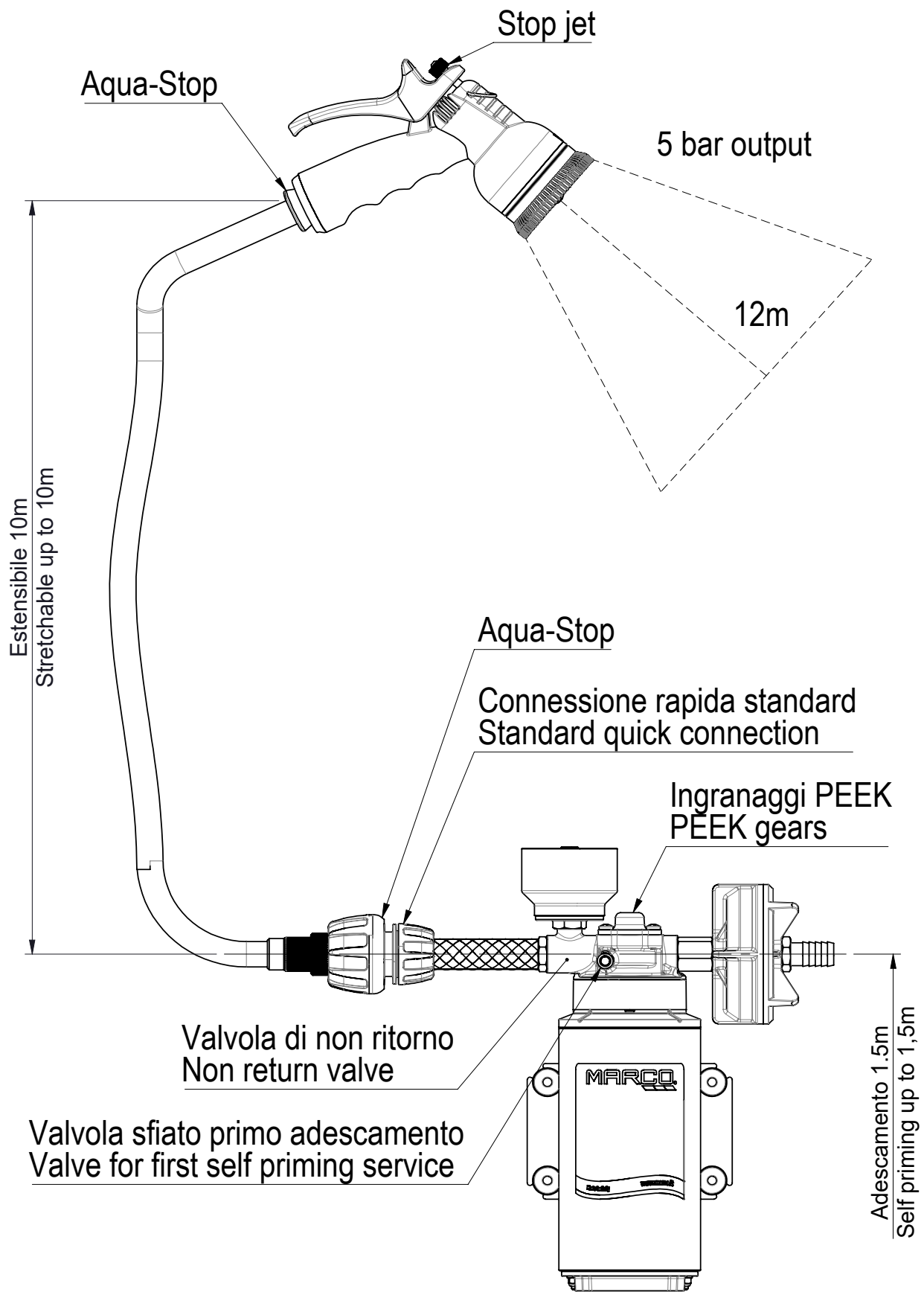

DIMENSIONS

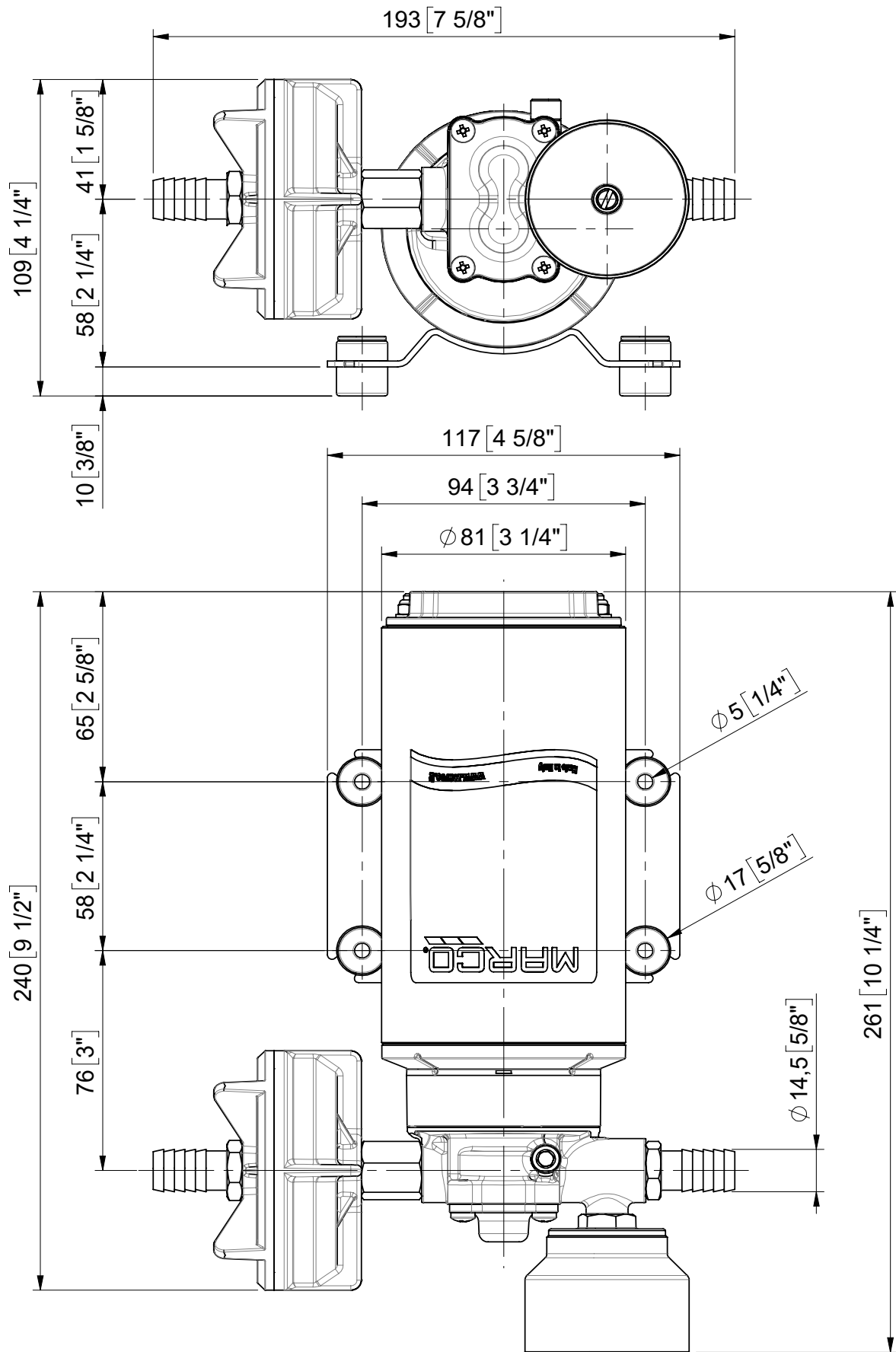

WATER DIAGRAMS

AMPERE-DRAW DIAGRAM

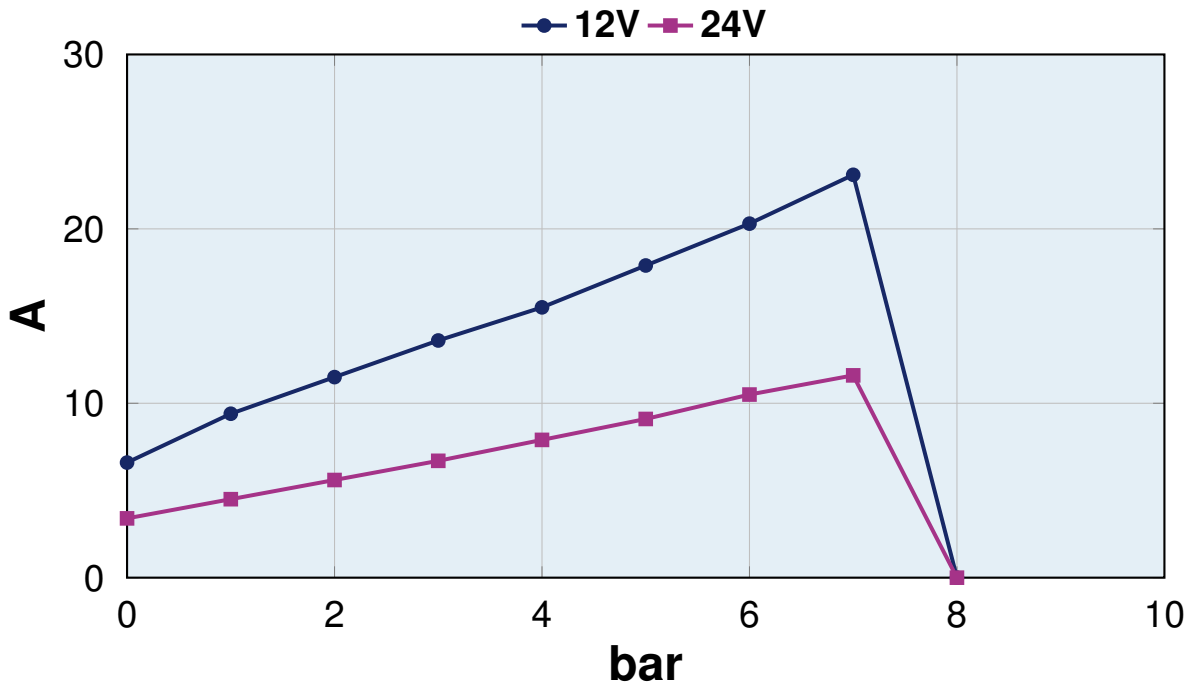

FLOW RATE DIAGRAM

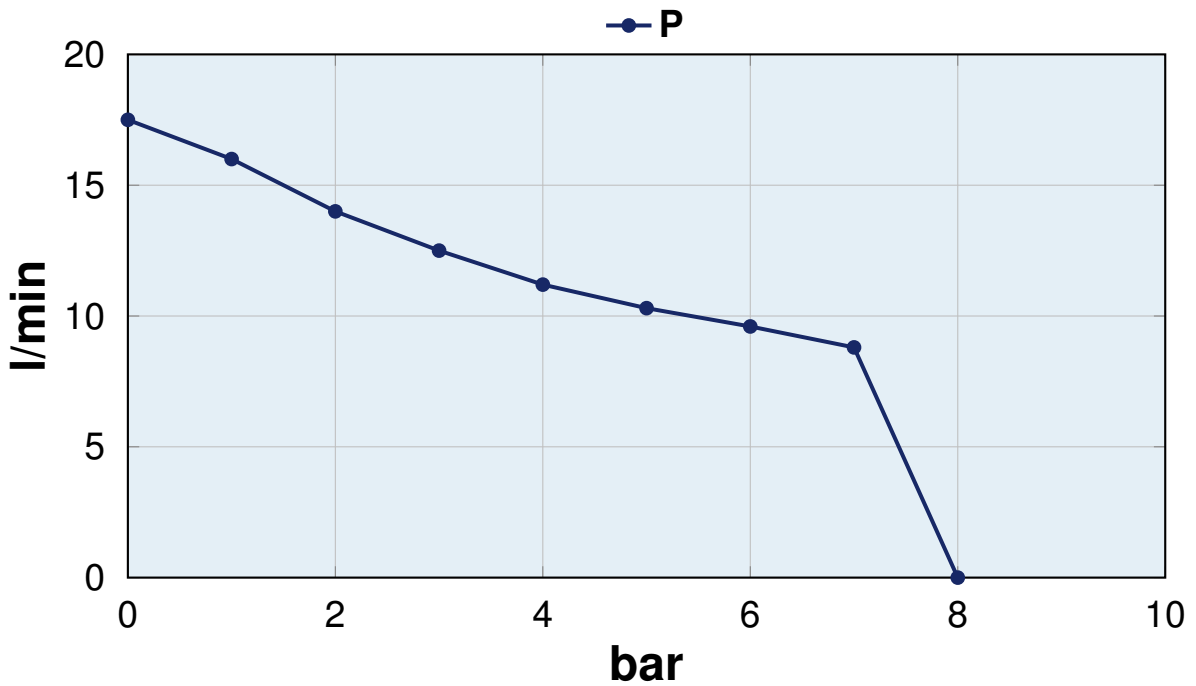



E.C. DECLARATION OF CONFORMITY

We confirm that the product:

1E483115 - DP10/E-MS 12/24V Washing Pump Mechanical Seal, Electronic Control 10 bar / gear pump

is in conformity with the Directive 2014/30/EU (ex.2004/108/EC) relating to electromagnetic compatibility and with the Directive 2006/42/EC relating to the machines.

This declaration is valid for all products which are produced in accordance with the technical documentation which is a part of this declaration. For verification of conformity with regard to the Electromagnetic Compatibility the following standards are applied:

EN 55014-1 Electromagnetic compatibility.
Requirements for household appliances,
electric tools, and similar apparatus.
Part 1: Emission.

EN 55014-2 Electromagnetic compatibility.
Requirements for household appliances,
electric tools, and similar apparatus.
Part 2: Immunity.

This declaration is given under the sole responsibility of:

MARCO S.P.A.
Via Mameli 10 - 25014 Castenedolo - Brescia - Italy
Tel. 030/2134.1 Fax 030/2134.300

Italiano



English



Property of MARCO S.p.A reproduction prohibited.

All rights reserved.

For further information visit our web site - www.marco.it
MARCO S.p.A Via Mameli 10 - 25014 Castenedolo (Brescia) - Italy
tel. +39 030 2134.1 / Fax +39 030 2134.300