

kidzone®



Instruction Manual

Licensed Mercedes-Benz AMG GT 2 Seater Ride On (12V)

Item number: 060-ROT-23L

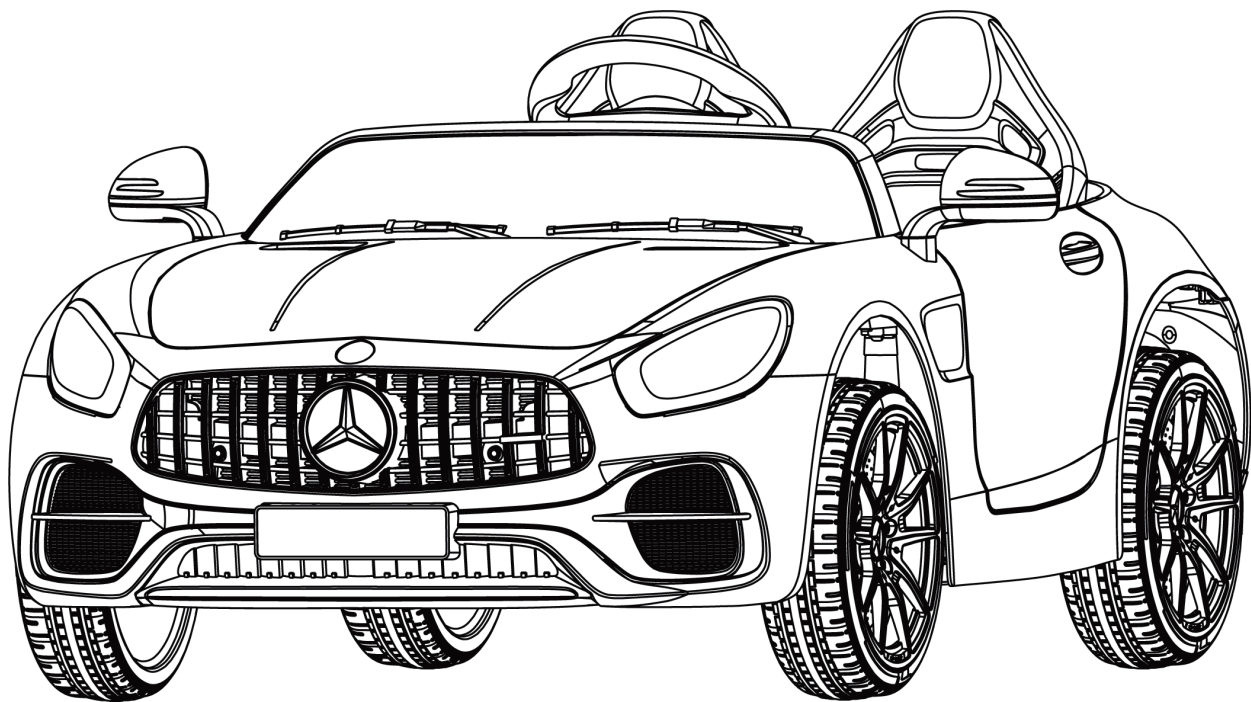

Note: Product appearance and colors may vary from the photo.

⚠ ATTENTION



**This vehicle is packed with the battery disconnected.
Connect the battery before use.**

**This manual contains important safety, performance
and maintenance information. Read the manual before
allowing your child to ride your new electric ride-on toy.
Keep this manual properly for future reference.**

Safety Instruction

When using electrical product, basic safety precaution should always be followed including the following

Read all Instruction before operating this product

⚠ WARNING:

- **To Protect against electrical shock, do not immerse cord, charger, transformer, battery, or the product in water or other liquid.**
- **Only use charging devices, transformer, and battery provided or recommended by the manufacturer.**
- **For your children's safety, the product should be assembled by adult.**
- **This toy is not intended for children below 36 months old.**
- **Closely adult supervision is necessary when your child is operating this product.**
- **Disconnect the battery if not used for a long time.**
- **Do not use this product as a traffic tool.**
- **To reduce the risk of injury, adult supervision is required. Never use in roadways, near motor vehicles, on or near steep inclines or steps, swimming pools or other bodies of water; always wear shoes, and never allow more than 2 riders.**
- **Do not use this product on slippery surface.**
- **Always keep hands, hair, and clothing away from moving parts.**
- **Maximum users' weight for this product is 88 lb / 40 kg.**
- **Do not change, modify or add any electrical wiring on this product.**
- **Avoid using this product in tight environment to prevent damage to the product or injury to the user.**
- **Do not use this product in the dark. Only operate this product during daytime or well-lit area.**
- **For your child's safety, please make sure the seat belt is securely fastened when operating this product.**
- **Personal protective equipment such as helmet is needed when operating this product.**

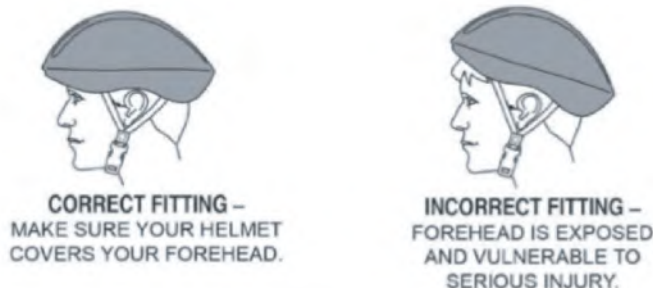

⚠ WARNING: Avoid continuously hitting into obstacle to prevent overheat or damage to the motor, drive away or remove obstacle as soon as possible.

⚠ WARNING:

PREVENT FIRE

- **Never modify the electrical system. Alterations could cause a fire resulting in serious injury and could also ruin the electrical system.**
- **Use of the wrong type of battery or charger could cause a fire or explosion resulting in serious injury.**
- **The battery must be handled by adults only. The battery is heavy and contains sulfuric acid(electrolyte). Dropping the battery could result in serious injury.**
- **Never allow children to charge the battery. Battery charging must be done by adults only.**
- **Never lift or carry the battery by the wires or connector. This can damage the battery and possibly cause a fire resulting in serious injury. Lift and carry the battery by the case only.**
- **Examine the battery, charger and their connectors for excessive wear or damage each time you charge the battery. If damage or excessive wear is detected, do not use the charger or the battery until you have replaced the worn or damaged part.**

⚠ WARNING:

Manufacturer and seller expressly disclaim any and all liability for personal injury, property damage or loss, whether direct, indirect, or incidental, resulting from the incorrect attachment, improper use, inadequate maintenance, unapproved modification, or neglect of this product.

⚠ WARNING

FAILURE TO FOLLOW THE SAFETY INSTRUCTIONS LISTED BELOW MAY RESULT IN SERIOUS INJURY OR DEATH

The owner's manual contains assembly, use and maintenance instructions.

Child Safety Warnings

- **Adults supervising children must read and understand this entire manual before allowing any child to use this product.**
- **Adults must evaluate their own children as to maturity, strength, judgment and ability to follow safety rules. Published age guidelines are not a substitute for careful evaluation of your own child.**
- **Adults must teach children about thinking ahead while riding as this may be the first time a child has ever controlled a motorized ride-on toy. While you supervise, see through the child's eyes, and verbally teach them about steering and avoiding obstacles in the approved riding area.**

⚠ WARNING

- **Riding a motorized ride-on toy can be a dangerous activity, even under the best of circumstances. Good choices regarding where and when to ride, constant adult supervision of riding, and practice and careful riding by the child can all help to minimize risk. However this ride-on toy is intended to move and therefore it is possible for the rider to lose control, fall off and/or get into dangerous situations that no amount of care, instruction or expertise can eliminate.**
- **If this inherent risk is not acceptable, adults should not allow children to ride this ride-on toy.**

⚠ WARNING

Safe Riding Warnings

- **Not to be used by children under 36 months or children over 72 months.**
- **Do not exceed the maximum weight capacity of 88 lb (40kg).**
- **Do not allow more than 2 riders.**

ADULTS AND SUPERVISORS, PLEASE NOTE:

- 1. Always instruct all children of common sense rules and safe practices.**
- 2. Be aware that flat, hard surfaces provide the safest experience for child riders.**
- 3. Do not allow the child rider to operate the ride-on toy near streets, roads, sidewalks, walkways, or any other place where they may encounter other moving vehicles.**
- 4. Never leave children unattended with this ride-on toy. Continuous adult supervision is required.**
- 5. If necessary, adults and supervisors are always responsible for setting up gates and barriers to ensure a safe riding environment for the child rider.**
- 6. Be aware that this ride-on toy does not have braking capabilities. Allowing use of this ride-on toy in areas that require braking may cause rolls, crashes, serious injury, or death to the child rider.**
- 7. Teach children not to allow other children to use this ride-on toy. Communicate this message to other adults and supervisors of fellow children with which your child interacts.**
- 8. Sternly alert children that hands, legs, hair, and clothing can potentially get caught in moving parts. Ensure they never place a body part or piece of clothing near a moving part of the ride-on toy. Avoid loose clothing.**
- 9. Instruct children to always wear shoes when using the ride-on toy.**
- 10. Confirm that children do not have access to the charging equipment or come into contact with any part of the ride-on toy while it is charging.**

WARNING

- 11. Do not mix old and new batteries.**
- 12. Do not mix alkaline, standard (carbon zinc), or rechargeable batteries.**
- 13. Firmly instruct children to use the ride-on toy in a safe manner. Unsafe behaviors include, but are not limited to:**
 - **Traveling at unsafe speeds**
 - **Not riding in the seated position**
 - **Riding at night or in any conditions of low visibility**
 - **Riding in any wet conditions including rain, snow, and ice**
 - **Any kind of stunt riding: jumps, ramps, stairs, hills, sloped surfaces, or other actions involving any notable risk**
 - **Riding near any pool or open body of water**
 - **Pushing, pulling, or shoving the driver in any way while operating the ride-on toy**
 - **Using the ride-on toy without the battery cover or any other safety cover fully closed**
 - **Pulling or hitching the ride-on toy with other similar moving ride-on toys or products**

WARNING

Battery and Charging Warnings

The following safety hazards may result in serious injury or death to the user of the ride-on:

- **Do not mix old and new batteries.**
- **Do not mix alkaline, standard (carbon-zinc), or rechargeable (nickel-cadmium batteries.)**



Corrosive Material Warnings

- **Battery posts, terminals and related accessories contain lead and lead compounds (acids) chemicals and are toxic and corrosive. Never open the battery.**
- **Contact or exposure to battery leakage (lead acid) may cause serious injury. If contact or exposure occurs with the skin or in the eyes, or if the chemical is swallowed, immediately call 911.**

⚠ WARNING



Flammable and Explosive Materials Warnings

- **Use of a battery or charger other than the supplied rechargeable battery and charger may cause a fire or explosion. Only use the supplied rechargeable battery and charger with the ride-on toy.**
- **Do not charge the battery near heat or flammable materials.**
- **Using the rechargeable battery and charger for any other product may result in overheating, fire or explosion. Never use the rechargeable battery and charger with another product.**
- **Contact between the positive and negative terminals may result in fire or explosion. Avoid direct contact between the terminals. Lifting the battery by the wires or charger can cause damage to the battery and may result in a fire. Always lift the battery by its case or handles.**
- **Plug wall charger directly into a wall outlet. Do not use an extension cord when charging as the use of an extension cord can cause a fire.**



Electric Shock / Fire Warnings

- **Liquids on the battery may cause fire or electric shock. Always keep all liquids away from the battery and keep the battery dry.**
- **Tampering or modifying the electric circuit system may cause a shock, fire or explosion and permanently damage the system. Exposed wiring, circuitry in the charger may cause electric shock. Always keep the charger housing closed.**
- **Regularly check charger, supply cord and connector for wear and damage. Look for frayed or kinked wires, any exposed inner wires, any missing insulation. If any damage is observed do not plug in the charger and do not charge the battery.**

CAUTION

Re-Charge Interval and Time Important!

- **Damage to the battery may occur if it is allowed to drain completely. Do not allow the battery to drain completely.**
- **Check the battery and charger (supply cord, connector) for wear and damage before charging. Do not charge the battery if damage has occurred. Do not use an extension cord when charging the ride-on toy.**
- **On average you will need to charge the battery for 8-12 hours and no more than 20 hours. Failure to charge the battery as directed could cause permanent damage to the battery and void the warranty.**
- **Only an adult who has read and understands the safety warnings should handle, charge and recharge the battery.**

WARNING

Product Warning

WARNING:

This product can expose you to chemicals including lead, and lead components which is known to the State of California to cause cancer and birth defects or other reproductive harm. For more information go to www.P65Warnings.ca.gov.

Assembly Warnings

- **The ride-on toy must be assembled by an adult who has read and understands the instructions in this manual.**
- **Choking hazard to children under the age of 3 years.**
This ride-on toy contains small parts that are for adult assembly only. Keep small children away when assembling.
- **Remove and dispose of all protective materials, plastic bags and packaging before assembly.**

Product Specification

Motor: 12V, 45W*2, 12000rpm

Battery: 12V7AH x1

Charger: 15V1000mA

Speed: 0.7 – 3.1 mph

Suitable Age: 37 - 72 months

Maximum User Weight: 88 lb / 40 kg

Dimension: 46 x 29 x 19 INCH / 116.8 x 73.7 x 48.3 CM

Battery Charge Time: 8 - 12 hours

Operation Time: 1 - 2 hours

First Charging Time: 8-12 hours

Max Charging Time: 20 hours

Battery (Temperature Tolerance): -68°F to 140°F

Parts and Feature

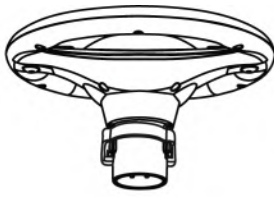

A (Steering Wheel)

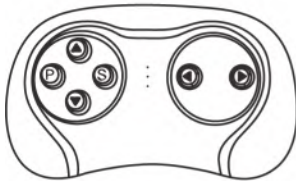

E (Remote Control)

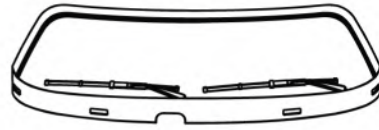

F (Wind Shield)



H (Wheel Cover)



J (Wheel)



L (Rear View Mirror L)



R (Rear View Mirror R)

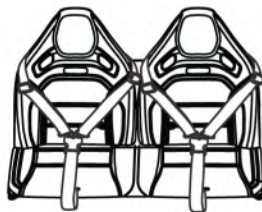

N (Seat)

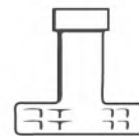

P (M8 Spanner)



X (Self-Tapping Screw)

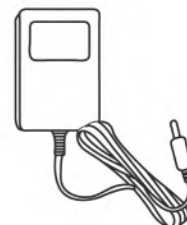

Q (Charger)

Assembly Instruction

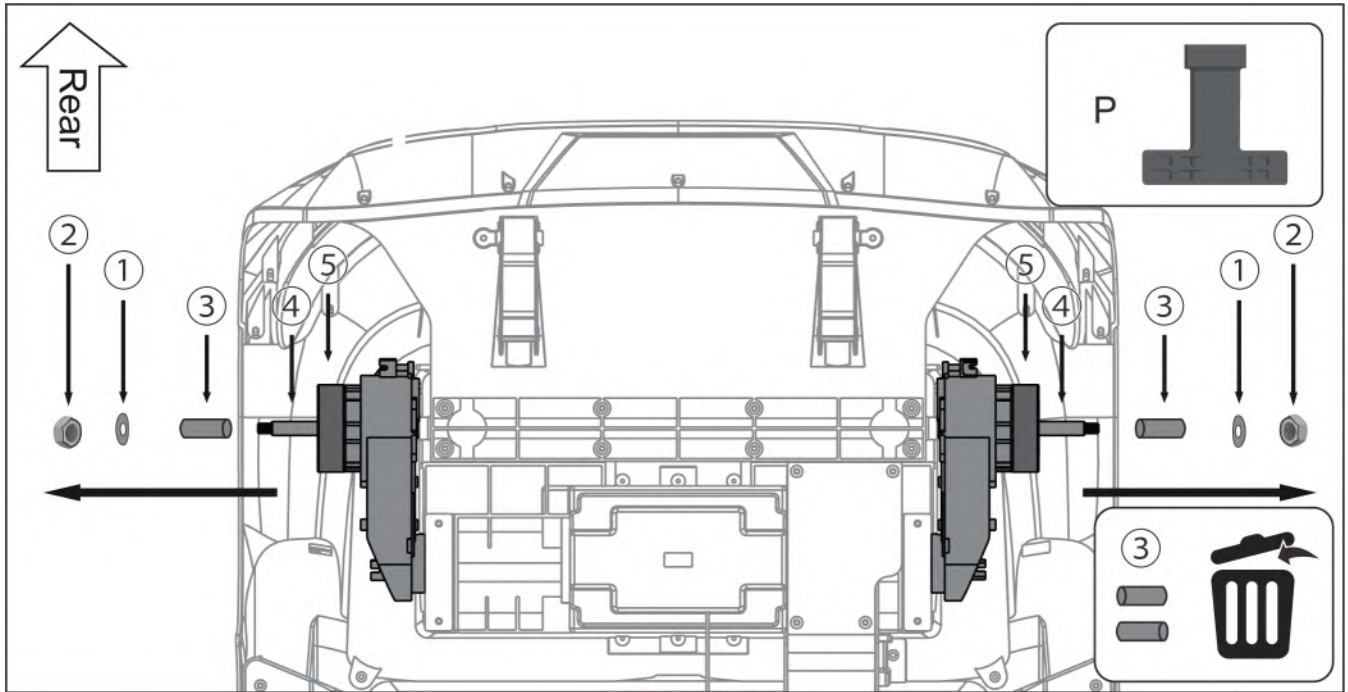

Use the spanner (P) to loosen the M8 nut (2) and gasket (1) from the rear axle. Remove and put the protective cover (3) from the axle in the trash.

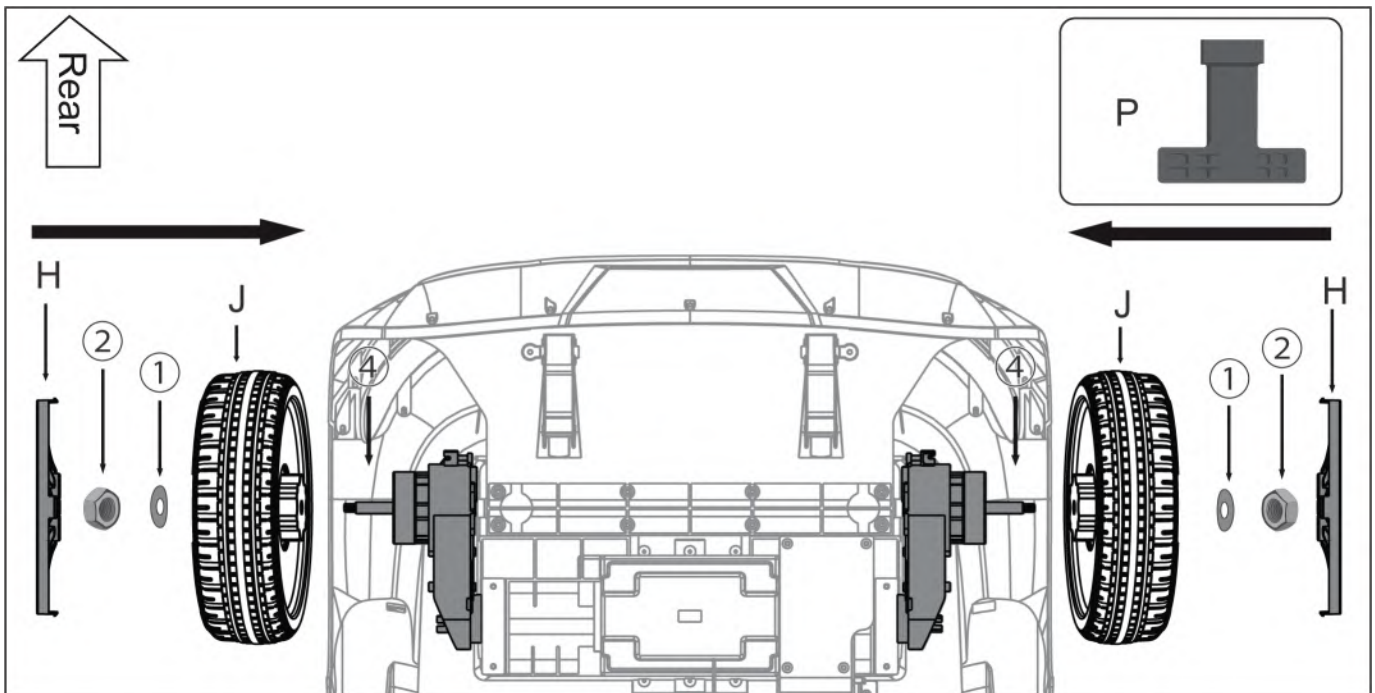

Install the wheel (J) to the rear axle (4). Use spanner (P) to secure the wheel with M8 gasket (1) and M8 nut (2) and cover the wheel with wheel cover (H).

Assembly Instruction

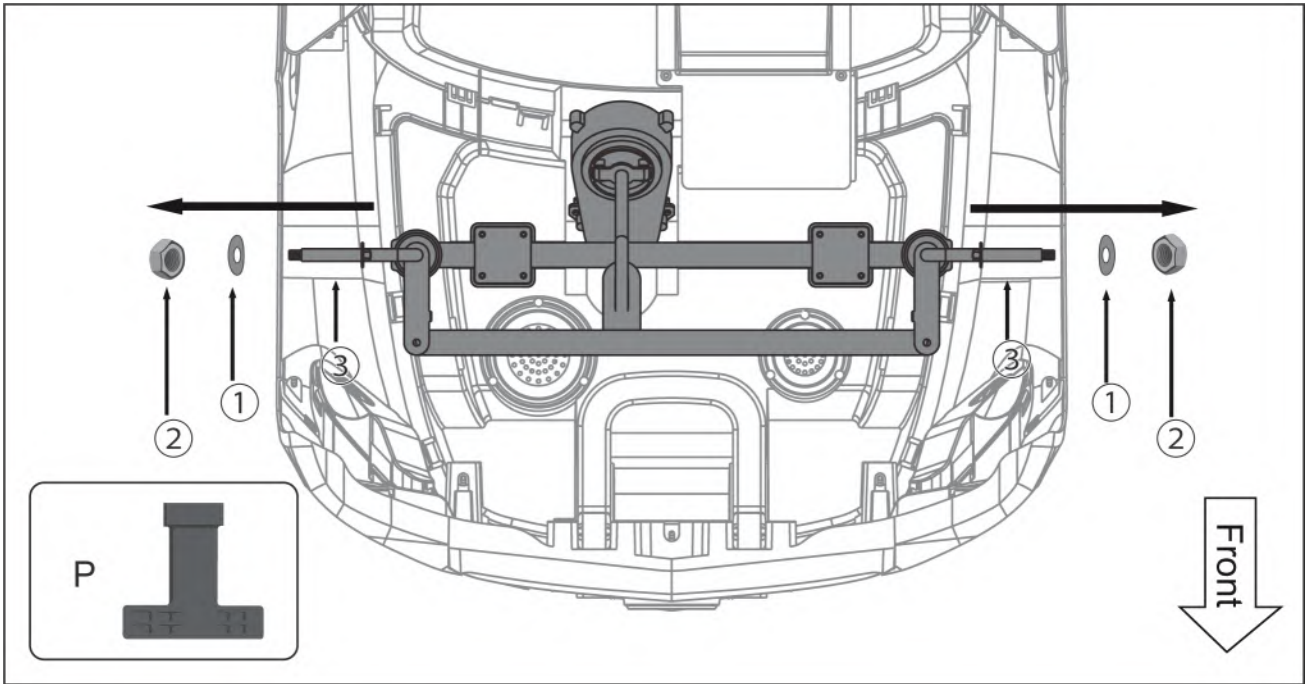

Use the spanner (P) to loosen the M8 nut (2) and M8 gasket (1) from the front axle (3).

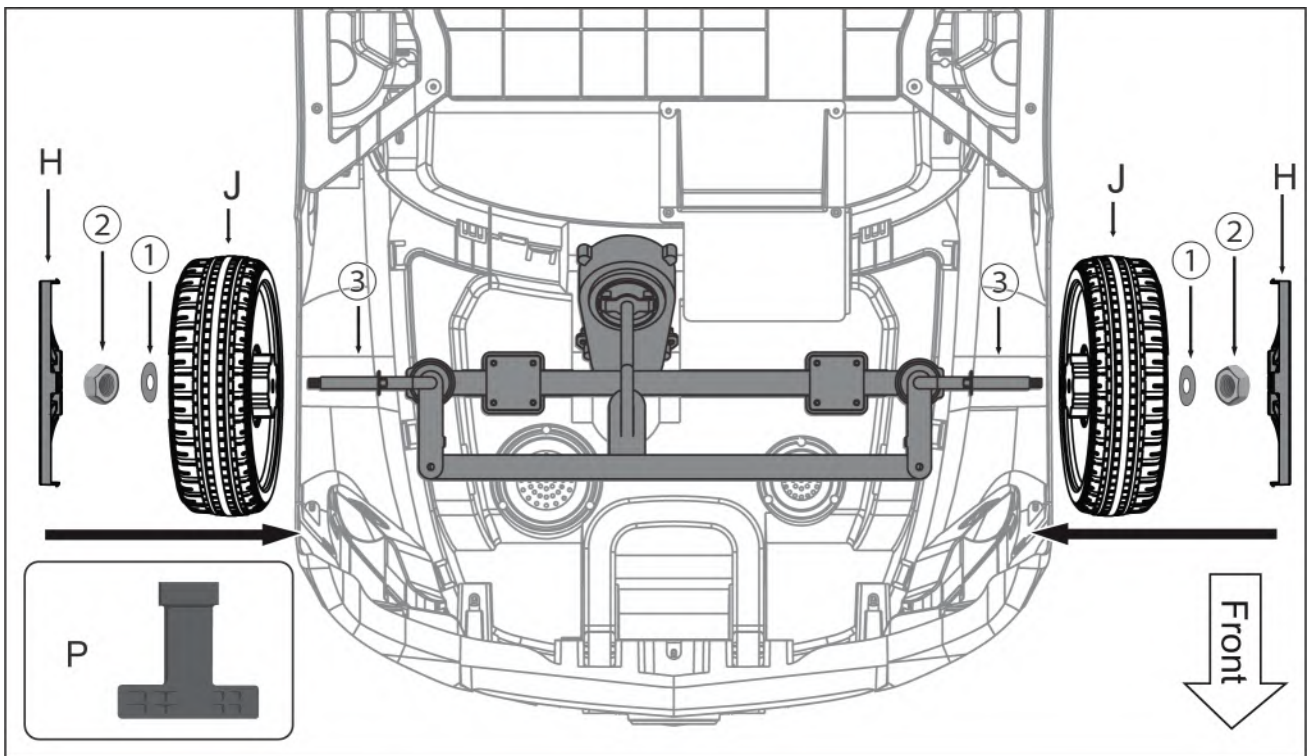

Slide the wheels (J) to the front axle (3). Use spanner (P) to secure the wheel with M8 gasket (1) and M8 nut (2) and cover the wheel with wheel cover (H).

Assembly Instruction

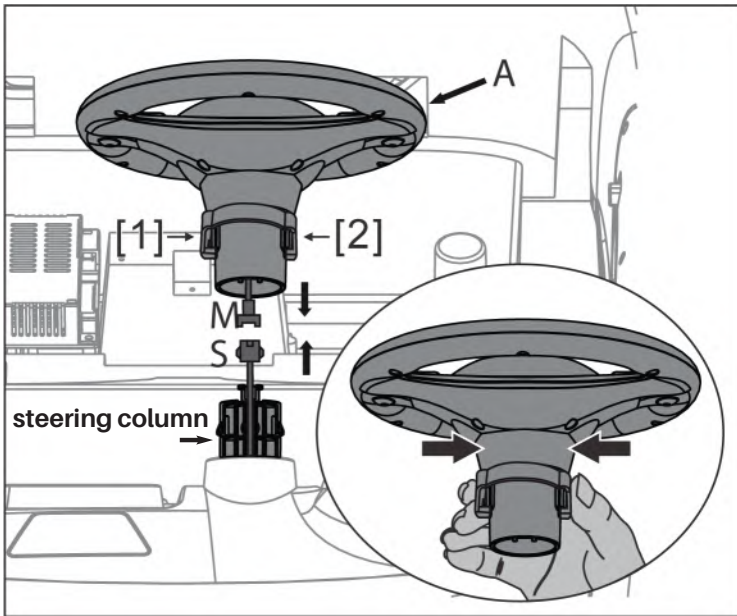

Connect the steering wheel terminal (M) and the body terminal (S), then align the steering wheel (A) to the steering column and connect as shown in the diagram.

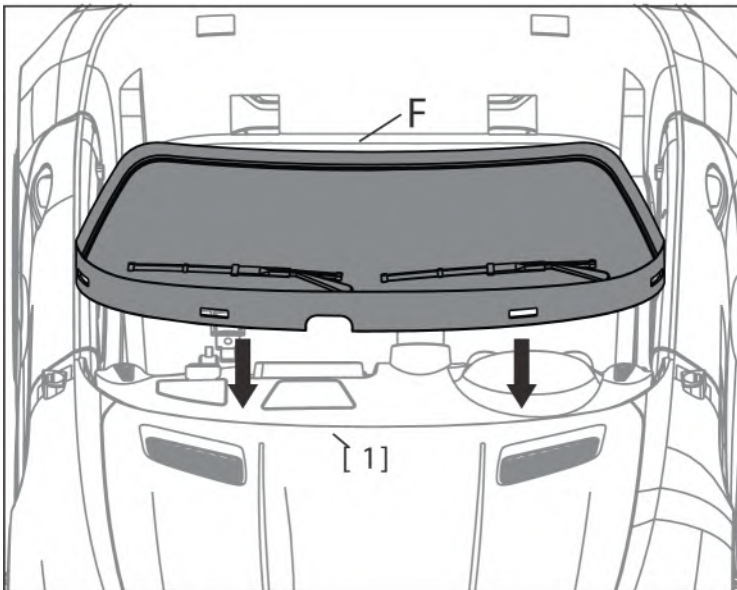

Assemble the wind shield (F) to the corresponding groove on the car body.

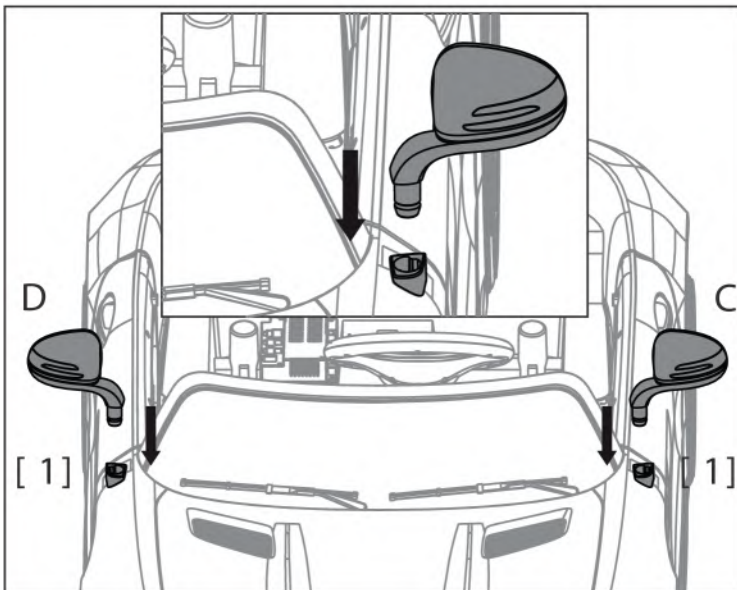

Align and insert rear view mirror (C) (D) to the car body.

Assembly Instruction

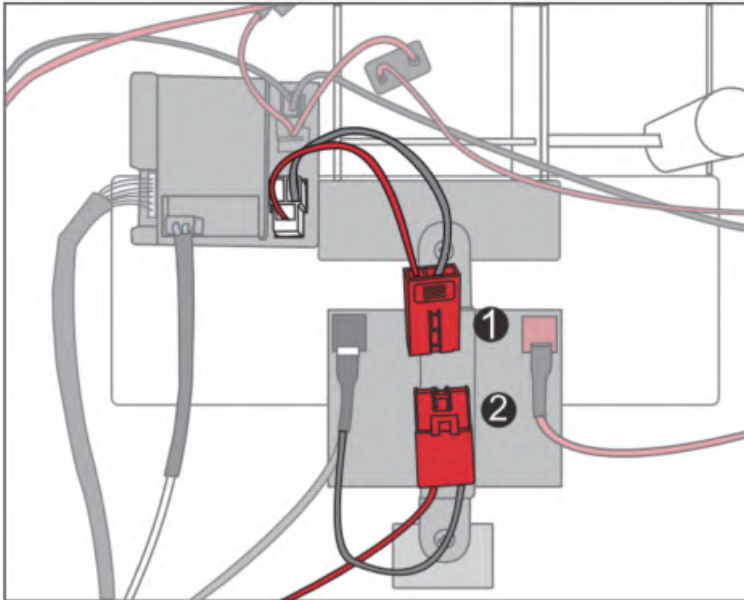

First find out the 2 red power terminals under the seat and connect them.

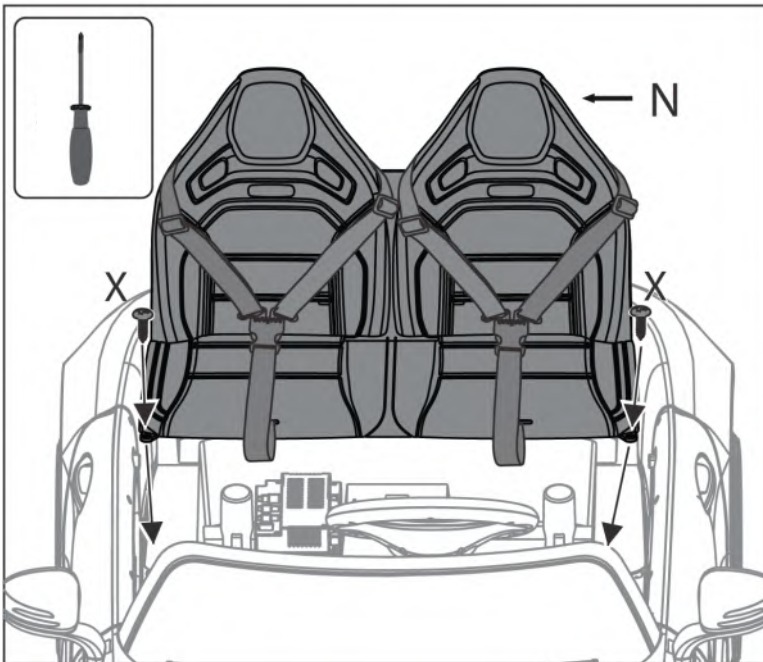

Assemble the seat (N) to the car body and secure it in place with 2 self - tapping screws (X) by screwdriver .

User Instruction

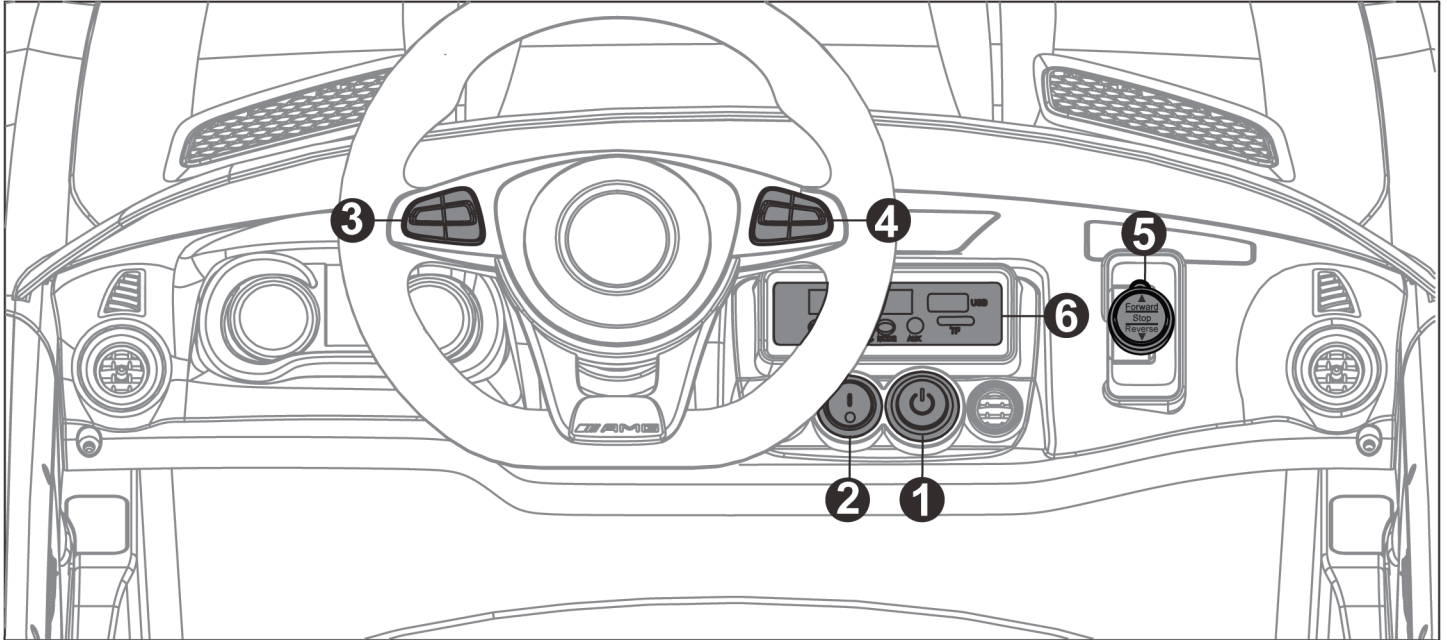

Control the vehicle

1. Start Switch

Turn the product on and off .

2. Light Switch

Turn the light on and off.

3. Music Button

In the FM mode or USB mode, press the button once to play the next track. Press and hold to increase volume.

4. Horn Button

Press the button the horn.Press and hold the button to decrease volume.

5. Forward / Reverse Switch

Press the switch to control the vehicle to move forward / reverse.

⚠ WARNING: Do not change the speed or direction until the vehicle comes to a complete stop.

6. MP3 multifunctional player

User Instruction

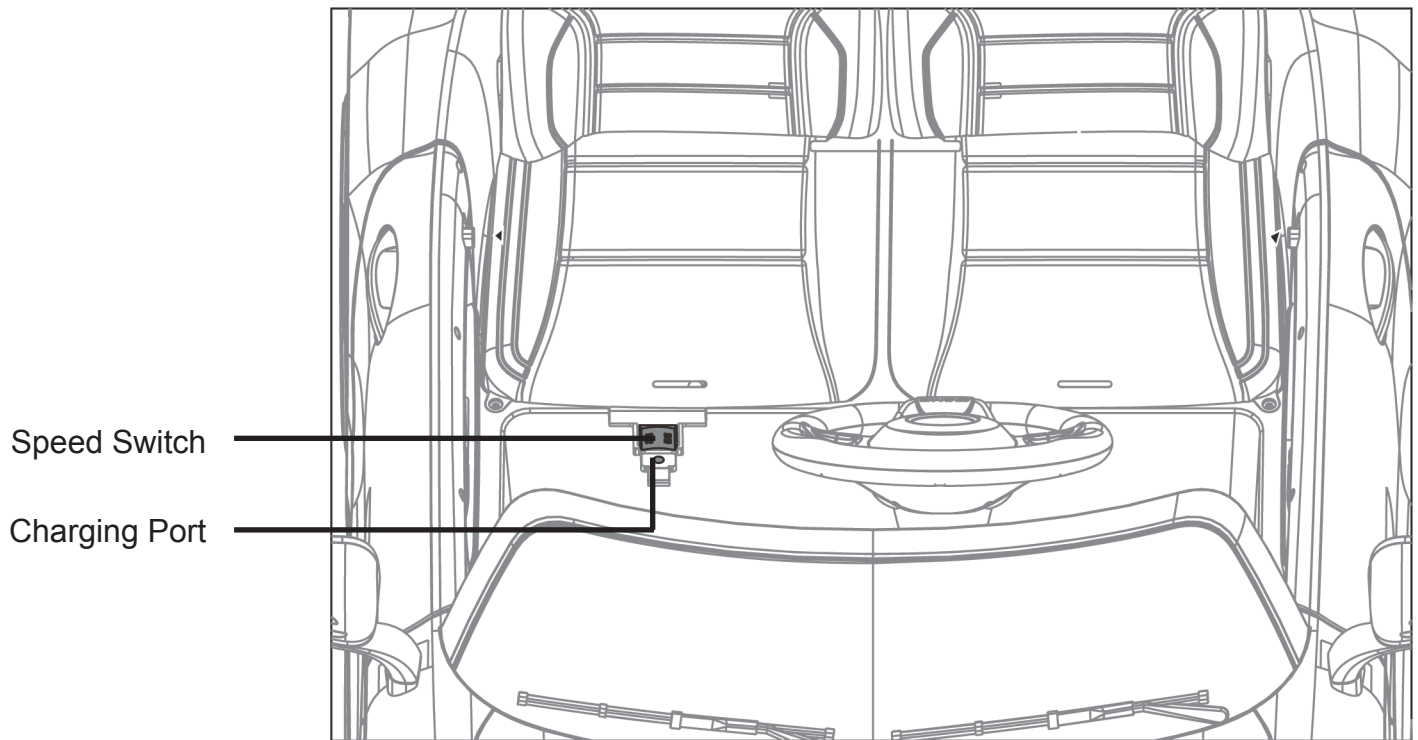

Speed Switch

Control the speed of the vehicle in slow or fast.

NOTE: The vehicle can only be operated in slow for reverse.

User Instruction (Fuse)

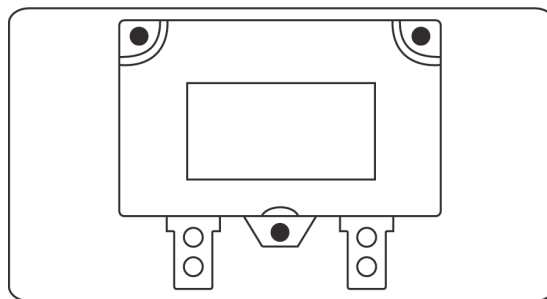

Resettable Fuse

When the current exceeds a preset value, the fuse will cut off the power for 5 - 10 seconds before current resume.

⚠ WARNING: Do not bypass the fuse. The fuse is designed to protect the product from overload and electrical system damage.

User Instruction (Multifunction Player)

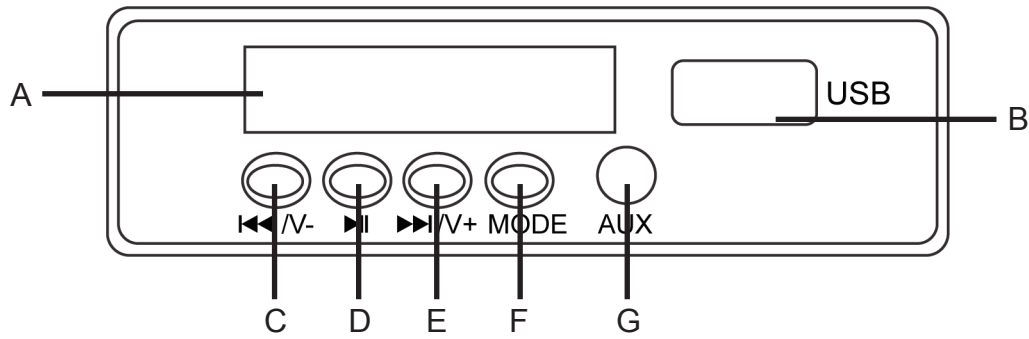

A. Battery Level Screen

The screen display battery level.

B. USB connector

insert USB to play the music.

NOTE: Only support MP3 file format.

C. Previous Track / Decrease Volume

Press the button once to play the previous track. Press and hold to decrease volume.

D. Play / Pause

Press the button to pause.

Press and hold the button to search radio station in FM mode.

E. Next Track / Increase Volume

Press the button once to play the next track. Press and hold to increase volume.

F. Mode Button

Press the mode button to cycle through different modes.

G. AUX port

Connect an external device to play audio file via AUX cable to the AUX port.

User Instruction (Remote Control)

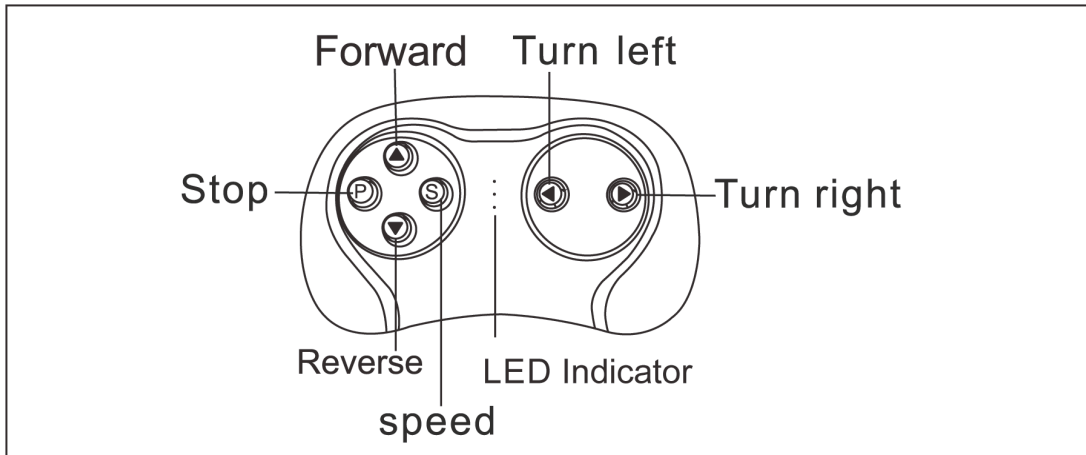

Using the remote control

The remote control should only be used by adult.

To pair the remote control to the vehicle,

1. Put in the battery and the LED indicator on the remote control will flash.
2. Turn on the power of the vehicle.
3. Successful pairing when the LED indicator stop flashing.

Control the vehicle

- Press the directional buttons to move the vehicle.
- Press the "P" button to enable emergency brake. **All running function will be disable once the button is pressed.** Press "P" button again to disable.
- Press "S" button to adjust the speed.

⚠ WARNING:

Close supervision is needed when children is operating the vehicle.

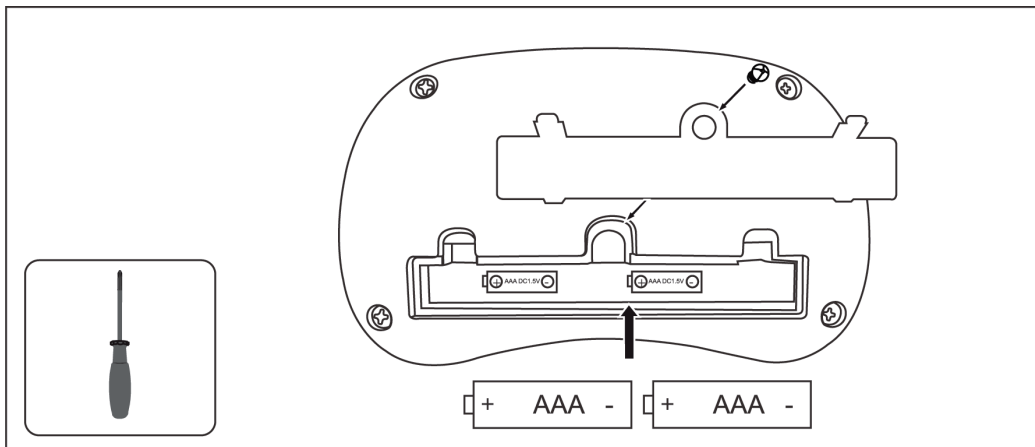

⚠ WARNING:

The battery should only be changed by an adult.

Changing the battery

1. Remove the cover on the back side with a screwdriver.
2. Replace the old battery with two new AAA 1.5V batteries in correct polarity.
3. Put the cover back in place and secure with the screw.
4. Do not mix old and new batteries.
5. Do not mix alkaline, standard (carbon-zinc), or rechargeable batteries.

NOTE: If the remote controller is not used for 10 seconds, it will shut down automatically.

User Instruction (Charging)

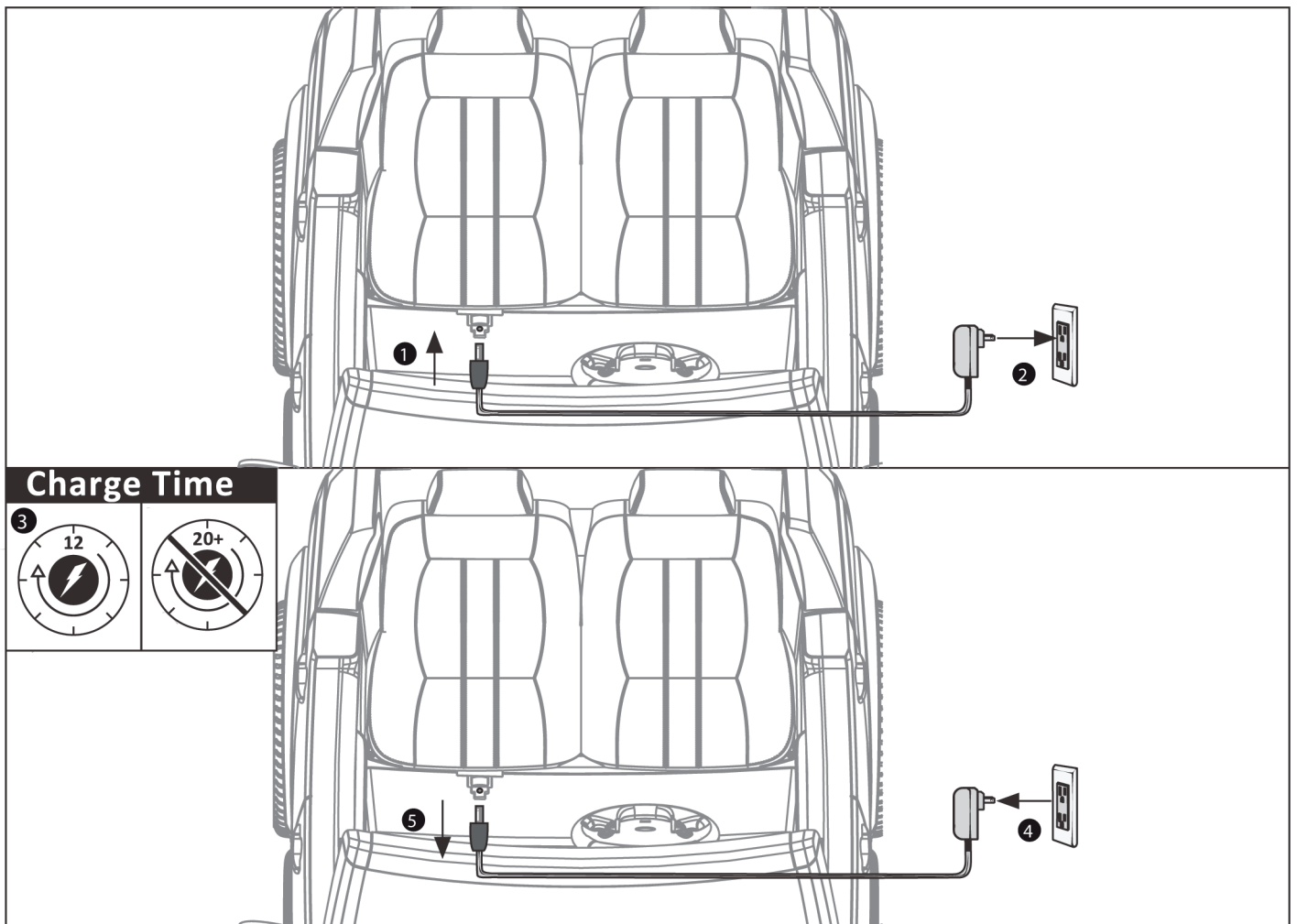

⚠ WARNING:

The battery should only be charged by an adult. The battery is not replaceable.

Charging the battery

1. Insert the charging cable to the charging port located below the vehicle seat.
 2. Insert the charger plug into a wall outlet.
- The vehicle must be OFF when charging.
 - Recharge the battery if the vehicle operates slowly.
 - The vehicle cannot be operated when charging.

NOTE:

Damage to the battery may occur if it is completely drained.
Do not charge the battery for more than 20 hours.

NOTE: Charge the battery at least once a month even not operating the vehicle to maximize the battery life.

User Instruction (Pull Rod)

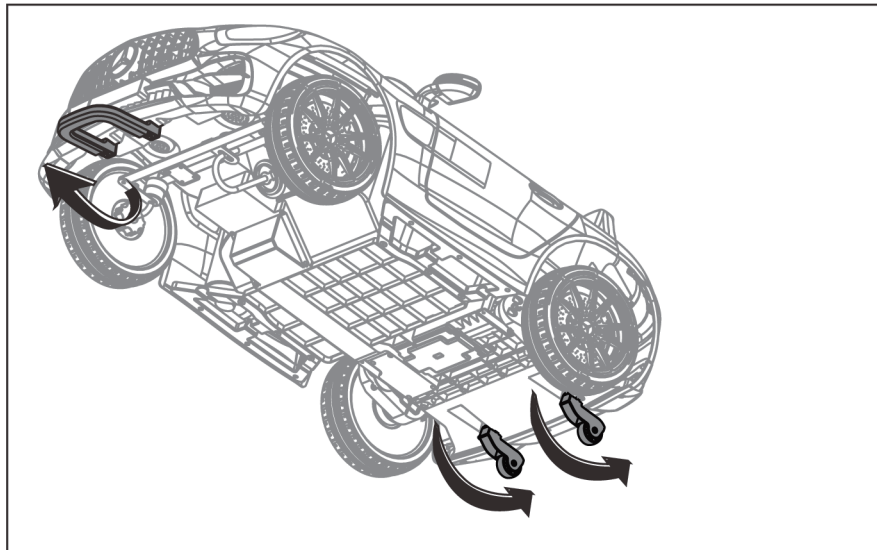

Unfold the pull rod and caster rollers from the bottom of the vehicle.

Care and Maintenance

- Check the product regularly and make sure there is no missing or loose parts. Re-tighten any loose parts if necessary.
- Make sure there is no cracked or broken plastic parts.
- Keep away the product from heat and humid area, cover it with trap when not in use.
- Turn off the product and disconnect the battery if the product is not used for a long period of time.
- Clean the vehicle with a cloth. Use a non-wax furniture polish to restore the shininess of the plastic parts. Do not use abrasive cleaner.
- Do not wash the product with a hose or immerse any parts in water or other liquid.
- Occasionally use lightweight oil to lubricate moving parts

Troubleshooting

Problem	Possible Reason	Solution
Vehicle does not move	Low Battery	Fully charge the battery
	Fuse Protection	Replace with a new fuse
	Disconnected / Badly connected battery	Reconnect the battery
	Failed battery / engine	Contact Customer Service
Battery not last long	Low Battery	Fully charge the battery
	Old Battery	Replace battery if necessary
Vehicle runs very slow	Low Battery	Fully charge the battery
	Old Battery	Replace battery if necessary
	Vehicle is overloaded	Make sure user's weight is under 88 lb / 40 kg
	Vehicle is being used in harsh environment	Avoid using the vehicle in harsh environment

Troubleshooting

Problem	Possible Reason	Solution
Vehicle needs a push to go forward	Poor wire connection	Check if the battery connectors are firmly connected. Contact Customer service if necessary
	"Dead spot" on motor	Contact customer service
Loud grinding sound or clicking sound from the motor or gear box	Damaged motor or gear box	Contact customer service
Battery does not charge	Disconnected / Badly connected battery	Reconnect the battery
	Disconnected / Badly connected charger	Make sure the charger is firmly plugged into the power source and connected to the charging port
	Charger not working	Contact customer service
Charger becomes warm during charging	Normal	N/A

Model: 2ARLM-CST-1A

FCC ID: CST-1A

This device complies with part 15 of the FCC Rules. Operation is subject to the following two conditions:

(1) This device may not cause harmful interference, and

(2) this device must accept any interference received, including interference that may cause undesired operation.

NOTE: This equipment has been tested and found to comply with the limits for Class B digital device, pursuant to part 15 of the FCC rules. These limits are designed to provide reasonable protection against harmful interference in a residential installation. This equipment generates, uses and can radiate radiofrequency energy and if not installed and used in accordance with the instructions, may cause harmful interference to radio or television reception, which can be determined by turning the equipment off and on, the user is encouraged to try to correct the interference by one or more of the following measures:

- Reorient or relocate the receiving antenna.
- Increase the separation between the equipment and the receiver.
- Connect the equipment into an outlet on a circuit different from that to which the receiver is connected.
- Consult the dealer or an experienced radio/TV technical for help.

Caution: Changes or modifications not expressly approved by the party responsible for compliance could void the user's authority to operate the equipment.

This product conforms to toy safety standards CPSIA and ASTM-F963.

Importer: ONE BIG OUTLET

Importer Address: 19301 E Walnut dr. N. City of industry CA91748 united states

Importer Tel.: 800 - 946 - 6151

Limited Term Warranty (One Year from Date of Purchase)

WARRANTY TERMS

KIDZONE warrants that its merchandises are free from manufacturing defects (workmanship and/or material) and will either give credit or replace defective parts for a period of up to one (1) year from the date of purchase in accordance with the conditions set forth below. If a manufacturing defect is found, KIDZONE should be notified promptly of the defect and supplied a copy of the invoice and delivery ticket. Inspection by a KIDZONE employee or representative may be necessary to verify that a manufacturing defect exists, or you may be required to submit samples to KIDZONE along with a digital image of the defects. If replacement is required in accordance with this warranty and the defective material or merchandise has been discontinued or unavailable, KIDZONE reserves the right to select and supply similar merchandise or offer full credit for the merchandise; otherwise the same material or merchandise will be supplied for replacement purposes. This warranty is made solely to the retailer and is not transferable under any circumstances. It is the retailer's responsibility to contact KIDZONE with a claim. We will not handle claims from consumers directly; all requests must go through the retailer who sold the merchandise to the consumer. We advise all retailers to retain invoices for a minimum of one (1) year for warranty purposes. This warranty supersedes and replaces all implied warranties of merchantability and use for particular purpose. No representative, employee, agent or any other person is authorized to assume for KIDZONE any additional liability or responsibility in connection with KIDZONEs merchandise except as described above. Implied warranties or merchantability and fitness of the merchandise are limited to a period of one (1) year from the date of purchase. In no event shall KIDZONE be liable for indirect, consequential or incidental damages of any kind.

ADDITIONAL CONDITIONS

THE FOLLOWING EXAMPLES ARE NOT MANUFACTURER'S DEFECTS:

- Colors may vary slightly from the photo because of photography and printing tolerances.
- Sizes stated in U.S. standard measurements may vary slightly due to product are manufactured using the metric system.
- No returns for buyer's remorse.
- No returns - other than stated above will be accepted.

ADDITIONAL CONDITIONS

WARRANT IS VOID FOR ANY OF THE FOLLOWING CONDITIONS:

1. Improper maintenance or improper use resulting in damage.
2. Any product modifications by dealer, consumer, or other parties not authorized by KIDZONE will void this warranty.
3. Floor samples sold or products designated "AS IS" at the time of purchase are not covered by the warranty
4. Warranty does not cover minor variations or differences between floor samples or printed illustrations and your product.
5. Cost of packaging and shipping to and from KIDZONE is not covered by the warranty unless expressly arranged by KIDZONE.
6. This warranty covers only articles of appliances intended for residential use only, does not cover any industrial, commercial, institutional or Rental use.
7. Dissatisfaction due to buyer's remorse.
8. Normal wear and tear.
9. Damages incurred during transportation.
10. Damages incurred during assembling or maintenance.
11. Damage incurred by accidents or abuse.