

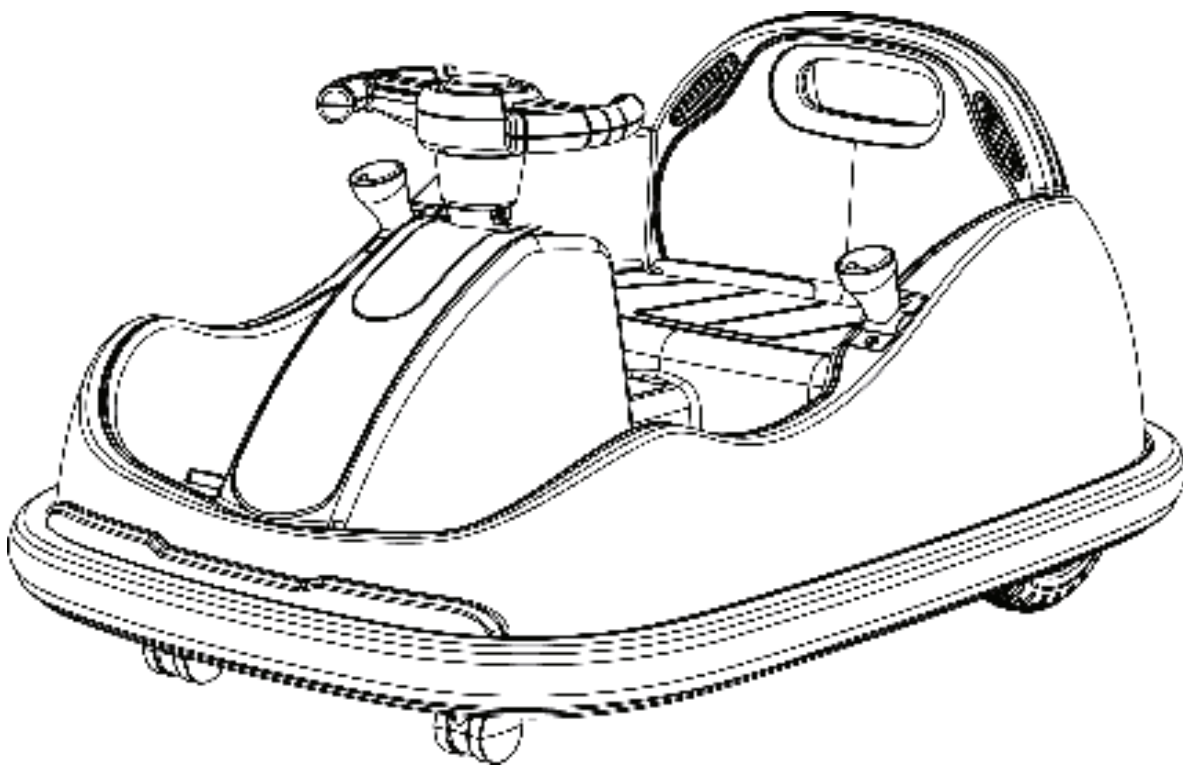

Instruction Manual

Ride On Bumper Car (2 Driving Modes) (12V)
item number: 060-ROT-07



*Product appearance and colors may vary from the photo.

⚠ ATTENTION



This vehicle is packed with the battery disconnected. Connect the battery before use.

This manual contains important safety, performance and maintenance information. Read the manual thoroughly before allowing your child to ride your new electric ride-on toy.

Failure to read the user manual can result in property damage or bodily injuries.

Keep this user manual for future reference.

Safety Instruction

When using electrical product, basic safety precaution should always be followed including the following:

Read all Instruction before operating this product

⚠ WARNING

- To protect against electrical shock, do not immerse cord, charger, transformer, battery, or the product in any liquids.
- Only use charging devices, transformer, and battery provided or recommended by the manufacturer.
- For your children's safety, the product should be assembled by adults only.
- This toy is not intended for children under 18 months.
- Close and constant adult supervision is required when your child is operating this product.
- Disconnect the battery if not used for an extended period of time.
- Do not use this product as a traffic tool.
- To reduce the risk of injury, adult supervision is required. Never use in roadways, near motor vehicles, on or near steep inclines or steps, swimming pools or other bodies of water; always wear shoes, and never allow more than 1 rider.
- Do not use this product on slippery surfaces.
- Always keep hands, hair, and clothing away from moving parts.
- Maximum users' weight for this product is 66 lb/30 kg.
- Do not change, modify or add any electrical wiring on this product.
- Avoid using this product in tight environments to prevent damage to the product or injury to the user.
- Do not use this product in the dark. Only operate this product during daytime or well-lit areas.
- For your child's safety, please make sure the seat belt is securely fastened when operating this product.
- Personal protective equipment such as helmet is required when operating this product.



⚠ WARNING

Fire Hazard

- Never modify the electrical system. Alteration could cause a fire resulting in serious injury and could permanently damage the electrical system.
- Use of the wrong type of battery or charger could cause a fire or explosion resulting in serious injury. The battery must be handled by adults only. The battery is heavy and contains sulfuric acid (electrolyte). Dropping the battery could result in serious injury.
- Never allow children to charge the battery. Battery charging must be done by adults only.
- Never lift or carry the battery by the wires or connector. This can damage the battery and possibly cause a fire resulting in serious injury. Lift and carry the battery by the case only.
- Examine the battery, charger, and their connectors for excessive wear or damage each time before you charge the battery. DO NOT use the charger or battery until worn or damaged parts are replaced.

⚠ WARNING

- Avoid continuously hitting into obstacle to prevent overheating or damaging the motor. Drive away or remove obstacle as soon as possible.

⚠ WARNING

- Manufacturer and seller expressly disclaim any and all liability for personal injury, property damage or losses, whether direct, indirect, or incidental, resulting from the incorrect attachment, improper use, inadequate maintenance, unapproved modification, or neglect of this product.

⚠ WARNING: Stop operating this product whenever it stuck under any circumstances.

⚠ WARNING: Friction Hazards! Do not operate this product on carpets or rugs, it may cause burn or fire if over run or over spin. This product has automatic cut-off function if overcurrent, overloaded, or operated incorrectly, wait for 10-15 seconds to reactivate this product automatically.

⚠ WARNING: This toy is to be assembled by an adult. Contains potentially hazardous sharp edges and sharp points, or contains small parts before assembly.

⚠ WARNING: Do not drive this vehicle into any puddle or contact with any liquids to avoid the electrical shock to product or user.

⚠ WARNING

FAILURE TO FOLLOW THE SAFETY INSTRUCTIONS LISTED BELOW MAY RESULT IN SERIOUS INJURY OR DEATH

The owner's manual contains assembly, use and maintenance instructions.

Child Safety Warnings

- Adults supervising children must read and understand this entire manual before allowing any child to use this product.
- Adults must evaluate their own children as to maturity, strength, judgment and ability to follow safety rules. Published age guidelines are not a substitute for careful evaluation of your own child.
- Adults must teach children about thinking ahead while riding as this may be the first time a child has ever controlled a motorized ride-on toy. While you supervise, see through the child's eyes, and verbally teach them about steering and avoiding obstacles in the approved riding area.
- Riding a motorized ride-on toy can be a dangerous activity, even under the best of circumstances. Good choices regarding where and when to ride, constant adult supervision of riding, and practice and careful riding by the child can all help to minimize risk. However this ride-on toy is intended to move and therefore it is possible for the rider to lose control, fall off and/or get into dangerous situations that no amount of care, instruction or expertise can eliminate.
- If this inherent risk is not acceptable, adults should not allow children to ride this ride-on toy.

WARNING

Safe Riding Warnings

- **Not to be used by children under 18 months or children over 72 months.**
- **Do not exceed the maximum weight capacity of 66 lbs(30 kg).**
- **Do not allow more than one (1) rider.**

ADULTS AND SUPERVISORS, PLEASE NOTE:

1. Always instruct all children of common sense rules and safe practices.
2. Be aware that flat, hard surfaces provide the safest experience for child riders.
3. Do not allow the child rider to operate the ride-on toy near streets, roads, sidewalks, walkways, or any other place where they may encounter other moving vehicles.
4. Never leave children unattended with this ride-on toy. Continuous adult supervision is required.
5. If necessary, adults and supervisors are always responsible for setting up gates and barriers to ensure a safe riding environment for the child rider.
6. Be aware that this ride-on toy does not have braking capabilities. Allowing use of this ride-on toy in areas that require braking may cause rolls, crashes, serious injury, or death to the child rider.
7. Teach children not to allow other children to use this ride-on toy. Communicate this message to other adults and supervisors of fellow children with which your child interacts.
8. Sternly alert children that hands, legs, hair, and clothing can potentially get caught in moving parts. Ensure they never place a body part or piece of clothing near a moving part of the ride-on toy. Avoid loose clothing.
9. Instruct children to always wear shoes when using the ride-on toy.
10. Confirm that children do not have access to the charging equipment or come into contact with any part of the ride-on toy while it is charging.
11. Do not mix old and new batteries.
12. Do not mix alkaline, standard (carbon zinc), or rechargeable batteries.
13. Firmly instruct children to use the ride-on toy in a safe manner. Unsafe behaviors include, but are not limited to:
 - Traveling at unsafe speeds
 - Not riding in the seated position
 - Riding at night or in any conditions of low visibility
 - Riding in any wet conditions including rain, snow, and ice
 - Any kind of stunt riding: jumps, ramps, stairs, hills, sloped surfaces, or other actions involving any notable risk
 - Any kind of off-road riding: rough terrain, dirt, mud, gravel, or any others that involve notable risk
 - Riding near any pool or open body of water
 - Pushing, pulling, or shoving the driver in any way while operating the ride-on toy
 - Using the ride-on toy without the battery cover or any other safety cover fully closed
 - Pulling or hitching the ride-on toy with other similar moving ride-on toys or products

WARNING

Battery and Charging Warnings

The following safety hazards may result in serious injury or death to the user of the ride-on:

- Do not mix old and new batteries.
- Do not mix alkaline, standard (carbon-zinc), or rechargeable (nickel-cadmium batteries.)



Corrosive Material Warnings

- Battery posts, terminals and related accessories contain lead and lead compounds (acids) chemicals and are toxic and corrosive. Never open the battery.
- Contact or exposure to battery leakage (lead acid) may cause serious injury. If contact or exposure occurs with the skin or in the eyes, or if the chemical is swallowed, immediately call 911.



Flammable and Explosive Materials Warnings

- Use of a battery or charger other than the supplied rechargeable battery and charger may cause a fire or explosion. Only use the supplied rechargeable battery and charger with the ride-on toy.
- Do not charge the battery near heat or flammable materials.
- Using the rechargeable battery and charger for any other product may result in overheating, fire or explosion. Never use the rechargeable battery and charger with another product.
- Contact between the positive and negative terminals may result in fire or explosion. Avoid direct contact between the terminals. Lifting the battery by the wires or charger can cause damage to the battery and may result in a fire. Always lift the battery by its case or handles.
- Plug wall charger directly into a wall outlet. Do not use an extension cord when charging as the use of an extension cord can cause a fire.



Electric Shock / Fire Warnings

- Liquids on the battery may cause fire or electric shock. Always keep all liquids away from the battery and keep the battery dry.
- Tampering or modifying the electric circuit system may cause a shock, fire or explosion and permanently damage the system. Exposed wiring, circuitry in the charger may cause electric shock. Always keep the charger housing closed.
- Regularly check charger, supply cord and connector for wear and damage. Look for frayed or kinked wires, any exposed inner wires, any missing insulation. If any damage is observed do not plug in the charger and do not charge the battery.

CAUTION

Re-Charge Interval and Time

Important!

- Damage to the battery may occur if it is allowed to drain completely. Do not allow the battery to drain completely.
- Check the battery and charger (supply cord, connector) for wear and damage before charging. Do not charge the battery if damage has occurred. Do not use an extension cord when charging the ride-on toy.
On average you will need to charge the battery for 8 - 12 hours and no more than 20 hours.
- Failure to charge the battery as directed could cause permanent damage to the battery and void the warranty.
- Only an adult who has read and understands the safety warnings should handle, charge and recharge the battery.

WARNING

Product Warning

WARNING

This product can expose you to chemicals including lead, and lead components which is known to the State of California to cause cancer and birth defects or other reproductive harm. For more information go to www.P65Warnings.ca.gov.

Assembly Warnings

- The ride-on toy must be assembled by an adult who has read and understands the instructions in this manual.
- This ride-on toy contains small parts that are for adult assembly only. Keep small children away when assembling.
- Remove and dispose of all protective materials, plastic bags and packaging before assembly.

Product Specification

Motor: 12V 25W*2

Battery: 6V 4.5AH*2

Charger: 12V1000MA

Speed: 1.2~1.9mph(2~3km/h)

Suitable Age: 18 -72 months

Maximum User Weight: 66 lb / 30 kg

Dimension: 31.50" x 21.26" x 15.75" (800 x 540 x 400 mm)

Battery Charge Time: 8 - 12 hours

First charging time: 10~12 hours

Max charging time: 20 hours

Battery (Temperature Tolerance) : -15°C (-5°F) TO 60°C (140°F)

Operation Time: 1~2 hours

Parts and Feature



① Vehicle Body



② Steering Wheel

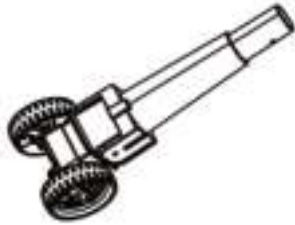

③ Steerable Front Wheel



④ Backrest



⑤ Seat



⑥ Charger



⑦ Remote Control



⑧ M5 x 39 Screw



⑨ M4 x 10 Tapping Screw



⑩ M5 Nut

Assembly Instruction

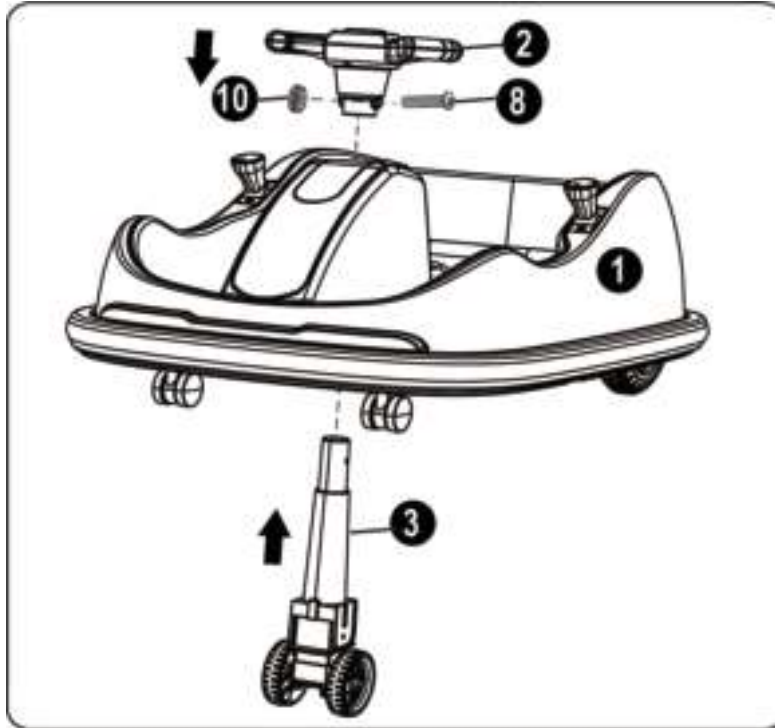

- Lift up the ① Vehicle Body and insert the ③ Steerable Front Wheel through the opening.
- Unscrew the ⑧ M5*39 Screw and ⑩ M5 Nut from ② Steering Wheel.
- Align and insert the ② Steering Wheel to the front wheel column. Using ⑧ M5*38 Screw and ⑩ M5 Nut to fix the steering wheel on the top of the steerable front wheel column.

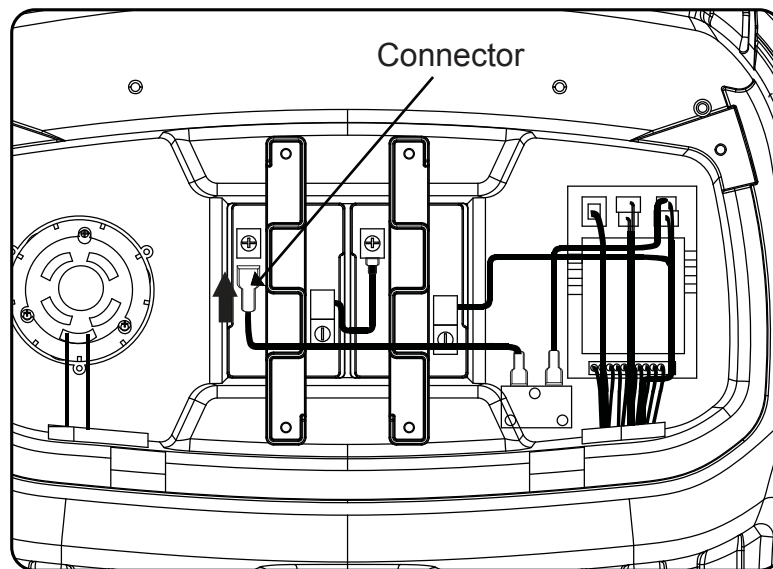

- Power supply is located under the seat location. Plug the connector to the terminal on the battery.

Assembly Instruction

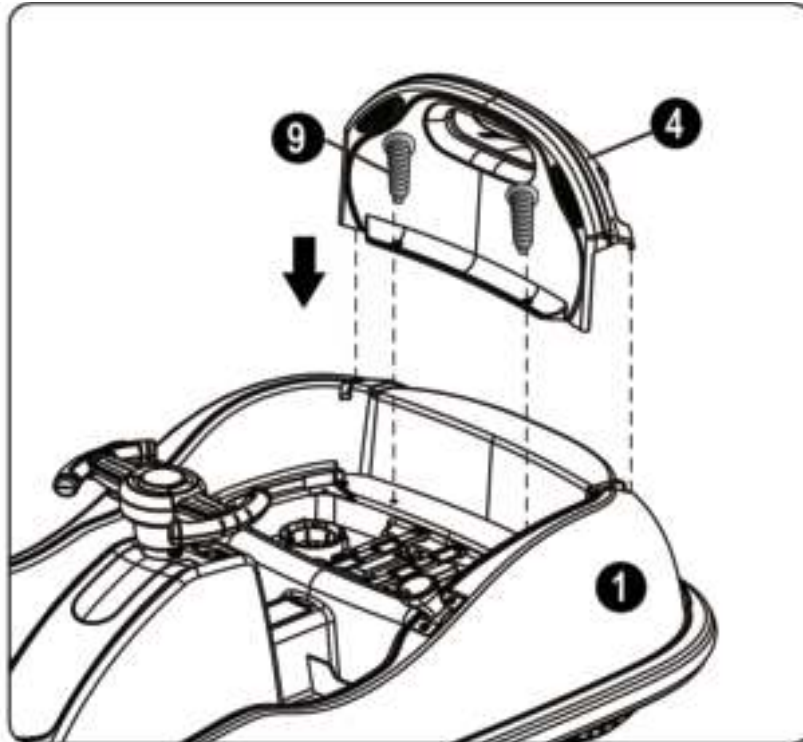

- Unscrew the attached 4 pcs ⑨ M4 x 10 Tapping Screws.
- Insert the ④ Backrest to the ① Vehicle Body and secure by using two ⑨ M4 x 10 Tapping Screws .

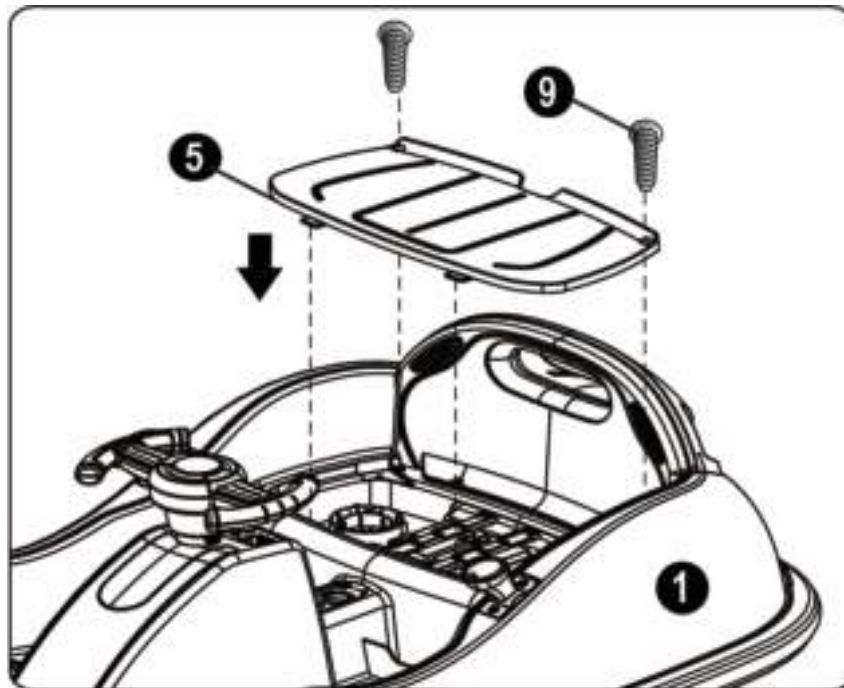

- Put on the ⑤ Seat and secure by using two ⑨ M4 x 10 Tapping Screws .

User Instruction

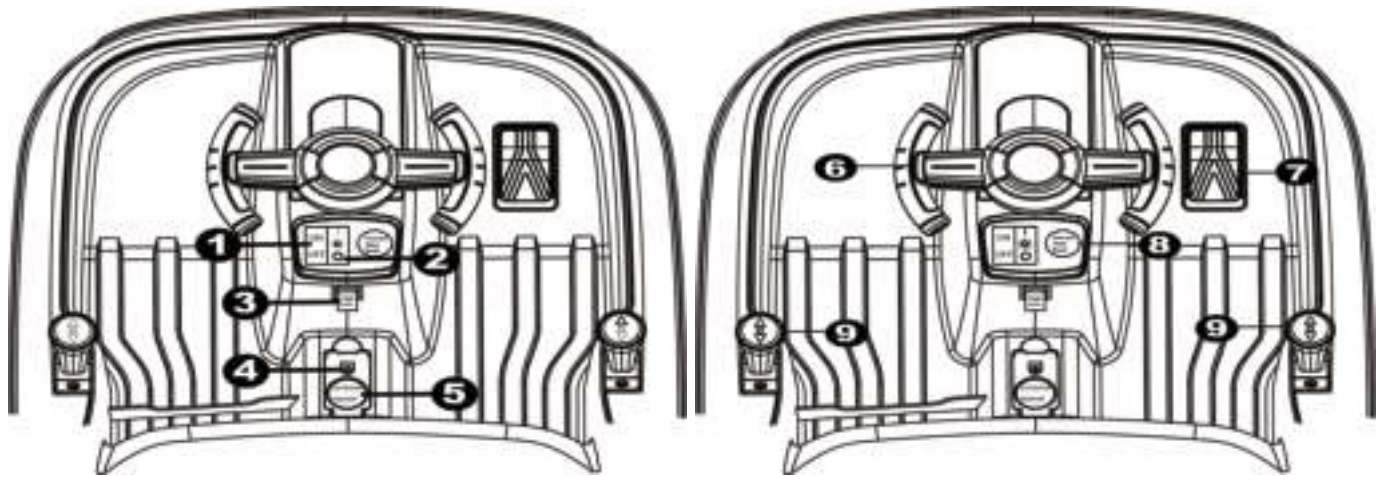

Control the vehicle

1. Start Switch

Turn the product on and off .

2. Light Switch

Turn on and off the light.

3. High-Low Speed Switch

Press to switch between high and low speed.

4. Charging Slot

Plug the charger in to charge battery.

5. Indoor / Outdoor Switch

Switch between indoor and outdoor mode.

6. Steering Wheel

Steer the vehicle left and right.
Only operate in outdoor mode.

7. Foot Pedal

Step on the pedal to move the vehicle.
Only operate in outdoor mode.

8. Forward / Reverse / Stop Switch

Press the switch to enable

⚠ Do not change the speed or direction until the vehicle comes to a complete stop.

9. Control Stick

Move and turn the vehicle by pushing or pulling the control stick.
Only operate in indoor mode.

Bluetooth connection

To connect your mobile device to the vehicle, turn on the Bluetooth and select "KIDZONE BUMPER CAR", there is voice message after pairing successfully. Music can be played from the vehicle speaker according to the user preferences.

To disconnect your mobile device to the vehicle speakers, turn off the Bluetooth.

User Instruction

Indoor Mode:

When using the vehicle indoor, switch the setting to indoor mode.

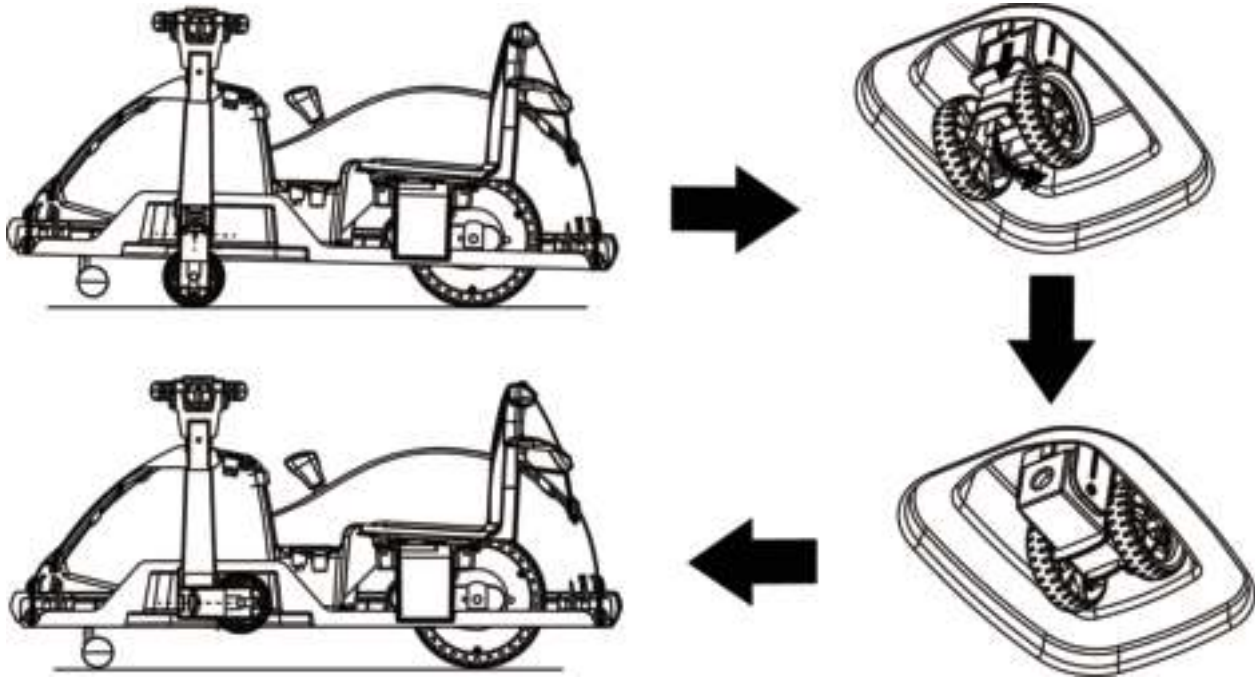

- Lift up the vehicle body.
- Press the plastic buckle and fold up the steerable front wheel into the body.

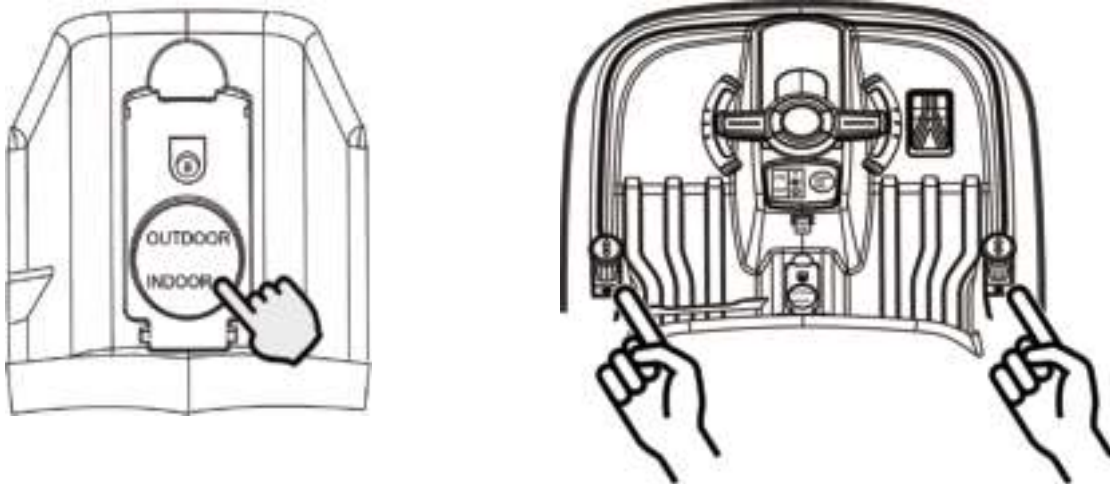

- Press the switch to indoor mode.
- Control the vehicle using the control stick on the side on the vehicle.
NOTE: Control sticks can only be operated in indoor mode.
- Remote control can only be operated in indoor mode.



Operating this vehicle by using control stick:

To move the vehicle forward, push both control sticks forward at the same time.

To move the vehicle backward, pull both control sticks backward at the same time.

To left turn the vehicle forward, push the right control stick forward.

To right turn the vehicle forward, push the left control stick forward.

To left turn the vehicle backward, pull the right control stick backward.

To right turn the vehicle backward, pull the left control stick backward.

To left spin the vehicle, pull the left control stick backward and push the right control stick forward at the same time.

To right spin the vehicle, push the left control stick forward and pull the right control stick backward at the same time.

To stop the vehicle, release both control sticks and returns them to the center position.

User Instruction

Outdoor Mode:

When using the vehicle outdoor, switch the setting to outdoor mode.

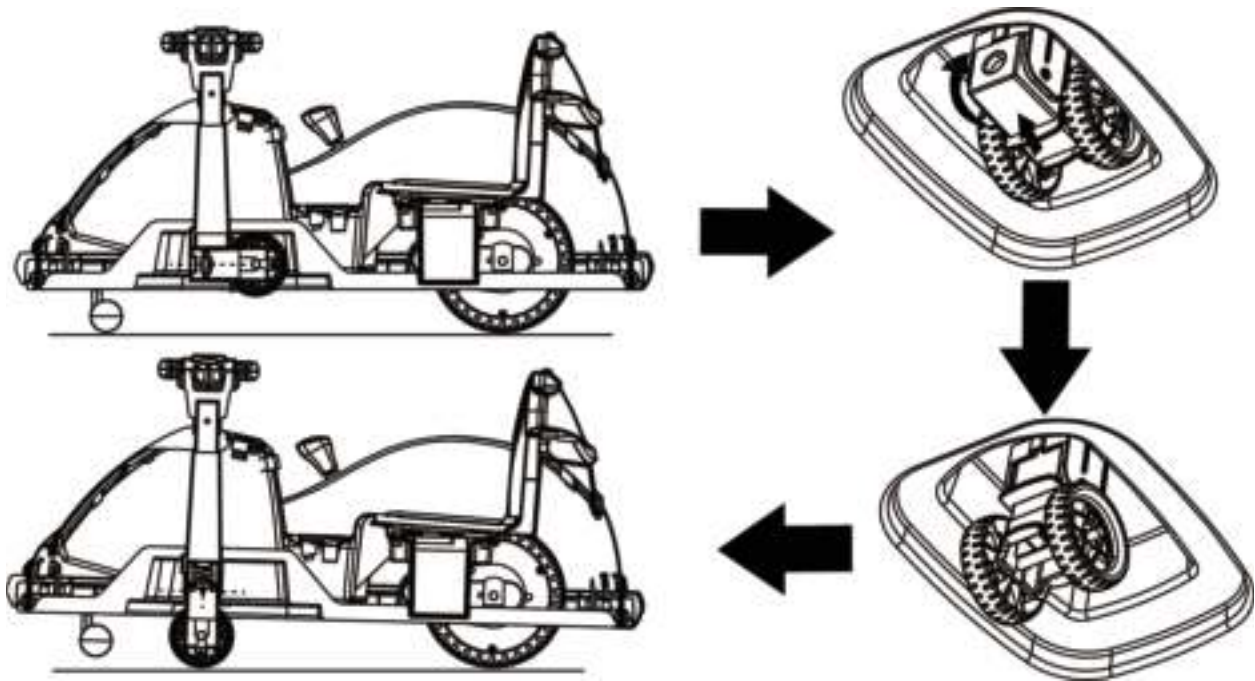

- Lift up the vehicle body.
- Press the plastic buckle and fold down the steerable front wheel.

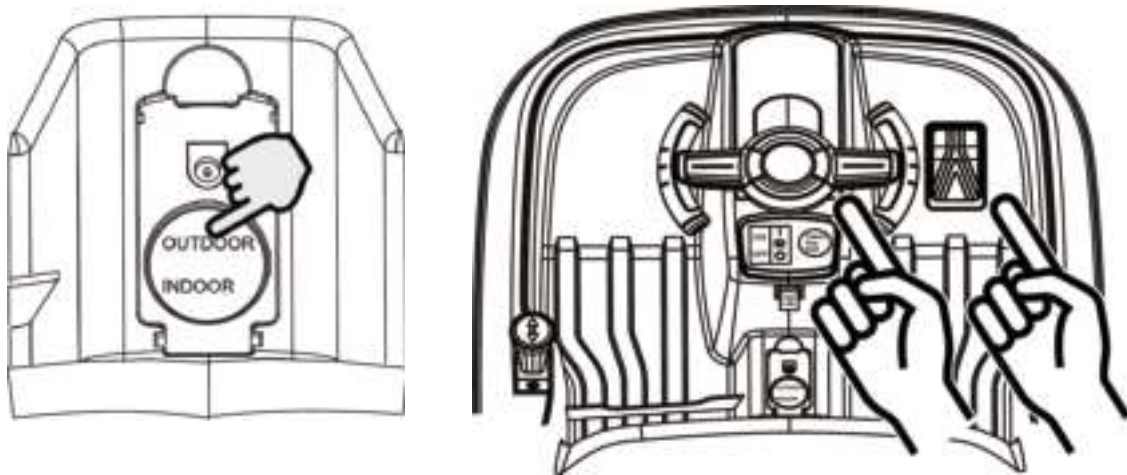

- Press the switch to outdoor mode.
- Control the vehicle using the steering wheel and foot pedal.
NOTE: Remote control can only be operated in indoor mode.

- Do not use the remote control in outdoor mode to prevent damaging the vehicle.



User Instruction (Remote Control)

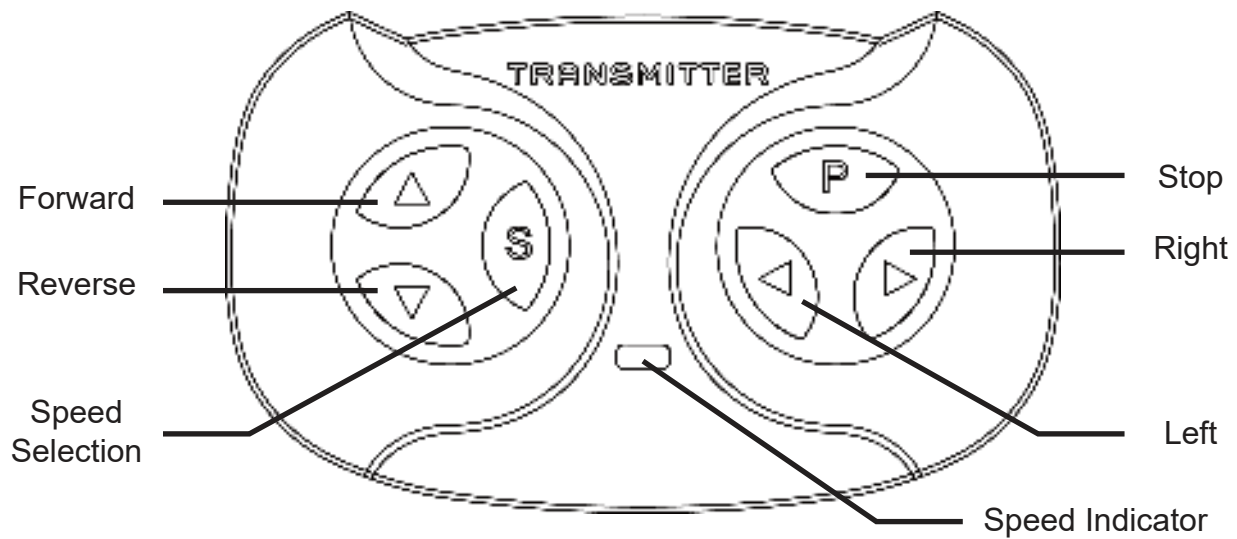

Remote Control Buttons

1. Forward Button

Press to move the vehicle forward.

2. Reverse Button

Press to move the vehicle backward.

3. Speed Selection Button

Press to switch between low, medium, or high speed.

4. Stop Button

Press to stop the vehicle.

5. Right Button

Press to turn the vehicle to the right.

6. Left Button

Press to turn the vehicle to the Left.

7. Speed Indicator

One light indicates in low speed.

Two lights indicate in medium speed

Three lights indicate in high speed.

User Instruction (Remote Control)

Using the remote control

The remote control should only be used by adult.

ATTENTION:

The remote control will override all control input from the vehicle control sticks.

The remote control should only be used when the vehicle is in indoor mode.

Insert / Changing Battery

1. Open the battery cover on the back side of the remote control.
2. Insert 2 AAA 1.5v cell batteries in the correct polarity
3. Put the cover back to the remote control.

NOTE: Do not mix old and new batteries. Do not mix alkaline, standard (carbon-zinc), or rechargeable batteries.

WARNING!

The battery should only be changed by an adult.

Pairing the remote control to the vehicle

1. Press Forward and Reverse button simultaneously until the indicator light flashes.
2. Turn on the vehicle power.
3. The indicator light will stay on when the pairing is succeed.

User Instruction (Charging)

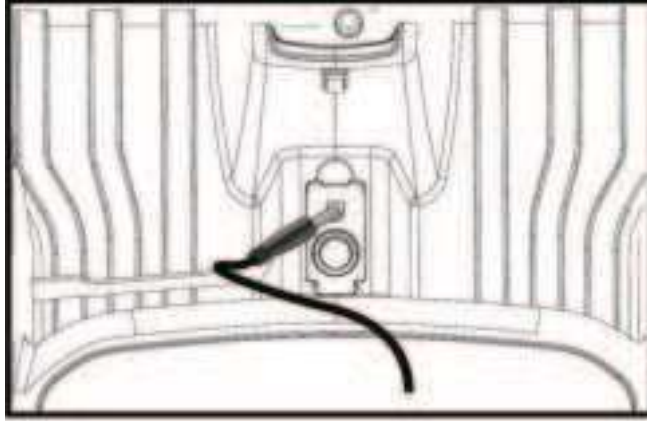

⚠ WARNING!

The battery should only be charged by an adult. The battery is not replaceable.

Charging the battery

1. Insert the charging cable to the charging port located in front of the indoor / outdoor switch.
 2. Insert the charger plug into a wall outlet, and the battery will start charging.
 3. The charger indicator turns red when charging, turns green after charging completed.
- The vehicle must be OFF when charging.
 - Recharge the battery if the vehicle operates slowly.
 - The vehicle has equipped with charging protection. All function of the vehicle will not be operated when charging.

NOTE:

Damage to the battery may occur if it is completely drained.

Fully charge the battery for 8 - 12 hours, do not charge the battery for more than 20 hours.

Charge the battery at least once a month even if not operating the vehicle to maximize the battery life.

Care and Maintenance

- Check the product regularly and make sure there is no missing or loose parts. Re-tighten any loose parts if necessary.
- Make sure there is no cracked or broken plastic parts.
- Keep away the product from heat and humid area, cover it with trap when not in use.
- Turn off the product and disconnect the battery if the product is not use for a long period of time.
- Clean the vehicle with a cloth. Use a non-wax furniture polish to restore the shininess of the plastic parts. Do not use abrasive cleaner.
- Do not wash the product with a hose or immerse any parts in water or other liquid.
- Occasionally use lightweight oil to lubricate moving parts

Troubleshooting

Problem	Possible Reason	Solution
Vehicle does not move	Low Battery	Fully charge the battery
	Fuse Protection	Reset fuse
	Disconnected / Badly connected battery	Reconnect the battery
	Failed battery / engine	Contact Customer Service
Vehicle does not run very long	Low Battery	Fully charge the battery
	Old Battery	Replace battery if necessary
Vehicle runs very slow	Low Battery	Fully charge the battery
	Old Battery	Replace battery if necessary
	Vehicle is overloaded	Make sure user's weight is under 66 lb / 30 kg
	Vehicle is being used in harsh environment	Avoid using the vehicle in harsh environment

Troubleshooting

Problem	Possible Reason	Solution
Vehicle needs a push to go forward	Poor wire connection	Check if the battery connectors are firmly connected. Contact Customer service if necessary
	"Dead spot" on motor	Contact customer service
Loud grinding sound or clicking sound from the motor or gear box	Damaged motor or gear box	Contact customer service
Battery does not charge	Disconnected / Badly connected battery	Reconnect the battery
	Disconnected / Badly connected charger	Make sure the charger is firmly plugged into the power source and connected to the charging port
	Charger not working	Contact customer service
Vehicle does not stop	Damaged equipment	Contact customer service
Charger becomes warm during charging	Normal	N/A

Model: JR1602FCC

FCC ID: 2AWOBJR1602

This device complies with part 15 of the FCC Rules. Operation is subject to the following two conditions:
(1) this device may not cause harmful interference, and
(2) this device must accept any interference received, including interference that may cause undesired operation.

NOTE: This equipment has been tested and found to comply with the limits for Class B digital device, pursuant to part 15 of the FCC rules. These limits are designed to provide reasonable protection against harmful interference in a residential installation. This equipment generates, uses and can radiate radiofrequency energy and if not installed and used in accordance with the instructions, may cause harmful interference to radio or television reception, which can be determined by turning the equipment off and on, the user is encouraged to try to correct the interference by one or more of the following measures:

- Reorient or relocate the receiving antenna.
- Increase the separation between the equipment and the receiver.
- Connect the equipment into an outlet on a circuit different from that to which the receiver is connected.
- Consult the dealer or an experienced radio/TV technical for help.

Caution: Changes or modifications not expressly approved by the party responsible for compliance could void the user's authority to operate the equipment.

This product conforms to toy safety standards CPSIA and ASTM-F963.

Importer: ONE BIG OUTLET

Importer Address: 19301 E Walnut dr. N. City of industry CA91748 united states

Importer Tel.: 800 - 946 - 6151

Limited Term Warranty (One Year from Date of Purchase)

WARRANTY TERMS

KIDZONE warrants that its merchandise are free from manufacturing defects (workmanship and/or material) and will either give credit or replace defective parts for a period of up to one (1) year from the date of purchase in accordance with the conditions set forth below. If a manufacturing defect is found, KIDZONE should be notified promptly of the defect and supplied a copy of the invoice and delivery ticket. Inspection by a KIDZONE employee or representative may be necessary to verify that a manufacturing defect exists, or you may be required to submit samples to KIDZONE along with a digital image of the defects. If replacement is required in accordance with this warranty and the defective material or merchandise has been discontinued or unavailable, KIDZONE reserves the right to select and supply similar merchandise or offer full credit for the merchandise; otherwise the same material or merchandise will be supplied for replacement purposes. This warranty is made solely to the retailer and is not transferable under any circumstances. It is the retailer's responsibility to contact KIDZONE with a claim. We will not handle claims from consumers directly; all requests must go through the retailer who sold the merchandise to the consumer. We advise all retailers to retain invoices for a minimum of one (1) year for warranty purposes. This warranty supersedes and replaces all implied warranties of merchantability and use for particular purpose. No representative, employee, agent or any other person is authorized to assume for KIDZONE any additional liability or responsibility in connection with KIDZONE's merchandise except as described above. Implied warranties or merchantability and fitness of the merchandise are limited to a period of one (1) year from the date of purchase. In no event shall KIDZONE be liable for indirect, consequential or incidental damages of any kind.

ADDITIONAL CONDITIONS

THE FOLLOWING EXAMPLES ARE NOT MANUFACTURER'S DEFECTS:

- Colors may vary slightly from the photo because of photography and printing tolerances.
- Sizes stated in U.S. standard measurements may vary slightly due to product are manufactured using the metric system.
- No returns for buyer's remorse.
- No returns - other than stated above will be accepted.

ADDITIONAL CONDITIONS

WARRANT IS VOID FOR ANY OF THE FOLLOWING CONDITIONS:

1. Improper maintenance or improper use resulting in damage.
2. Any product modifications by dealer, consumer, or other parties not authorized by KIDZONE will void this warranty.
3. Floor samples sold or products designated "AS IS" at the time of purchase are not covered by the warranty
4. Warranty does not cover minor variations or differences between floor samples or printed illustrations and your product.
5. Cost of packaging and shipping to and from KIDZONE is not covered by the warranty unless expressly arranged by KIDZONE.
6. This warranty covers only articles of appliances intended for residential use only, does not cover any industrial, commercial, institutional or Rental use.
7. Dissatisfaction due to buyer's remorse.
8. Normal wear and tear.
9. Damages incurred during transportation.
10. Damages incurred during assembling or maintenance.
11. Damage incurred by accidents or abuse.

V1-2021-08-12