

KL18210

Instruction Manual

KegLand Distribution PTY LTD

www.KegLand.com.au



ENSURE THAT THERE IS ALWAYS ATLEAST 100mm OF CLEARANCE ON EACH SIDE OF THE BENCHY TO ALLOW ADEQUATE AIRFLOW.



AVOID EXTERNAL HEAT SOURCES SUCH AS DIRECT SUNLIGHT, GAS STOVES OR OTHER HEAT GENERATING APPLIANCES.



ONLY USE KEGLAND APPROVED CLEANERS AND SANITISERS TO CLEAN THE PRODUCT LINES.



DO NOT SET THE TEMPERATURE BELOW 0°C OR YOU RISK FREEZING THE BEVERAGE YOU ARE DISPENSING.



ONLY USE ON A FLAT SURFACE OR AT A MAXIMUM ANGLE OF 20 DEGREES OFF LEVEL



WARNING

NEVER USE A BATTERY CHARGER, TRANSFORMER/RECTIFIER, BATTERY ELIMINATOR OR AC/DC CONVERTER TO POWER THE PRODUCT UNLESS SUPPLIED BY KEGLAND

SETTING THE TEMPERATURE (ESC-961neo)

1. Press and release the “set” to enter into the user menu.
2. Press “set” will display the value of the target temperature setting.
3. Press the up and down arrow to adjust the value of the set temperature.
4. Press  button or wait 30 seconds and the setting will be saved and return back to the home screen

WARNING: Do not set the temperature below 0°C or you risk freezing the beer or beverage that you are dispensing. For a more detailed instruction manual for the controller download this from the keglan website or go to the link below.

[ESC-961neo temperature controller user manual](#)

INSTALLATION REQUIREMENTS

ONLY USE ON FLAT SURFACE

The Benchy Carbon should only be used on a flat surface or at a maximum angle of 20 degrees off level. **DO NOT** operate this unit on its side or at angles greater than 20 degrees or permanent damage to the compressor will occur

PROVIDE ADEQUATE VENTILATION AND AVOID EXTERNAL HEAT SOURCES

In order to achieve the best possible performance from the Benchy Carbon we recommend 100mm clearance around air vents. External heat sources such as direct sunlight, gas stoves or other heat generating appliances should be avoided.

DO NOT USE BATTERY CHARGERS OR DC GENERATORS

Never use a battery charger, transformer/rectifier, battery eliminator or AC/DC converter to power the product (unless supplied by KegLand). Such equipment can, under certain circumstances, delivery current at a voltage which may damage the inverter. In order to use these devices always ensure that a battery is connected in parallel between the charging equipment and the product

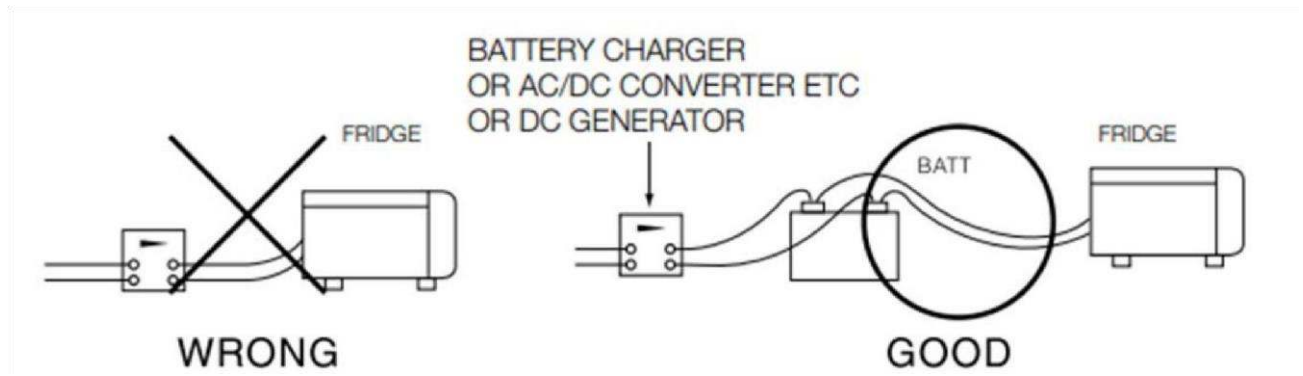

DC CABLE REQUIREMENTS

DC cable gauge and length requirements

DC power systems have significantly higher losses over cable and this can be exacerbated by insufficient cable or bad cable joins. When running the Benchy Carbon off battery power it's important to understand that longer cable requires thicker cable to avoid excessive power loss. We recommend pure copper cable (not aluminium or copper plated). The table below shows the necessary minimum gauge required. It's ok to use smaller cable but do not use larger cable than this.

AW Gauge	Cross section (mm ²)	Max Length 12V DC (feet)	Max Length 12V DC (meters)	Max Length 24V DC (feet)	Max Length 24V DC (meters)
13	2.5	8	2.5	16	5
12	4	13	4	26	8
10	6	20	6	39	12
8	10	33	10	66	20

DC Voltage requirements

The voltages in the table below specify the voltage required to the compressor. This does not take into account voltage loss in fittings such as cigarette lighter sockets, cable joins or the cable itself that you might have in your system. For best performance use quality fittings, thick cable and firm fitting Anderson sockets to ensure your DC cabling losses are kept to a minimum.

DC power systems can operate between 9.6V DC and up to 18V DC or alternatively from 21.3V DC and up to 31.5V DC.

NOTE: If you would like to run this unit on DC Voltages between 18V and 21.3V you will need to purchase a step down power module (DC to DC converter). This can be handy if you want to run the Benchy Carbon off commonly available 18V Drill Batteries.

12V Cut-Out	12V Cut-In	12V-Max	24V Cut-Out	24V Cut-In	24V-Max
9.6V	10.9V	18.00V	21.3V	22.7V	31.5V



DISPENSING FROM THE BENCHY GLYCOL

Before attaching the Benchy Carbon to your keg first screw your taps onto the two shanks on the front of the Benchy and tighten the shank collar using a 7 in 1 Facet Tap Wrench/Spanner Tool.

After tightening your taps onto the shanks, you can then plumb your kegs in to the Benchy Carbon. On the back of the Benchy you will find two 8mm push in bulkhead fittings. Simply push 8mm OD EVABarrier tubing from your liquid ball lock disconnect or keg coupler into the bulkhead fitting. Then attach the ball lock disconnect or keg coupler onto your liquid keg post or spear respectively.

Ensure that the EVABarrier hose is cut straight and cleanly with a Stanley knife or 2 in 1 tube cutter ([KL07689](#)). Then firmly push the EVABarrier hose into the opening of the bulkhead. Make sure that the hose is pushed in to its full depth. Then check for a good connection by gently pulling back on the hose. If the hose comes out of the push in fitting, reinsert ensuring the hosing is pushed far enough into the fitting.

To remove EVABarrier hose from the push in fitting, simultaneously push the collet in while pulling the EVABarrier hose out of the push in fitting. Once the hose is removed cut the burred end off with a 2 in 1 tube cutter or Stanley knife to produce a clean straight cut.

A 7 in 1 spanner tool ([KL07672](#)) can also be used to remove hosing from the push in fitting. Insert the hose into the groove in the centre of the spanner and use the spanner to press in on the collet while pulling on the hose.

After your taps are attached and your kegs are plumbed into your Benchy Carbon you can then hook CO2 up to your keg and set the pressure based on your desired carbonation level and the ambient temperature according to a carbonation chart.

[KegLand Carbonation Chart](#)

Further tips on [how to balance your Benchy dispensing system with CO2](#) are described later in this instruction manual

Benchy – Carbon 12V/24V Instruction Manual

Benchy Carbon – Dispensing from Cornelius Ball Lock Kegs



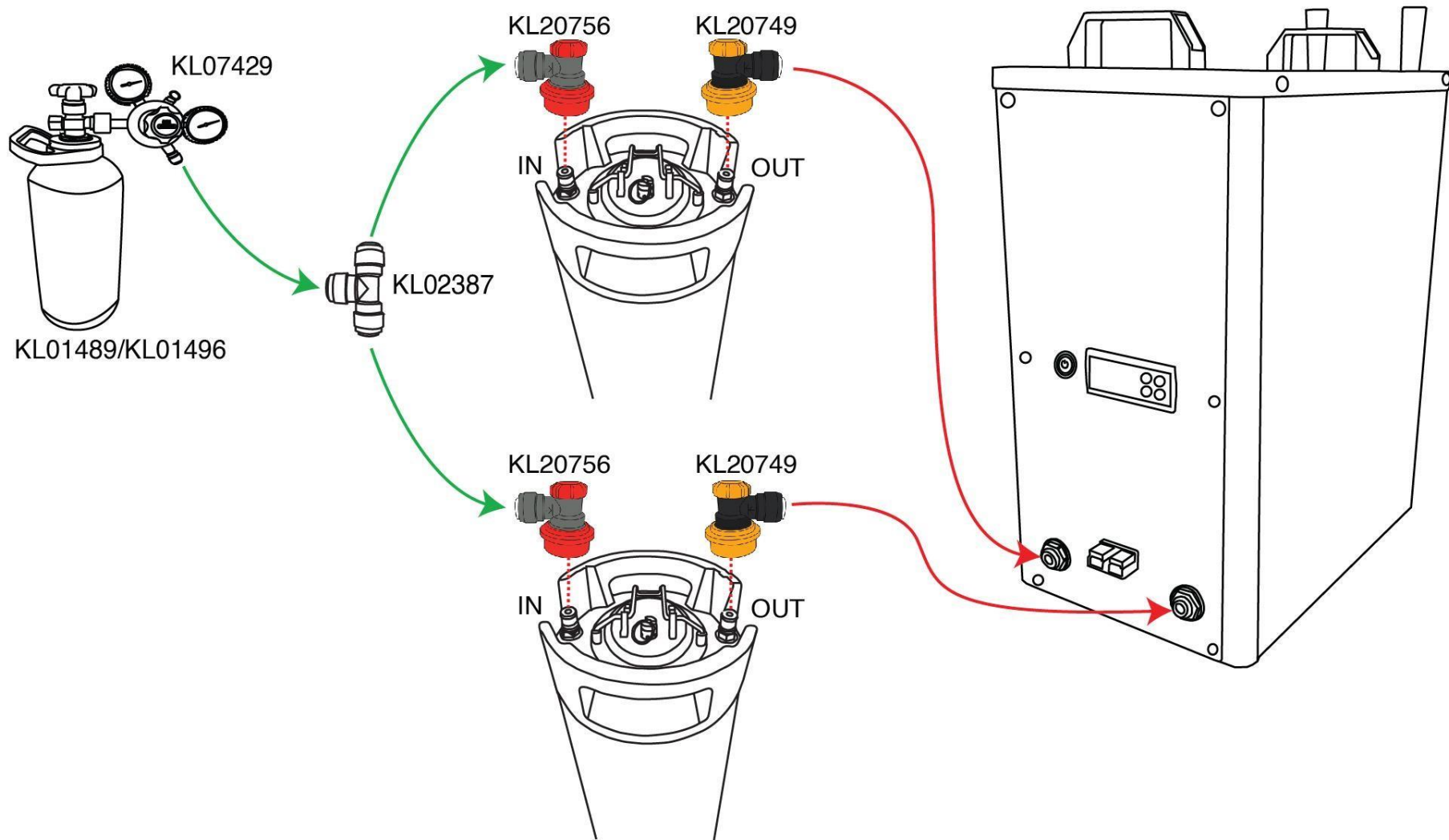

Benchy Carbon – Dispensing from Commercial Kegs

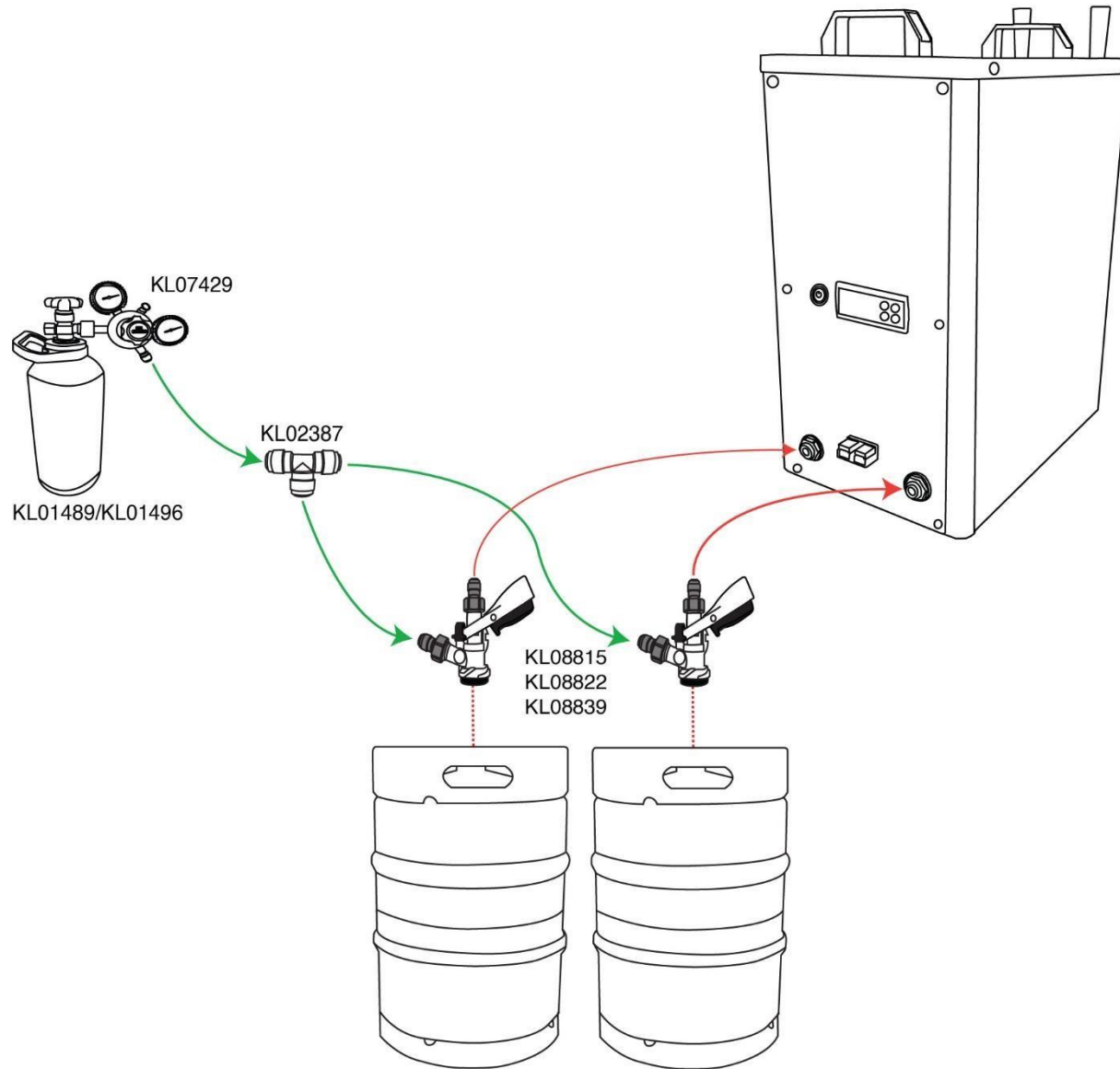



Balancing Your Benchy Dispensing System with CO₂

The pressure to be set on your regulator differs according to the temperature that the keg is stored at. If the product is stored at a higher temperature it will require a higher pressure to maintain the desired level of carbonation. Refer to a carbonation chart to determine what pressure you should be setting your regulator at to reach your desired level of carbonation based on the ambient temperature the keg is stored in.

For most styles of beer, you should be aiming for a carbonation level of between 2.3-2.8 volumes of carbonation with the average carbonation level being 2.6 volumes (if you are unsure of the carbonation level of the beer i.e. if it is a commercial keg then assume it is at 2.6 volumes of carbonation). To achieve a specific carbonation level during carbonation or priming refer to the table in the link below and correlate the temperature of the keg with the desired carbonation level.

[KegLand Carbonation Chart](#)

NOTE: Do not try to fix a slow or fast pour rate by adjusting the dispensing pressure. This will result in your beer either going flat or over carbonated. It is best to adjust the beverage line length and diameter. If the pour is too fast and is producing a lot of froth then increase the length of the beverage line between the Benchy and the keg. Alternatively, if the pour is too slow then decrease the length of the beverage line between the Benchy and the keg.

When adjusting your beverage line length to achieve the perfect pour it is always best to start with a longer length of beverage line as you can always trim a longer length of hose.

CLEANING/MAINTENANCE

Only use KegLand approved cleaners such as [StellarOxy](#) and [StellarClean](#) and sanitisers such as [Phosphoric acid](#) and [StellarSan](#) to clean and sanitise your product lines.

An easy way to clean your product lines with a gas source is to use a Gas Free Ball Lock Line Cleaning Kit. Simply fill a PET bottle with correctly diluted Stellarclean or Stellaroxy solution. Hook up your liquid ball lock disconnect on your product line to the carbonation cap, pump the line cleaning kit

and open your tap to clean your tap and product line. Then rinse with water and repeat with correctly diluted Stellarsan solution.

Use [Homebright streak free stainless steel cleaner](#) and polish spray to clean the outside of the Benchy Carbon to leave it looking shiny and new.



Benchy – Glycol Instruction Manual

FAULT CODES

The power button is a multi-purpose button both turning on the main power to the compressor but also the illumination on the button will flash to indicate fault codes if an error has been triggered.

Number of Flashes	Fault Type
1	Voltage Fault (The input voltage is beyond the setting range)
2	Fan Fault Current (The fan's output current is more than 1A peak)
3	Compressor Start Fault (The rotor is blocked or the system pressure is too high (above 6 bar))
4	Minimum Motor Speed Fault (If the compressor is too highly loaded and cannot maintain minimum rotor speed this will be triggered, also if the controller cannot sense rotor speed this will also trigger this fault code)

5	Thermal Fault of Electronic Unit (If the load on the compressor is too high or if the ambient temperature is too high the controller will not run until it cools down)
6	Controller Hardware Fault (Controller detects abnormal parameters)

WARRANTY AND SUPPORT (AUSTRALIA)

The Benchy Carbon comes with a 12-month warranty when sold in Australia.

To lodge a warranty claim in Australia please forward as many visual pieces of supporting information and a detailed description of your issue to beer@kegland.com.au

If you purchased your unit from a distributor in Australia or internationally, you will be required to go through their warranty claims process.

For a full terms and conditions, please visit our website here -> [Terms & Conditions](#)

For technical support with the Label Applicator Machine please email beer@kegland.com.au

