



# FLOORMATE<sup>®</sup> STEAMSCRUB™ 2-IN-1



WH20440  
Series

**User manual.**

**IMPORTANT: Read carefully before assembly and use.**

# Welcome to Hoover<sup>®</sup> ownership.

**Now you can make it official.**

Visit [www.hoover.com/filter-reminders](http://www.hoover.com/filter-reminders) to receive free service reminders sent straight to your inbox.

Get cleaning confidence for up to 1 full year with the Hoover<sup>®</sup> limited warranty.

## Your Guide:

Safety Instructions	<b>1</b>
Getting started with your steam mop	<b>3</b>
How to use	<b>6</b>
Using your machine	<b>10</b>
Handheld steamer	<b>16</b>
Maintenance	<b>21</b>
Need Help?	<b>26</b>
Troubleshooting	<b>27</b>
Service & Warranty	<b>28</b>

## IMPORTANT SAFETY INSTRUCTIONS

### SAVE THESE INSTRUCTIONS

When using an electrical steam cleaner, basic precautions should always be followed, including the following:

**READ ALL INSTRUCTIONS BEFORE USING THIS STEAM CLEANER. THIS PRODUCT IS INTENDED FOR HOUSEHOLD USE ONLY. IF USED COMMERCIALY WARRANTY IS VOID.**

### **WARNING:** TO REDUCE THE RISK OF FIRE, ELECTRIC SHOCK OR INJURY:

- Fully assemble before operating.
- Operate steam cleaner only at voltage specified on data label on back of steam cleaner.
- Do not leave steam cleaner when plugged in. Unplug from outlet when not in use and before cleaning or servicing.
- Do not use outdoors or store outdoors.
- Do not use for space heating purposes.
- Do not immerse in water.
- Do not allow to be used as a toy. Not intended for use by children age 12 and under. Close supervision is necessary when used near children. To avoid injury, burn, or damage, keep children away from product, and do not allow children to touch steam cleaner while in use or before completely cool, or to place fingers or other objects into any openings.
- Do not use any extension cord with this product.
- Do not handle the plug, or the Steam Mop with wet hands. Do not operate the Steam Mop without footwear.
- Do not place hands or feet under the Steam Mop while it is in operation as the steam cleaner gets very hot and may create a burn hazard.
- Use only on flat, horizontal surfaces. Do not use the Steam Mop on walls, counter tops or windows.
- To protect against a risk of electric shock, do not immerse the Steam Mop into water or any other liquids.
- Use only as described in this manual. Use only manufacturer's recommended attachments and products.
- Do not use with damaged cord or plug. If appliance is not working as it should, has been dropped, damaged, left outdoors, or dropped into water, call Customer Service at 1-800-944-9200 for instructions before continuing use.
- Do not pull or carry by cord, use cord as a handle, close a door on cord, or pull cord around sharp edges or corners. Do not place product on cord. Do not run steam cleaner over cord. Keep cord away from heated surfaces.
- Do not unplug by pulling on cord. To unplug, grasp the plug, not the cord.
- Do not put any object into openings. Do not use with any opening blocked.
- Keep hair, loose clothing, fingers, and all parts of body away from openings.
- Turn off all controls before unplugging.
- Use extra care when cleaning on stairs. When not in use do not place steam cleaner on stairs or furniture, as it may result in injury or damage.
- To avoid burn or injury, do not apply steam directly to any person or animal.

- Only use water to refill the water tank. Do not use any type of chemicals or additives in the water tank.
- Do not add descaling, aromatic, alcoholic products, cleaning solutions, scented perfumes, oils or any other chemicals to the water used in this steam cleaner as this may damage the steam cleaner or make it unsafe for use. While this Steam Mop is designed for tap water, to increase effectiveness of the steam and to avoid build up of minerals, you may use distilled water to fill Steam Mop.
- Do not use Steam Mop in an enclosed space filled with vapor given off by oil-based paint, paint thinners, some moth proofing substances, flammable dust, or other explosive or toxic vapors.
- When in use, never turn the steam cleaner over or use while on its side.
- Allow Steam Mop sufficient time to cool prior to removing the microfiber pad.
- Before cleaning the Steam Mop, unplug the power cord from the electrical outlet and clean with a dry or damp cloth. Do not pour water or use alcohol, benzene or paint thinner on the steam cleaner.
- Do not use in areas where flammable or combustible liquids, such as gasoline may be present.
- Do not use without microfiber pad properly attached to mophead.
- Do not clean over floor electrical outlets.
- Do not use the Steam Mop on leather, wax polished furniture or floors, synthetic fabrics, velvet or other delicate, steam sensitive materials.

- Use only Hoover 4X Steam Multi-Floor Cleaning Solution.
- Do not operate Steam Mop without water in water tank.
- Unplug Steam mop from outlet before filling, rinsing or cleaning. Do not fill water reservoir with more than recommended amount of water. Do not fill detergent reservoir with more than recommended amount of detergent and water.

**WARNING:** This product contains chemicals known to the State of California to cause cancer, birth defects or reproductive harm. **WASH HANDS AFTER HANDLING.**

**CAUTION: TO REDUCE THE RISK OF DAMAGE:**

- Check and follow flooring manufacturers warranty and recommendations regarding the use of steam mops **PRIOR** to using this product on your floors and carpets.
- Store appropriately indoors in a dry place. Do not expose machine to freezing temperatures.
- Never use Steam Mop without microfiber pad attached.
- Never leave Steam Mop in one spot or on any surface for any period of time when pump is turned on and steam is activated.

**WARNING:**

**TO REDUCE THE RISK OF ELECTRIC SHOCK, THIS APPLIANCE HAS A POLARIZED PLUG (ONE BLADE IS WIDER THAN THE OTHER). THIS PLUG WILL FIT IN A POLARIZED OUTLET ONLY ONE WAY. IF THE PLUG DOES NOT FIT FULLY IN THE OUTLET, REVERSE THE PLUG. IF IT STILL DOES NOT FIT, CONTACT A QUALIFIED ELECTRICIAN TO INSTALL THE PROPER OUTLET. DO NOT CHANGE THE PLUG IN ANY WAY.**

# Getting started with your steam mop:

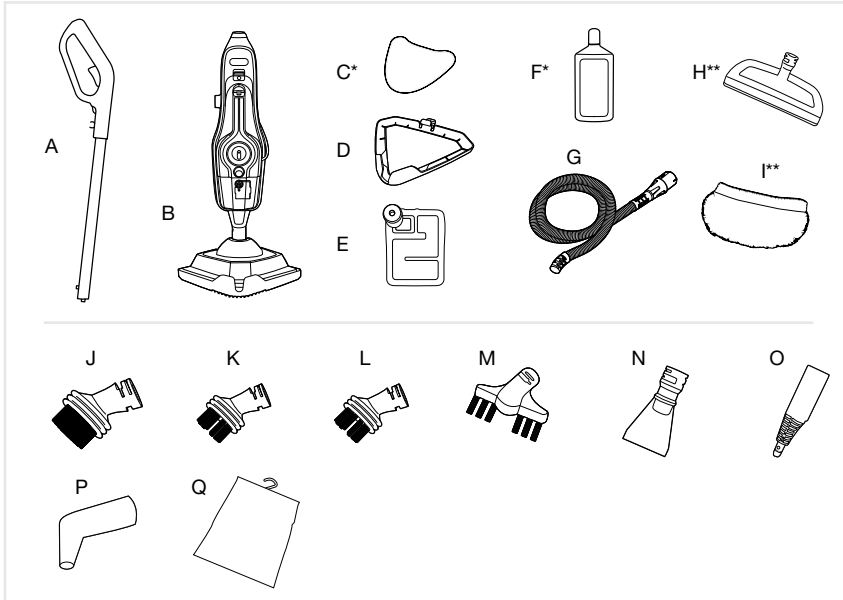

## CARTON CONTENTS

- A. Handle
- B. Steam Mop Body (Water Tank and Solution Tank attached)
- C. Multi-Surface Microfiber Pads (x2) \*quantities vary per model
- D. Carpet Glider
- E. Water Filter (Pre-assembled in steam cleaner, remove water tank to expose filter)
- F. 8 oz. 4X Steam Multi-floor Cleaning Solution \*quantities vary per model
- G. Hose
- H. Squeegee Tool\*\*
- I. Upholstery Cloth Tool\*\*
- J. Large Plastic Brush
- K. Small Plastic Brush
- L. Metal Brush
- M. Grout Brush
- N. Scraper Nozzle
- O. Concentration Nozzle
- P. Detail Nozzle
- Q. Accessory Bag

Remove all parts from carton and identify each item shown.

Make sure all parts are located before disposing of packing materials.

\*\*Select models only

## Assembly:

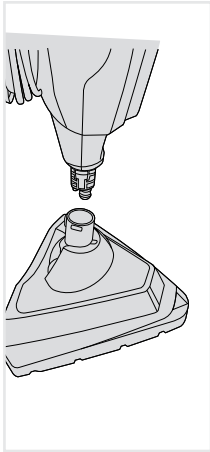

**1** Insert the body into the floor head until it clicks into place.



**2** Insert the handle until it clicks into place.

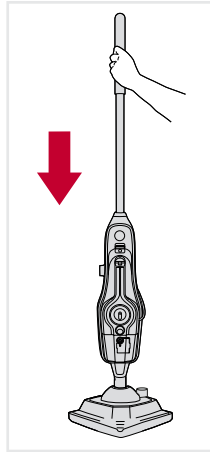

**3** To stand steam mop upright, push handle down until clicks into place.

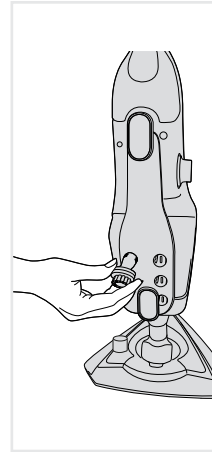

**4** Insert tools into the back of the steam mop.

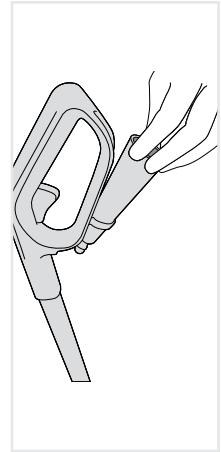

**5** Insert concentration nozzle into the storage hook on the back of handle.

## Cord storage:

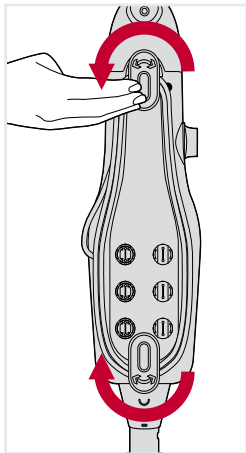

- 1 Wrap cord around cord release hooks.

## Attach microfiber pad:

### ⚠ WARNING ⚠

To reduce the risk of personal injury -  
Unplug the steam cleaner when  
assembling the accessories.

### • IMPORTANT •

Never use the Steam Mop without  
the Microfiber Pad correctly  
attached to the Mop Head.

The “Multi-Surface Microfiber Pad” can be used on all sealed hard floor surfaces as well as carpet. When using on carpet the carpet glider attachment should be utilized as directed in the “Refreshing Carpet” section of this manual.

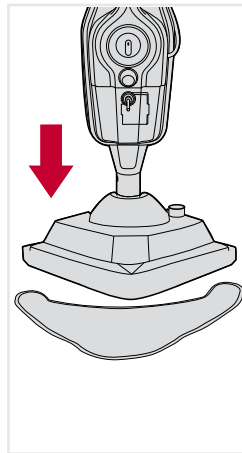

- 1 Place the cleaning pad on the floor white side facing up. Place steam mop on top of pad making sure the Mop Head covers the entire pad. Hook and loop feature on the bottom of the mop will hold the pad in place.

# How to use:

1. Handle
2. Solution Trigger (behind)
3. Handheld release button
4. Handheld Steam Trigger
5. Solution Control Dial
6. Steam Ready Indicator
7. Steam Control Dial
8. On/Off Switch
9. Water Tank
10. Hard Water Filter (hidden)
11. Tile & Grout Scrub Brush (hidden)
12. Floorhead
13. SteamStream™ on/off button
14. Concentration Nozzle Storage
15. Handle Release Button
16. Solution Tank
17. Quick Cord Release Hook
18. Tool Storage
19. Floorhead Release Button
20. Carpet Glider

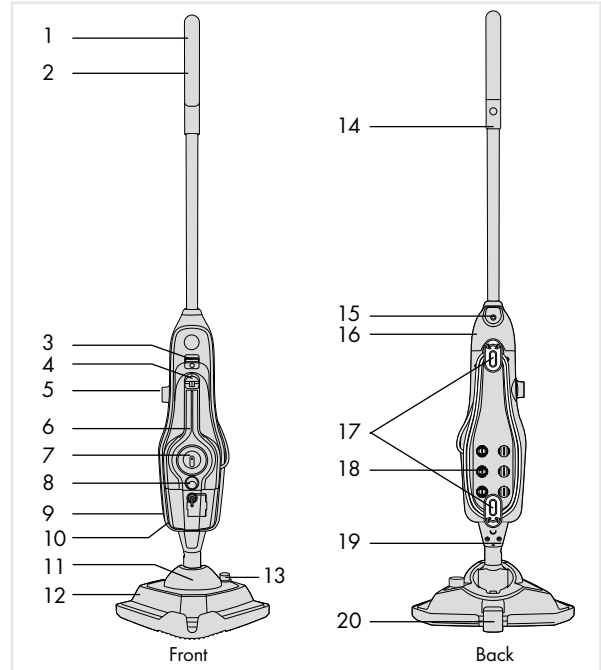

## Accessories:

- 21. Multi-Surface Microfiber Pad\*
- 22. Carpet Glider
- 23. Water Filter (Pre-assembled in steam cleaner, remove tank to expose filter)
- 24. Cleaning Solution\*
- 25. Hose
- 26. Squeegee Tool\*\*
- 27. Upholstery Cloth Tool\*\*
- 28. Large Plastic Brush
- 29. Small Plastic Brush
- 30. Metal Brush
- 31. Grout Brush
- 32. Scraper Nozzle
- 33. Concentration Nozzle
- 34. Detail Nozzle
- 35. Accessory Bag

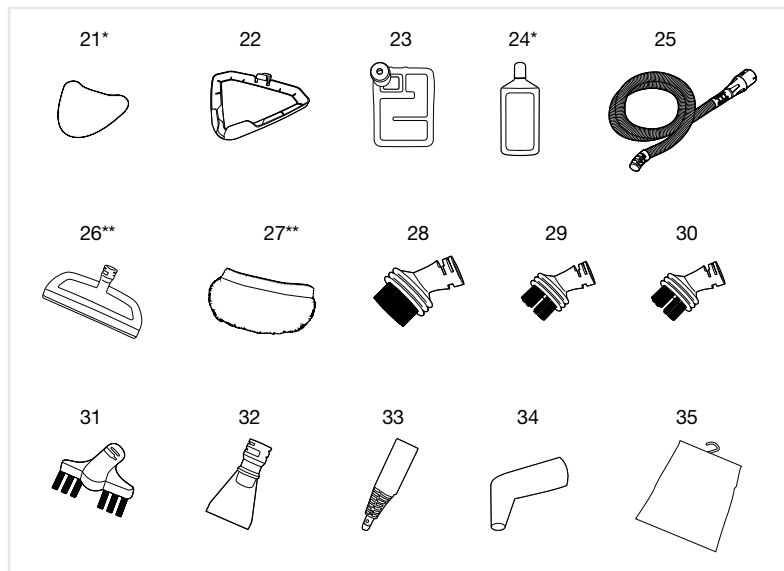

\*Quantities vary per model

\*\*Select models only

TECHNICAL SPECIFICATION  
Model Number: WH20440 series  
Input Power: AC 120V / 60Hz / 10A

# Before you begin cleaning:

## Filling the twin tanks

### ⚠ WARNING ⚠

To avoid the risk of personal injury - Turn off, unplug, and allow steam cleaner to cool before servicing or filling water or solution tank. Do not use hot or boiling water to fill water tank.

### • IMPORTANT •

DO NOT MIX HOOVER® 4X STEAM MULTI-FLOOR CLEANING SOLUTION WITH ANY OTHER CLEANING SOLUTION.

### • IMPORTANT •

DO NOT ADD SOLUTION TO WATER TANK.

NOTE: When the tank is turned upright it may allow a few drops to drip from cap. This is normal.

### • IMPORTANT •

If you don't want to use solution on your flooring, turn solution dial to OFF position.

Always test on an inconspicuous area of flooring first before using solution.

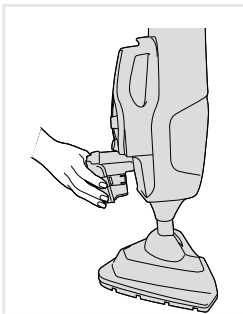

**1** Press the water tank release buttons and pull the water tank to remove.

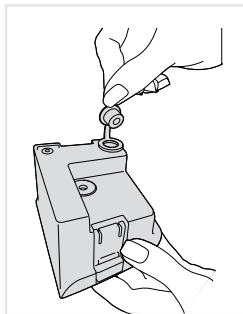

**2** Pull the tab on the water tank cap to open.

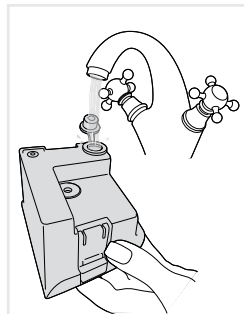

**3** Fill the water tank with water only to fill line, replace the cap and push firmly to close.

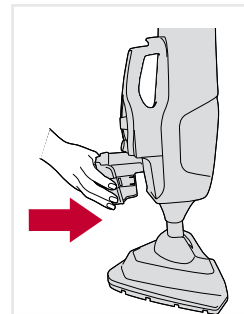

**4** Slide the water tank back into the machine until it clicks into place.

**⚠ WARNING ⚠**  
Only use recommended Hoover® 4x  
Steam Multi-Floor Cleaning Solution.

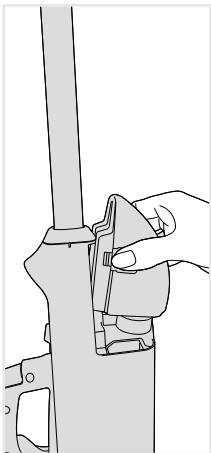

**5** To remove the solution tank press both release buttons and pull to release.

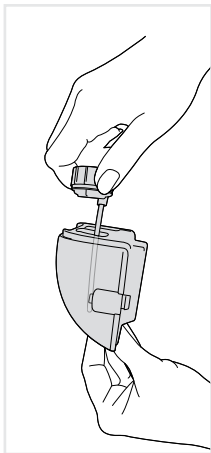

**6** Twist the solution tank cap counter clockwise and lift to remove.

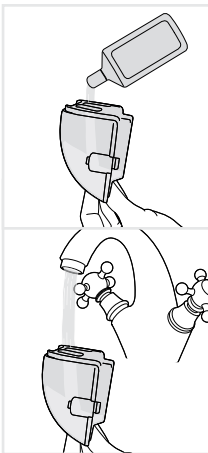

**7** Pour solution to the solution fill line. Then fill remainder with water. See tank fill lines for reference.

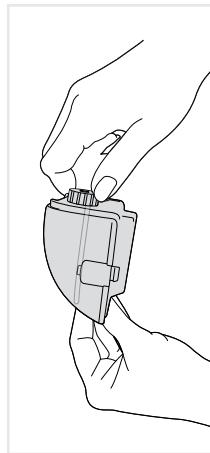

**8** Replace the solution tank cap and twist clockwise to close.

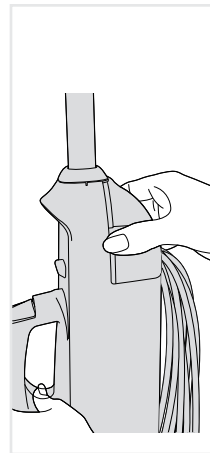

**9** Insert the solution tank back into the machine until it clicks into place.

- The steam mop and accessories get very hot during use, always allow them to cool down before handling.
- Always unplug and switch off the steam mop when assembling.
- Always switch off the steam mop before emptying the water tank or changing the cleaning pads/accessories.
- **IMPORTANT:** Please refer to floor manufacturer's care recommendations before use and test the steam mop on a discrete area of flooring to begin with.
- When using the steam mop, basic safety precautions should always be observed.
- Don't aim the steam mop at people, animals, plants or electrical components such as interior of ovens or wires. Never touch the steam spray or floor head from a short distance. (There is a risk of scalding)
- The steam mop is equipped with a thermostat and a thermal cut out. If for any reason the steam mop overheats it will switch off. If this happens turn off and unplug the steam mop, allow to cool for a least 2 to 4 hours and re-start.

## Using your machine:

### **WARNING**

Never leave the Steam Mop in one spot on any surface for an extended period of time with a damp or wet Microfiber pad attached as this may damage the floor surface.

When cleaning hard floors, your Steam Mop should only be used on tiles, linoleum, sealed hardwood flooring, engineered hardwood, laminate, vinyl and sealed stone floors.

If used on waxed flooring, you may experience loss of glossiness.

To reduce the risk of personal injury, unplug the steam cleaner when assembling the accessories.

Do not clean over floor electrical outlets.

Do not use steam cleaner or press the Steam Trigger without water in the water tank.

### **IMPORTANT**

Never use the Steam Mop without the Microfiber pad properly attached to the Mop Head.

**⚠ WARNING ⚠**

To reduce the risk of personal injury - Unplug the steam cleaner when assembling the accessories.

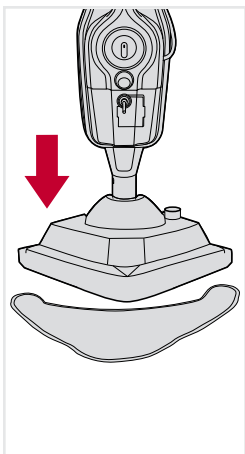

- 1** Place the microfiber pad on the floor white side facing up. Place steam mop onto pad making sure the entire pad covers the floor head.

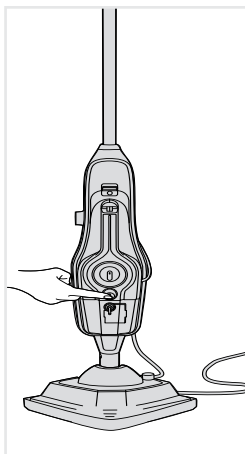

- 2** Plug into an outlet and Push On/Off switch to turn ON (I=ON). The blue light will illuminate to show power on. The green light will illuminate to show the steam mop is ready to use.

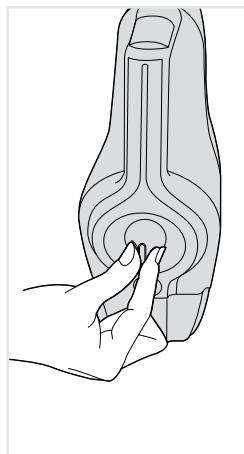

- 3** Adjust the steam dial to desired setting.



- 4** To steam your floors with solution turn the dial to ON (I=ON) and without solution turn the dial to OFF (0=OFF).

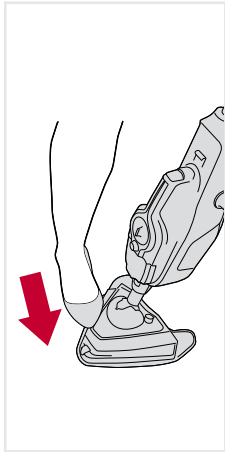

**5** To recline the steam mop place foot here and pull handle backwards.



**6** To produce steam squeeze the trigger in short bursts. Don't hold the trigger continuously to prevent over saturating floors.

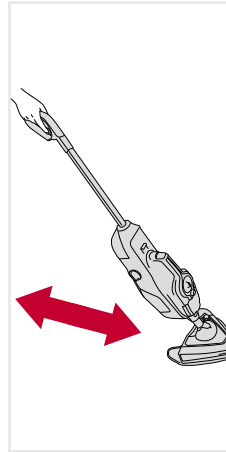

**7** Move the steam mop slowly backwards and forwards across the floor. Squeeze and release trigger as required.

## TO SANITIZE HARD SURFACES

Turn the solution dial to "OFF" position and steam control dial to "MAX" position.

Connect the microfiber pad and run a minimum of 6 strokes at a medium pace (5-7 seconds per 32" stroke) across same area. Allow to dry.

## Refreshing carpets:

### ⚠ WARNING ⚠

To reduce the risk of personal injury - Unplug the steam cleaner when assembling the accessories.

### ⚠ WARNING ⚠

Do not clean over floor electrical outlets.  
Do not use steam cleaner or press the Steam Trigger without water in the water tank.

### • IMPORTANT •

When using on carpets, always ensure the multi-surface Microfiber Pad is properly attached to the Mop Head.

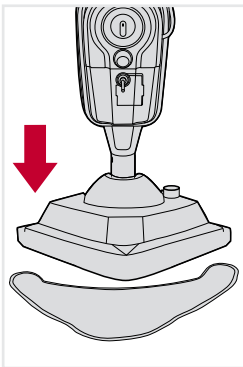

**1** Place the microfiber pad on the floor white side facing up. Place steam mop onto pad making sure the entire pad covers the floor head.

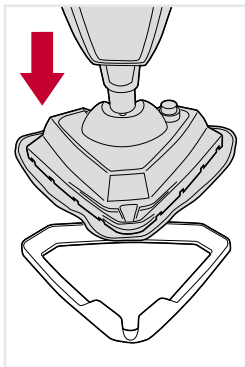

**2** With microfiber pad attached, hook the steam mop into the front of the carpet glider and push to clip into place. Carpet glider should only be used when refreshing carpets.



**3** Turn the solution dial to OFF when refreshing carpet.

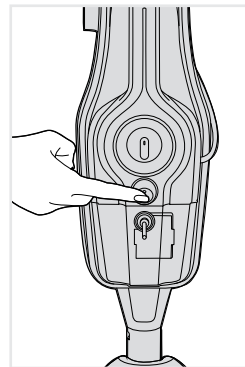

**4** Push On/Off button to power on and off.



**5** To recline the steam mop place foot on here and pull handle backwards.

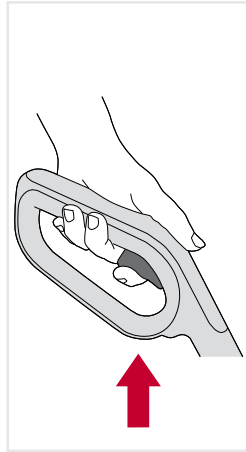

**6** To produce steam, squeeze the trigger. To prevent overly wetting the carpet, avoid holding the trigger continuously.

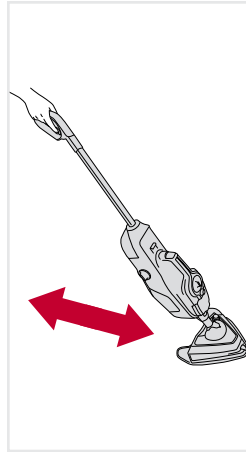

**7** Move the steam mop slowly backwards and forwards across the carpet.

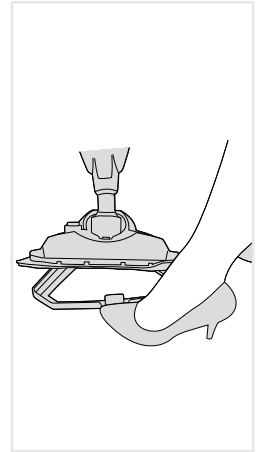

**8** To release the carpet glider, place foot on clip and push down. Lift steam mop to unhook and remove.

## Using tile and grout scrub brush and SteamStream™:

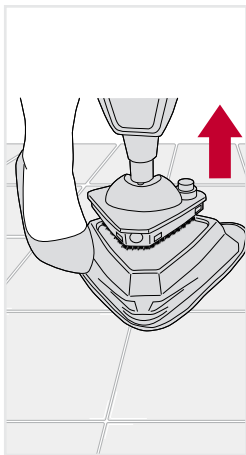

**1** Place foot on outer floor head and gently pull away steam mop to release the tile and grout scrub brush.

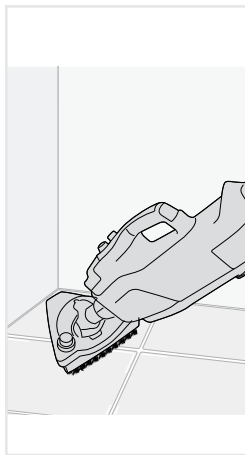

**2** Move steam mop back and forth across the floor, getting into corners and awkward places.

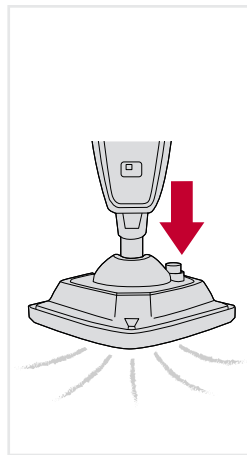

**3** To engage SteamStream™ from the front nozzle, press the SteamStream™ button to activate, and squeeze the trigger to release steam. Press the SteamStream™ button to turn OFF (0=OFF).

### ⚠ WARNING ⚠

Do not clean over floor electrical outlets.  
Do not use steam cleaner or press the Steam Trigger without water in the water tank.

### ⚠ WARNING ⚠

Scrub brush bristles may damage wood floors.

### • IMPORTANT •

Always switch off the steam mop before attaching or removing the floor head.

### • IMPORTANT •

Scrub brush only recommended for tile and grout cleaning only.

## Using the handheld steamer:

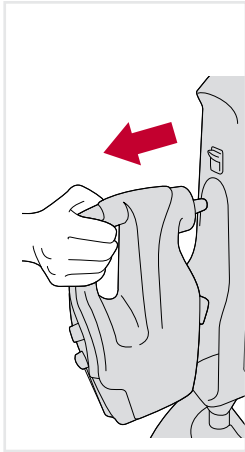

**1** Lift the handheld release button and gently pull the handheld to release from the steam mop.

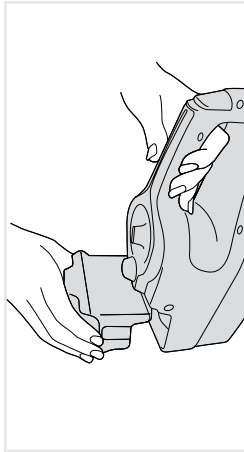

**2** Remove water tank and refill before use.

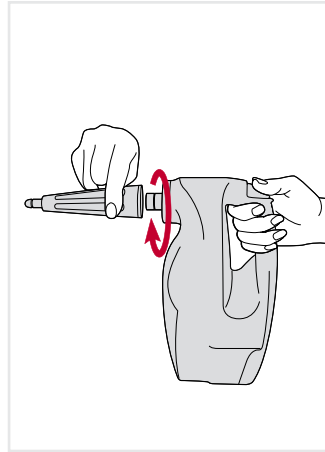

**3** When using the handheld always attach the concentration nozzle or hose. Push onto the handheld nozzle and twist clockwise to lock into position.

**⚠ WARNING ⚠**  
Turn off, unplug and allow steam cleaner to cool before servicing or filling water tank.

**⚠ CAUTION ⚠**  
Turn off, unplug and allow steam cleaner to cool before removing accessories. Always have the nozzle pointed away from you and others during installation.

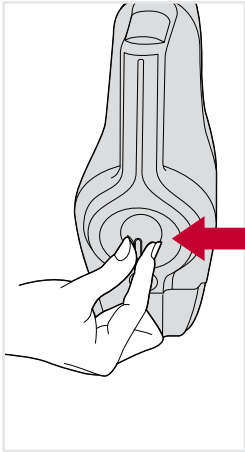

**4** Adjust the dial on the front of the handheld to desired steam setting.

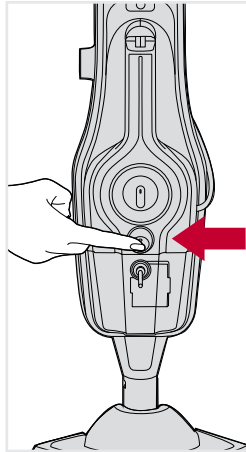

**5** To Turn unit ON, push switch to (I=ON).



**6** To produce steam push the trigger with your thumb in short bursts. Don't hold the trigger continuously to prevent over wetting.

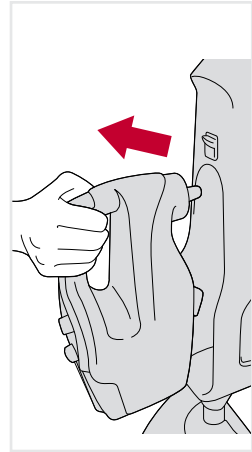

**7** Insert the handheld back into the machine until it clicks into place.

**⚠ WARNING ⚠**

To avoid burn injury, do not touch the steam cleaning nozzle or adjacent surfaces when steam cleaning or when the nozzle is heated.

## Using small accessories:

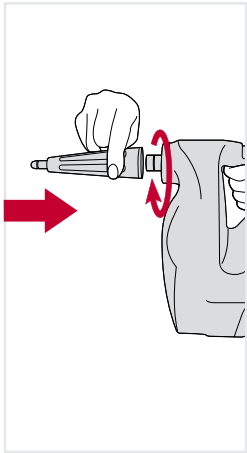

**⚠ CAUTION ⚠**  
Turn off, unplug, and allow steam cleaner to cool before removing accessories. Always have the nozzle pointed away from you and others during installation.

**1** Small tools can be attached via concentration nozzle. Twist clockwise until locked into position and secure. To remove concentration nozzle, turn counter-clockwise.

## Using large accessories:

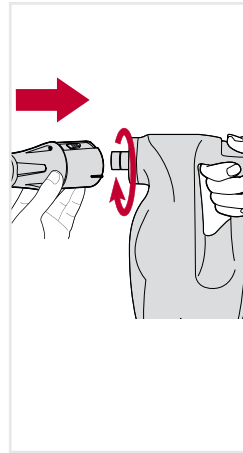

**1** Larger accessories can be attached using the concentration nozzle or hose. To attach the hose twist clockwise until locked into position and secure. To remove hose, turn counter-clockwise.

# Using the tools:

## Concentration nozzle



- 1** Use to remove soap scum in baths and shower enclosures and to clean heavily soiled areas in kitchens.

## Brushes

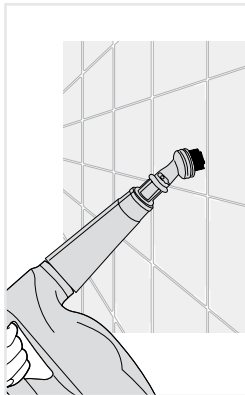

- 2** Ideal for any surface from tiles, sinks, toilets and oven tops.

## Squeegee tool\*



- 3** Great for leaving your windows, tiles and mirrors gleaming.

\* Select models only

## Upholstery/ cloth tool\*

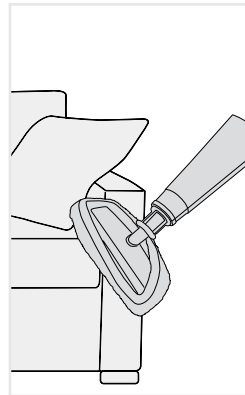

- 4** Attach the cloth to the squeegee tool for use on upholstery and clothes.

\* Select models only

• **IMPORTANT** •

Faucets should be turned off when steaming around them.

Don't steam clean ovens, oven surfaces or grills when hot. Allow to cool to room temperature.

**Grout brush**

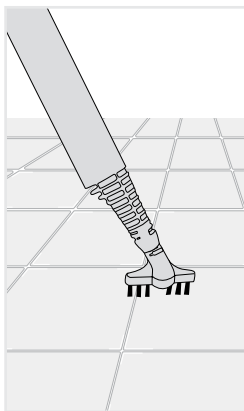

**5** Lifts embedded dirt from in between tiles.

**Detail nozzle**

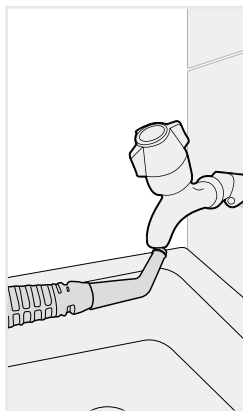

**6** For hard-to-reach areas e.g. around faucets.

**Scraper nozzle**

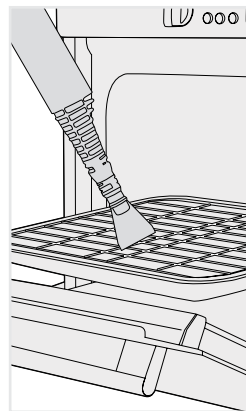

**7** Ideal for removing dried on residue from ovens, work surfaces and pans.

## Maintenance:

If steam cleaner is not working as it should, has been dropped, damaged, left outdoors, or dropped into water, call Customer Service at 1-800-944-9200 for further instruction before continuing use.

This steam cleaner contains no user serviceable parts. Do not try to repair it yourself.

### • IMPORTANT •

Allow the steam mop to fully cool down before performing any maintenance or troubleshooting checks.

### Emptying the water tank

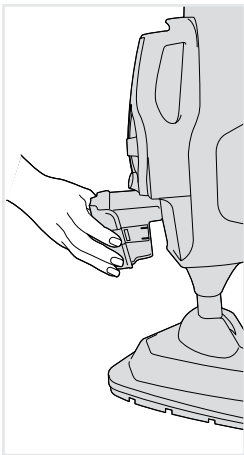

**1** Press the water tank release button and lift the water tank by the handle.

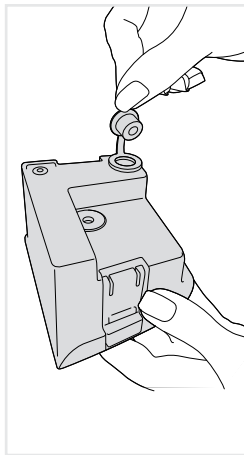

**2** Pull the tab on the water tank to open.

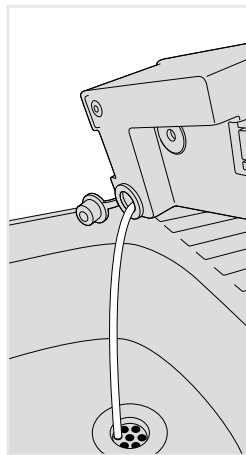

**3** Empty any excess water over the sink.

## Emptying the solution tank

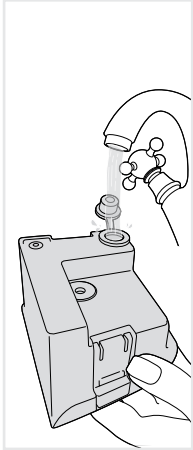

**4** Rinse water tank with water and push water tank tab firmly to close before replacing back onto the machine.

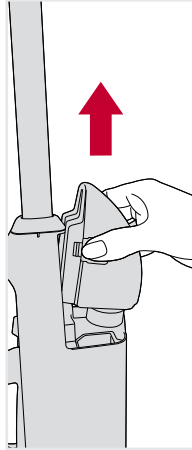

**5** Push both solution tank release buttons then lift to remove.

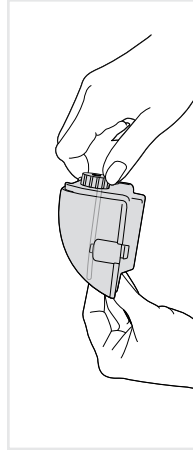

**6** Twist solution cap counter-clockwise and lift to remove.

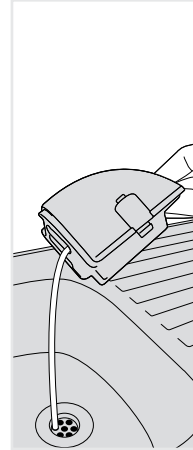

**7** Empty any excess solution over the sink.

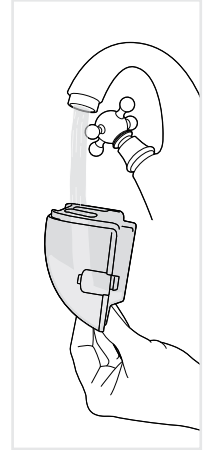

**8** Rinse solution tank with water and replace solution tank cap, turn clockwise to tighten before replacing back onto the machine.

## Removing cleaning pads

### ⚠ WARNING ⚠

To reduce the risk of personal injury -  
Unplug Steam Mop before servicing  
and allow to cool.

### • IMPORTANT •

Never use bleach or fabric softener  
when washing the pad.

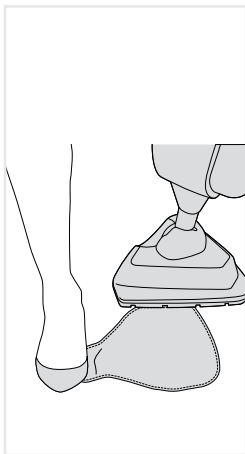

**1** Hold corner of pad down  
with foot and lift steam  
mop to peel away.

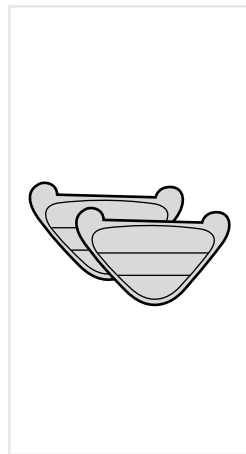

**2** All cleaning pads are machine  
washable on WARM setting.  
For best results lay flat to dry.  
Allow to fully dry before use.

## Replacing the hard water filter

### ⚠ WARNING ⚠

To reduce the risk of personal injury -  
Unplug Steam Mop before servicing  
and allow to cool.

### • IMPORTANT •

The condition of the filter affects the performance  
of your machine.

Check and change filter (depending on level of  
use and water conditions in your area).

Do not operate Steam Mop without Water Filter in place.

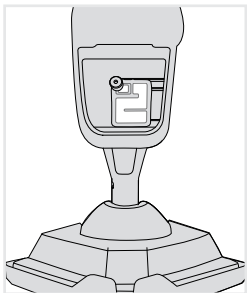

- 1** Remove the water tank to access the hard water filter.

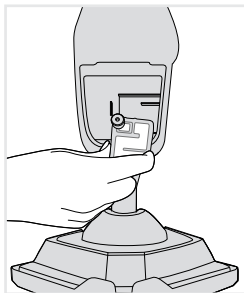

- 2** Pull to remove the hard water filter.

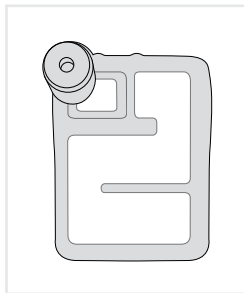

- 3** New filter has a (beige/cream color).

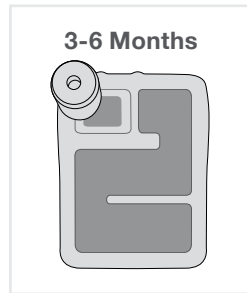

- 4** Hard water filter should be replaced every 3-6 Months or when discolored.

### WHAT TO BUY:

Contact a HOOVER® customer service representative at 1-800-944-9200 for replacement details:  
Part #440006653 or visit [www.hoover.com](http://www.hoover.com).

## Clearing blockages

**⚠ WARNING ⚠**  
To reduce the risk of personal injury - Unplug Steam Mop before servicing and allow to cool.

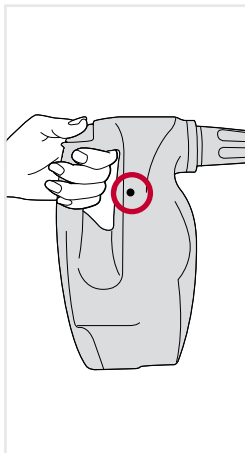

**1** If there is an obstruction to the steam flow through the machine, steam may release through the bleed valve.

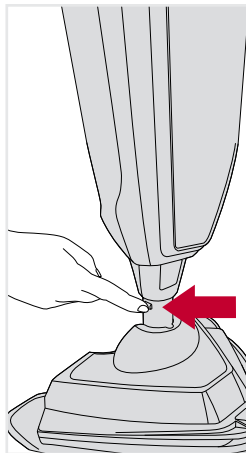

**2** To remove the floor head from the body push the floor head release button and lift.

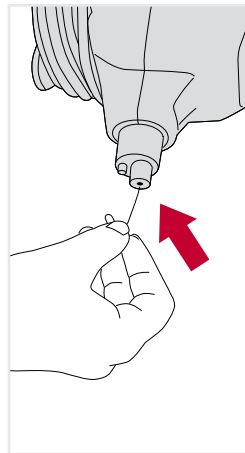

**3** After the floor head is removed, use a thin object such as a paper-clip (in the area shown), to remove the blockage.

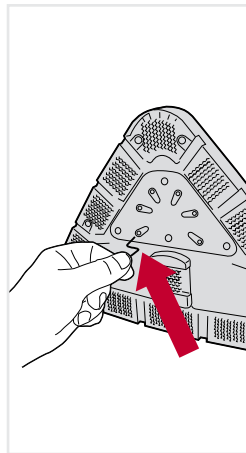

**4** With the pad removed from the floor head, insert a small thin object such as a paper-clip in to the steam holes to remove a blockage.

## Need Help?

If you need further assistance:

If your product needs servicing within the warranty period, please contact Customer Service at 1-800-944-9200; Mon-Fri 8am-7pm EST. Always identify your steam cleaner by the complete model number when requesting information or ordering parts. (The model number of the steam cleaner is located on the data plate)

**PLEASE DO NOT RETURN THIS STEAM CLEANER TO THE STORE.**

## Storage:

- Unplug the power cord.
- Allow time to cool.
- Empty the residual fluid from the twin tank and clean the external surface with a dry cloth. Allow to dry.
- Re-install twin tank.
- You may leave solution in solution tank for short period of time, but if you are going to leave solution in tank for more than 2 weeks, it is recommended to empty the solution tank.

### QUESTIONS OR CONCERNS?

Contact Us:

(800) 944-9200

Twitter: @HooverUSA

Facebook: facebook.com/hoover

**Do not return to store.** See back of product for model number.

# Troubleshooting:

This Steam Cleaner contains no user serviceable parts. Do not try to repair it yourself.

USE TROUBLESHOOTING GUIDE AS A FIRST STEP TO RESOLVE ANY PROBLEMS YOU MAY BE EXPERIENCING.

If steam cleaner is not working as it should, has been dropped, damaged, left outdoors, or dropped into water, call Customer Service at 1-800-944-9200 for further instruction before continuing use.

PROBLEM	POSSIBLE CAUSE	POSSIBLE SOLUTION
Steam Mop won't run	<ol style="list-style-type: none"><li>1. No voltage in wall plug.</li><li>2. Blown fuse or tripped breaker.</li><li>3. Steam cleaner may not be plugged into the electrical outlet correctly.</li><li>4. The electrical outlet may not be working properly, check the fuse or breaker, or consult an electrician.</li><li>5. The power cord may be damaged.</li><li>6. Does not turn on.</li></ol>	<ol style="list-style-type: none"><li>1. Check fuse or breaker in home.</li><li>2. Replace fuse or reset breaker in home.</li><li>3. Ensure the plug is pushed in securely.</li><li>4. Check fuse or breaker in home. Replace fuse/reset breaker in home.</li><li>5. If cord is damaged have it replaced by an authorized service representative.</li><li>6. Check the On/Off switch to make sure it is in the On position.</li></ol>
Steam mop not producing steam	<ol style="list-style-type: none"><li>1. Water tank may be empty.</li><li>2. The water tank may not be attached correctly.</li><li>3. Water Filter may be clogged and needs to be replaced.</li><li>4. Thermal protector may turn off pump if trying to operate steam cleaner before steam indicator is illuminated.</li><li>5. Steam path may be blocked.</li></ol>	<ol style="list-style-type: none"><li>1. Please refer to the "Filling Tanks" section.</li><li>2. Please refer to the "Filling Twin Tank" section, and ensure tank is fully seated.</li><li>3. Check Water Filter and clean or replace.</li><li>4. Unplug steam cleaner and allow to cool down</li><li>5. Please refer to the "Clearing Blockages" section.</li></ol>
Microfiber pad doesn't pick up dirt	<ol style="list-style-type: none"><li>1. The cleaning pad may already be saturated with dirt and needs washing.</li></ol>	<ol style="list-style-type: none"><li>1. Wash or replace with clean pad. Please refer to the "Removing Cleaning Pads" section.</li></ol>



## WARNING



To reduce the risk of personal injury - Unplug Steam Mop before servicing and allow to cool.

# SERVICE & WARRANTY

## SERVICE INFORMATION

ANY SERVICING SHOULD BE DONE BY AN AUTHORIZED SERVICE REPRESENTATIVE Call (888) 679-2121 USA & Canada

In the event that further assistance is required, visit an authorized service center. Find one nearest you by visiting our website at [www.hoover.com](http://www.hoover.com). Costs of any transportation to and from any place of repair are to be paid by the owner. Always identify your product by the model number and manufacturing code when requesting information or ordering replacement parts. (The model number and manufacturing code are on the back of the product)

### LIMITED ONE YEAR WARRANTY (DOMESTIC USE)

#### WHAT THIS WARRANTY COVERS

When used and maintained in normal household use and in accordance with the Owner's Manual, your HOOVER® product is warranted against original defects in material and workmanship for a full one year from date of purchase (the "Warranty Period"). During the Warranty Period, Hoover® will provide labor and parts, at no cost to you, to correct any such defect in products purchased in the United States, U.S. Military Exchanges and Canada.

#### HOW TO MAKE A WARRANTY CLAIM

If this product is not as warranted, take or send the product to either a Hoover® Sales and Service Center or Hoover® Authorized Warranty Service Dealer along with proof of purchase. For an automated referral to authorized service outlets in the U.S.A., phone: 1-800-944-9200 OR visit Hoover® online at [www.hoover.com](http://www.hoover.com). For additional assistance or information concerning this Warranty or the availability of warranty service outlets, phone the Hoover® Consumer Response Center, Phone 1-800-944-9200, Mon-Fri 8am-7pm EST. In Canada, contact Hoover® Canada, Carson Building, 100 Carson St., Etobicoke, Ontario M8W 3R9, Phone: 1-800-944-9200, Mon-Fri 8am-7pm EST.

#### WHAT THIS WARRANTY DOES NOT COVER

This Warranty does not cover: use of the product in a commercial operation (such as maid, janitorial and equipment rental services), improper

maintenance of the product, damage due to misuse, acts of God, nature, vandalism or other acts beyond the control of Hoover®, owner's acts or omissions, use outside the country in which the product was initially purchased and resales of the product by the original owner. This warranty does not cover pick up, delivery, transportation or house calls. However, if you mail your product to a Hoover® Sales and Service Center for warranty service, cost of shipping will be paid one way.

This warranty does not apply to products purchased outside the United States, including its territories and possessions, outside a U.S. Military Exchange and outside of Canada. This warranty does not cover products purchased from a party that is not an authorized retailer, dealer, or distributor of Hoover® products.

#### OTHER IMPORTANT TERMS

This Warranty is not transferable and may not be assigned. This Warranty shall be governed and construed under the laws of the state of Ohio. The Warranty Period will not be extended by any replacement or repair performed under this Warranty.

THIS WARRANTY IS THE EXCLUSIVE WARRANTY AND REMEDY PROVIDED BY HOOVER®. ALL OTHER WARRANTIES, EXPRESSED OR IMPLIED, INCLUDING WARRANTIES OF MERCHANTABILITY OR FITNESS FOR PARTICULAR PURPOSE, ARE DISCLAIMED. IN NO EVENT WILL HOOVER® BE LIABLE FOR ANY SPECIAL, INDIRECT, INCIDENTAL OR CONSEQUENTIAL DAMAGES OF ANY KIND OR NATURE TO OWNER OR ANY PARTY CLAIMING THROUGH OWNER, WHETHER BASED IN CONTRACT, NEGLIGENCE, TORT OR STRICT PRODUCTS LIABILITY OR ARISING FROM ANY CAUSE WHATSOEVER. Some states do not allow the exclusion of consequential damages, so the above exclusion may not apply to you. This warranty gives you specific rights; you may also have others that vary from state to state.



#RethinkCleaning

Hoover.com

Find us on:



[youtube.com/hover](https://youtube.com/hover)



[facebook.com/hover](https://facebook.com/hover)



[twitter.com/hoverusa](https://twitter.com/hoverusa)