



HIT-HY 200-A V3 HIT-HY 200-R V3 INJECTION MORTAR

Product Technical Datasheet
Steel-to-concrete
Update: Jan 25



HIT-HY 200-A V3 and HIT-HY 200-R V3 injection mortars

Anchor design (EN 1992-4, EOTA TR 082) / Rods, Sleeves and Rebar / Concrete

Injection mortar system	Benefits
	<p>Hilti HIT-HY 200-A V3</p> <ul style="list-style-type: none"> -  technology: Makes installation steps faster, simpler and safer. Automatic borehole cleaning with hollow drill bits, accurate dosing with HDE and fast and safe torquing with the adaptive torque (AT) system.
	<p>Hilti HIT-HY 200-R V3</p> <p>500 ml foil pack (also available as 330 ml foil pack)</p> <ul style="list-style-type: none"> - Suitable for uncracked and cracked concrete C20/25 to C50/60
	<p>Anchor rod (M8-M30): HAS, HAS HDG, HAS A4, HAS-U, HAS-U HDG, HAS-U A4, HAS-U HCR</p> <ul style="list-style-type: none"> - ETA Approved for seismic performance category C1, C2 - Maximum load performance in cracked concrete and uncracked concrete - High corrosion / corrosion resistance
	<p>Internally threaded sleeve (M8-M20): HIS-N HIS-RN</p> <ul style="list-style-type: none"> - Small edge distance and anchor spacing possible - Manual cleaning for borehole diameter up to 20mm and $h_{ef} \leq 10d$ for uncracked concrete only
	<p>Anchor rod (M8-M20): HIT-Z(-D TP) HIT-Z-F HIT-Z-R(-D TP)</p> <ul style="list-style-type: none"> - ETA data for 50 and 100 Years Working Life - Suitable for dry and water saturated concrete
	<p>Anchor rod (M12-M20): HAS-D</p> <ul style="list-style-type: none"> - Data under fire exposure in accordance with TR082 for threaded rod size M8 to M30
	<p>Rebar ($\phi 8 - \phi 32$)</p> <ul style="list-style-type: none"> - Anchorage is steel fibre-reinforced concrete with HAS-D



Application condition

Base material			Load conditions				
Concrete (uncracked)	Concrete (cracked)	Concrete (SFRC)	Static/ quasi-static	Seismic ETA-C1, C2	Fatigue ETA	Fire resistance	
Drilling, cleaning, setting			Other information				
Hammer drilled holes	Diamond cored holes	Hollow Drill Bit drilled holes	Water-filled borehole in concrete	Variable embedment depth	ETA 100 Years Working Life	PROFIS Engineering Software	Steel to concrete Handbook

Linked Approvals/Certificates and Instructions for use.

Approvals/certificates

Approval no	Application / loading condition	Authority / Laboratory	Date of issue
ETA-19/0601 (HAS, HIS-N, rebar)	Static and quasi-static / Seismic / Fire	DIBt, Berlin	29-01-2024
ETA-19/0632 (HIT-Z)	Static and quasi-static / Seismic	DIBt, Berlin	08-06-2023
ETA-18/0972 (HAS-D)	Static and quasi-static	DIBt, Berlin	26-09-2024
ETA-15/0296 (HIT-Z-D-TP)	Static and quasi-static / Seismic	DIBt, Berlin	18-07-2023
ETA-18/0978 (HAS-D)	Static and quasi-static / Fatigue	DIBt, Berlin	26-09-2024
ETA-19/0802 (HIT-Z-D-TP)	Static and quasi-static / Fatigue	DIBt, Berlin	18-09-2024
No.: 01/2024 (HAS, HIS-N, rebar)	120-years working life based on ETA-19/0601	BERGMEISTER, Vienna	18-03-2024

Approvals/certificates for normal weight concrete with maximum steel fibre content of 80 kg/m³

Approval no	Application / loading condition	Authority / Laboratory	Date of issue	Date of expiry
Z-21.3-2155 (HAS-D)	Fatigue applications in Steel Fibre Reinforced Concrete (SFRC)	DIBt, Berlin	19-03-2024	19-03-2029

The instructions for use can be viewed using the link in the instructions for use table or the QR code/link in the Hilti webpage table

Link to Instructions for use(IFU)

Material			
Injection mortar	IFU Hilti HIT-HY 200 A V3	IFU Hilti HIT-HY 200-R V3	-
Accessory	IFU Filling set		
Dispenser	IFU HDM	IFU HDE 500-22	IFU HDE 500-A12

Links to Hilti Webpage

Injection mortars / Dispenser / Accessories					
HIT-HY 200-A V3	HIT-HY 200-R V3	HDE 500-22	HDE 500-A12	HDM 500	Filling set
Fastener: Threaded rod					
HAS-U 8.8	HAS 8.8	HIS-N	HIT-Z	HIT-Z-D-TP	HAS-D

Fastener special dimensions

Mechanical properties and dimensions HAS and HAS-U

Mechanical properties and dimensions of the threaded rods are standardized and can be taken from the ETA listed in the table Approvals / Certificates.

Mechanical properties and dimensions HIS-N

Mechanical properties of the internal threaded sleeve can be taken from the ETA listed in the table Approvals / Certificates.

Dimensions for HIS-N and HIS-RN

Anchor size			M8	M10	M12	M16	M20
Diameter of element	d	[mm]	12,5	16,5	20,5	25,4	27,6
Length of element	L	[mm]	90	110	125	170	205
Thread engagement length; min - max	h_s	[mm]	8-20	10-25	12-30	16-40	20-50

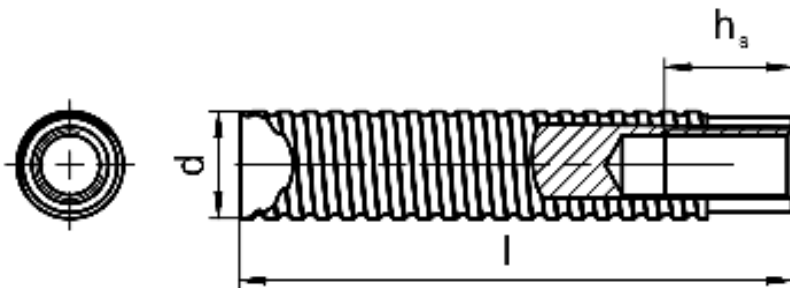

Mechanical properties and dimensions rebar

Mechanical properties and dimensions of the rebars are standardized and can be taken from the ETA.

Material quality

Part	Material
Rebar EN 1992-1-1:2004	Bars and de-coiled rods class B or C according to NDP or NCL of EN 1992-1-1/NA

Mechanical properties and dimensions HIT-Z

Mechanical properties of the anchor rod HIT-Z can be taken from the ETA listed in the table Approvals/ Certificates.

Anchor dimension for HIT-Z^{a)}

Anchor size		M8	M10	M12	M16	M20
Diameter of element	d [mm]	8	10	12	16	20
Length of anchor	min l [mm]	80	95	105	155	215
	max l [mm]	120	160	196	420	450
Helix length	l _{Helix} [mm]	30	50	60	96	100

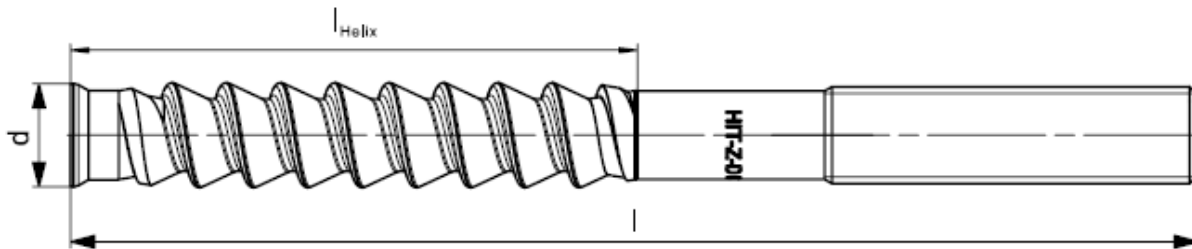

Mechanical properties and dimensions HAS-D

Mechanical properties of the anchor rod HAS-D can be taken from the ETA listed in the table Approvals / Certificates.

Anchor dimension for HAS-D

Anchor size		M12	M16	M20
Shaft diameter	d _k [mm]	12,5	16,5	22,0
Fastener length l	min l [mm]	143	180	242
	max L [mm]	531	565	623

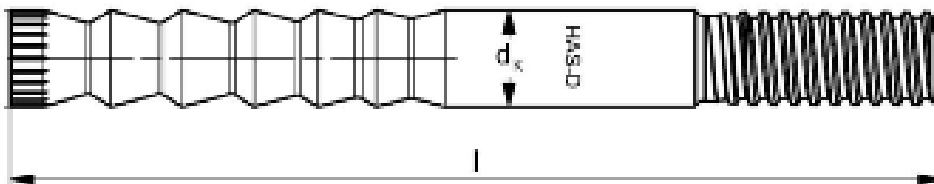

Mechanical properties and dimensions filling washer for use with standard nut and 1,5 d nut

Mechanical properties of filling washer can be taken from the ETA listed in the table Approvals / Certificates.

Dimensions filling washer and 1,5 d nut

Anchor size			M10	M12	M16	M20	M24
Diameter	d_{vs}	[mm]	42	44	52	60	70
Height of filling washer	h_{vs}	[mm]	5	5	6	6	6
Height of filling washer and spherical washer	h_{fs}	[mm]	9	10	11	13	15
Height of 1,5 d nut	h	[mm]	15	18	24	30	36

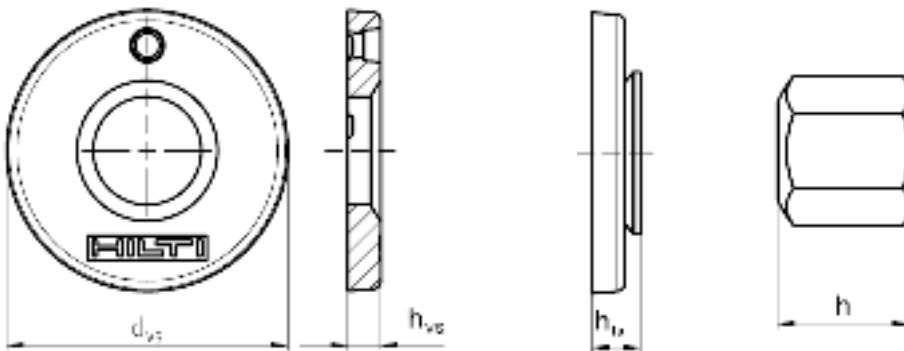



**Static and quasi-static loading based on ETA-19/0601, ETA-19/0632 and ETA-18/0972.
Design according to EN 1992-4**

All data in this section applies to:

- Correct setting (see setting instruction)
- For a single anchor
- Hammer drilled holes, hammer drilled holes with Hilti hollow drill bit
- No edge distance and spacing influence (see setting detail tables with characteristic distances)
- Minimum base material thickness, as specified in the table of this section
- Embedment depth, as specified in the table of this section
- Anchor material, as specified in the tables of this section (HIS-N with screw grade 8.8 and HIS-RN with screw grade 70)
- Concrete C20/25 with and without steel fibre for HAS-D.
- Concrete C20/25 without steel fibre for all anchor types.
- Data given below are for 50 Years Working Life
- In-service temperature range I
(min. base material temp. -40°C, max. long/short term base material temp.: +24°C/40°C)
- Short term loading. For long term loading apply ψ_{sUS} acc. to EN 1992-4
Hammer drilled holes, hammer drilled holes with hollow drill bit $\psi_{sUS}^0 = 0,88$
- Recommended loads: With overall partial safety factor for action $\gamma = 1,4$.

For specific design cases refer to [PROFIS Engineering](#).

Embedment depth ¹⁾ and base material thickness

Anchor size		M8	M10	M12	M16	M20	M24	M27	M30
HAS, HAS-U									
Embedment depth	h_{ef} [mm]	80	90	110	125	170	210	240	270
Base material thickness	h [mm]	110	120	140	160	220	270	300	340
HIS-N									
Embedment depth	h_{ef} [mm]	90	110	125	170	205	-	-	-
Base material thickness	h [mm]	120	150	170	230	270	-	-	-
HIT-Z(-D TP)									
Embedment depth	h_{ef} [mm]	70	90	110	145	180	-	-	-
Base material thickness	h [mm]	130	150	170	245	280	-	-	-
HAS-D									
Embedment depth	h_{ef} [mm]	-	-	100	125	170	-	-	-
Base material thickness	h [mm]	-	-	130	160	220	-	-	-

Rebar size		φ8	φ10	φ12	φ14	φ16	φ20	φ25	φ26	φ28	φ30	φ32
Rebar B500 B												
Embedment depth	h_{ef} [mm]	80	90	110	125	125	170	210	240	270	270	300
Base material thickness	h [mm]	110	120	145	165	165	220	275	305	340	345	380

1) The allowed range of embedment depth is shown in the setting details.

Design resistance

Anchor size		M8	M10	M12	M16	M20	M24	M27	M30	
Uncracked concrete										
Tension	HAS 5.8, HAS-U 5.8	N _{Rd} [kN]	12,2	19,3	28,1	45,8	72,7	99,8	121,9	145,5
	HAS 8.8, HAS-U 8.8		19,5	28,0	37,8	45,8	72,7	99,8	121,9	145,5
	HAS A4, HAS-U A4		13,7	21,7	31,6	45,8	72,7	99,8	80,2	98,1
	HAS-U HCR		19,5	28,0	37,8	45,8	72,7	99,8	121,9	145,5
	HIS-N 8.8		16,7	30,7	44,7	72,7	77,3	-	-	-
	HIS-RN 70		13,9	21,9	31,6	58,8	69,2	-	-	-
	HIT-Z(-D TP)		16,0	25,3	33,3	57,3	79,2	-	-	-
	HAS-D		-	-	32,8	45,8	72,7	-	-	-
Shear	HAS 5.8, HAS-U 5.8	V _{Rd} [kN]	8,8	13,9	20,2	37,7	58,8	84,7	110,2	134,6
	HAS 8.8, HAS-U 8.8		11,7	18,6	27,0	50,2	78,4	113,0	146,9	179,5
	HAS A4, HAS-U A4		8,2	13,0	18,9	35,2	55,0	79,2	48,2	58,9
	HAS-U HCR		11,7	18,6	27,0	50,2	78,4	70,6	91,8	112,2
	HIS-N 8.8		10,4	18,4	27,2	50,4	46,4	-	-	-
	HIS-RN 70		8,3	12,8	19,2	35,3	41,5	-	-	-
	HIT-Z(-D TP)		9,6	15,2	21,6	38,4	58,4	-	-	-
	HAS-D		-	-	27,2	50,4	119,2	-	-	-
Cracked concrete										
Tension	HAS 5.8, HAS-U 5.8	N _{Rd} [kN]	10,0	17,7	26,3	32,1	50,9	69,9	85,4	101,8
	HAS 8.8, HAS-U 8.8		10,0	17,7	26,3	32,1	50,9	69,9	85,4	101,8
	HAS A4, HAS-U A4		10,0	17,7	26,3	32,1	50,9	69,9	80,2	98,1
	HAS-U HCR		10,0	17,7	26,3	32,1	50,9	69,9	85,4	101,8
	HIS-N 8.8		16,5	26,5	32,1	50,9	67,4	-	-	-
	HIS-RN 70		13,9	21,9	31,6	50,9	67,4	-	-	-
	HIT-Z(-D TP)		13,4	19,6	26,5	40,1	55,4	-	-	-
	HAS-D		-	-	22,9	32,1	50,9	-	-	-
Shear	HAS 5.8, HAS-U 5.8	V _{Rd} [kN]	8,8	13,9	20,2	37,7	58,8	84,7	110,2	134,6
	HAS 8.8, HAS-U 8.8		11,7	18,6	27,0	50,2	78,4	113,0	146,9	179,5
	HAS A4, HAS-U A4		8,2	13,0	18,9	35,2	55,0	79,2	48,2	58,9
	HAS-U HCR		11,7	18,6	27,0	50,2	78,4	70,6	91,8	112,2
	HIS-N 8.8		10,4	18,4	27,2	50,4	46,4	-	-	-
	HIS-RN 70		8,3	12,8	19,2	35,3	41,5	-	-	-
	HIT-Z(-D TP)		9,6	15,2	21,6	38,4	58,4	-	-	-
	HAS-D		-	-	27,2	50,4	101,8	-	-	-

Design resistance

Rebar B500B size		φ8	φ10	φ12	φ14	φ16	φ20	φ25	φ26	φ28	φ30	φ32
Uncracked concrete												
Tension	N _{Rd} [kN]	16,1	22,6	33,2	44,0	45,8	72,7	99,8	121,9	145,5	145,5	170,4
Shear	V _{Rd} [kN]	9,3	14,7	20,7	28,0	36,7	57,3	90,0	97,3	112,7	129,3	147,3
Cracked concrete												
Tension	N _{Rd} [kN]	-	9,4	19,4	25,7	29,3	49,8	69,9	85,4	101,8	101,8	119,3
Shear	V _{Rd} [kN]	-	14,7	20,7	28,0	36,7	57,3	90,0	97,3	112,7	129,3	147,3



Recommended load

Anchor size			M8	M10	M12	M16	M20	M24	M27	M30	
Uncracked concrete											
Tension	N _{rec}	[kN]	HAS 5.8, HAS-U 5.8	8,7	13,8	20,1	32,7	51,9	71,3	87,1	103,9
			HAS 8.8, HAS-U 8.8	13,9	20,0	27,0	32,7	51,9	71,3	87,1	103,9
			HAS A4, HAS-U A4	9,8	15,5	22,5	32,7	51,9	71,3	57,3	70,1
			HAS-U HCR	13,9	20,0	27,0	32,7	51,9	71,3	87,1	103,9
			HIS-N 8.8	11,9	21,9	31,9	51,9	55,2	-	-	-
			HIS-RN 70	9,9	15,7	22,5	42,0	49,4	-	-	-
			HIT-Z(-D TP)	11,4	18,1	23,8	40,9	56,6	-	-	-
			HAS-D	-	-	23,4	32,7	51,9	-	-	-
Shear	V _{rec}	[kN]	HAS 5.8, HAS-U 5.8	6,3	9,9	14,5	26,9	42,0	60,5	78,7	96,2
			HAS 8.8, HAS-U 8.8	8,4	13,3	19,3	35,9	56,0	80,7	104,9	128,2
			HAS A4, HAS-U A4	5,9	9,3	13,5	25,2	39,3	56,6	34,4	42,1
			HAS-U HCR	8,4	13,3	19,3	35,9	56,0	50,4	65,6	80,1
			HIS-N 8.8	7,4	13,1	19,4	36,0	33,1	-	-	-
			HIS-RN 70	6,0	9,2	13,7	25,2	29,6	-	-	-
			HIT-Z(-D TP)	6,9	10,9	15,4	27,4	41,7	-	-	-
			HAS-D	-	-	19,4	36,0	85,1	-	-	-
Cracked concrete											
Tension	N _{rec}	[kN]	HAS 5.8, HAS-U 5.8	7,2	12,6	18,8	22,9	36,3	49,9	61,0	72,7
			HAS 8.8, HAS-U 8.8	7,2	12,6	18,8	22,9	36,3	49,9	61,0	72,7
			HAS A4, HAS-U A4	7,2	12,6	18,8	22,9	36,3	49,9	57,3	70,1
			HAS-U HCR	7,2	12,6	18,8	22,9	36,3	49,9	61,0	72,7
			HIS-N 8.8	11,8	18,9	22,9	36,3	48,1	-	-	-
			HIS-RN 70	9,9	15,7	22,5	36,3	48,1	-	-	-
			HIT-Z(-D TP)	9,6	14,0	18,9	28,6	39,6	-	-	-
			HAS-D	-	-	16,4	22,9	36,3	-	-	-
Shear	V _{rec}	[kN]	HAS 5.8, HAS-U 5.8	6,3	9,9	14,5	26,9	42,0	60,5	78,7	96,2
			HAS 8.8, HAS-U 8.8	8,4	13,3	19,3	35,9	56,0	80,7	104,9	128,2
			HAS A4, HAS-U A4	5,9	9,3	13,5	25,2	39,3	56,6	34,4	42,1
			HAS-U HCR	8,4	13,3	19,3	35,9	56,0	50,4	65,6	80,1
			HIS-N 8.8	7,4	13,1	19,4	36,0	33,1	-	-	-
			HIS-RN 70	6,0	9,2	13,7	25,2	29,6	-	-	-
			HIT-Z(-D TP)	6,9	10,9	15,4	27,4	41,7	-	-	-
			HAS-D	-	-	19,4	36,0	72,7	-	-	-

Recommended load

Rebar B500B size			φ8	φ10	φ12	φ14	φ16	φ20	φ25	φ26	φ28	φ30	φ32
Uncracked concrete													
Tension	N _{rec}	[kN]	11,5	16,2	23,7	31,4	32,7	51,9	71,3	87,1	103,9	103,9	121,7
Shear	V _{rec}	[kN]	6,7	10,5	14,8	20,0	26,2	41,0	64,3	69,5	80,5	92,4	105,2
Cracked concrete													
Tension	N _{rec}	[kN]	-	6,7	13,8	18,3	20,9	35,6	49,9	61,0	72,7	72,7	85,2
Shear	V _{rec}	[kN]	-	10,5	14,8	20,0	26,2	41,0	64,3	69,5	80,5	92,4	105,2

Seismic loading based on ETA-19/0601 and ETA-19/0632. Design according to EN 1992-4

All data in this section applies to:

- Correct setting (see setting instruction)
- For a single anchor
- Hammer drilled holes, hammer drilled holes with Hilti hollow drill bit
- No edge distance and spacing influence (see setting detail tables with characteristic distances)
- Minimum base material thickness, as specified in the table of this section
- Embedment depth, as specified in the table of this section
- Anchor material, as specified in the tables of this section
- Concrete C20/25
- Temperature range I (min. base material temp. -40°C, max. long/short term base material temp.: +24°C/40°C)
- $\alpha_{\text{gap}} = 1,0$ (using Hilti seismic filling set) or $\alpha_{\text{gap}} = 0,5$ (without using Hilti seismic filling set) accordingly

For specific design cases refer to [PROFIS Engineering](#).

Embedment depth ¹⁾ and base material thickness for seismic performance category C2

Anchor size			M12	M16	M20	M24
HAS, HAS-U						
Embedment depth	h_{ef}	[mm]	110	125	170	210
Base material thickness	h	[mm]	140	160	220	270
HIT-Z						
Embedment depth	h_{ef}	[mm]	110	145	180	-
Base material thickness	h	[mm]	170	245	280	-

Design resistance in case of seismic performance category C2

Anchor size			M12	M16	M20	M24
Tension	HAS 8.8, HAS-U 8.8	$N_{\text{Rd,C2}}$ [kN]	7,5	19,3	32,8	36,9
	HIT-Z		14,7	34,1	47,1	-
with Hilti filling set ($\alpha_{\text{gap}} = 1,0$)						
Shear	HAS 8.8, HAS-U 8.8	$V_{\text{Rd,C2}}$ [kN]	22,4	36,8	61,6	82,4
	HIT-Z		18,4	32,8	48,8	-
without Hilti filling set ($\alpha_{\text{gap}} = 0,5$)						
Shear	HAS 8.8, HAS-U 8.8	$V_{\text{Rd,C2}}$ [kN]	9,6	16,0	28,4	36,0
	HIT-Z		8,4	14,4	22,0	-



Embedment depth and base material thickness for seismic performance category C1

Anchor size			M8	M10	M12	M16	M20	M24	M27	M30
HAS, HAS-U										
Embedment depth	h_{ef}	[mm]	-	90	110	125	170	210	240	270
Base material thickness	h	[mm]	-	120	140	160	220	270	300	340
HIT-Z										
Embedment depth	h_{ef}	[mm]	70	90	110	145	180	-	-	-
Base material thickness	h	[mm]	130	150	170	245	280	-	-	-

Design resistance in case of seismic performance category C1

Anchor size			M8	M10	M12	M16	M20	M24	M27	M30
Tension	HAS 8.8, HAS-U 8.8	$N_{Rd,C1}$ [kN]	-	9,8	19,4	27,3	43,3	59,4	72,6	86,6
	HIT-Z; HIT-Z-R		11,4	16,7	22,5	34,1	47,1	-	-	-
with Hilti filling set ($\alpha_{gap} = 1,0$)										
Shear	HAS 8.8, HAS-U 8.8	$V_{Rd,C1}$ [kN]	-	18,6	27,0	50,2	78,4	113,0	-	-
	HIT-Z		6,8	9,6	12,8	22,4	36,0	-	-	-
	HIT-Z-R		7,8	12,0	17,6	24,8	38,4	-	-	-
without Hilti filling set ($\alpha_{gap} = 0,5$)										
Shear	HAS 8.8, HAS-U 8.8	$V_{Rd,C1}$ [kN]	-	9,3	13,5	25,1	39,2	56,5	73,4	89,8
	HIT-Z		3,4	4,8	6,4	11,2	18,0	-	-	-
	HIT-Z-R		3,9	6,0	8,8	12,4	19,2	-	-	-

Fatigue loading based on ETA-18/0978 and ETA-19/0802
Design according to EN 1992-4

All data in this section applies to:

- Correct setting (see setting instruction)
- For a single anchor
- Hammer drilled holes, hammer drilled holes with Hilti hollow drill bit
- No edge distance and spacing influence (see setting detail tables with characteristic distances)
- Minimum base material thickness, as specified in the table of this section
- Embedment depth, as specified in the table of this section
- Anchor material, as specified in the tables of this section
- Concrete C20/25
- FOR HAS-D: In-service temperature range I
(min. base material temp. -40°C, max. long/short term base material temp.: +50°C/80°C)
- FOR HIT-Z(-R)-D TP: In-service temperature range I
(min. base material temp. -40°C, max. long/short term base material temp.: +24°C/40°C)

For specific design cases refer to [PROFIS Engineering](#).

Anchorage depth

Anchor size			M12	M16	M20
HAS-D					
Embedment depth	h_{ef}	[mm]	100	125	170
Base material thickness	h	[mm]	130	160	220
HIT-Z-D TP, HIT-Z-R-D TP, HIT-Z					
Embedment depth	h_{ef}	[mm]	-	125	140
Base material thickness ^{a)}	h	[mm]	-	160/225 ^{a)}	185/240 ^{a)}

a) Values show for Drill hole condition (1) and (2) respectively. See setting details

Design resistance

Anchor size			M12	M16	M20	
Concrete cracked and uncracked						
Tension	HAS-D	$\Delta N_{Rd,0,\infty}$	[kN]	14,9	25,2	32,2
	HIT-Z-D TP			-	13,9	-
	HIT-Z-R-D TP			-	9,2	-
	HIT-Z			-	-	13,9
Shear	HAS-D	$\Delta V_{Rd,0,\infty}$	[kN]	6,1	11,1	15,6
	HIT-Z-D TP			-	5,9	-
	HIT-Z-R-D TP			-	5,9	-
	HIT-Z			-	-	5,9



Fire loading based on ETA-19/0601. Design according to EOTA TR 082

All data in this section applies to:

- In case of fire a partial safety factor $\gamma_{M,fi} = 1,0$ is taken (in absence of other national recommendations)
- Correct setting (see setting instructions)
- For a single anchor
- Hammer drilled holes, hammer drilled holes with Hilti hollow drill bit
- No edge distance and spacing influence (see setting detail tables with characteristic distances)
- Fire attack from side only
- Minimum base material thickness, as specified in the table of this section
- Embedment depth, as specified in the table of this section
- Anchor material, as specified in the tables of this section
- Concrete C20/25

For specific design cases refer to [PROFIS Engineering](#).

Anchorage depth in case of fire

Anchor size			M8	M10	M12	M16	M20	M24	M27	M30
HAS 5.8, HAS-U 5.8, HAS A4, HAS-U A4										
Embedment depth (minimum)	$h_{ef,min}$	[mm]	60	60	72	80	90	96	108	120
Base material thickness for $h_{ef,min}$	$h \geq$	[mm]	100	100	105	120	135	155	170	190
Embedment depth (intermediate)	$h_{ef,med}$	[mm]	80	90	96	112	120	120	135	150
Base material thickness for $h_{ef,med}$	$h \geq$	[mm]	110	120	125	150	165	180	195	220
Embedment depth (maximum)	$h_{ef,max}$	[mm]	160	200	240	320	400	480	540	600
Base material thickness for $h_{ef,max}$	$h \geq$	[mm]	190	230	270	360	445	540	600	670

Design resistance in case of fire

Anchor size				M8	M10	M12	M16	M20	M24	M27	M30		
HAS 5.8, HAS-U 5.8													
Tension	30 min	$h_{ef,min}$	$N_{Rd,fi(30)}$	[kN]	0,34	0,29	0,70	0,99	1,54	1,93	3,28	5,20	
		$h_{ef,med}$			1,04	1,80	2,66	4,63	5,75	5,48	8,64	12,88	
		$h_{ef,max}$			1,04	1,80	2,80	5,22	8,15	11,74	15,27	18,67	
	60 min	$h_{ef,med}$	$N_{Rd,fi(60)}$	[kN]	0,32	0,58	0,74	1,42	1,72	1,37	2,38	3,94	
		$h_{ef,max}$			0,81	1,36	2,05	3,83	5,98	8,62	11,21	13,70	
	90 min	$h_{ef,med}$	$N_{Rd,fi(90)}$	[kN]	0,10	0,19	0,26	0,53	0,65	0,47	0,87	1,55	
		$h_{ef,max}$			0,58	0,91	1,31	2,44	3,81	5,49	7,14	8,73	
	120 min	$h_{ef,max}$	$N_{Rd,fi(120)}$	[kN]	0,47	0,69	0,93	1,74	2,72	3,92	5,10	6,24	
	Shear	30 min	$h_{ef,min}$	$V_{Rd,fi(30)}$	[kN]	1,04	1,80	2,80	5,22	8,15	11,74	15,27	18,67
			$h_{ef,med}$			1,04	1,80	2,80	5,22	8,15	11,74	15,27	18,67
			$h_{ef,max}$			1,04	1,80	2,80	5,22	8,15	11,74	15,27	18,67
		60 min	$h_{ef,med}$	$V_{Rd,fi(60)}$	[kN]	0,81	1,36	2,05	3,83	5,98	8,62	11,21	13,70
$h_{ef,max}$			0,81			1,36	2,05	3,83	5,98	8,62	11,21	13,70	
90 min		$h_{ef,med}$	$V_{Rd,fi(90)}$	[kN]	0,58	0,91	1,31	2,44	3,81	5,49	7,14	8,73	
		$h_{ef,max}$			0,58	0,91	1,31	2,44	3,81	5,49	7,14	8,73	
120 min		$h_{ef,max}$	$V_{Rd,fi(120)}$	[kN]	0,47	0,69	0,93	1,74	2,72	3,92	5,10	6,24	

Design resistance in case of fire

Anchor size				M8	M10	M12	M16	M20	M24	M27	M30		
HAS A4, HAS-U A4													
Tension	30 min	$h_{ef,min}$	$N_{Rd,fi(30)}$	[kN]	0,68	0,68	1,57	2,53	4,23	5,67	9,31	14,12	
		$h_{ef,med}$			2,12	3,49	4,68	8,78	11,92	12,85	19,53	27,85	
		$h_{ef,max}$			2,70	4,93	7,93	14,77	23,06	33,23	43,20	52,81	
	60 min	$h_{ef,min}$	$N_{Rd,fi(60)}$	[kN]	0,09	0,08	0,26	0,43	0,79	1,03	2,05	3,61	
		$h_{ef,med}$			0,60	1,14	1,54	3,21	4,31	4,07	7,05	11,21	
		$h_{ef,max}$			1,93	3,49	5,56	10,37	16,18	23,31	30,31	37,05	
	90 min	$h_{ef,med}$	$N_{Rd,fi(90)}$	[kN]	0,19	0,42	0,58	1,36	1,81	1,50	2,97	5,17	
		$h_{ef,max}$			1,17	2,04	3,20	5,96	9,30	13,40	17,42	21,29	
	120 min	$h_{ef,max}$	$N_{Rd,fi(120)}$	[kN]	0,79	1,32	2,01	3,75	5,86	8,44	10,98	13,42	
	Shear	30 min	$h_{ef,min}$	$V_{Rd,fi(30)}$	[kN]	2,70	4,93	7,93	14,77	23,06	31,09	41,74	52,81
			$h_{ef,med}$			2,70	4,93	7,93	14,77	23,06	33,23	43,20	52,81
			$h_{ef,max}$			2,70	4,93	7,93	14,77	23,06	33,23	43,20	52,81
60 min		$h_{ef,min}$	$V_{Rd,fi(60)}$	[kN]	1,93	3,49	5,56	10,37	16,18	23,31	30,31	37,05	
		$h_{ef,med}$			1,93	3,49	5,56	10,37	16,18	23,31	30,31	37,05	
		$h_{ef,max}$			1,93	3,49	5,56	10,37	16,18	23,31	30,31	37,05	
90 min		$h_{ef,med}$	$V_{Rd,fi(90)}$	[kN]	1,17	2,04	3,20	5,96	9,30	13,40	17,42	21,29	
		$h_{ef,max}$			1,17	2,04	3,20	5,96	9,30	13,40	17,42	21,29	
120 min		$h_{ef,max}$	$V_{Rd,fi(120)}$	[kN]	0,79	1,32	2,01	3,75	5,85	8,44	10,98	13,42	

Setting information

Installation temperature:

- -10 °C to +40 °C (for HAS, HAS-U, HAS-D, HIS-N)
- +5 °C to +40 °C (for HIT-Z)

In-service temperature range

Hilti HIT-HY 200-A V3 and HIT-HY 200-R V3 injection mortars with anchor rod HAS / HAS-U / HIS-N / Rebar / HIT-Z / HAS-D may be applied in the temperature ranges given below. For the intended temperature range specified in the design, the respective bond strength values shall be taken from the ETA.

Temperature in the base material

Temperature range	Base material temperature	Maximum long term base material temperature	Maximum short term base material temperature
Temperature range I	-40 °C to +40 °C	+24 °C	+40 °C
Temperature range II	-40 °C to +80 °C	+50 °C	+80 °C
Temperature range III	-40 °C to +120 °C	+72 °C	+120 °C

Maximum short term base material temperature

Short-term elevated base material temperatures are those that occur over brief intervals, e.g., as a result of diurnal cycling.

Maximum long term base material temperature

Long-term elevated base material temperatures are roughly constant over significant periods of time.

Curing and working time

Temperature of the base material ^{a)}	HIT-HY 200-A V3		HIT-HY 200-R V3	
	Maximum working time	Minimum curing time	Maximum working time	Minimum curing time
T	t _{work}	t _{cure}	t _{work}	t _{cure}
- 10 °C to - 5 °C	1,5 h	7 h	3 h	20 h
> - 5 °C to 0 °C	50 min	4 h	1,5 h	8 h
> 0 °C to 5 °C	25 min	2 h	45 min	4 h
> 5 °C to 10 °C	15 min	75 min	30 min	2,5 h
> 10 °C to 20 °C	7 min	45 min	15 min	1,5 h
> 20 °C to 30 °C	4 min	30 min	9 min	1 h
> 30 °C to 40 °C	3 min	30 min	6 min	1 h

a) Installation of HIT-Z, HIT-Z-D TP only in range +5 °C to +40 °C

Setting details for HAS and HAS-U

Anchor size			M8	M10	M12	M16	M20	M24	M27	M30	
Nominal diameter of drill bit	d_0	[mm]	10	12	14	18	22	28	30	35	
Effective embedment depth (= drill hole depth h_0) ^{a)}	$h_{ef,min}$	[mm]	60	60	70	80	90	96	108	120	
	$h_{ef,max}$	[mm]	160	200	240	320	400	480	540	600	
Minimum thickness of concrete member	h_{min}	[mm]	$h_{ef} + 30 \text{ mm} \geq 100 \text{ mm}$			$h_{ef} + 2 d_0$					
Maximum diameter of clearance hole in the fixture	d_f	[mm]	9	12	14	18	22	26	30	33	
Maximum torque moment ^{b)}	T_{max}	[Nm]	10	20	40	80	150	200	270	300	
Minimum spacing	s_{min}	[mm]	40	50	60	75	90	115	120	140	
Minimum edge distance	c_{min}	[mm]	40	45	45	50	55	60	75	80	
Characteristic distances											
Spacing for splitting failure	$s_{cr,sp}$	[mm]	$2 C_{cr,sp}$								
Edge distance for splitting failure ^{c)}	$c_{cr,sp}$	[mm]	$1,0 \cdot h_{ef}$ for $h/h_{ef} \geq 2,00$								
			$4,6 \cdot h_{ef} - 1,8 \cdot h$ for $2,0 > h/h_{ef} > 1,3$								
			$2,26 \cdot h_{ef}$ for $h/h_{ef} \leq 1,3$								
Spacing for concrete cone failure ^{d)}	$s_{cr,N}$	[mm]	$2 C_{cr,N}$								
Edge distance for concrete cone failure ^{d)}	$c_{cr,N}$	[mm]	$1,5 h_{ef}$								

For spacing (edge distance) smaller than characteristic spacing (characteristic edge distance) the design loads must be reduced.

a) $h_{ef,min} \leq h_{ef} \leq h_{ef,max}$ (h_{ef} : embedment depth)

b) Maximum torque moment to avoid splitting failure during installation with minimum spacing and edge distance

c) h : base material thickness ($h \geq h_{min}$)

d) The characteristic edge distance for concrete cone failure depends on the embedment depth h_{ef} and the design bond resistance. The simplified formula given in this table is on the safe side.

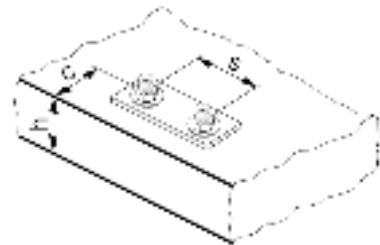
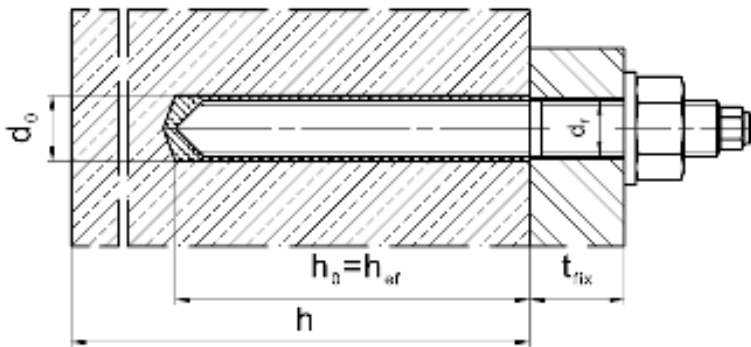

Setting details for HIS-N

Anchor size		M8	M10	M12	M16	M20
Nominal diameter of drill bit	d_0 [mm]	14	18	22	28	32
Diameter of element	d [mm]	12,5	16,5	20,5	25,4	27,6
Effective embedment depth (=drill hole depth)	$h_{ef} = h_0$ [mm]	90	110	125	170	205
Minimum thickness of concrete member	h_{min} [mm]	120	150	170	230	270
Diameter of clearance hole in the fixture	d_f [mm]	9	12	14	18	22
Thread engagement length; min - max	h_s [mm]	8-20	10-25	12-30	16-40	20-50
Maximum torque moment ^{a)}	T_{max} [Nm]	10	20	40	80	150
Minimum spacing	s_{min} [mm]	60	75	90	115	130
Minimum edge distance	c_{min} [mm]	40	45	55	65	90
Characteristic distances						
Spacing for splitting failure	$s_{cr,sp}$ [mm]	$2 c_{cr,sp}$				
Edge distance for splitting failure ^{b)}	$c_{cr,sp}$ [mm]	$1,0 \cdot h_{ef}$ for $h/h_{ef} \geq 2,00$				
		$4,6 \cdot h_{ef} - 1,8 \cdot h$ for $2,0 > h/h_{ef} > 1,3$				
		$2,26 \cdot h_{ef}$ for $h/h_{ef} \leq 1,3$				
Spacing for concrete cone failure ^{c)}	$s_{cr,N}$ [mm]	$2 c_{cr,N}$				
Edge distance for concrete cone failure ^{c)}	$c_{cr,N}$ [mm]	$1,5 h_{ef}$				

For spacing (edge distance) smaller than characteristic spacing (characteristic edge distance) the design loads must be reduced.

a) Max. recommended torque moment to avoid splitting failure during Installation with minimum spacing and edge distance

b) h : base material thickness ($h \geq h_{min}$)

c) The characteristic edge distance for concrete cone failure depends on the embedment depth h_{ef} and the design bond resistance. The simplified formula given in this table is on the safe side.

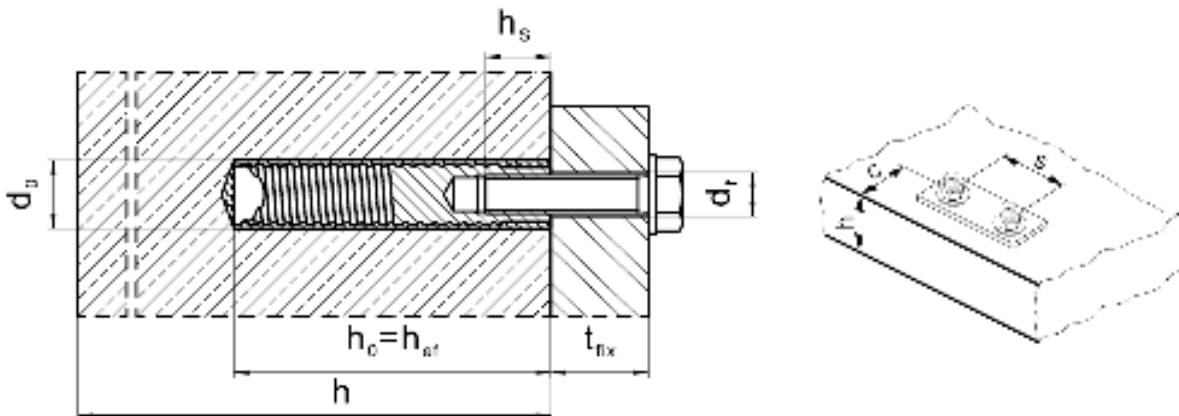

Setting details rebar

Anchor size		Ø8	Ø10	Ø12	Ø14	Ø16	Ø20	Ø25	Ø26	Ø28	Ø30	Ø32
Nominal diameter of drill bit	d_0 [mm]	10 / 12 ^{a)}	12 / 14 ^{a)}	14 / 16 ^{a)}	18	20	25	32	32	35	37	40
Effective embedment depth min. and max. (=drill hole depth h_0) ^{b)}	h_{ef} [mm]	60	60	70	75	80	90	100	104	112	120	128
	[mm]	160	200	240	280	320	400	500	520	560	600	640
Minimum thickness of concrete member ^{c)}	h_{min} [mm]	$h_{ef} + 30 \text{ mm}$ $\geq 100 \text{ mm}$			$h_{ef} + 2 d_0$							
	[mm]											
Minimum spacing	s_{min} [mm]	40	50	60	70	80	100	125	130	140	150	160
Minimum edge distance	c_{min} [mm]	40	45	45	50	50	65	70	75	75	80	80
Characteristic distances												
Spacing for splitting failure	$s_{cr,sp}$ [mm]	$2 c_{cr,sp}$										
Edge distance for splitting failure ^{c)}	$c_{cr,sp}$ [mm]	$1,0 \cdot h_{ef}$		for $h / h_{ef} \geq 2,0$								
		$4,6 h_{ef} - 1,8 h$		for $2,0 > h / h_{ef} > 1,3$								
		$2,26 h_{ef}$		for $h / h_{ef} \leq 1,3$								
Spacing for concrete cone failure	$s_{cr,N}$ [mm]	$2 c_{cr,N}$										
Edge distance for concrete cone failure ^{d)}	$c_{cr,N}$ [mm]	$1,5 h_{ef}$										

For spacing (edge distance) smaller than characteristic spacing (characteristic edge distance) the design loads must be reduced,

- a) Both given values for drill bit diameter can be used
- b) $h_{ef,min} \leq h_{ef} \leq h_{ef,max}$ (h_{ef} : embedment depth)
- c) h : base material thickness ($h \geq h_{min}$)
- d) The characteristic edge distance for concrete cone failure depends on the embedment depth h_{ef} and the design bond resistance, The simplified formula given in this table is on the safe side.

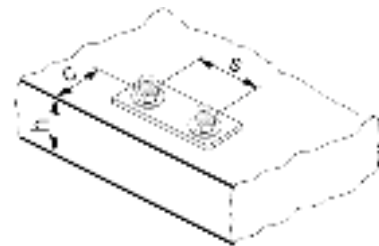
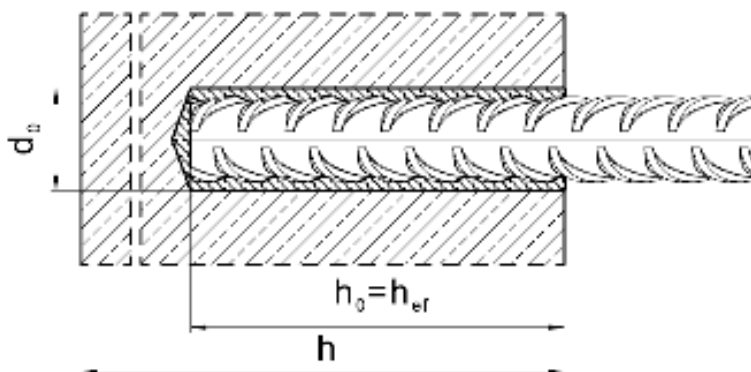

Setting details for HIT-Z, HIT-Z-F and HIT-Z-R

Anchor size			M8	M10	M12	M16	M20
Nominal diameter of drill bit	d_0	[mm]	10	12	14	18	22
Length of anchor	min l	[mm]	80	95	105	155	215
	max l	[mm]	120	160	196	420	450
Effective embedment depth ^{a)}	$h_{ef,min}$	[mm]	60	60	60	96	100
	$h_{ef,max}$	[mm]	100	120	144	192	220
Borehole condition 1 Min. base material thickness	h_{min}	[mm]	$h_{ef} + 60$ mm			$h_{ef} + 100$ mm	
Borehole condition 2 Min. base material thickness	h_{min}	[mm]	$h_{ef} + 30$ mm ≥ 100 mm			$h_{ef} + 45$ mm ≥ 45 mm	
Maximum depth of drill hole	h_0	[mm]	$h - 30$ mm			$h - 2 d_0$	
Diameter of clearance hole in the fixture	pre setting d_f	[mm]	9	12	14	18	22
	through setting d_f	[mm]	11	14	16	20	24
Maximum fixture thickness	t_{fix}	[mm]	48	87	120	303	326
Maximum fixture thickness with seismic filling set	t_{fix}	[mm]	41	79	111	292	314
Installation torque moment ^{b)}	HIT-Z, HIT-Z-F T_{inst}	[Nm]	10	25	40	80	150
	HIT-Z-R T_{inst}	[Nm]	30	55	75	155	215
Characteristic distances							
Spacing for splitting failure	$S_{cr,sp}$	[mm]	$2 C_{cr,sp}$				
Edge distance for splitting failure ^{c)}	$C_{cr,sp}$	[mm]	$1,5 \cdot h_{ef}$		for $h / h_{ef} \geq 2,35$		
			$6,2 h_{nom} - 2,0 h$		for $2,35 > h / h_{ef} > 1,35$		
			$3,5 h_{ef}$		for $h / h_{ef} \leq 1,35$		
Spacing for concrete cone failure	$S_{cr,N}$	[mm]	$2 C_{cr,N}$				
Edge distance concrete cone failure	$C_{cr,N}$	[mm]	$1,5 h_{ef}$				

For spacing (edge distance) smaller than characteristic spacing (characteristic edge distance) the design loads must be reduced.

a) $h_{ef,min} \leq h_{ef} \leq h_{ef,max}$ (h_{ef} : effective embedment depth).

b) Recommended torque moment to avoid splitting failure during installation with minimum spacing and edge distance.

c) h : base material thickness ($h \geq h_{min}$).

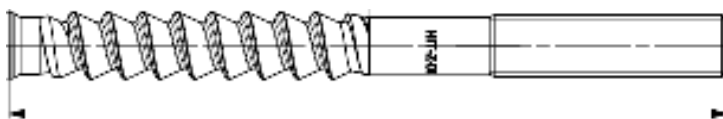

Pre-setting:
Install anchor before positioning fixture

Through-setting:
Install anchor through positioned fixture

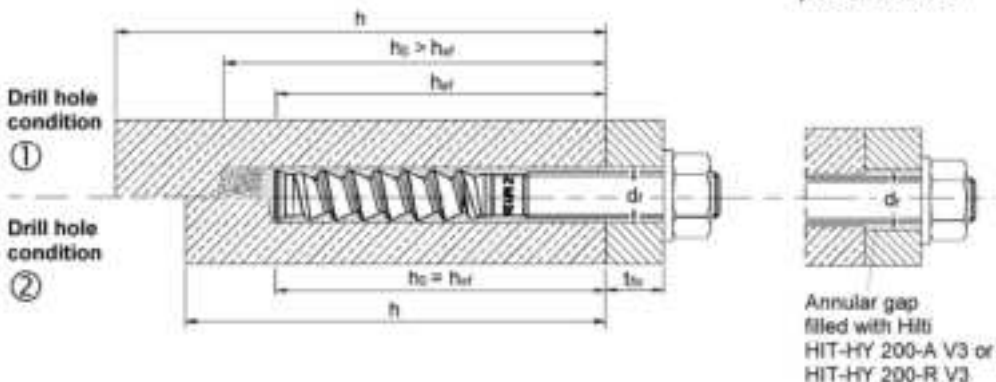

Minimum edge distance and spacing for HIT-Z

Pre-calculated distances are given in the following tables.

Best case minimum edge distance and spacing with required member thickness and embedment depth

Member thickness $h \geq h_{nom} + 1,5 \cdot c$

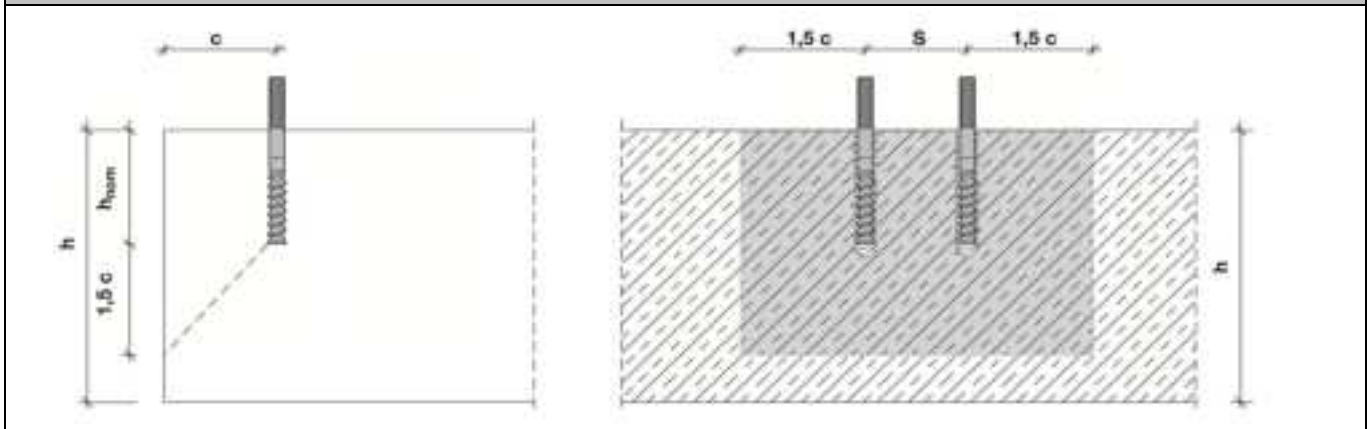

Anchor size		M8	M10	M12	M16	M20
Cracked concrete						
Member thickness	$h \geq$ [mm]	140	200	240	300	370
Embedment depth	$h_{nom} \geq$ [mm]	80	120	150	200	220
Minimum spacing and corresponding edge distance	s_{min} [mm]	40	50	60	80	100
	$c \geq$ [mm]	40	55	65	80	100
Minimum edge distance and corresponding spacing	$c_{min} =$ [mm]	40	50	60	80	100
	$s \geq$ [mm]	40	60	65	80	100
Uncracked concrete						
Member thickness	$h \geq$ [mm]	140	230	270	340	410
Embedment depth	$h_{nom} \geq$ [mm]	80	120	150	200	220
Minimum spacing and corresponding edge distance	s_{min} [mm]	40	50	60	80	100
	$c \geq$ [mm]	40	70	80	100	130
Minimum edge distance and corresponding spacing	c_{min} [mm]	40	50	60	80	100
	$s \geq$ [mm]	40	145	160	160	235

Best case minimum member thickness and embedment depth with required minimum edge distance and spacing (borehole condition 1)

Member thickness $h \leq h_{nom} + 1,5 \cdot c$

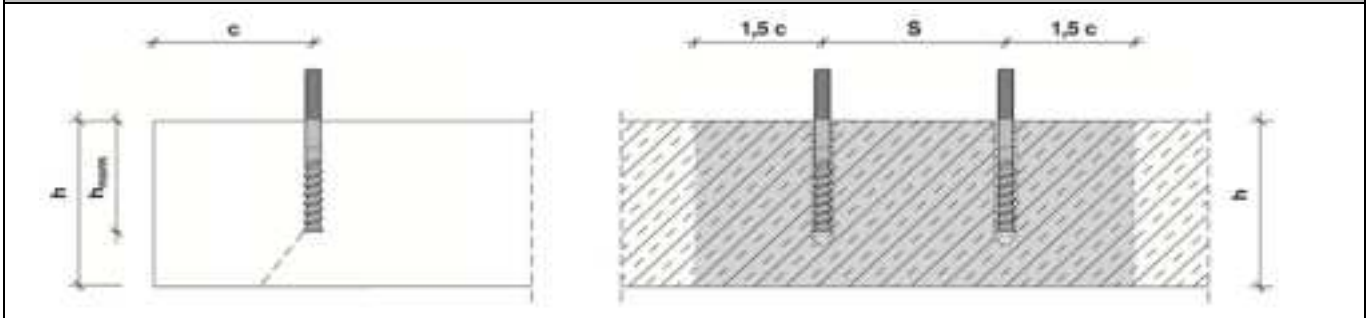

Anchor size			M8	M10	M12	M16	M20
Cracked concrete							
Member thickness	$h \geq$	[mm]	120	120	120	196	200
Embedment depth	$h_{nom} \geq$	[mm]	60	60	60	96	100
Minimum spacing and corresponding edge distance	s_{min}	[mm]	40	50	60	80	100
	$c \geq$	[mm]	40	100	140	135	215
Minimum edge distance and corresponding spacing	$c_{min} =$	[mm]	40	60	90	80	125
	$s \geq$	[mm]	40	160	220	235	365
Uncracked concrete							
Member thickness	$h \geq$	[mm]	120	120	120	196	200
Embedment depth	$h_{nom} \geq$	[mm]	60	60	60	96	100
Minimum spacing and corresponding edge distance	s_{min}	[mm]	40	50	60	80	100
	$c \geq$	[mm]	50	145	200	190	300
Minimum edge distance and Corresponding spacing	c_{min}	[mm]	40	80	115	110	165
	$s \geq$	[mm]	65	240	330	310	495

Minimum edge distance and spacing – Explanation

Minimum edge and spacing geometrical requirements are determined by testing the installation conditions in which two anchors with a given spacing can be set close to an edge without forming a crack in the concrete due to tightening torque.

The HIT-Z boundary conditions for edge and spacing geometry can be found in the tables. If the embedment depth and slab thickness are equal to or greater than the values in the table, then the edge and spacing values may be utilized.

PROFIS Engineering software is programmed to calculate the referenced equations in order to determine the optimized related minimum edge and spacing based on the following variables:

<u>Cracked or uncracked concrete</u>	For cracked concrete it is assumed that a reinforcement is present which limits the crack width to 0,3 mm, allowing smaller values for minimum edge distance and minimum spacing
<u>Anchor diameter</u>	For smaller anchor diameter a smaller installation torque is required, allowing smaller values for minimum edge distance and minimum spacing
<u>Slab thickness and embedment depth</u>	Increasing these values allows smaller values for minimum edge distance and minimum spacing

Setting details for HAS-D

Anchor size			M12	M16	M20	
Nominal diameter of drill bit	d_0	[mm]	14	18	24	
Effective anchorage depth	h_{ef}	[mm]	100	125	170	
Minimum drill hole depth	h_0	[mm]	105	133	180	
Minimum base material thickness	h_{min}	[mm]	130	160 ¹⁾ / 170	220 ¹⁾ / 230	
Diameter of clearance hole in the fixture	pre setting	d_f	[mm]	14	18	24
	through setting	d_f	[mm]	16	20	26
Fixture thickness under fatigue loading	$t_{fix,min}$	[mm]	12	16	20	
	$t_{fix,max}$	[mm]	200			
Installation torque moment	T_{inst}	[Nm]	30	50	80	
Uncracked concrete	Minimum spacing	s_{min}	[mm]	80 55	60	80
	Minimum edge distance	c_{min}	[mm]	55 80	60	80
Cracked concrete	Minimum spacing	s_{min}	[mm]	50	60	80
	Minimum edge distance	c_{min}	[mm]	50	60	80
Characteristic distances						
Spacing for splitting failure	$s_{cr,sp}$	[mm]	600	750	884	
Edge distance for splitting failure	$c_{cr,sp}$	[mm]	300	375	442	
Spacing for concrete cone failure	$s_{cr,N}$	[mm]	2 $c_{cr,N}$			
Edge distance concrete cone failure	$c_{cr,N}$	[mm]	1,5 h_{ef}			

1) The reverse side of the concrete member shall have no break-through after drilling.

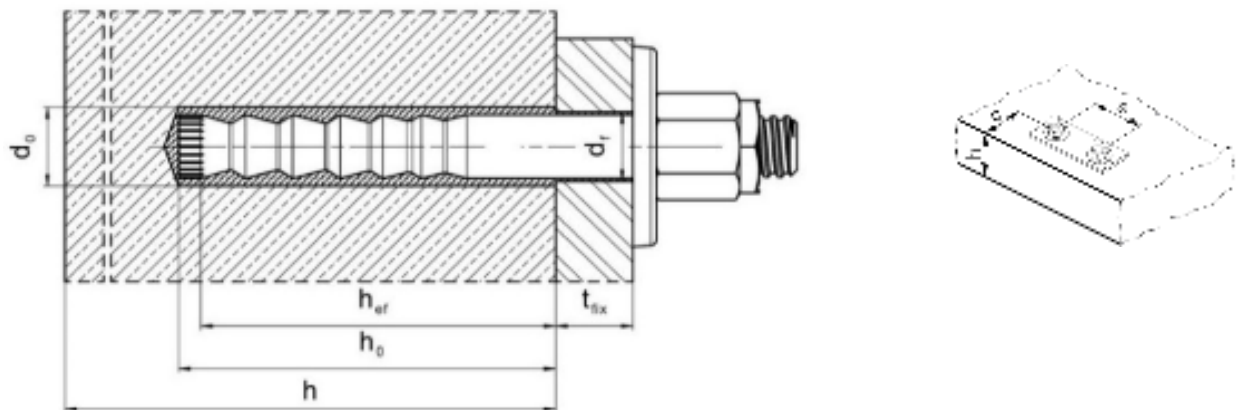

Drilling and Installation equipment

For detailed setting information on installation see instructions for use given with the product.

Rotary Hammers (Corded and Cordless)		TE 2 - TE 70
Diamond Coring Machines		DD EC-1, DD 100 ... DD 160
Dispenser		HDE HDM
Other tools		Blow out pump, Compressed air gun, Set of cleaning brushes
		Hammer drill bit TE-CX, TE-YX, TE-C, TE-Y
		Hollow drill bit TE-CD, TE-YD
		Diamond core bit SP-L, SP-HX, SP-H, P-U
		Roughening tools TE-YRT
	Piston plug	