

Dual RX Link Power HUB
DLPH-2

Instruction Manual

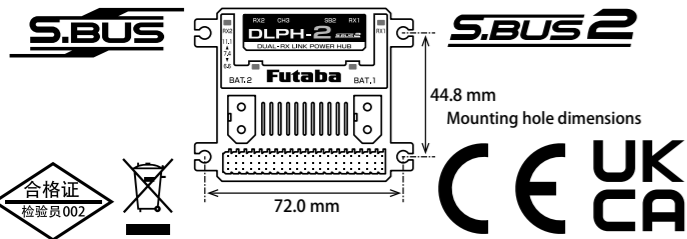

Thank you for purchasing the DLPH-2. Before using your new DLPH-2, please read this manual thoroughly and use the DLPH-2 properly and safely. After reading this manual, store it in a safe place.

Use : Two receivers and two batteries communication switching device

Size : 62.8 × 62.4 × 18.1 mm
(2.47 × 2.46 × 0.71 in)

Weight : 50 g (1.76 oz)

FET rated : Always 60 A / 2 pcs

Operating voltage : DC6.4 V to 13.0 V

Accessories: ● Switch ● Mini screwdriver ● Flange damper

● Eyelet ● Wood screw ● Receiver connection cord x 3
(One cord is used in airplane gyro mode)

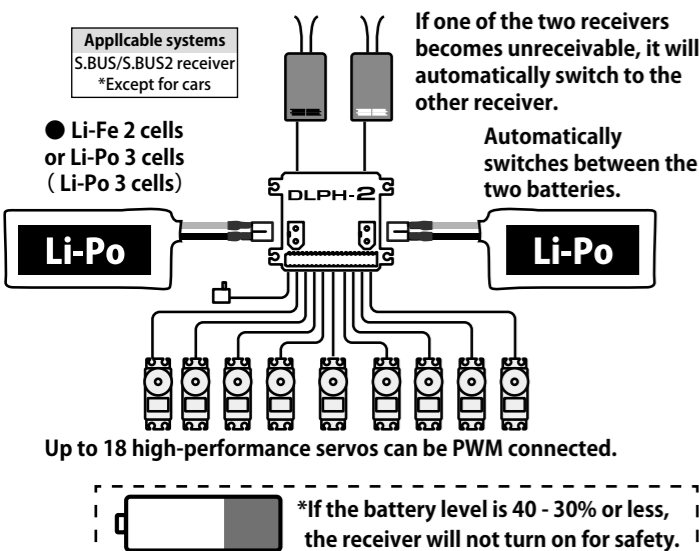
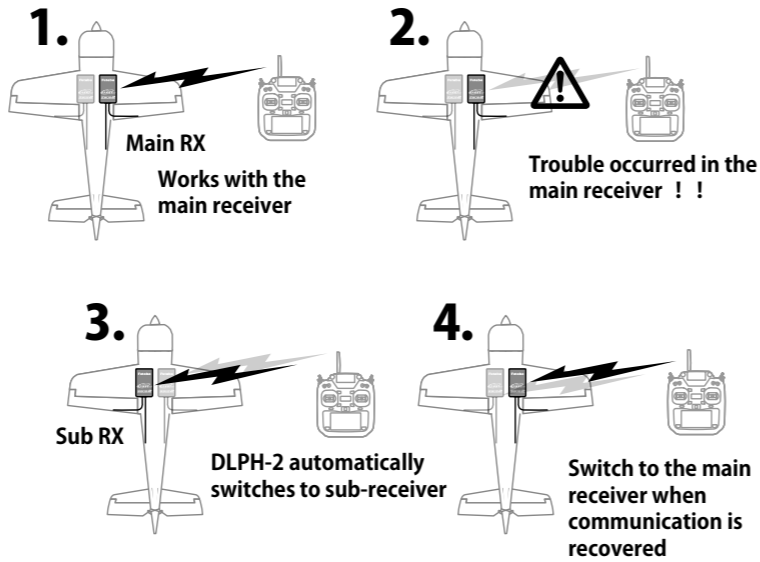

Receiver Link

1. Install two receivers on the aircraft as shown in the wiring diagram on the next page.
2. Link the two receivers using the dual receiver feature of the transmitter.

Transmitter in link mode
For FASSTest 18CH Select dual mode and link primary

Transmitter in link mode
For FASSTest 18CH Select dual mode and link secondary

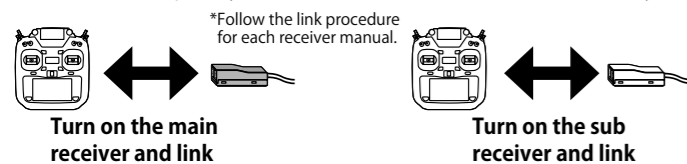

About telemetry system

When using the dual receiver function

- The telemetry function of the main receiver can be used
- Sub-receiver telemetry function is not available

Other than dual receiver function

- Telemetry not available
- Set telemetry to INH (disabled)

Battery F/S

- For receivers that can set the battery F / S, set the battery F / S to 4.8 V or less or OFF.
- Also, make sure that the battery F / S of the two receivers have the same settings.

Since the output voltage from DLPH-2 is 5 V, if the battery F / S is set to 5 V or higher, the battery F / S will always operate.

Fail-safe

- If a receiver error occurs, priority is given to the output of RX1 (main receiver) for F/S data.

Precautions

- WARNING**
Failure to follow these safety precautions may result in severe injury to yourself and others.
- ❗ **In order to prevent any short circuits, please observe the polarity of all connections.**
 - ❗ **Ensure that the unit is connected properly to the receiver.**
■ If the connector is disconnected during flight, it becomes inoperable.
 - ❗ **Ensure that the unit is mounted in an area that will eliminate exposure to fuel and water.**
■ As with any electronic components, proper precautions are urged to prolong the life and increase the performance of the unit.
 - ❗ **Allow a slight amount of slack in the unit cables and fasten them at a suitable location to prevent any damage from vibration during flight.**
 - ❗ **Be sure to link the two receivers with the transmitter.**
■ It will not work unless the two receivers are linked. After startup, even if the link on one side is disconnected, the other side will continue to operate normally.
 - ❗ **Used in a set of Futaba S.BUS / S.BUS2 systems.**
 - ❗ **Do not supply receiver power from the ESC. When using the receiver power supply type ESC, remove the red (+) cord of the 3ch wiring from the ESC so that the power is not supplied from the ESC.**
■ Use a dedicated battery to power the receiver / servo.
 - ❗ **Do not connect the servo and telemetry sensor directly to the receiver.**
■ Large current flows through the Rx port of DLPH-2 and is damaged.
 - ❗ **Do not connect a high voltage battery beyond the specifications of the servo used.**
■ There is a risk of explosion, fire and damage.
 - ❗ **Do not use more than 60A for a moment.**
■ Reference: Although it depends on the servo used and flight style, acro flight with 15 HPS servos has been confirmed.
 - ❗ **To ensure that the DLPH-2 is functioning as desired, please test accordingly.**
■ Do not fly until inspection is complete.
 - ❗ **Before the flight, disconnect the wiring of the main receiver from the DLPH-2 that is operating normally, and check if the sub receiver alone can control it.**
■ Check if the DLPH-2 switches.
 - ❗ **Do not use the DLPH-2 with anything other than an R/C model.**

How to Use

Wiring

- ⊘ Do not supply receiver power from the ESC. When using the receiver power supply type ESC, remove the red (+) cord of the 3ch wiring from the ESC so that the power is not supplied from the ESC.
- Use a dedicated battery to power the receiver / servo.

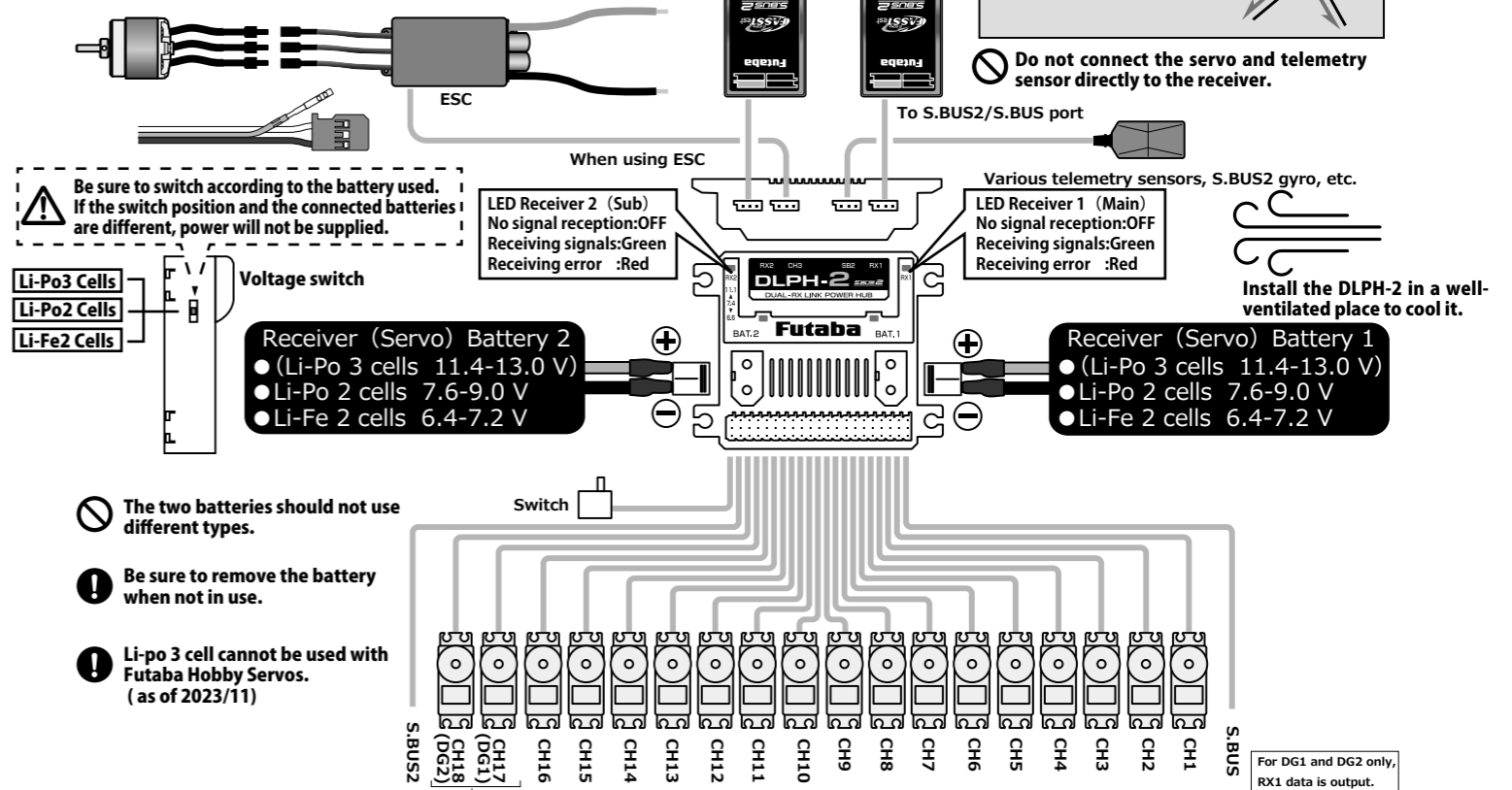

- ⊘ The two batteries should not use different types.
- ❗ Be sure to remove the battery when not in use.
- ❗ Li-po 3 cell cannot be used with Futaba Hobby Servos. (as of 2023/11)

Dual battery system

Two power supply batteries can be connected to the DLPH-2. Power is supplied from the battery with the highest voltage. The operating time is the total time of the 2 batteries. For example, even if the voltage of one battery drops, power can be supplied from the other battery. Even one battery can be used, but safer flight is possible if 2 batteries are used.

This receiver employs an electronic switching (current is controlled by an FET circuit) system. When the exclusive switch is set to ON or is pulled, the power is turned on. Switches other than the exclusive switch cannot be used. In addition, since a very small current flows even when the power is off, always disconnect the battery from the connector when the receiver is not in use.

One or 2 batteries can be connected. When 2 batteries are connected, the battery with the highest voltage is used. When only one battery is connected, always insulate the unused connector. The battery can be connected to either side.

Use batteries with sufficient capacity for the specifications and number of servo motors to be used.

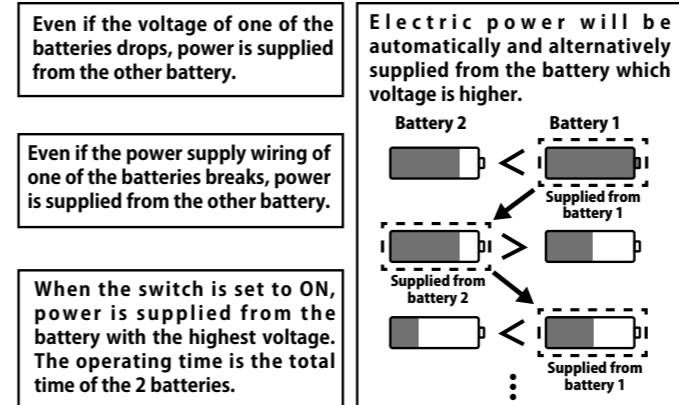

Battery LED

The battery LED on the side being used lights up. It turns off when each becomes 6 V or less.

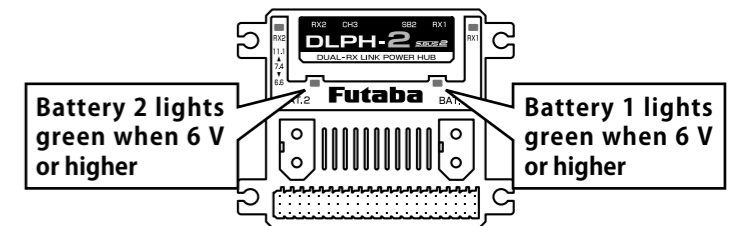

Telemetry function (voltage display)

The DLPH-2 is equipped with a telemetry sensor function. The receiver voltage displayed on the transmitter home screen is only a constant value. The voltages of battery 1 and battery 2 should be monitored by telemetry voltage.

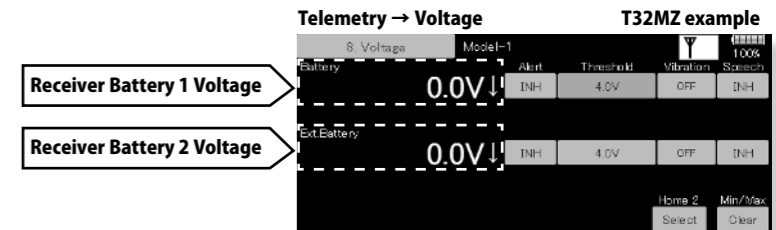

DLPH-2 uses two continuous slots. Please note that the proper default start slot for this accessory is number 6. When setup-changing or adding, it is the following numbers that are made to a start slot.

1,2,3,4,5,6,8,9,10,11,12,13,14,16,17,18,19,20,21,22,24,25,26,27,28,29,30

By connecting the transmitter and SB2 port, it is possible to register to the transmitter and change the start slot. In that case, it is necessary to connect the battery to DLPH-2 and supply power. Information on how to change the slot assignment is included in the transmitter's manual.

FUTABA CORPORATION

Hobby Radio Control Business Center Sales & Marketing Department
1080 Yabutsuka, Chosei-mura, Chosei-gun, Chiba-ken, 299-4395, Japan
TEL: +81-475-32-6051, FAX: +81-475-32-2915

Connection example for each application

Single receiver

☆☆ Single receivermode

Connect the DLPH-2 to the compatible transmitter's S.I/F connector and change the mode.

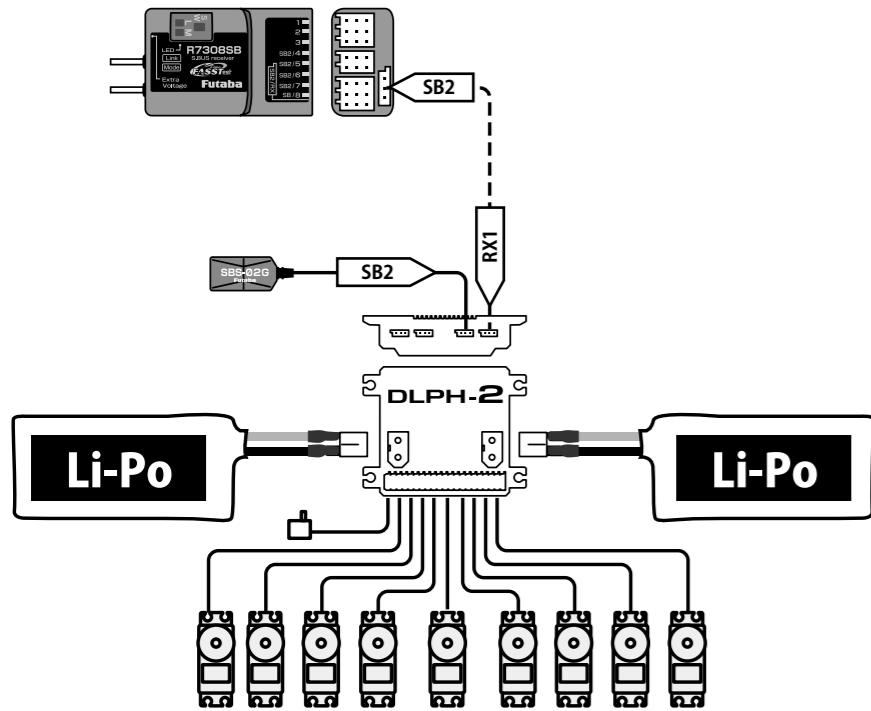

This is an example of using one receiver and two batteries. Deal with battery problems. Since the dual RX function is not movable, it does not correspond to any reception troubles.

Single receiver+Airplane gyro GYA553

☆☆ Single receivermode

Connect the DLPH-2 to the compatible transmitter's S.I/F connector and change the mode.

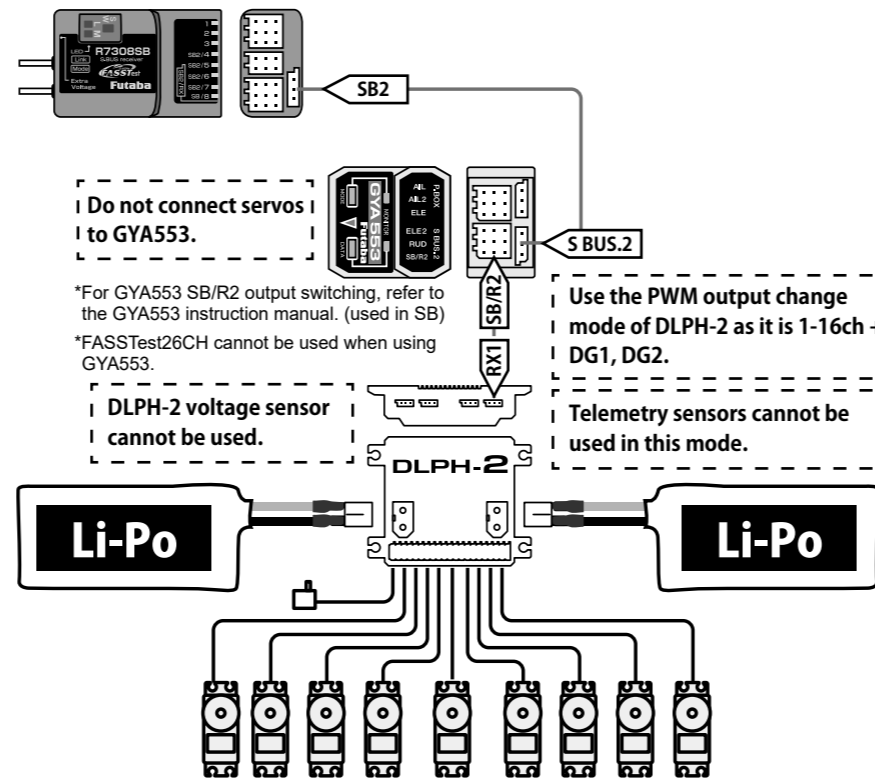

Here is an example using one receiver, two batteries, and an airplane gyro GYA553. Deal with battery problems. Since the dual RX function is not movable, it does not correspond to any reception troubles.

Dual receiver+Airplane gyro GYA553

☆☆☆☆ Airplane gyro mode

Do not connect servos to GYA553.

Connect the DLPH-2 to the compatible transmitter's S.I/F connector and change the mode.

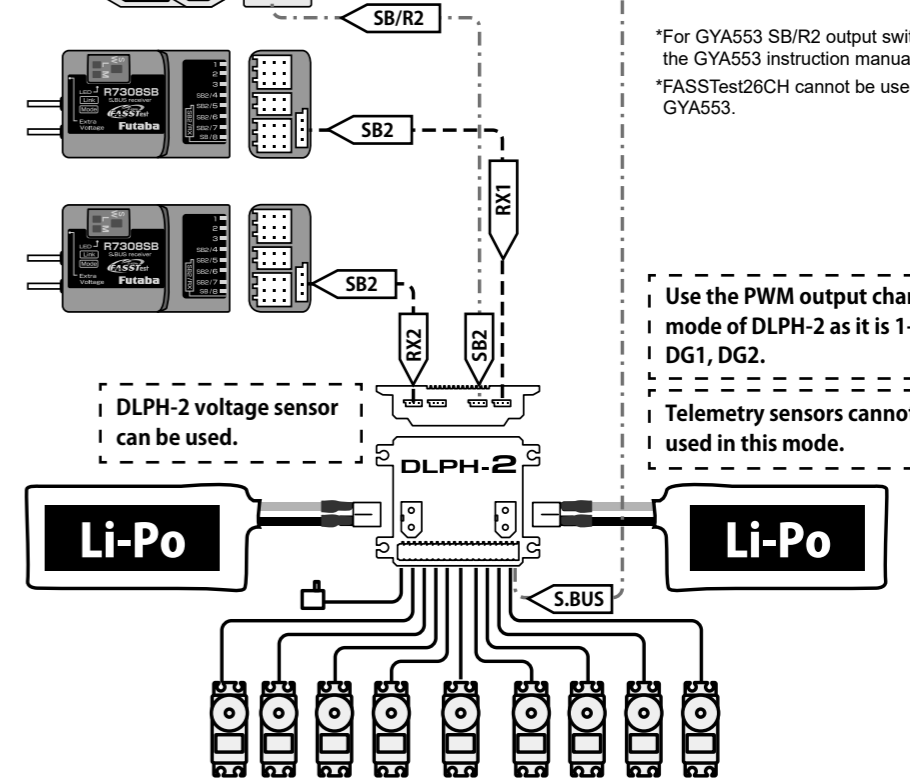

Here is an example using 2 receivers, 2 batteries and an airplane gyro GYA553. Deal with battery problems. The dual RX function is activated to deal with any possible reception troubles.

DLPH-2 mode change

The mode change of DLPH-2 is done by connecting to the S.I/F connector of the compatible transmitter. The setting method is described in the update manual of the compatible transmitter.

Functions that can be changed with compatible transmitters

1. Change setting mode

- Dual RX mode (default setting)
- **Single receivermode**
- **Airplane gyro mode**

2. PWM output change

- 1-16ch+DG1,DG2 (default setting)
- 17-24ch+DG1,DG2

This PWM port can be changed from 1-16CH+DG1,DG2 (default setting) to 17-24CH+DG1,DG2.

*9CH~16CH ports cannot be used.

When using single receiver + Airplane gyro GYA553 or airplane gyro mode, use 1-16ch + DG1, DG2 as they are.

*17-24ch+DG1,DG2
CH3→CH19



Battery LED display at startup

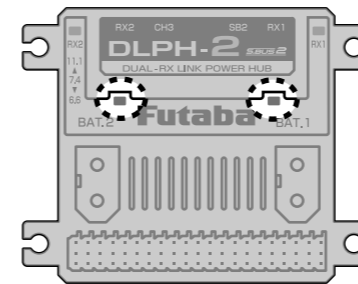

The battery LED display at startup informs you of the current status of the DLPH-2.

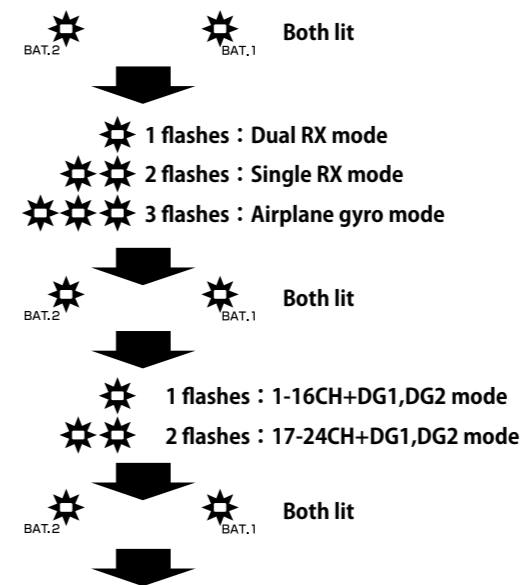

During this time, both LEDs will be lit regardless of battery voltage or number of connections.

To monitor the battery, check the LED display after this.

Battery LED

The battery LED on the side being used lights up. It turns off when each becomes 6 V or less.

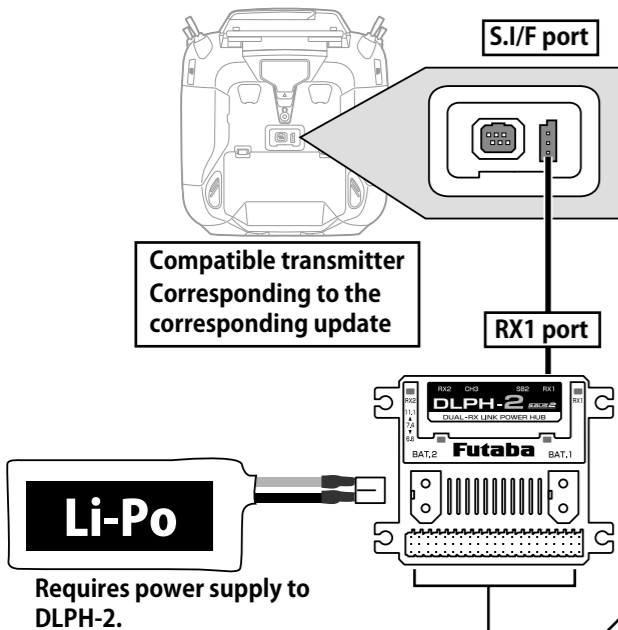

Requires power supply to DLPH-2.