

Flyable Active Subwoofer



MAIN APPLICATIONS

Permanent installations in:

- Theatres, Concert Halls, Clubs, Places of Worship, Conference Rooms, Indoor Sports, Arenas & Stadiums

Sound reinforcement for live events:

- Touring, Bands, Orchestras

MAIN FEATURES

- Compact Hybrid band pass cardioid-arrayable subwoofer. Hybrid configuration permit to obtain extension and speed of vented with high SPL and acoustic filtering of band pass
- 18" (460mm) custom B&C neodymium magnet high excursion woofer with 3.5" (88mm) voice coil
- Class D amplifier 1600WRMS with switch mode power supply
- Frequency Response from 33Hz @-6dB
- DANTE audio streaming with 24bit at 48-96KHz on TCP/IP network
- Network interface TCP/IP - AES70 compatible
- OLED DISPLAY and ENCODER with PUSH for easy onboard control
- EtherCon RJ45 input and output for daisy-chain
- 5/8" (15mm) birch plywood enclosure, scratch resistant black paint
- 4 aluminum handles and heavy duty metal grille with synthetic protection cloth
- M20 top mount stand socket
- Optional 4 swivel-mount 4" (100mm) casters
- Suspension hardware fully compatible with MUSE210LND allowing the enclosure to be suspended front or rear-firing for easy cardioid configurations
- Very large area laminar-flow port to ensure no power compression and very low port turbulence
- Low frequency extension cabinet for the MUSE210LND line array for flying or ground stacked configurations
- It's possible to order Muse 118FSCA model that's the version already factory preconfigured as rear facing for cardioid applications

DESCRIPTION

MUSE 118FSND is an innovative powered subwoofer designed to create suspended clusters with omnidirectional or cardioid directivity, guaranteeing the same excellent aesthetic result. Equipped with B&C 18" (460mm) neodymium woofer with 3.5" (88mm) voice coil and 1600W RMS amplifier capable of 140dB SPL, MUSE 118FSND is ideal to be suspended together with MUSE 210LND powered line array or in a separate cluster. The cardioid configuration requires that some subwoofers face rearwards from the audience to acoustically cancel the sound pressure behind the cluster. The particular engineering of the enclosure that allows it to be suspended facing forward or backward, allowing the end user to reverse the front-back position of the grid and amplifier. All subwoofers will thus have the front grille regardless of the real orientation of the enclosures. Cardioid configuration allows a reduction of the SPL on the back of the array by over 15dB. MUSE 118FSCND model, identical to the 118FSND model, comes preconfigured at the factory for cardioid use. Innovative hybrid band-pass acoustic configuration designed to minimize the volume ensuring excellent frequency extension high SPL. The enclosure is built with 15mm birch plywood with four die-cast aluminum handles, the integrated hardware into the enclosure allows suspension of 8 elements with a safety factor of 10:1. The summit of the entire project is the new 1600W RMS amplification module with built-in TCP / IP network interface. Based on AES70 standard (OCA Alliance), it communicates with FBT's 'INFINITO management suite' remote control software and receives 24bit 48-96Khz digital audio streaming from all devices compatible with 'DANTE' standard. The module is housed in an aluminum chassis with intelligent forced ventilation and is equipped with an OLED display with encoder for parameter setting. A high-brightness blue front LED allows remote identification of the device also in daylight.

TECHNICAL SPECIFICATIONS

GENERAL

Code	118 FSND	44259
	118 FSCND	44260
Configuration	way	Hybrid bandpass
Low frequency woofer	inch	18 - 3.5 coil neodymium
High frequency driver	inch	---

ACOUSTIC SPECIFICATIONS

Frequency response (@-6dB)	Hz	33 - preset dependant
MAX SPL (cont/peak)	dB	136 / 140 half-space
Dispersion	H° x V°	Omnidirectional

INPUTS & OUTPUTS

Power supply connectors		PowerCon IN/OUT
Input connectors		2 x XLR IN/OUT
Input / Output NET		NET IN/OUT (EtherCon)

POWER SUPPLY

AC power requirement	W	600
Power cord	mt	5
	ft	16.4

AMPLIFIER

Buit-in amplifier MAX (LF/HF)	W	1600
Buit-in amplifier MAX peak (LF/HF)	W	3200
Input impedance	Ohm	22k

MECHANICAL SPECIFICATIONS

Material	Cabinet	0.59" Birch plywood
	Grille	Heavy-duty metal
Net dimensions (WxHxD)	mm	652 x 500 x 750
	inch	25.66 x 19.68 x 29.52
Transport dimensions (WxHxD) with pallet	mm	810 x 660 x 765
	inch	31.89 x 25.98 x 30.12
Net weight	kg	67
	lb	147.71
Transport weight with pallet	kg	77
	lb	169.76

DIMENSIONAL DRAWINGS

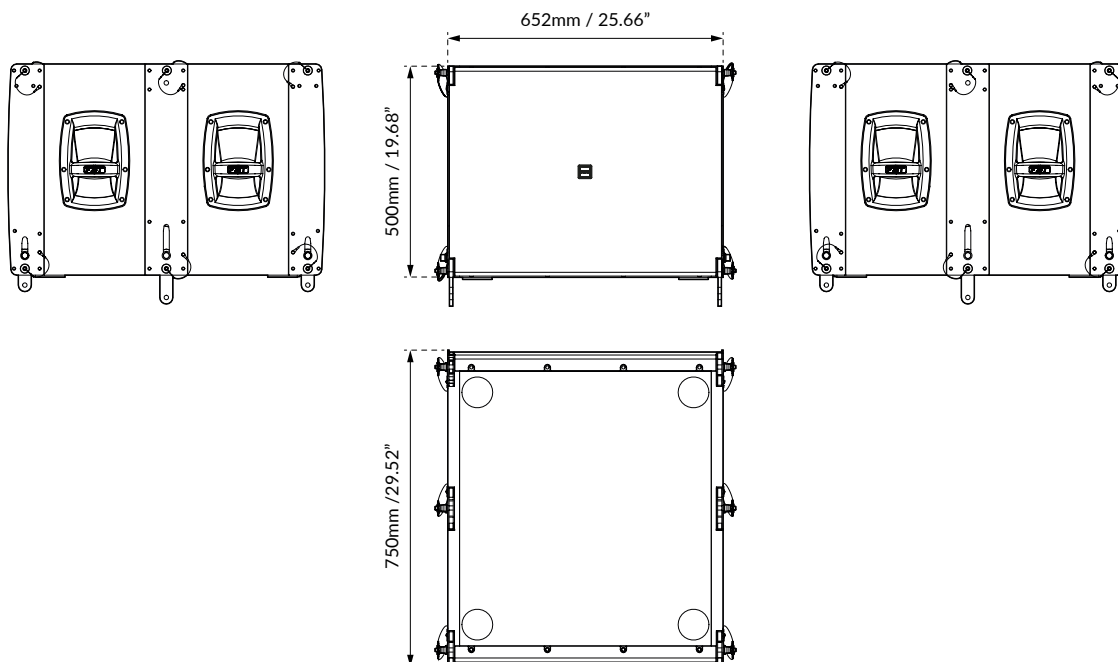

CONTROL PANEL

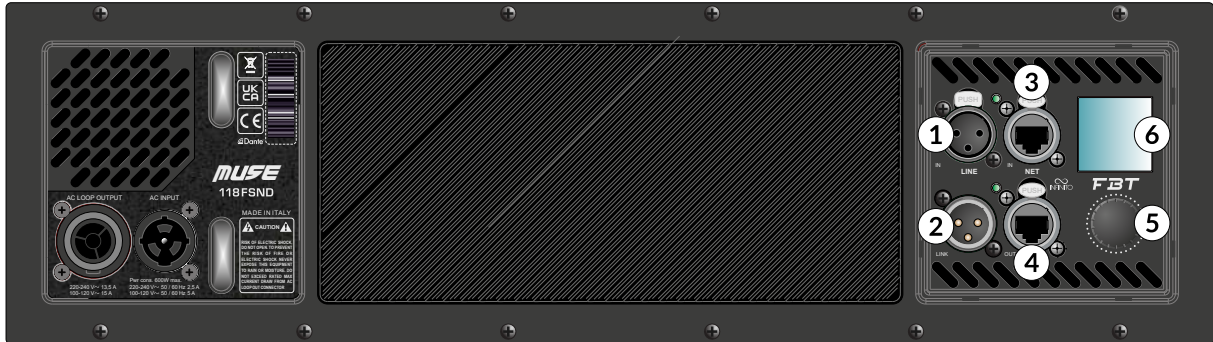

- 1. XLR input
- 2. XLR link output
- 3. Port compatible with EtherCON/RJ45 connectors used for Ethernet network input for remote control and monitoring via INFINITO MANAGEMENT SOFTWARE
- 4. Port compatible with etherCON/RJ45 connectors used for the daisy chain output of the INFINITO SOFTWARE MANAGEMENT remote control and monitoring Ethernet network
- 5. General digital volume to control the level of signal. Press to enter the DSP menu and turn the knob to identify and select the parameters
- 6. Displaying of menus and DSP settings

SOFTWARE INFINITO



INFINITO is a real revolution in the FBT world that enhance the user experience in a new level of performance and simplicity! It's a Windows software platform totally developed in house by FBT R&D team that offers real time monitoring of the internal sensors and status of connected devices, fast IN/OUT Vu-meters, controls of all the parameters, group management, warnings readout. More than 100 devices can be connected on the same TCP/IP network with the added convenience of auto IP address assignment.

Download it from our website: www.fbt.it

ACCESSORIES

MS-F 210

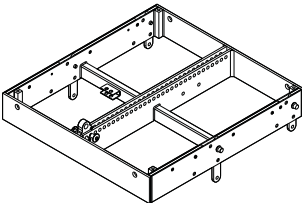

Flying Bar
Code: 38834

686 x 100 x 652mm
27 x 3.93 x 25.66inch
30 kg / 66.13 lb

KBW-1004S

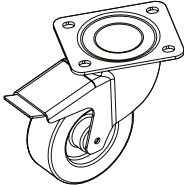

4 Wheels Kit with Brake
Code: 25197

ø100mm
ø4inch
4 kg / 8.81lb