

Euromaid

User Manual

183L Upright Freezer

EUFR183W



Content

1.Parts and Features	page 2
2.Instructions for Installation	page 3
3.Cautions for Safety	page 4
4.Important Safeguards	page 5~7
5.Operation	page 8
6.Cleaning and Maintenance	page 9
7. Reversing the Door	page 10~11
8.Troubleshooting	page 12
9.Warnings and Important Disposal Instructions	page 13
10.R600a Refrigerant	page 14
11.Product Information	page 14
12.Warranty	page 16

Parts and Features :

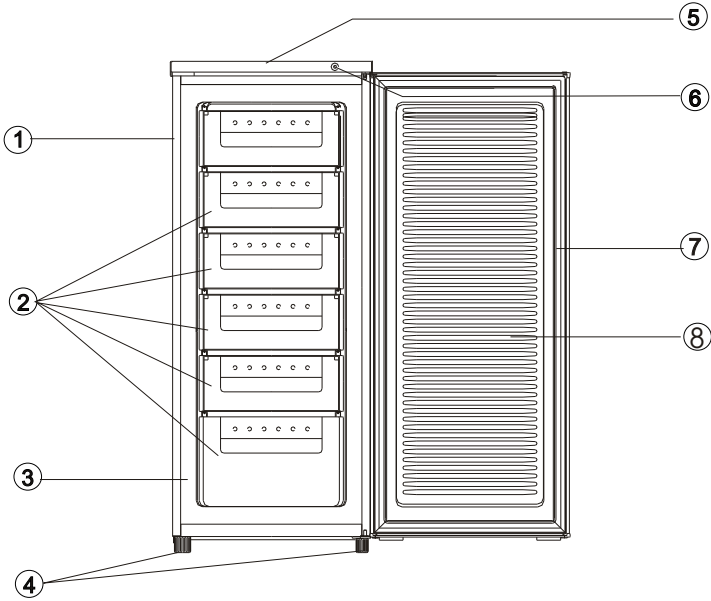

- ① Cabinet
- ② Drawer
- ③ Compressor(at the back of cabinet)
- ④ Adjustable Feet
- ⑤ Worktop
- ⑥ Thermostat Knob
- ⑦ Door Gasket
- ⑧ Door Assembly

Instructions for Installation :

1. Do not tilt the appliance more than 45°.

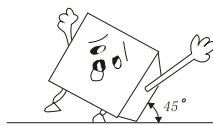

2. To ensure the cabinet does not become damaged, do not apply force to any part of the appliance such as the condenser, the door and its handle. Damage to the cabinet will result in poor performance.

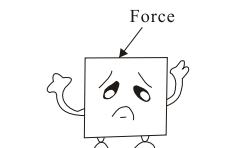

3. For optimum performance ensure correct ventilation space around the appliance.

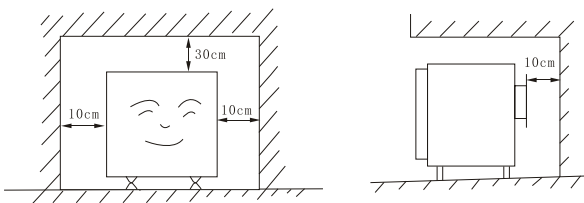

4. Avoid direct sunlight, heat sources and very moist or humid places. Do not install this appliance near flammable, combustible or explosive materials.

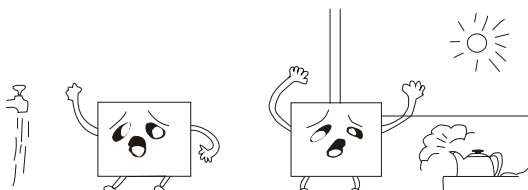

5. Install the appliance on a strong, level floor. Do not install on soft materials such as foam or plastic.
6. The appliance should be left for 2 hours after installation before it is turned on, in order to allow the refrigerant to settle.
7. Avoid installing the appliance in very cold conditions as the performance of the appliance will be impaired.

Instructions for Installation :

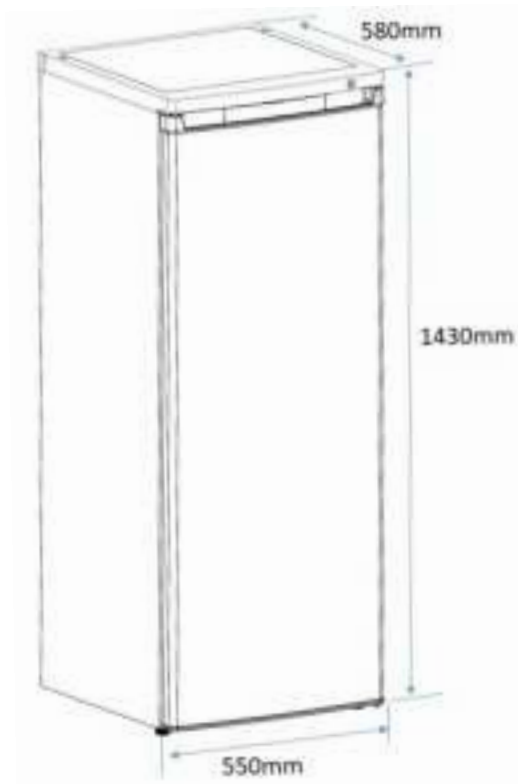

Cautions for Safety :

- This appliance is intended to be used in household and similar applications such as:
 - Staff kitchen areas in shops, offices and other working environments;
 - Farm houses
 - By clients in hotels, motels and other residential type environments;
 - Bed and Breakfast type environments

NOTE: If you wish to limit the use of the appliance to less than the above, this must be clearly stated in the instructions.

Important Safeguards

- Carefully read this instruction manual before using appliance.
- Keep appliance out of reach of young children.
- This appliance is not intended for use by persons (including children) with reduced physical, sensory or mental capabilities, or lack of experience and knowledge, unless they have been given supervision or instruction concerning use of the appliance by a person responsible for their safety.
- Children should be supervised to ensure that they do not play with the appliance.
- Ensure children and babies do not play with plastic bags or any packaging materials.
- This appliance is heavy. Care should be taken when moving it. Do not pull or push using the door. Turn off and unplug before moving.
- Do not attempt to modify this product in any way.
- Whenever possible, the back of the appliance should be close to a wall but leaving the required distance for ventilation as stated in these instructions.
- Do not plug into the power socket before set up is completed. The appliance should be left to stand for 2 hours after installation and before turning on to allow the refrigerant to settle.
- **VERY IMPORTANT:**
 - Ensure that appliance does not get wet (water splashes etc.).
 - Do not use appliance with wet hands.
 - Do not immerse appliance in water or other liquids or use near sinks, baths or showers.
- Always operate the appliance from a power source of the same voltage, frequency and rating as indicated on the product identification plate.
- Position the power supply lead properly so that it will not be walked on, pinched by items placed on or against it or have the appliance resting on it.
- This appliance is intended to be used in household and similar applications such as:
 - staff kitchen areas in shops, offices and other working environments
 - farm houses and by clients in hotels, motels and other residential type environments
 - bed and breakfast type environments
 - catering and similar non-retail applications

WARNING: Keep ventilation openings, in the appliance enclosure or in the built-in structure, clear of obstruction.

WARNING: Do not use mechanical devices or other means to accelerate the defrosting process, other than those recommended by the manufacturer.

WARNING: Do not damage the refrigerant circuit.

WARNING: Do not use electrical appliances inside the food storage compartments of the appliance, unless they are of the type recommended by the manufacturer.

- Do not use appliance if it has been dropped or any part of appliance (including cord or plug) has been damaged. Take appliance to your nearest authorised service centre or qualified dealer for inspection or repair.
- Use only accessories recommended or supplied by an authorised service centre or qualified dealer. The use of accessories not intended for use with this appliance may cause injuries to the user or damage to the appliance.
- Do not install the unit on other appliances, on uneven surfaces or where it could be subject to: heat sources (e.g. radiators or stoves), direct sunlight, excessive dust or mechanical vibrations.
- Appliance should not be used outdoors, placed near a hot gas or electrical burner or placed in a heated oven.
- Do not install near any heat sources such as radiators, heat registers, stoves, or other apparatus that produce heat.
- Do not operate appliance underneath or near flammable or combustible materials (e.g. curtains).
- Unplug this appliance before cleaning or storing or when unused for long periods of time.
- Any type of servicing, apart from ordinary cleaning, must be carried out by an authorised service centre or qualified dealer. There are no user serviceable parts in this appliance.
- If this appliance is used by a third party, please supply the instruction manual with it.
- Do not misuse the cord. Never carry the appliance by the cord or pull to disconnect it from the outlet. Instead, grasp the plug and pull to disconnect.
- To fix stably, the appliance must be placed on a flat and solid surface. It should not be laid on any soft material.
- When positioned or if moving the appliance ensure that it is not set horizontally or declined more than 45° or turned upside down.
- Do not use the unit in very hot or humid places, such as bathrooms or under direct sunlight.
- Close the appliance door immediately after putting in items so the inside temperature will not rise dramatically.
- It is not recommended to use this appliance with an extension cord or power board.
- Do not place any other appliance on top of the appliance.

-
- This appliance is designed for domestic use only, specifically for the storage of edible foodstuffs only.
 - This product has not been designed for any uses other than those specified in this instruction Manual.
 - An empty fridge can be a dangerous attraction to children. If disposing of the fridge, remove gaskets, latches, lids or the entire door from your unused appliance, or take other action to ensure the fridge is harmless.
Contact your local council for proper instruction for disposing of the unused appliance.
 - Do not store explosive substances such as aerosol cans with a flammable propellant in this appliance.



Caution: Risk of Fire The Refrigerant Gas used in this appliance is flammable.

- No liability can be accepted for any damage caused by non-compliance with these instructions or any other improper use or mishandling of appliance.
- This product has not been designed for any uses other than those specified in this booklet

Operation :

1. When operating the appliance for the first time, set the thermostat dial at normal, connect to the electricity and turn it on without loading any food. Wait for the appliance to become cold, usually this takes 2 or 3 hours. Then set the thermostat dial to the desired setting and place foods into the appliance.
2. The temperature of the appliance can be adjusted by turning the thermostatic dial. Setting of the thermostat dial at normal is the most suitable for general operation. Max is the coldest setting.
3. Do not overload the appliance. Where possible open the door less often in order to maintain the temperature of the appliance and save electricity.

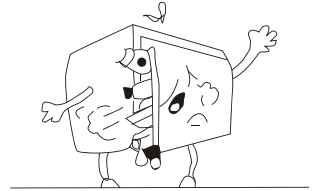

4. Defrost the freezer compartment whenever the layer of frost on the surface reaches 3 or 4 mm. When defrosting, remove all foods, unplug the appliance and open the door. After the frost has melted, discard the water and dry the interior of the appliance. The appliance can then be restarted.

Cautions :

- When defrosting, never use any sharp or metallic objects to remove the frost / ice on the surface of the evaporator as this will damage the evaporator.
- Do not store bottled beverages in the freezer as liquids may expand during freezing causing the bottle to break and damage the appliance.
- If the power supply is turned off for any reason, wait ten minutes before switching the appliance on again.

Cleaning and Maintenance:

1. When cleaning the appliance, first disconnect the appliance from the power supply by removing the plug. Wipe the appliance carefully with a cloth and neutral cleaning agent, then wipe it clean with fresh water.

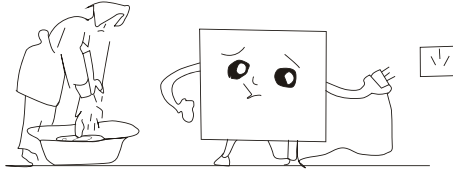

2. Never use acids, chemical solutions, thinners or the like to clean the appliance because they may damage the paint work and plastic components of the appliance.

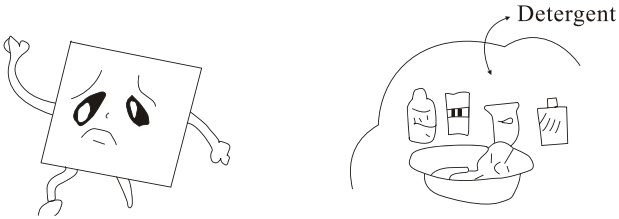

Reversing the Door:

The appliance has the capability of opening the door from either the left or the right side. The unit is delivered to you with the door opening from the left side. To change the opening direction, please follow these instructions.

Note: Before reversing the door, unplug the appliance from the mains or disconnect the electrical power supply.

1. Remove the screws (6) which fix the worktop(7) to disassembly the worktop.
2. Remove the two screws (1) that hold the upper hinge (5) (right side) to the frame.
Take away the upper hinge (5).
3. Lift the door and place it on a padded surface to prevent scratching it.
4. Remove the two screws (8) that hold the lower hinge (2) and make sure to remove the lower hinge (2).
5. Remove the left front leg (4) and transfer it to the right side.
6. Before placing this lower hinge (2), remove the blot-pin (9) and reverse the direction of the lower hinge (2). Then install the lower hinge (2) onto the left side of the lower frame with two screws (8).
7. Insert the bolt-pin (9) to the lower hinge (2).
8. Set the door into place making sure the door seals at the lower hinge (2).
9. While holding the door in the closed position secure the upper hinge (5) in the top frame of left side with two screws (1). Please remember that do not tighten the two screws (1) until the top of the door is levelled with the counter top.
10. Install the worktop onto the top of the cabinet with screws (6).

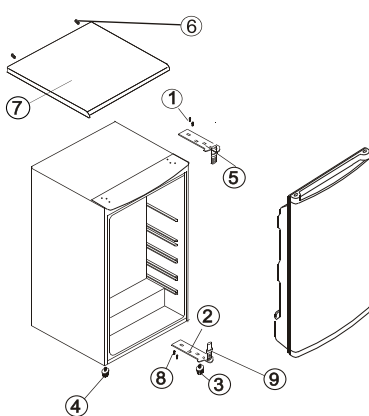

FIGURE 1

Door opening from left side

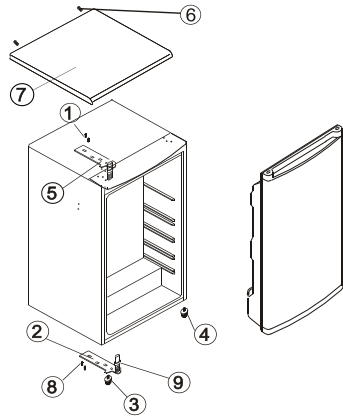

FIGURE 2

Door opening from right side

Troubleshooting:

1. When the appliance does not operate ensure that:
 - The electric power is supplied and the voltage is normal.
 - The fuse or circuit breaker is not blown out or tripped.
 - The power plug is plugged in firmly in the outlet socket.
2. If the appliance is not cool enough ensure that:
 - The thermostat is at the correct setting.
 - There is enough space around the appliance.
 - The doors are not opened too frequently and for too long.
 - The appliance is not overloaded and hot food has not been placed in the appliance.
 - The appliance is not in direct sunlight or placed near a heat source.
3. When the appliance operates too noisily ensure that:
 - The appliance is properly leveled.
 - The appliance is not touching objects around it.
 - The containers or solid packages stored inside are not touching each other.

Note:

- During periods of high humidity, moisture may form on the surfaces of the appliance. This is not a fault and maybe wiped away.
- If after checking the above suggestions your appliance is still not functioning properly, please contact Customer Services without delay.

Warnings:

- * This appliance is not intended for use by persons (including children) with reduced physical, sensory, or mental capabilities, or lack of experience and knowledge, unless they have been given supervision or instruction concerning use of the appliance by a person responsible for their safety.
- * Children should be supervised to ensure that they do not play with the appliance.
- * If the supply cord is damaged, it must be replaced by the manufacturer, its service agent or similarly qualified persons in order to avoid a hazard.
- * Keep ventilation openings, in the appliance enclosure or in the built-in structure clear of obstruction.
- * Do not use mechanical devices or other means to accelerate the defrosting process, other than those recommended by the manufacturer.
- * Do not damage the refrigerant circuit.
- * Do not use electrical appliances inside the food storage compartments of the appliance, unless they are of the type recommended by the manufacturer.

Important Disposal Instructions:



As a responsible retailer we care about the environment.

As such we urge you to follow the correct disposal procedure for your product and packaging materials, this will help conserve natural resources and ensure that it is recycled in a manner that protects health and the environment.

You must dispose of this product and its packaging according to local laws and regulations. Because this product contains electronic components and sometimes batteries, the product and its accessories must be disposed of separately from household waste when the product reaches its end of life.

Contact your local authority to learn about disposal and recycling.

The product should be taken to your local collection point for recycling.

Remove the plug and ensure that any locks or catches are removed, to prevent young children being trapped inside.

R600a Refrigerant:

This appliance may contain a small quantity of environmentally friendly, but flammable, non-synthetic R600a refrigerant:

- * Upon opening and installing your product, check that the tubing of the refrigerant circuit is not damaged during transportation.
- * Leaking refrigerant may cause eye injuries or ignite.
- * The room for installing appliance must be at least 1m per 8g of refrigerant.
The amount of refrigerant in the appliance can be found on the rating plate the back of the unit.
- * Keep ventilation openings in the appliance enclosure or in the built-in structure clear of obstruction.
- * Do not damage the refrigeration circuit.

If you are unsure of the refrigerant type check the rating plate.

Product Information:

- * Model No.: EUFR183W
- * Product dimension: W550 × D580 × H1430 mm
Net Capacity: 167Litres
240Va.c.50Hz
Rated current: 0.78A
Energy consumption: 0.898kW.h/24h
Climate class: T
Refrigerant: R600a(70g)
Insulation blowing gas: Cyclopentane

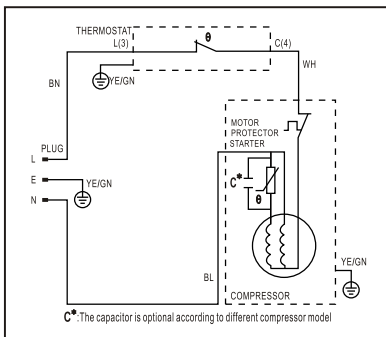

MANUFACTURER GUARANTEE

This warranty is provided in Australia by Glen Dimplex Australia Pty Limited ABN 69 118 275 460 (Phone number 1300 556 816) and in New Zealand by Glen Dimplex New Zealand Limited NZBN 9429000069823 (Phone number 09 274 8265) in respect of the **Euromaid** product.

1. Euromaid Express Warranty

Subject to the exclusions below, we warrant that the product will not have any electrical or mechanical breakdowns within:

- a) In the case of **Euromaid** products used for personal, domestic or household purposes, a period of **2 years** from the date the product is purchased as a brand-new product from a retailer located in Australia / New Zealand.
- b) In the case of **Euromaid** products used for purposes other than personal, domestic or household purposes (including business or commercial use), a period of 90 days from the date the product is purchased as a brand-new product from a retailer located in Australia / New Zealand. **Euromaid** products are designed and intended for domestic use only; and
- c) All warranty repairs must be carried out by Glen Dimplex or their nominated service agent

Note: warranty periods detailed above may vary in line with agreements with select retail and builder partners and may differ between Australia and New Zealand.

The benefits conferred by this express warranty are in addition to the Consumer Guarantees referred to in section 3 and any other statutory rights you may have under the Australian / New Zealand Consumer Law and/or other applicable laws.

2. Warranty exclusions

This express warranty does not apply where:

- a) The product has been installed, used or operated otherwise than in accordance with the product manual or other similar documentation provided to you with the product;
- b) The product requires repairs due to damage resulting from accident, misuse, incorrect installation, insect or vermin infestation, improper liquid spillage, cleaning or maintenance, unauthorised modification, use on an incorrect voltage, power surges and dips, voltage supply problems, tampering or unauthorised repairs by any persons, use of defective or incompatible accessories or exposure to abnormally corrosive conditions, events independent of human control which occurred after the goods left the control of Glen Dimplex;

- c) The repair relates to the replacement of consumable parts such as fuses and bulbs or any other parts of the product which require routine replacement;
- d) You are unable to provide us with reasonable proof of purchase for the product;
- e) the breakdown occurs after the expiry of the express warranty period set out in section 1 or
- f) the product was not purchased in Australia / New Zealand as a brand-new product.

3. Consumer guarantees

Our goods come with guarantees that cannot be excluded under the Australian / New Zealand Consumer Law. You are entitled to a replacement or refund for a major failure and for compensation for any other reasonably foreseeable loss or damage. You are also entitled to have the goods repaired or replaced if the goods fail to be of acceptable quality and the failure does not amount to a major failure.

4. How to make a claim

You may make a claim under this warranty through our website, contacting our customer care line or via email. Contact details for Glen Dimplex Australia and New Zealand can be found at the end of this document

To make a valid claim under this warranty, you must:

- a) Lodge the claim with us as soon as possible and no later than 14 days after you first become aware of the breakdown;
- b) Provide us with the product serial number;
- c) Provide us with reasonable proof of purchase for the product. This can take the form of a store receipt, new home handover form or other payment receipt documentation; and
- d) If required by us, provide us (or any person nominated by us) with access to the premises at which the product is located at times nominated by us (so that we can inspect the product).

5. Warranty claims

If you make a valid claim under this warranty and none of the exclusions set out in section 2 apply, we will, at our election, either repair the product or replace the product with a product of identical specification (or where the product is superseded or no longer in stock, with a product of as close a specification as possible).

Goods presented for repair may be replaced by refurbished goods of the same type rather than being repaired. Refurbished parts may be used to repair the goods.

Products are designed and supplied for normal domestic use. We will not be liable to you under this warranty for business loss or damage of any kind whatsoever.

Glen Dimplex Australia Pty Ltd

www.glendimplex.com.au

Australia

Ph: 1300 556 816

customer.care.ha@glendimplex.com.au

Glen Dimplex New Zealand Ltd

www.glendimplex.co.nz

New Zealand

Ph: 09 274 8265

nztechserv@glendimplex.co.nz

READ THE INSTRUCTION BOOKLET BEFORE INSTALLING AND USING THE APPLIANCE.

The manufacturer will not be responsible for any damage to property or to persons caused by incorrect installation or improper use of the appliance.

The manufacturer is not responsible for any inaccuracies, due to printing or transcription errors, contained in this manual. In addition, the appearance of the figures reported is also purely indicative.

The manufacturer reserves the right to make changes to its products when considered necessary and useful, without affecting the essential safety and operating characteristics.

Glen Dimplex constantly seeks ways to improve the specifications and designs of their products. Whilst every effort is made to produce up to date literature, this document should not be regarded as an infallible guide. Actual product only should be used to derive cut out sizes.

All appliances must be installed by a qualified person/s with adherence to the relevant electrical, plumbing and building codes, with compliance being issued as required by state or national legislation.

Additionally, all upright cookers must have the anti-tilt device installed correctly in adherence to the relevant standards by a licenced installer.

For maximum effectiveness and efficiency all rangehoods should be installed with the use of ductwork, by a licenced installer with adherence to the relevant state and national building codes and regulations.

All Glen Dimplex appliances are for Domestic use only, and must be installed by a licence installer into Domestic Applications only, without exception and to the required Authorities guidelines. Any installation outside of this will VOID warranty. Alfresco areas are not a Domestic application.

Euromaid

Distributed by:

Glen Dimplex Australia Pty Ltd

www.glendimplex.com.au

Glen Dimplex New Zealand Ltd

www.glendimplex.co.nz

For service advice, please contact the Customer Care Centre by phone or email below.

Australia

Ph: 1300 556 816

customer.care.ha@glendimplex.com.au

New Zealand

Ph: 09 274 8265

nztechserv@glendimplex.co.nz