

Emerson™ Wireless 1410 A/B and 1410D Gateway with 781 Field Link



WirelessHART

NOTICE

This guide provides basic guidelines for the Emerson Wireless 1410 and 1410D Gateway. It does not provide instructions for diagnostics, maintenance, service, or troubleshooting. Refer to the Emerson Wireless Gateway 1410 [Reference Manual](#) for more information and instructions. The manuals and this guide are available electronically on Emerson.com/Rosemount.

This device complies with Part 15 of the FCC Rules. Operation is subject to the following conditions. This device may not cause harmful interference. This device must accept any interference received, including interference that may cause undesired operation. This device must be installed to ensure a minimum antenna separation distance of 20 cm from all persons.

⚠ WARNING**Explosion hazard**

- Do not make or break any connections to the Gateway while circuits are live unless area is known to be non-hazardous.

Explosions could result in death or serious injury.

- Installation of this device in an explosive environment must be in accordance with the appropriate local, national, and international standards, codes, and practices. Review the Product Certifications section for any restrictions associated with a safe installation.
- Avoid contact with the leads and terminals. High voltage that may be present on leads can cause electrical shock.

Potential electrostatic charging hazard

- The Gateway enclosure is plastic. Use care in handling and cleaning when in explosive environments to avoid an electrostatic discharge.

Contents

Wireless planning	3	Software installation (optional)	20
PC requirements	3	Verify operations	21
Initial connection and configuration	3	Product Certification	23
Physical installation	11		

1.0 Wireless planning

1.1 Power up sequence

The Gateway should be installed and functioning properly before power modules are installed in any wireless field devices. Wireless field devices should also be powered up in order of proximity from the Gateway beginning with the closest. This will result in a simpler and faster network installation.

1.2 Antenna position

The antenna should be positioned vertically and be approximately 6 ft. (2 m) from large structures or buildings to allow for clear communication to other devices.

1.3 Mounting height

For optimal wireless coverage, the remote antenna is ideally mounted 15–25 ft. (4.6–7.6 m) above ground or 6 ft. (2 m) above obstructions or major infrastructure.

2.0 PC requirements

2.1 Operating system (optional software only)

- Microsoft® Windows™ Server 2008 (Standard Edition), Service Pack 2
- Windows Server 2008 R2 Standard Edition, Service Pack 1
- Windows 7 Professional, Service Pack 1
- Windows 7 Enterprise, Service Pack 1
- Windows 8 Enterprise, Service Pack 1
- Windows 10 Enterprise, Service Pack 1

2.2 Applications

Configuration of the Gateway is done through a secure web interface. Recent versions of the following browsers are supported:

- Internet Explorer®
- Chrome™ browser
- Mozilla Firefox®
- Microsoft Edge

2.3 Hard disk space

- AMS Wireless Configurator: 1.5 GB
- Gateway Setup CD: 250 MB

3.0 Initial connection and configuration

To configure the Gateway, a local connection between a PC/Mac/laptop and the Gateway needs to be established. The Emerson 1410 and 1410D are operationally equivalent and the following instructions are applicable to both models.

3.1 Powering the Gateway

For both Emerson Wireless 1410A/B and the 1410D, bench top power will be needed to power the Gateway by wiring a 10.5–30 VDC (20–30 VDC if a 781 is connected with I.S. barriers to the Emerson 1410D) power source, with a capacity of at least 250 mA to the power terminals.

Figure 1. Emerson 1410A/B Gateway Housing

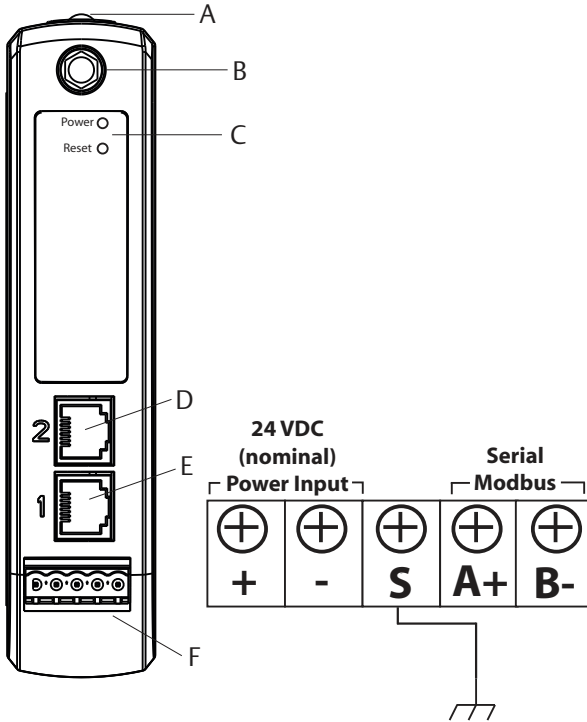

- A. DIN Rail clip
- B. SMA to N type connection
- C. Power light. During normal operation the power indicator will be green.
- D. Ethernet port 2. When this port is activated, the factory IP address is 192.168.2.10. See [Table 1 on page 9](#).
- E. Ethernet port 1. Use for standard communication to the webserver or other protocols enabled on the Gateway. The factory IP address is 192.168.1.10. See [Table 1 on page 9](#).
- F. Emerson 1410 power and serial connection. Black terminal included in the box.

Figure 2. Emerson 1410D Gateway Wiring

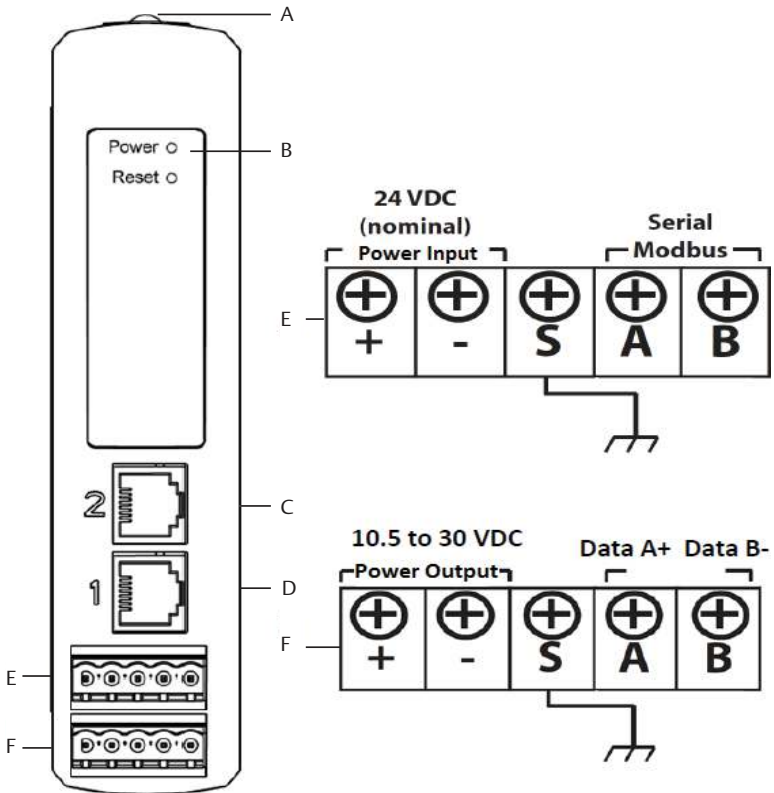

- A. DIN Rail Clip
- B. Power light. During normal operation the power indicator will be green.
- C. Ethernet port 2. When this port is activated, the factory IP address is 192.168.2.10. See [Table 1 on page 9](#).
- D. Ethernet port 1. When this port is activated, the factory IP address is 192.168.1.10. See [Table 1 on page 9](#).
- E. Emerson 1410 Power and Serial connections. Black terminal included in the box.
- F. Emerson Wireless 781 Field Link power and data connections. Black terminal included in box.

3.2 Establishing a connection

Connect the PC/laptop to the Ethernet 1 (Primary) receptacle on the Gateway using an Ethernet cable.

Windows 7

1. Click the **Internet Access icon** on the bottom right of the screen.

Figure 3. Internet Access



2. Select the **Network and Sharing Center**.
3. Select **Local Area Connection**.

Figure 4. Local Area Connection

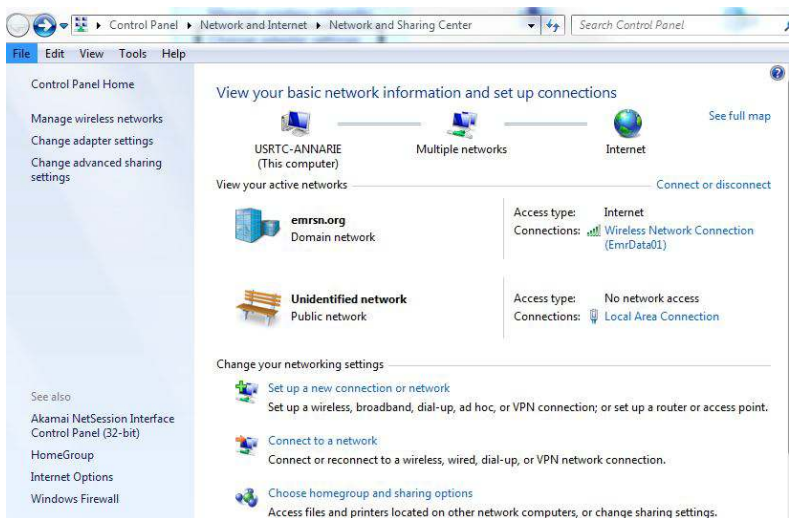

4. Select **Properties**.

5. Select **Internet Protocol Version 4 (TCP/IPv4)** then select **Properties**.

Figure 5. Internet Protocol Version 4 (TCP/IPv4)

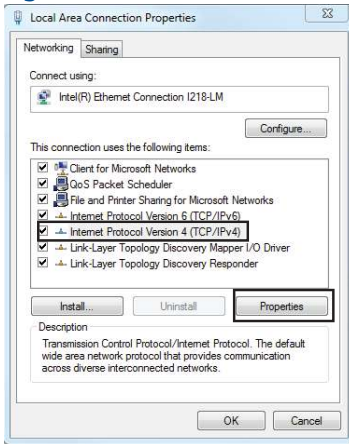

Note

If the PC/laptop is from another network, record the current IP address and other settings so the PC/laptop can be returned to the original network after the Gateway has been configured.

6. Select the **Use the following IP address** button.

Figure 6. IP Address

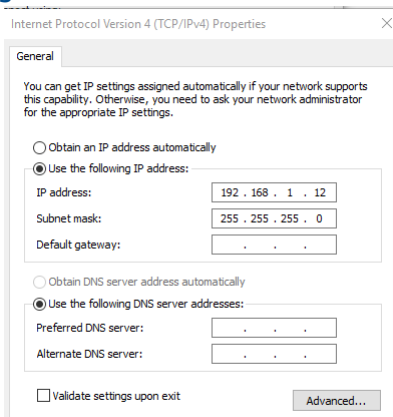

7. In the *IP address* field, enter 192.168.1.12 (DeltaV Ready enter 10.5.255.12).
8. In the *Subnet mask* field, enter 255.255.255.0.

9. Select **OK** for both the *Internet Protocol (TCP/IP) Properties* window and the *Local Area Connection Properties* window.

Windows 10

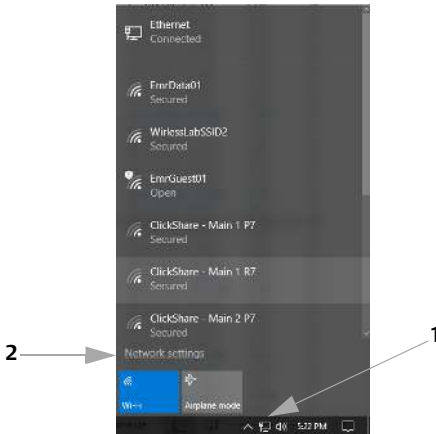

1. Select the network icon in the lower right corner.
2. Select the **Network settings** link.
3. Select **Ethernet** on the left hand side of the *Network Settings dialog*.

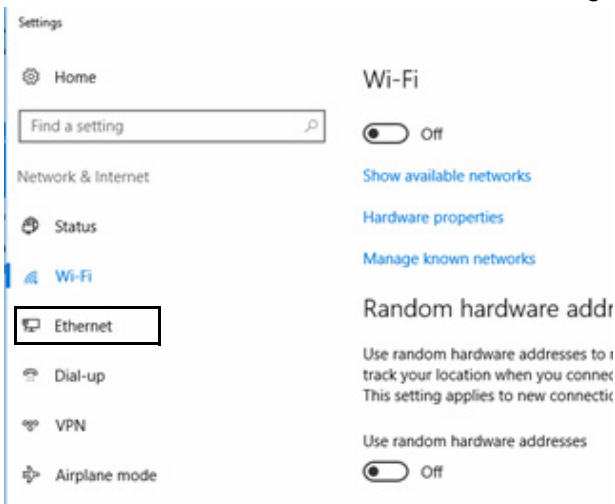

4. Select **Change adapter options**.

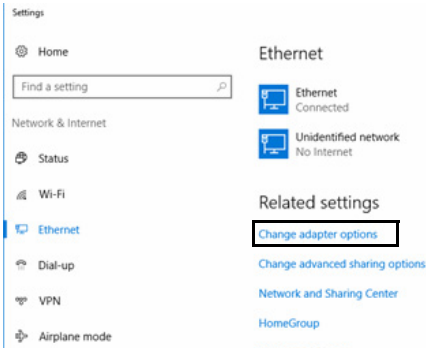

5. See steps 4-10 from [Windows 7](#) instructions.

Note

Connecting to the Gateway's secondary Ethernet port will require different network settings.

Table 1. TCP/IP Network Settings

	Gateway	PC/laptop/tablet	Subnet
Ethernet 1	192.168.1.10	192.168.1.12	255.255.255.0
Ethernet 2	192.168.2.10	192.168.2.12	255.255.255.0

Disable proxies

1. Open web browser.
2. Navigate *Tools > Internet Options > Connections > LAN Settings* (may be a different process for other browsers).
3. Under *Proxy server*, uncheck the **Use a proxy server...** box.

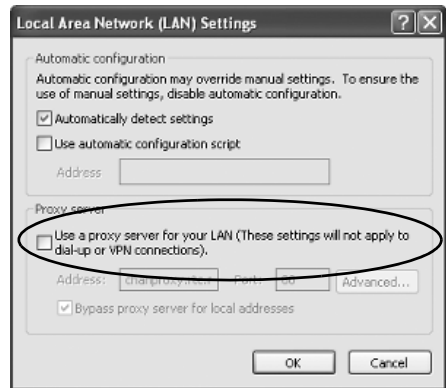

3.3 Configure the Gateway

To complete initial configuration for the Gateway:

1. Access the default web page for the Gateway at <https://192.168.1.10>
 - a. Log on as Username: admin
 - b. Type in password: default



2. Navigate to *System Settings > Gateway > Ethernet Communication* to enter the Network Settings.
 - a. Configure a static IP Address or set for DHCP and enter a Hostname.

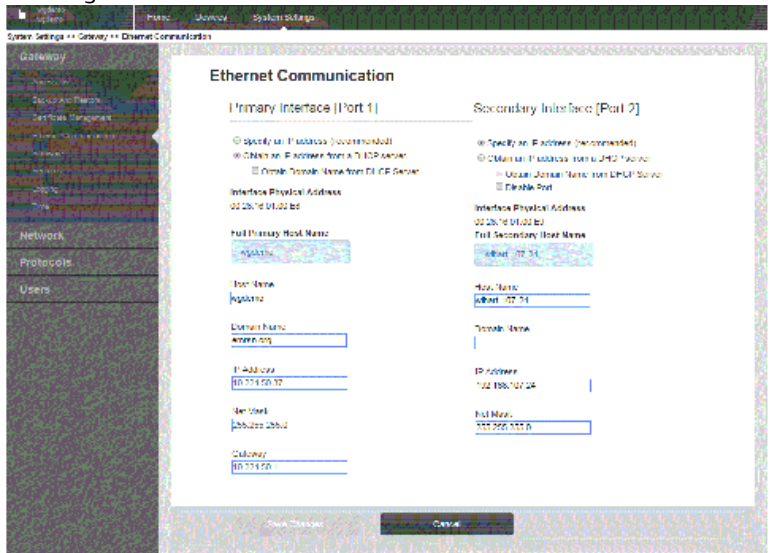

- b. Restart application at *System Settings > Gateway > Backup and Restore > Restart Apps*.

Note

Resetting applications will temporarily disable communications with field devices.

3. Disconnect the power and Ethernet cable from the Gateway.

4.0 Physical installation

4.1 Emerson 1410A/B and 1410D mounting

The unit can be snapped onto a DIN TS35/7.5 or TS35/15 rail system. To clip the unit onto the DIN rail, see [Figure 7](#).

1. Tilt the unit at a slight angle allowing the lower lip of the chassis to catch the bottom of the DIN rail.
2. Apply pressure forward to snap the back of the unit securely onto the DIN rail.

Figure 7. Installing

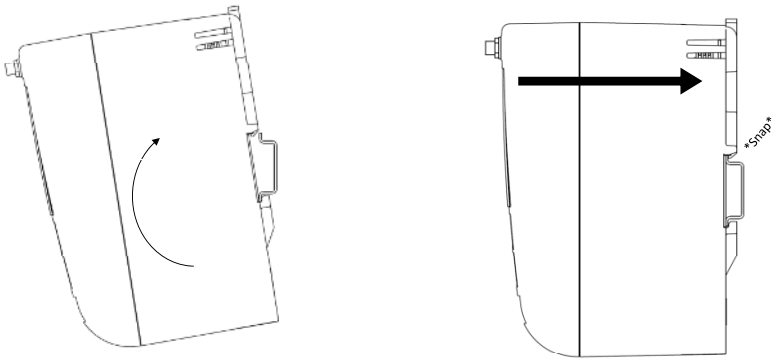

To remove the unit, see [Figure 8](#).

1. Place a flat or rounded object (such as a screw driver) into the DIN clip and apply a slight pressure downwards on the object.
2. Once the unit is released from the DIN rail, pull backwards and down to successfully disengage.

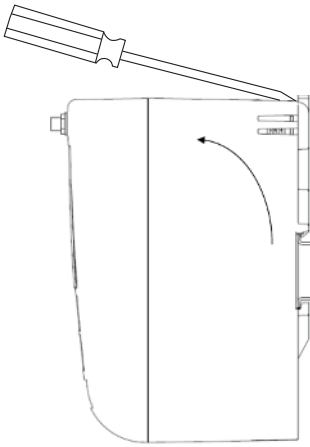
Figure 8. Removing**NOTICE**

When mounting the unit in an electrical enclosure or other location, comply with the appropriate local and national installation codes. Verify that the installer, associated hardware, and installation equipment used have the proper certifications for the specific type of installation being performed. Before installation, verify if local codes require a permit and/or an inspection before energizing. When planning the installation, account for routing the antenna cable within the enclosure.

Note

Do not mount the antenna within a metal enclosure. To avoid damage to sensitive RF components, do not remove protective cap from the Gateway SMA connector until ready to install the antenna.

4.2 Connecting the Emerson 1410D with 781

There are two main connection configurations for the Emerson 1410D and 781: with and without barriers. The location and hazardous approval option of the Emerson 781 determines whether it needs to be installed with barriers.

Installation without barriers

A shielded twisted pair cable is needed for connecting the Emerson 1410D and 781 (refer to [Figure 9](#)). The Emerson 781 can be located up to 656 ft. (200m) from the Emerson 1410D.

Figure 9. Emerson 1410D and 781 without Barriers Installation

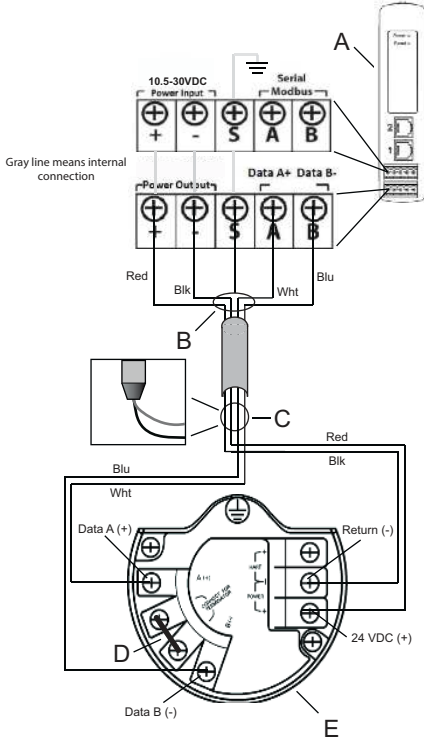

- A. Emerson Wireless 1410D Gateway
- B. Attach shield pair cable (Belden 3084A or equivalent)
- C. Tape back shield wire and foils
- D. Short these terminals to enable 250 Ω terminating resistor
- E. Emerson Wireless 781 Field Link

Figure 11. Emerson 1410D and 781 with Additional Power Supplied Barrier Installation

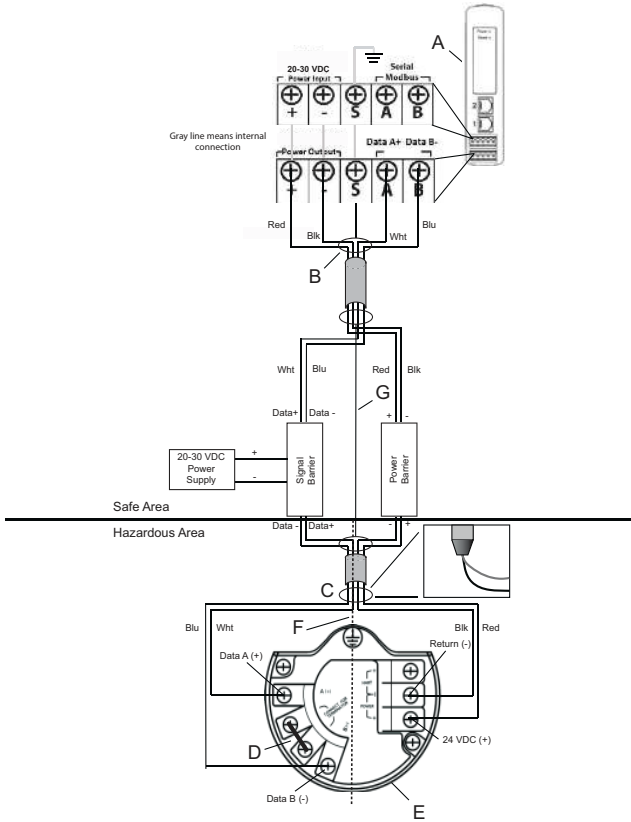

- A. Emerson Wireless 1410D Gateway
- B. Attach shield pair cable (Belden 3084A)
- C. Tape back shield wire and foils
- D. Short these terminals for 250 Ω
- E. Emerson Wireless 781 Field Link
- F. I.S. segregation
- G. Shield

Recommendation

Signal barrier

- GM-International D1016S

Power barrier

- Stahl 9176 10-16-00

Shield grounding

The shield of the twisted pair cable needs to be grounded using the grounding terminal on the Emerson 1410D, and it should be taped back on the Emerson 781 side.

Emerson 1410D Grounding

The Emerson 1410D DIN rail cabinet must be grounded as well. A #6 AWG (4.11 mm European) copper wire bonding connector with the shortest length possible, no sharp bends, and no coiling is recommended.

Figure 12. Emerson 1410D Grounding

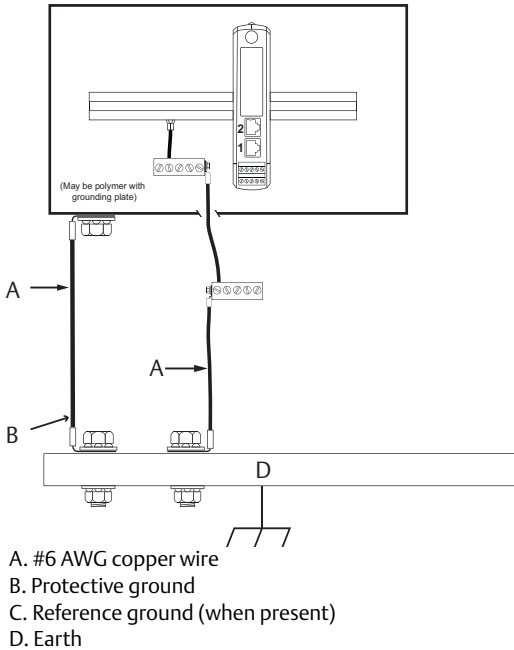

Emerson 781 grounding

Grounding of the electronics enclosure should be done in accordance with local and national installation codes. Grounding is accomplished through the external case grounding terminal.

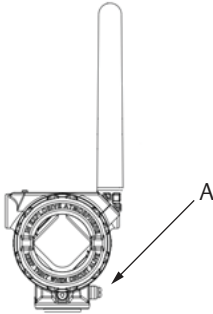

A. Grounding lug

Terminating resistances

For best performance, the terminating resistances should be matched across the Emerson 1410D, 781, and the signal barrier. The Emerson 1410D has an integral $250\ \Omega$ terminating resistor. Short the Emerson 781 terminator terminals to engage a $250\ \Omega$ resistor (note D of [Figure 10](#) and [Figure 11](#)). The recommended barriers can also be switched to $250\ \Omega$.

4.3 Connecting the Emerson 1410A/B with the remote antenna

⚠ WARNING

When installing remote mount antennas for the Gateway, always use established safety procedures to avoid falling or contact with high-power electrical lines.

Install remote antenna components for the Gateway in compliance with local and national electrical codes and use best practices for lightning protection.

Before installing, consult with the local area electrical inspector, electrical officer, and work area supervisor.

The Gateway remote antenna option is specifically engineered to provide installation flexibility while optimizing wireless performance and local spectrum approvals. To maintain wireless performance and avoid non-compliance with spectrum regulations, do not change the length of cable or the antenna type.

If the supplied remote mount antenna kit is not installed per these instructions, Emerson is not responsible for wireless performance or non-compliance with spectrum regulations.

Use only Emerson provided remote antenna, coaxial RF cable, and lightning arrester. The remote antenna lightning arrester must be installed and grounded in accordance with [Figure 13](#).

Locate the remote antenna to achieve optimal wireless performance. Ideally this will be 15–25 ft. (4.6–7.6 m) above the ground or 6 ft. (2 m) above obstructions or major infrastructure. To install the remote antenna, use one of the following procedures:

Installation of WL2/WN2 option

1. Mount the antenna on a 1¹/₂- to 2-in. pipe mast using the supplied mounting equipment.
2. Connect the lightning arrester either to the electrical cabinet or directly outside the wall or right outside the wall (depending on where the Gateway is located).
3. Install the grounding lug, lock washer, and nut on top of the lightning arrester.
4. Bond the grounding terminal of the lightning arrester to a common earth point using individual high integrity, low resistance means as shown in [Figure 13](#).
5. The DIN rail cabinet must be grounded as well. A #6 AWG (or 4.11 mm European) copper wire bonding conductor with the shortest length possible, no sharp bends, and no coiling is recommended.
6. All the outdoor connections should be made hand tight plus an 1/8th turn with a wrench and wrapped with the coaxial seal (shown in [Figure 14](#)).
7. Ensure the mounting mast, lightning arrester, and Gateway are grounded according to local/national electrical code.

Any spare lengths of coaxial cable should be placed in 1 ft. (0.3 m) coils.

Figure 13. Installation of WL2/WN2 Option

Indoor/outdoor cabinet and antenna

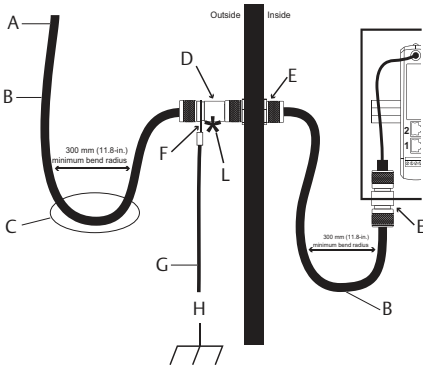

Outdoor cabinet and antenna

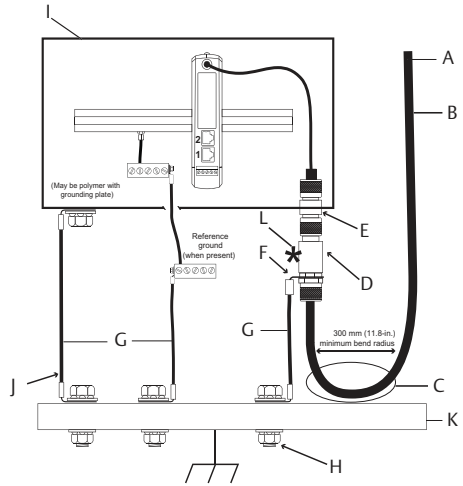

- A. To antenna
- B. Coaxial RF
- C. Drip loop
- D. Lightning arrester
- E. Type N bulkhead connector
- F. 5/8-in. ring terminal

- G. #6 AWG copper wire
- H. Transient protection ground
- I. Outdoor rated enclosure
- J. Protective ground
- K. Earth
- L. Seal per Figure 13

Note: Weather proofing is required

The remote mount antenna kit includes coaxial sealant for the cable connections for the lightning arrester, antenna, and Gateway. The coaxial sealant must be applied to guarantee performance of the wireless field network. See Figure 14 for details on how to apply weather proofing.

Figure 14. Applying Coaxial Sealant to Cable Connections



Table 2. Remote Antenna Kit Options

Kit option	Antenna	Cable 1	Cable 2	Lightning arrester
WL2	1/2 Wavelength Dipole Omni-Directional +6 dB Gain	50 ft. (15,2 m) LMR-400	N/A	Head mount, jack to plug Gas discharge tube 0.5 dB insertion loss
WN2	1/2 Wavelength Dipole Omni-Directional +8 dB Gain	25 ft. (7,6 m) LMR-400	N/A	Head mount, jack to plug Gas discharge tube 0.5 dB insertion loss

4.4 Connect to the host system

1. Wire the Gateway's Ethernet 1 (Primary) or Serial Output connection to the Host System Network or Serial I/O (see [Figure 1](#) and [Figure 2](#) for hardware drawings).
2. For serial connections, make sure all terminations are clean and secure to avoid wiring connection problems.

4.5 Best practice

Twisted shielded pair cable is generally used to wire the serial connection, and it is standard practice to ground the shield on the serial host side leaving the shield floating on the Gateway side. Insulate the shield to avoid grounding issues.

In accordance with Emerson *WirelessHART*® security guidelines (Emerson Wireless Security [Whitepaper](#)), the Gateway should be connected to the Host System via a LAN (Local Area Network) and not a WAN (Wide Area Network).

5.0 Software installation (optional)

The 2-disk software pack contains the Security Setup Utility (only required for secure host connections or OPC communications) and AMS Wireless Configurator. The Security Setup Utility is located on Disk 1. To install the software:

1. Exit/close all Windows programs, including any running in the background, such as virus scan software.
2. Insert Disk 1 into the CD/DVD drive of the PC.
3. If the setup program does not appear, go into the disc's file and run **autorun.exe**.
4. Follow the prompts.

AMS Wireless Configurator is located on Disk 2. To install the software:

1. Exit/close all Windows programs, including any running in the background, such as virus scan software.
2. Insert Disk 2 into the CD/DVD drive of the PC.
3. Select **Install** from the menu when the AMS Wireless Configurator setup begins.
4. Follow the prompts.
5. Allow AMS Wireless Configurator to reboot PC.
6. Do not remove the disk from the CD/DVD drive.
7. Installation will resume automatically after login.
8. Follow the prompts.

Note

If the autorun function is disabled on the PC, or installation does not begin automatically, double click D:\SETUP.EXE (where D is the CD/DVD drive on the PC) and select **OK**.

For more information about the Security Setup Utility and AMS Wireless Configurator, see the Emerson Wireless Gateway 1410 [Reference Manual](#).

6.0 Verify operations

Operation is verified through the web interface by opening a web browser from any PC on the host system network and entering the Gateway IP address or DHCP host name in the address bar. If the Gateway has been connected and configured properly, the security alert will be displayed followed by the log in screen.

Figure 15. Gateway Log In Screen

Unlock?

Please enter your password to unlock this section.

Username

Password

Do not attempt to log on unless you are an authorized user. Unauthorized access will be prosecuted to the fullest extent of the law.

Login

The Gateway is now ready to be integrated into the host system. If wireless field devices were ordered with the Gateway, they were preconfigured with the same Network ID and Join Key information. Once the field devices are powered, they will appear on the wireless network and communications can be verified under the Explore tab using the web interface. The time needed for the network to form will depend on the number of devices.

For more detailed installation instructions, see the Emerson Wireless Gateway 1410 [Reference Manual](#).

7.0 Product Certification

Rev 2.0

7.1 European Directive Information

A copy of the EC Declaration of Conformity can be found at the end of the Quick Start Guide. The most recent revision of the EC Declaration of Conformity can be found at Emerson.com/Rosemount.

7.2 Telecommunication Compliance

All wireless devices require certification to ensure they adhere to regulations regarding the use of the RF spectrum. Nearly every country requires this type of product certification. Emerson is working with governmental agencies around the world to supply fully compliant products and remove the risk of violating country directives or laws governing wireless device usage.

7.3 FCC and IC

This device complies with Part 15 of the FCC Rules. Operation is subject to the following conditions: This device may not cause harmful interference. This device must accept any interference received, including interference that may cause undesired operation. This device must be installed to ensure a minimum antenna separation distance of 20 cm from all persons.

7.4 Ordinary Location Certification

As standard, the transmitter has been examined and tested to determine that the design meets the basic electrical, mechanical, and fire protection requirements by a nationally recognized test laboratory (NRTL) as accredited by the Federal Occupational Safety and Health Administration (OSHA).

North America

N5 U.S.A. Division 2

Certificate: 2646342 (CSA)

Standards: CAN/CSA C22.2 No. 0-10, CSA C22.2 No. 213-M1987 (2013), CSA C22.2 No. 61010-1 - 2012, ANSI/ISA-12.12.01 - 2012, UL61010-1, 3rd Edition

Markings: Suitable for CL I, DIV 2, GP A, B, C, D;

Temperature Code: T4 (-40 °C ≤ T_a ≤ 70 °C)

Note

- Shall be powered by a class 2 power supply.
 - Suitable for dry indoor locations only.
 - Equipment must be installed in a suitable tool accessible enclosure subject to the end use application.
 - Using the Emerson 1410D and the 781 Wireless Field Link in a hazardous location requires barriers between the two units
-

Canada

N6 Canada Division 2

Certificate: 2646342 (CSA)

Standards: CAN/CSA C22.2 No. 0-10, CSA C22.2 No. 213-M1987 (R2013),
CSA C22.2 No. 61010-1 - 2012, ANSI/ISA-12.12.01 - 2012,
UL61010-1, 3rd Edition

Markings: Suitable for CLI, DIV 2, GP A, B, C, D

Temperature code: T4 ($-40\text{ }^{\circ}\text{C} \leq T_a \leq 70\text{ }^{\circ}\text{C}$)

Note

- Shall be powered by a class 2 power supply.
 - Suitable for dry indoor locations only.
 - Equipment must be installed in a suitable tool accessible enclosure subject to the end use application.
 - Using the Emerson 1410D and the 781 Wireless Field Link in a hazardous location requires barriers between the two units.
-

Europe

N1 ATEX Type n

Certificate: Baseefa14ATEX0125X

Standards: EN 60079-0: 2012, EN 60079-15: 2010

Markings:  II 3 G Ex nA IIC T4 Gc, T4 ($-40\text{ }^{\circ}\text{C} \leq T_a \leq +75\text{ }^{\circ}\text{C}$), $V_{MAX} = 30\text{ Vdc}$

Special Conditions for Safe Use (X):

1. The equipment must be installed in an area of not more than Pollution Degree 2 as defined in IEC 60664-1, and in an enclosure that provides a degree of protection of at least IP54 and meets the relevant requirements of EN 60079-0 and EN 60079-15.
2. External connections to the equipment must not be inserted or removed unless either the area in which the equipment is installed is known to be non-hazardous, or the circuits connected have been de-energized.
3. The equipment is not capable of withstanding the 500 V electrical strength test as defined in clause 6.5.1 of EN 60079-15: 2010. This must be taken into account during installation.
4. When fitted, the surface resistivity of the remote antenna is greater than $1\text{ G}\Omega$. To avoid electrostatic charge build up, it must not be rubbed with a dry cloth or cleaned with solvents.

Note

Currently not available for Emerson 1410D option.

International

N7 IECEx Type n

Certificate: IECEx BAS 14.0067X

Standards: IEC 60079-0: 2011, IEC 60079-15: 2010

Markings: Ex nA IIC T4 Gc, T4 ($-40\text{ }^{\circ}\text{C} \leq T_a \leq +75\text{ }^{\circ}\text{C}$), $V_{MAX} = 30\text{ Vdc}$

Special Conditions for Safe Use (X):

1. The equipment must be installed in an area of not more than Pollution Degree 2 as defined in IEC 60664-1, and in an enclosure that provides a degree of protection of at least IP54 and meets the relevant requirements of EN 60079-0 and EN 60079-15.
2. External connections to the equipment must not be inserted or removed unless either the area in which the equipment is installed is known to be nonhazardous, or the circuits connected have been de-energized.
3. The equipment is not capable of withstanding the 500 V electrical strength test as defined in clause 6.5.1 of EN 60059-15: 2010. This must be taken into account during installation.
4. When fitted, the surface resistivity of the remote antenna is greater than 1 GW. To avoid electrostatic charge build-up, it must not be rubbed with a dry cloth or cleaned with solvents.

Note

Currently not available for Emerson 1410D option.

EAC - Belarus, Kazakhstan, Russia

NM Technical Regulation Customs Union (EAC) Type n

Certificate: TC RU C-US.Gb05.B.01111

Markings: 2Ex nA IIC T4 Gc X, T4(-40 °C ≤ T_a ≤ +75 °C), V_{MAX} = 30 Vdc



Special Condition for Safe Use (X):



1. See certificate for special conditions.

Note

Currently not available for Emerson 1410D option.

Figure 16. Emerson 1410 Wireless Gateway Declaration of Conformity

	
EU Declaration of Conformity	
No: RMD 1093 Rev. G	
We,	
Rosemount, Inc. 8200 Market Boulevard Chanhassen, MN 55317-9685 USA	
declare under our sole responsibility that the product,	
Rosemount 1410 Wireless Gateway	
manufactured by,	
Rosemount, Inc. 8200 Market Boulevard Chanhassen, MN 55317-9685 USA	
to which this declaration relates, is in conformity with the provisions of the European Union Directives, including the latest amendments, as shown in the attached schedule.	
Assumption of conformity is based on the application of the harmonized standards and, when applicable or required, a European Union notified body certification, as shown in the attached schedule.	
	Vice President of Global Quality
(signature)	(function)
Chris LaPoint	1-Feb-19
(name)	(date of issue)
Page 1 of 3	

 **EU Declaration of Conformity** 

No: RMD 1093 Rev. G

EMC Directive (2014/30/EU)

Harmonized Standards:
EN 61326-1: 2013



Radio Equipment Directive (RED) (2014/53/EU)

Harmonized Standards:
EN 300 328 V2.1.1
EN 301 489-17: V3.2.0
EN 60950-1: 2006+A11+A12+A1+A2
EN 50371: 2002

ATEX Directive (2014/34/EU)

Baseefa14ATEX0125X – Type n Certificate
Equipment Group II, Category 3 G
Ex nA IIC T4 Gc
Harmonized Standards:
EN 60079-0: 2012 + A11:2013
EN 60079-15: 2010

Page 2 of 3

 **EU Declaration of Conformity** 

No: RMD 1093 Rev. G

ATEX Notified Body

SGS FIMKO OY [Notified Body Number: 0598]
P.O. Box 30 (Särkiniementie 3)
00211 HELSINKI
Finland

ATEX Notified Body for Quality Assurance

SGS FIMKO OY [Notified Body Number: 0598]
P.O. Box 30 (Särkiniementie 3)
00211 HELSINKI
Finland

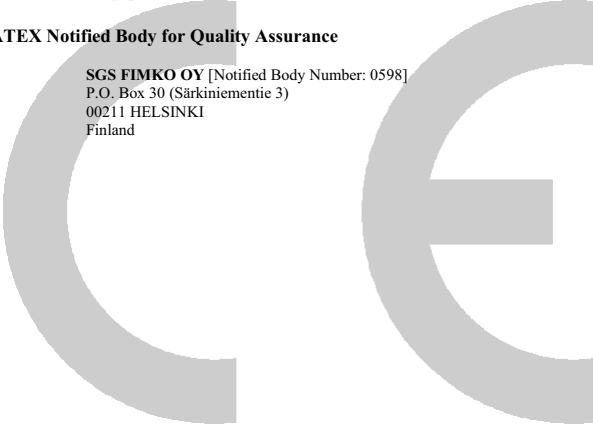

Page 3 of 3

含有China RoHS 管控物质超过最大浓度限值的部件型号列表 Rosemount 1410
List of Rosemount 1410 Parts with China RoHS Concentration above MCVs

部件名称 Part Name	有害物质 / Hazardous Substances					
	铅 Lead (Pb)	汞 Mercury (Hg)	镉 Cadmium (Cd)	六价铬 Hexavalent Chromium (Cr +6)	多溴联苯 Polybrominated biphenyls (PBB)	多溴联苯醚 Polybrominated diphenyl ethers (PBDE)
电子组件 Electronics Assembly	X	O	O	O	O	O

本表格系依据SJ/T11364的规定而制作。

This table is proposed in accordance with the provision of SJ/T11364.

O: 意为该部件的所有均质材料中该有害物质的含量均低于GB/T 26572所规定的限量要求。

O: Indicate that said hazardous substance in all of the homogeneous materials for this part is below the limit requirement of GB/T 26572.

X: 意为在该部件所使用的所有均质材料里，至少有一类均质材料中该有害物质的含量高于GB/T 26572所规定的限量要求。

X: Indicate that said hazardous substance contained in at least one of the homogeneous materials used for this part is above the limit requirement of GB/T 26572.



Global Headquarters

Emerson Automation Solutions
6021 Innovation Blvd.
Shakopee, MN 55379, USA
+1 800 999 9307 or +1 952 906 8888
+1 952 949 7001
RFQ.RMD-RCC@Emerson.com

North America Regional Office

Emerson Automation Solutions
8200 Market Blvd.
Chanhassen, MN 55317, USA
+1 800 999 9307 or +1 952 906 8888
+1 952 949 7001
RMT-NA.RCCRFQ@Emerson.com

Latin America Regional Office

Emerson Automation Solutions
1300 Concord Terrace, Suite 400
Sunrise, FL 33323, USA
+1 954 846 5030
+1 954 846 5121
RFQ.RMD-RCC@Emerson.com

Europe Regional Office

Emerson Automation Solutions
Neuhofstrasse 19a P.O. Box 1046
CH 6340 Baar
Switzerland
+41 (0) 41 768 6111
+41 (0) 41 768 6300
RFQ.RMD-RCC@Emerson.com

Asia Pacific Regional Office

Emerson Automation Solutions
1 Pandan Crescent
Singapore 128461
+65 6777 8211
+65 6777 0947
Enquiries@AP.Emerson.com

Middle East and Africa Regional Office

Emerson Automation Solutions
Emerson FZE P.O. Box 17033
Jebel Ali Free Zone - South 2
Dubai, United Arab Emirates
+971 4 8118100
+971 4 8865465
RFQ.RMTMEA@Emerson.com



[Linkedin.com/company/Emerson-Automation-Solutions](https://www.linkedin.com/company/Emerson-Automation-Solutions)



[Twitter.com/Rosemount_News](https://twitter.com/Rosemount_News)



[Facebook.com/Rosemount](https://www.facebook.com/Rosemount)



[Youtube.com/user/RosemountMeasurement](https://www.youtube.com/user/RosemountMeasurement)



[Google.com/+RosemountMeasurement](https://www.google.com/+RosemountMeasurement)

Emerson Terms and Conditions of Sale are available upon request. The Emerson logo is a trademark and service mark of Emerson Electric Co. Rosemount is a mark of one of the Emerson family of companies. All other marks are the property of their respective owners. © 2019 Emerson. All rights reserved.