

Save these instructions for future use!

DESCRIPTION

The 16E09-101 is a single stage electronic temperature control, with a Nema 1 rated enclosure, and can be used for most applications within the temperature control range of -40° to 220°F, (-40° to 104°C). The control has an SPDT (Single Pole Double Throw) output load relay.

The control has user options to control differential, anti-short cycle delay, set back, offset, alarms and more. It includes an NTC (Negative Temperature Coefficient) thermistor temperature sensor, and can be used with certain other NTC or PTC (Positive Temperature Coefficient) thermistors that meet the specified resistance vs. temperature specifications. See the tables on page 7.

The control can fit many applications, which range from refrigeration to heating due to the wide temperature range of the control stated above. Typical applications include walk-in freezers, beverage coolers, supermarket display cases for flowers, produce, meats, convenience store refrigerated cases, food warmers, boiler control, and certain industrial applications.



PRECAUTIONS

⚠ WARNING

- Failure to read and follow all instructions carefully before installing or operating this control could cause personal injury and/or property damage.
- To prevent electrical shock, personal injury and/or equipment damage, disconnect electric power to system at main fuse or circuit breaker box prior to installation or service.
- To prevent scald injury, do not use this control to heat water for bathing, washing, hot tub or similar applications.
- Where failure of this control may result in personal injury and/or property damage, additional alarms or limit controls must be installed.
- This control is a temperature control and is not to be used as a temperature limit control.

CONTENTS

Basic Description	1
Precautions	1
Installation	2
Wiring	3
User Menu	4
Operation	5
Specifications	7
Troubleshooting	8

16E09-101 Optional Accessories / Service Items:

Immersion Well	F89-0286
Replacement 7.5' NTC Remote Sensor	F136-0114
Well Heat Transfer Compound	F145-0163

INSTALLATION

- ⚠ **To prevent electrical shock and/or equipment damage, disconnect electric power to system at main fuse or circuit breaker box prior to installation or service.**
- ⚠ **Where failure of this control may result in personal injury and/or property damage, additional alarms or limit controls must be installed.**
- ⚠ **This control is a temperature control and is not to be used as a temperature limit control.**

The control has a user selection for changing the setpoint to be either the Cut In or the Cut Out setting. The user must be careful to understand how this effects the "range" in which the control will operate when the differential value is entered. If entered values are incorrect, the control could operate outside the user's intended settings due to set-up error. See section titled "Operation".

Fig. 1 Control Front View and Description

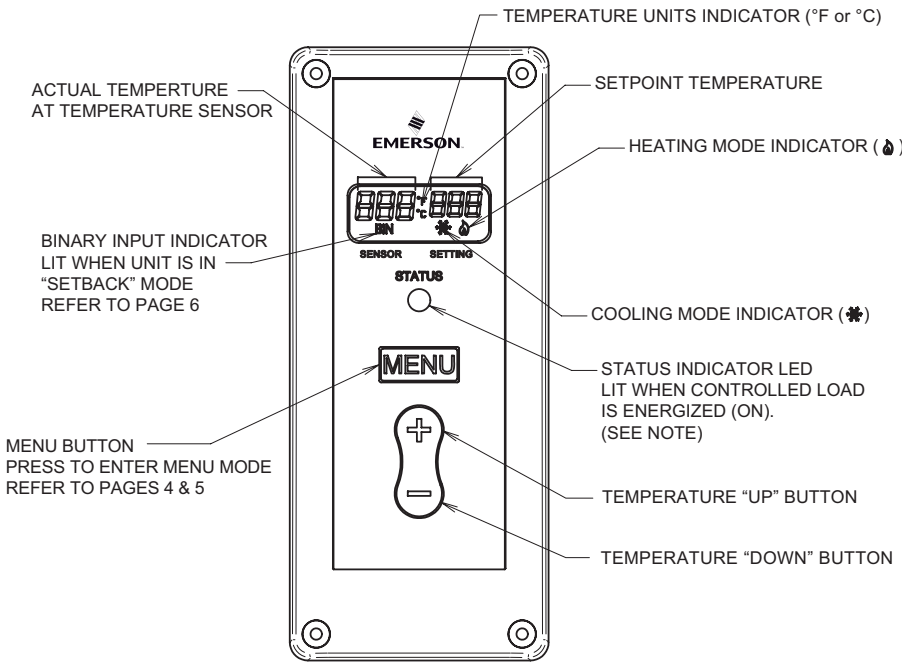

Circuit Board Inside Cover

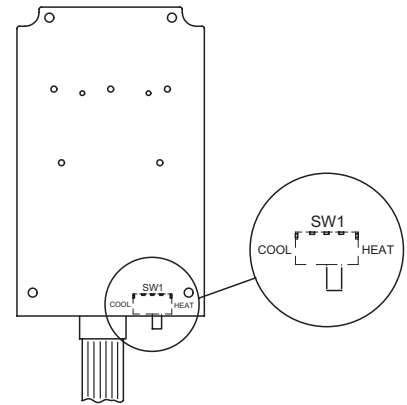

Switch SW1 must be set for system mode as shown:

	SW1
Refrigeration	Cool
Heating	Heat

NOTE:

Green Status Indicator LED and display backlight operation

It may be observed from time to time that the green status indicator LED and display back-light will briefly turn off during a call for heating or cooling. During this time, the control is performing a self-check lasting up to 15 seconds. This is normal operation of the control and the load power will be maintained

Fig. 2 Control Dimensions and Mounting Information

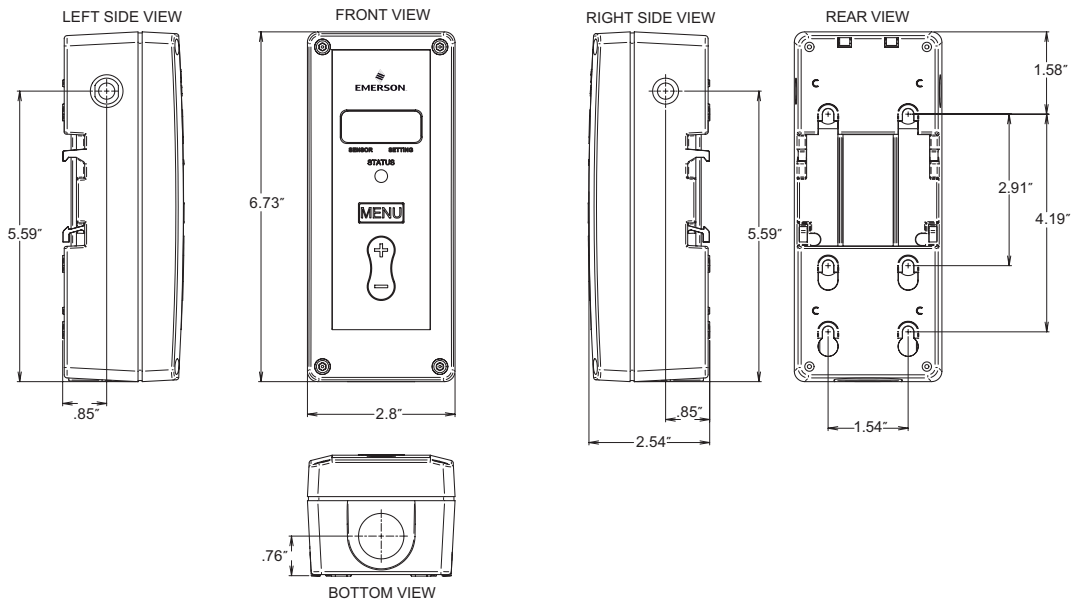

WIRING

Wiring Instruction Notes

Switch Settings

Switch SW2 must be set for applications as shown:

	SW2
Line Voltage (Power Stealing)	PS
Line Voltage (Non Power Stealing)	Non PS
24 VAC (Non Power Stealing)	Non PS

Power Stealing

Power Stealing is an electronic design within the control that can eliminate the need to connect a neutral line to power the control. The control receives power from the unit it is controlling. Power Stealing saves time and money by often eliminating the labor to run a neutral wire to the control for power. See compatibility chart below for certain limitations.

Power Stealing Compatibility Chart

Application	Power Stealing	Non-Power Stealing
Line Voltage, replacing existing control that has a common wire	Yes	Yes
Line Voltage, with load greater than 2.5 amps, without Defrost timer or other power interruption circuit, with or without alarm	Yes	Yes
Line Voltage, with load greater than 2.5 amps, with Defrost timer or other power interruption circuit, no alarm	See Note 1	Yes
Line Voltage with load greater than 2.5 amps, with Defrost timer or other power Interruption circuit, with alarm	No	Yes
Line Voltage with load less than 2.5 amps	No	Yes
24 VAC Application	No	Yes

NOTE 1: During defrost or time when load circuit is broke, display will be blank because power has been interrupted to the control. All menu settings and setpoint will be restored when power is returned.

* NTC – Negative Temperature Coefficient
PTC – Positive Temperature Coefficient

NOTE: Only one sensor (PTC or NTC) may be connected. Sensor must meet specific temperature vs. resistance specifications.

Fig. 3 Line Voltage Application (Power Stealing)

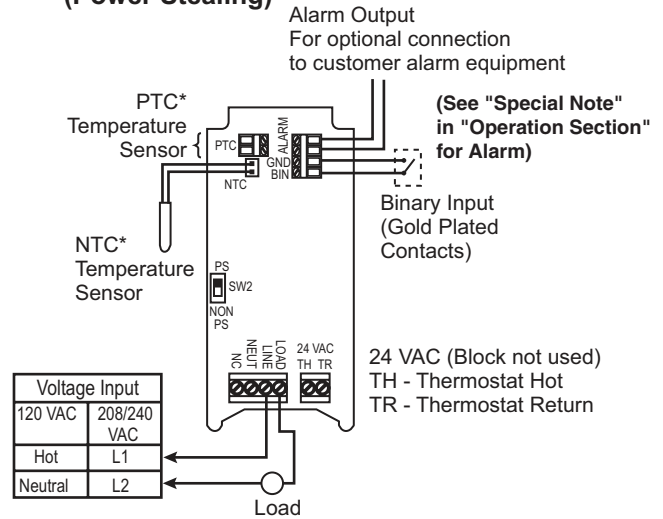

Fig. 4 Line Voltage Application (Non-Power Stealing)

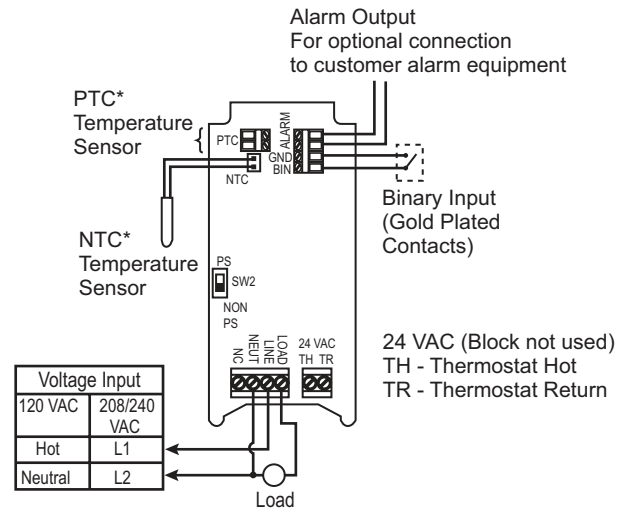
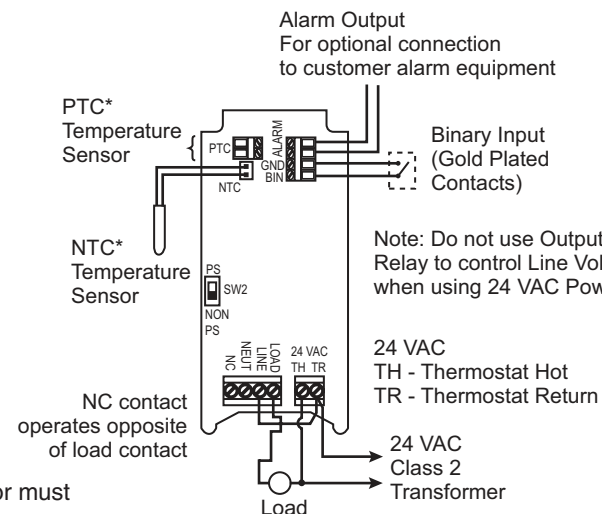





Fig. 5 24 VAC Applications (Non-Power Stealing)



USER MENU

USER MENU OPERATION SETTINGS:

The control has user Menu settings that will determine how the control operates. The unit is shipped with factory default settings. The user must change any of the settings as required for the application. To reset all settings to factory defaults, press and hold all 3 buttons simultaneously (MENU, , and ) for approximately 5 seconds.

To view Menu items, press and hold MENU for 5 seconds. The unit will display the first Menu item on the left side of the display. The right side of the display indicates the Menu item settings. To change the setting, momentarily press the  or  key.



A momentary press of the MENU key advances the display to the next Menu item, and continues, till the last menu item is displayed. Pressing the key one more time with the **last** menu item, (aL) displayed returns the control to the operating mode.

Each press of MENU results in forward movement to the next Menu item. If you need to change an item “passed”, you must repeatedly press MENU, return to the operating mode, then press and hold MENU for 5 seconds to re-enter the Menu mode. Then repeatedly, momentarily press MENU until the desired Menu item is again displayed.

To store any changes made to any Menu items, the Menu must be exited by pressing MENU when the last item is displayed. If no buttons are pressed for ten minutes while in the menu, the control will return to operating mode and any changes that were made will be lost.

The following table shows the menu items, default settings and optional settings.

NOTE: The Heat/ Cool switch (SW1) MUST be in the proper position BEFORE setting options.

Menu Item	Description	Factory Default	Options Press  or  to select	Comments
CF	Temperature Scale	F	C or F	Selects temperature display in Fahrenheit or Celsius
dFF	Differential	5	1 to 30	Selects the range between Cut In and Cut Out.
SP	Set Point Mode Cool Heat	CI CO	CO or CI CI or CO	Selects how the set point temperature will operate the load terminal. CI indicates the setpoint temperature will be the Cut In temperature. CO indicates the temperature will be the Cut Out temperature. See Operation section.
SOF	Sensor Operation Failure Cool Heat	1 0	0 or 1 None	Cooling - Selects the operation of the Control Load relay in the event of a sensor failure in Cool mode. 1 (default) will cause the load contacts of the relay to close and remain closed if the sensor either opens or shorts. 0 causes the load contacts of the relay to open and remain open. Heating has no optional selection. Sensor failure in Heating will result in the relay contacts opening.
dL	Display Light	Off	On or Off	Selects the LCD display light Off or On. With this selected Off, the display light will illuminate any time a keypad button is pressed to provide better viewing in low lighting conditions, and go off after 10 seconds. If On is selected, the display light will be On continuously.
ASd	Anti Short-Cycle Delay	Cool 1 Heat 0	0 to 12	Selects the minimum time (in minutes) that the load contacts will remain open after a cycle before closing again. This will prevent the compressor or other load from being damaged by cycling too soon. A blinking Snowflake or Flame icon indicates that the control has a demand to energize the load, but is waiting for the delay time to elapse. A setting of 0 indicates no time and the feature is disabled. SW1 must be set to the proper position before checking this setting.
LP	Lock Front Panel Keypad	Off	On or Off	When selected Off, the keypad can be used as normal. When selected On, prevents unauthorized access to the control settings by locking out all keys. To unlock the control when it is locked, press and hold the Menu key for 5 seconds.
OFS	Ambient Temperature Offset	0	-4, -3, -2, -1, 0, 1, 2, 3, 4	This control is calibrated at the factory, but the “sensed” temperature may read different because of mounting/installation, or other factors. This item allows the displayed temperature to be shifted the number of degrees set to compensate for this difference

USER MENU

Menu Item	Description	Factory Default	Options Press \oplus or \ominus to select	Comments
bln	Binary Input	Off	On or Off	The default setting of Off will have no affect on the operation of the thermostat. When set to On, it allows an external binary input (switch or relay) to start a temperature set back. See Set Back (Sb).
Sb	Set Back	0	0 to 50	Selects the number of degrees the thermostat will change the setpoint temperature when the external binary input signal is received. 0 will cause no temperature change to occur. See Binary Input (bin).
AL	Alarm	0	0 to 99	Selects the time delay (in minutes) before a Temperature Out of Range alarm output is sent. A setting of 0 disables the alarm relay.

OPERATION

! This control is a temperature control and is not to be used as a temperature limit control.

! To prevent scald injury, do not use this control to heat water for bathing, washing, hot tub or similar applications.

The factory default setpoint for this control is 45°F (7°C) for Cool and 120°F (49°C) for Heat. Setpoint temperature can be adjusted using the \oplus or \ominus keys. A power loss does not lose the settings. All menu item selections and setpoint setting are stored in a permanent memory.

The user determines the temperature operating range. To determine the temperature range, the user must select the Set Point (SP) as the Cut Out or Cut In temperature, Differential (dFF) and enter a set point temperature. Cut out is when the load is turned off and cut in is when the load is turned on.

NOTE: The Heat/ Cool switch (SW1) MUST be in the proper position BEFORE setting options.

COOL/REFRIGERATION

To use as a Cooling control, SW1 must be set to Cool. The snowflake (❄) icon will display.

If control is in Cool mode, and Set Point is selected as the Cut In:

$$\text{Temperature Operating Range} = \text{Setpoint Temperature} - \text{Differential (minus)}$$

Example:

SW1 = Cool
Set Point (SP) = Cut In
Differential = 5
Setpoint temperature = 40°

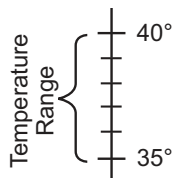

If control is in Cool mode, and Set Point is selected as the Cut Out:

$$\text{Temperature Operating Range} = \text{Setpoint Temperature} + \text{Differential (plus)}$$

Example:

SW1 = Cool
Set Point (SP) = Cut Out
Differential = 5
Setpoint temperature = 40°

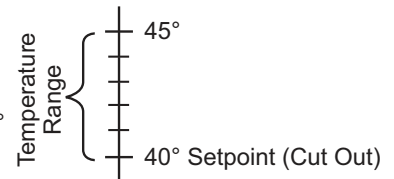

HEAT

To use as a Heating control, SW1 must be set to Heat. The flame (🔥) icon will display.

If control is in Heat mode, and Set Point is selected as the Cut Out:

$$\text{Temperature Operating Range} = \text{Setpoint Temperature} - \text{Differential (minus)}$$

Example:

SW1 = Heat
Set Point (SP) = Cut Out
Differential = 5
Setpoint temperature = 100°

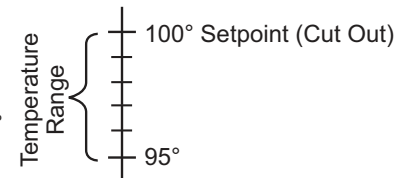

If control is in Heat mode, and Set Point is selected as the Cut In:

$$\text{Temperature Operating Range} = \text{Setpoint Temperature} + \text{Differential (plus)}$$

Example:

SW1 = Heat
Set Point (SP) = Cut In
Differential = 5
Setpoint temperature = 100°

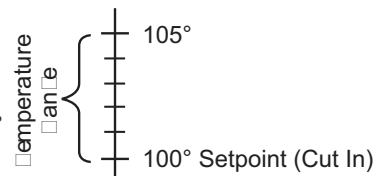

OPERATION

Lock Panel (LP)

The keypad can be locked to prevent unwanted tampering with the control settings. In the User Menu, change the menu item LP selection to On. When the menu is exited and settings are stored, the \uparrow or \leftarrow , and **MENU** keys will be disabled from normal use.

To unlock the keypad, press and hold **MENU** for 5 seconds. The display will change to show LP On. Momentarily press \uparrow or \leftarrow to change to Off and then momentarily press **MENU**. The control will return to normal operation and the keypad will be unlocked.

Binary Input (bln) and Set Back (Sb)

Binary Input is an option to allow the setpoint temperature to set back to conserve energy or for other reasons as determined by the user. Set Back determines the number of degrees the setpoint temperature will be changed.

An external switch or N.O. relay can be connected to the BIN and GND terminals of the control. With bln set to On, when the switch is closed, the control will change the setpoint temperature by the number of degrees set in Sb. In Heat mode, setpoint temperature will change lower or cooler. In Cool mode, setpoint temperature will change higher or warmer.

During the time that the switch is closed, bln will appear in the lower left corner of the display. If an alarm is connected be sure that the alarm delay time is set long enough to allow for the temperature change to avoid a “false” alarm.

Alarm (AL)

SPECIAL NOTE

Using the Alarm Output and power stealing in combination

– When using power stealing mode and the alarm output, it is important for the installer to review the wiring circuit of the installation to insure no device is present that could interrupt electrical power to the temperature control. Such a device could be a defrost timer, as one example, that may be used in some refrigeration applications.

If a device is in the system wiring that can periodically disrupt power to the load and the temperature control, the power stealing mode of the control cannot be used. A neutral wire must be connected to the control and select the non power stealing mode for the control. This keeps power to the control during power interruptions to the load and avoids a “false” alarm output.

This control has an alarm relay that will provide an output to alert of a malfunction. The alarm relay output must be connected to an external light, audible alarm or other device as needed by the user. If AL is set to 0, the alarm relay will not provide any alarm output. If AL is set to a value greater than 0, the alarm relay output provides indication of three error conditions: Temperature Out of Range, Power Loss and Sensor Operation Failure. Although AL must be set to a value greater than 0 for any alarm output to be provided, the value selected is the time delay, in minutes, before a Temperature Out of Range alarm is set. The alarm time delay does not apply to Power Loss or Sensor Operation Failure.

Temperature out of range – If the temperature is more than 5° from the setpoint, continuously for the length of time set in AL, the alarm relay output will close. The delay should be set to allow for conditions that will cause the temperature to vary, such as defrost cycle, opening door for stock removal or replacement or Set Back changes. When setting the AL time, consideration should be given to these events to prevent a false alarm.

If the control set back feature is used to change the setpoint, the delay period set in AL should consider the time it takes for the system to reach the set back temperature to avoid a false alarm.

Power Loss – If the temperature control experiences an input power failure, the control will close the alarm relay before total power of the control is lost. The delay time is not used in this event, and the alarm relay will close within seconds of a power failure. In addition, the load relay contact change state per the Sensor Operation Failure (SOF) setting.

When power returns, the alarm contacts will open. The load relay will remain in the SOF position the length of time set in Anti Short-Cycle Delay (ASd) after power resumption. The display will blink the flame or snowflake icon for this time to indicate the load is “locked” out. This is to help protect the user’s equipment from damage by short cycle switching.

Sensor Operation Failure (SOF) – If in operation, the sensor wiring should become open or shorted, the temperature control will begin blinking SOF with SH for shorted or SO for sensor open. However, the control will wait approximately 1 minute before closing the alarm output relay - indicating sensor operation failure. If during the 1 minute, the sensor “resumes” normal operation, the time is reset and the control returns to normal display. The load relay will operate as selected in sensor operation failure (SOF).

Multiple Sensors

The 16E09 is normally operated with one sensor. If an average temperature of an area is required, 4 sensors may be used and wired in the method shown below. If 4 sensors are used, they must all be of the same model.

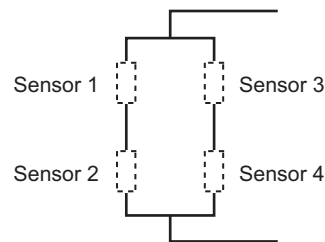

NOTE: When using multiple sensors, 4 sensors must be used. The control will not operate with 2 or 3 sensors.

SPECIFICATIONS

Load Output Relay:

	Ratings (Maximum):		
	120VAC	208VAC	240VAC
Full Load Amps NC & Load	16 A	9.2 A	8 A
Locked Rotor Amps NC & Load	96 A	55.2 A	48 A
Non-Inductive Amps NC & Load	16 A	16 A	16 A
Horsepower NC & Load	1 hp	1 hp	1 hp

24 VAC NC & Load 100 VA, 30 VAC Max (Class 2)

Pilot Duty NC & Load 125 VA, 24 to 240 VAC

- Minimum Load Rating: 1 Amp @ 24 VAC
- Note: the above minimum current/voltage is specified to assure proper operation.

NOTE: For use on single phase circuits only.

Alarm Relay Ratings (Maximum):

N.O. contact: 1 Amp, 5 to 24 V, AC or DC

Temperature Probes:

NTC

The control is shipped with an NTC (Negative Temperature Coefficient) sensor, with a cable length of 7½ feet. Cable length can be extended up to 400 feet by appropriately splicing and adding additional cable (22 AWG or larger diameter)

Operating Ambient Ratings (Control Enclosure):

Operating Temperature: -29°F to 140°F (-34° to 60°C)

Storage Shipping Ambient Ratings:

Storage Temperature: -40°F to 185°F (-40° to 85°C)

Operating Humidity: 0 to 95% Relative Humidity, Non-Condensing

Maximum Dew Point: 85°F (29°C)

Temperature Set-Point Range:

Set-Point Range: -40° to 220°F (-40° to 104°C)

Differential Range: 1 to 30 (Degrees F or Degrees C)

Case:

NEMA 1 Enclosure, Flammability Rating: UL94V0

as needed – polarity is not important. When extending cable length, verify temperature accuracy and use the menu Ambient Temperature Offset (OFS) settings to compensate accordingly if required.

NTC TEMPERATURE VERSUS RESISTANCE TABLES

Temperature (°F)	Temperature (°C)	Resistance (KΩ)
-40	-40	328.29
-31	-35	236.83
-22	-30	172.90
-13	-25	127.65
-4	-20	95.23
5	-15	71.74
14	-10	54.56
23	-5	41.85
32	0	32.37
41	5	25.23

Temperature (°F)	Temperature (°C)	Resistance (KΩ)
50	10	19.82
59	15	15.67
68	20	12.48
77	25	10.00
86	30	8.07
95	35	6.55
104	40	5.34
113	45	4.38
122	50	3.61
131	55	2.99

Temperature (°F)	Temperature (°C)	Resistance (KΩ)
140	60	2.49
149	65	2.09
158	70	1.76
167	75	1.48
176	80	1.26
185	85	1.07
194	90	0.92
203	95	0.79
212	100	0.68
221	105	0.59

PTC

The control may be connected to an existing PTC (Positive Temperature Coefficient) sensor. Make sure the PTC sensor meets the specifications tables below. Failure to do so will result in temperature inaccuracies. The PTC input may not be

extended more than 50 feet, and the wire gauge should be 18 AWG wire or larger diameter. Be sure the probe attached matches the resistance vs. temperature tables or temperature inaccuracies may occur.

PTC TEMPERATURE VERSUS RESISTANCE TABLES

Temperature (°F)	Temperature (°C)	Resistance (KΩ)
-40	-40	613
-31	-35	640
-22	-30	668
-13	-25	697
-4	-20	727
5	-15	758
14	-10	789
23	-5	822
32	0	855
41	5	889

Temperature (°F)	Temperature (°C)	Resistance (KΩ)
50	10	924
59	15	960
68	20	997
77	25	1035
86	30	1074
95	35	1113
104	40	1153
113	45	1194
122	50	1236
131	55	1279

Temperature (°F)	Temperature (°C)	Resistance (KΩ)
140	60	1323
149	65	1368
158	70	1413
167	75	1459
176	80	1506
185	85	1554
194	90	1602
203	95	1652
212	100	1702
221	105	1753

TROUBLESHOOTING

LCD display, display back-light and green status indicator LED turn off in Power Stealing mode:

This "off" condition is normal for the control in power stealing mode when wired with a defrost timer or other device that interrupts electrical power to the control.

No control settings will be lost during this time, however, the installer must ensure that applications requiring power stealing are suitable for the control to be off during these periods.

Please note: if the built-in alarm feature of the control is to be used on systems that may interrupt power to the control, the control must be wired with a neutral wire and set in non-power stealing mode. This will keep the control continuously powered unless there is an actual power interruption or loss. In this case, the control will be able to signal an alarm for system power loss.

Display indicates "CaL" on power up.

Control was not calibrated. Return control for replacement.

Unit does not turn on, (LCD does not display anything):

- Check that wiring is correct.
- Make sure power is turned on.
- Check that wiring is under terminal blocks correctly.
- Make sure both switches inside control are set to proper position.
- If in Power Steal mode,
 - Make sure the load draws a minimum of 2.5 amp AC. If not, wire per the Non-Power Stealing diagram.
 - Make sure nothing "breaks/opens the load line, such as a defrost timer or any other device, with the alarm feature enabled. This would cause a false alarm. If the alarm function is enabled, wire per the Non-Power Stealing diagram.

Temperature differential is wider than set:

- Temperature change of customer's unit is fast, and the Anti Short Cycle delay setting may be overriding the "call" to activate the heat or cool. Solution – lower Anti Short Cycle delay.

Installation and Power Up:

False alarm sounds, temperature has not yet reached setpoint setting. CUSTOMER must disable alarm (AL = 0), until setpoint temperature is reached, then set alarm delay time.

Customer Changes Setpoint Temperature:

False alarm sounds. CUSTOMER must disable alarm (AL = 0), while unit is adjusting to new temperature. CUSTOMER must then set the alarm delay time when temperature is reached.

Bin/Set Back

False alarm sounds. CUSTOMER must set the delay time with sufficient delay time to assure the Set Back temperature is reached before the alarm delay time has expired.

Note: If the Set Back temperature cannot be reached within 99 minutes (the maximum Alarm delay time), change the Set Back value to a lower number of degrees. If a lower set back can not be used, you may not be able to use the alarm feature.

Alarm Sounds, Reason Unknown:

CUSTOMER should make sure the Alarm (AL) delay time is great enough to cover other conditions when the unit temperature may not be able to stay within 5 degrees.

- Loading or unloading of stock and the doors are open. (Add sufficient delay time to the alarm delay).
- Power is lost to the control if the line is broken/open by a defrost timer or other device. (Wire control per the Non Power Stealing line voltage schematic and connect/add a neutral line connection).

TECH SUPPORT HELP LINE: 1-888-725-9797

White-Rodgers is a division of Emerson Electric Co.

The Emerson logo is a trademark and service mark of Emerson Electric Co.

White
Rodgers[™]

www.white-rodgers.com
www.emerson.com

EMERSON[™]
Climate Technologies