

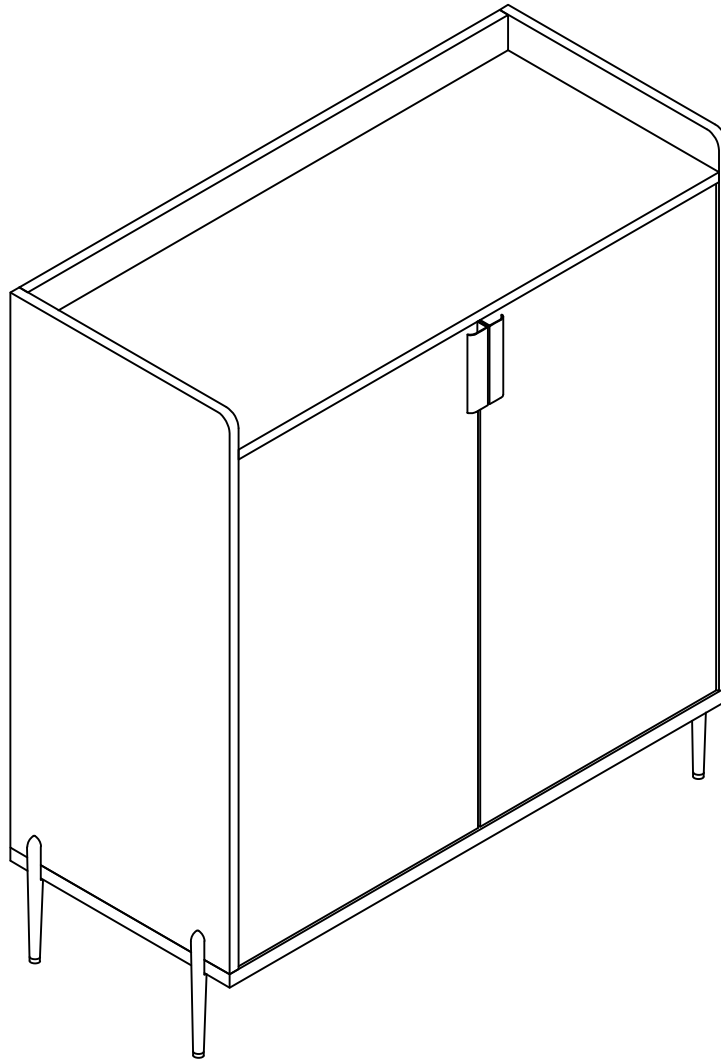

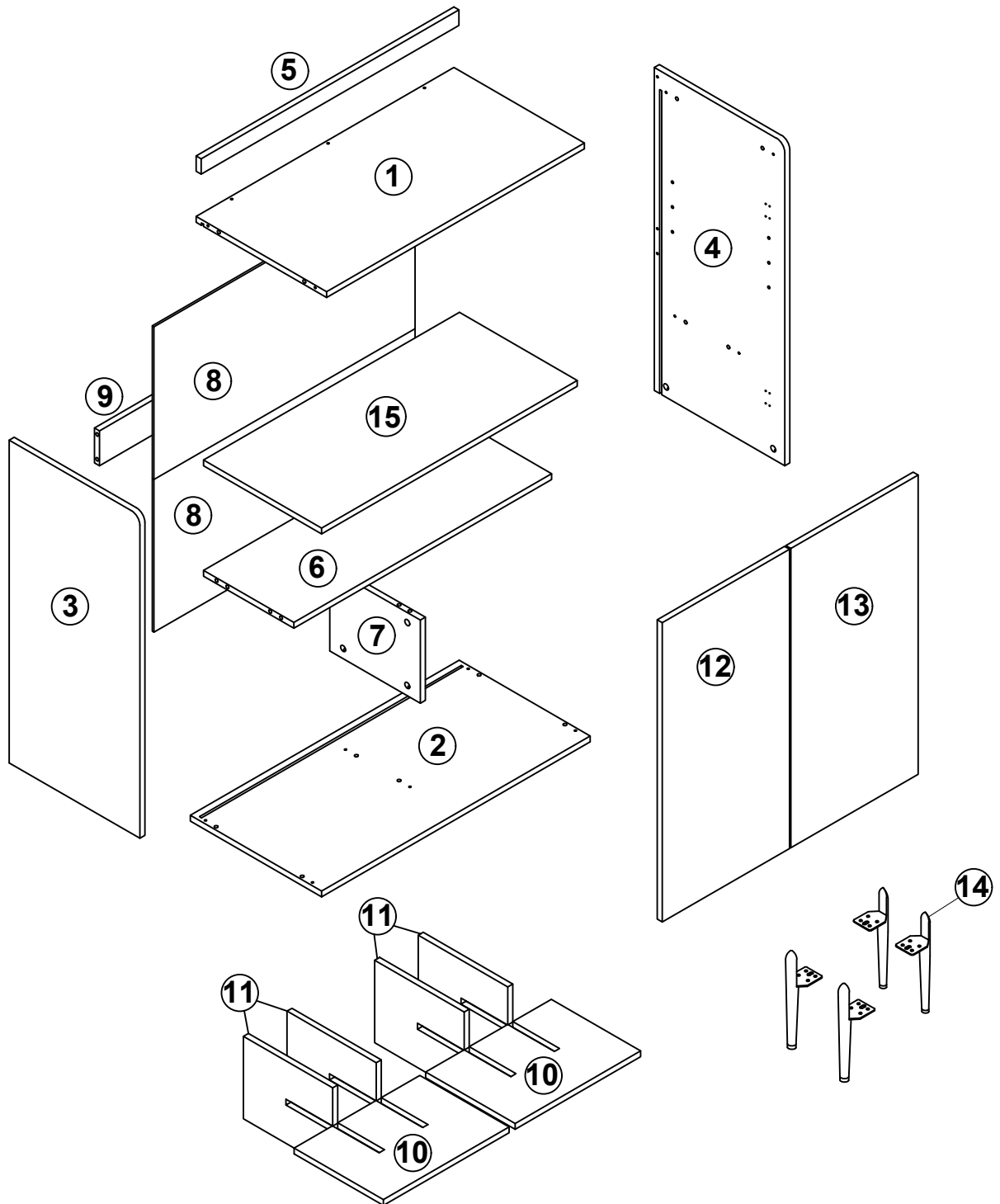





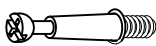

# Assembly Instruction

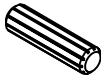

# ASSEMBLY INSTRUCTION

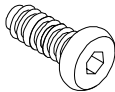

# HARDWARE

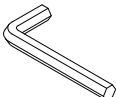
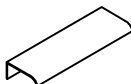
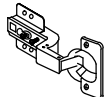
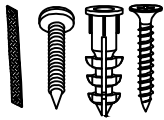
<p>A x 25+2spare</p>  <p>Ø6 x 32mm</p>	<p>B x 25+2spare</p>  <p>Ø15 x 10mm</p>	<p>C x 16+2spare</p>  <p>Ø8*30mm</p>	<p>D x 4+1spare</p>  <p>Ø3*18mm</p>	<p>E x 28+2spare</p>  <p>Ø3.5*12mm</p>
<p>F x 4+1spare</p> 	<p>G x 4+1spare</p> 	<p>H x 25+2spare</p>  <p>Ø20mm</p>	<p>I x 16+2spare</p>  <p>M6*15mm</p>	<p>J x 16+2spare</p>  <p>Ø11*1.5mm</p>
<p>K x 1</p> 	<p>L x 2</p>  <p>120*40 mm</p>	<p>M x 4</p> 	<p>N x 2</p> 	

## ASSEMBLY INSTRUCTION

## Installation of Cams and Pins

Screw the pin into the hole. To set the cams correctly, ensure that the arrow on the cam is opening to the hole of the pin it is locking. Lock the cam by turning the cam head with a screwdriver until it is tightened. Please do not use an electric screwdriver to assemble the unit.

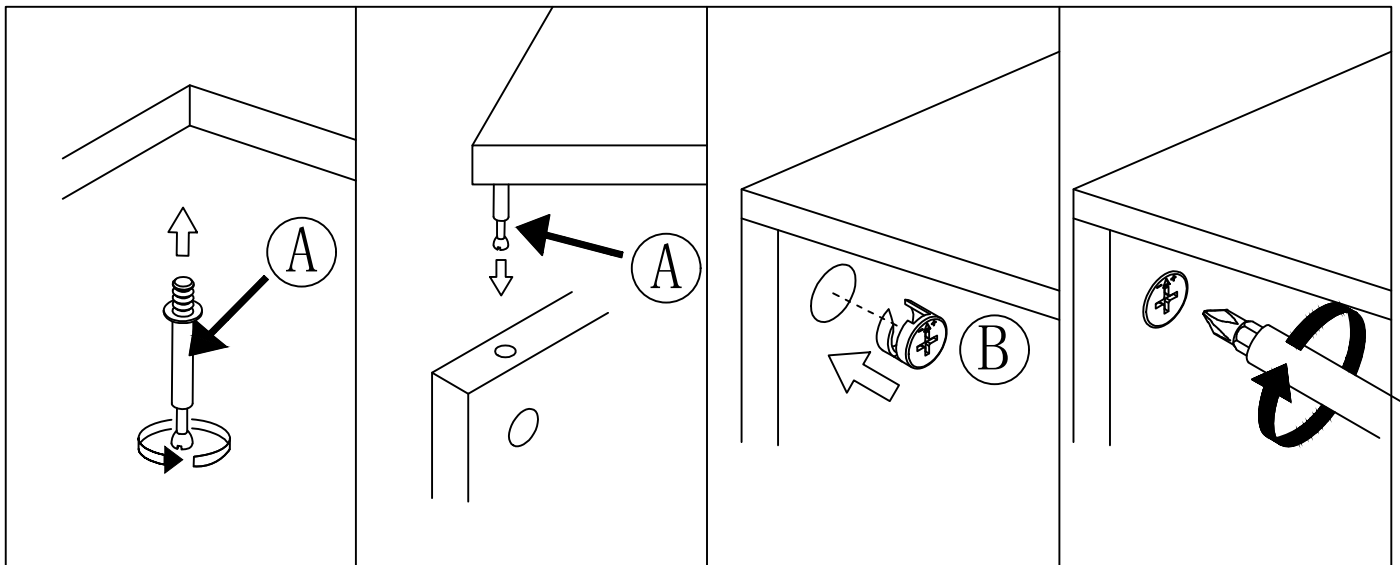

Read each step carefully before starting. It is very important that each step of instruction is performed in the correct order. If these steps are not followed in sequence, assembly difficulties will occur.

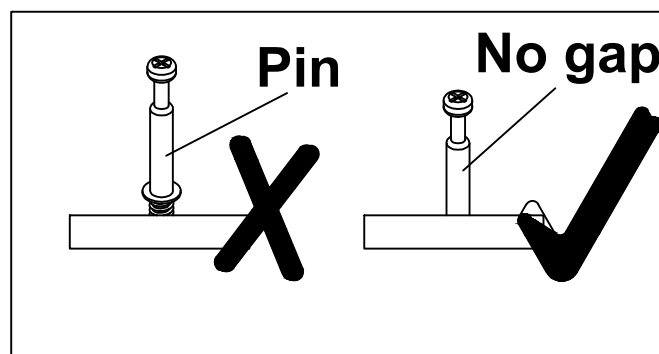

## HING ADJUSTMENT GUIDE

It may be necessary to adjust the hinges so that the doors align. Use the instructions below as a guide.

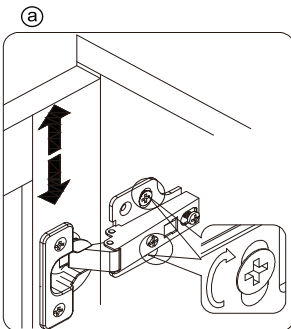

### Up and Down Adjustment

To adjust the door vertically loosen the screw as shown and move up and down as needed.

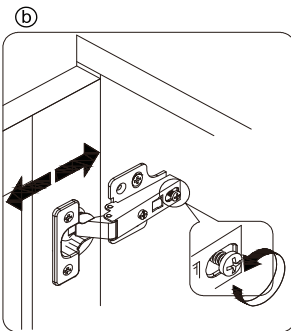

### Front and Back Adjustment

To adjust the gap from the door to the main frame turn the screw clockwise or anti-clockwise as needed.

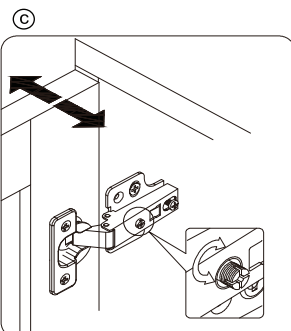

### Left and Right Adjustment

To adjust the door laterally adjust the screw as shown by turning clockwise or anti-clockwise.

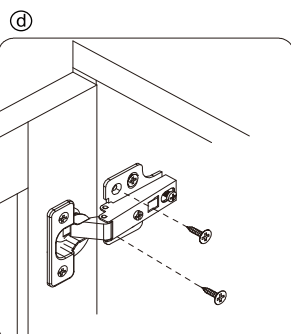

Please fix other screws.

# ASSEMBLY INSTRUCTION

## STEP 1

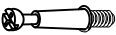
A:  3PCS

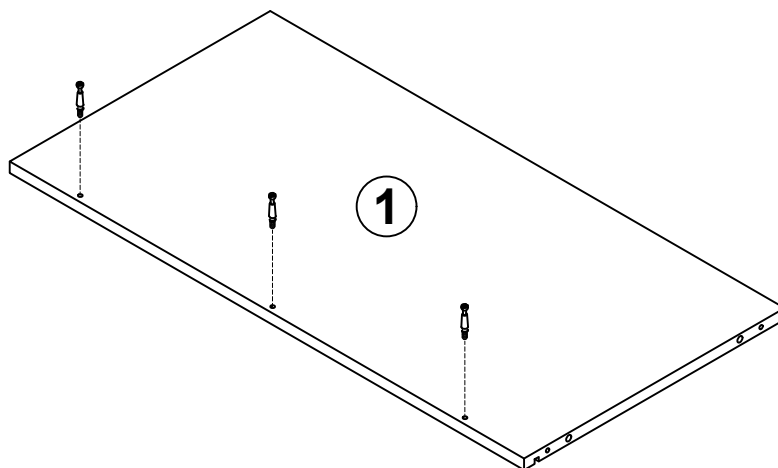

## STEP 2

B:  3PCS

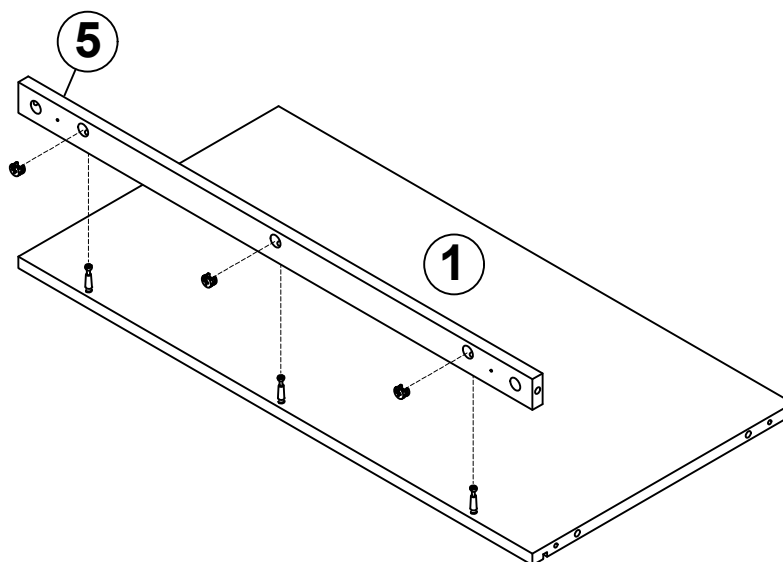

# ASSEMBLY INSTRUCTION

## STEP 3

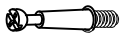
A:  8PCS

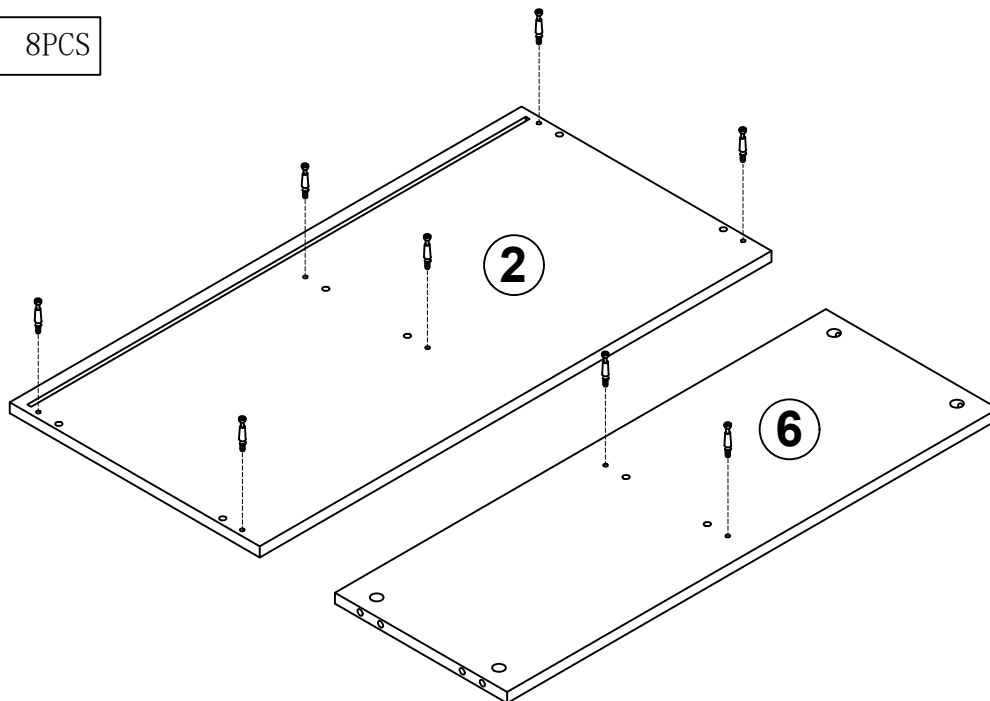

## STEP 4

B:  2PCS

C:  2PCS

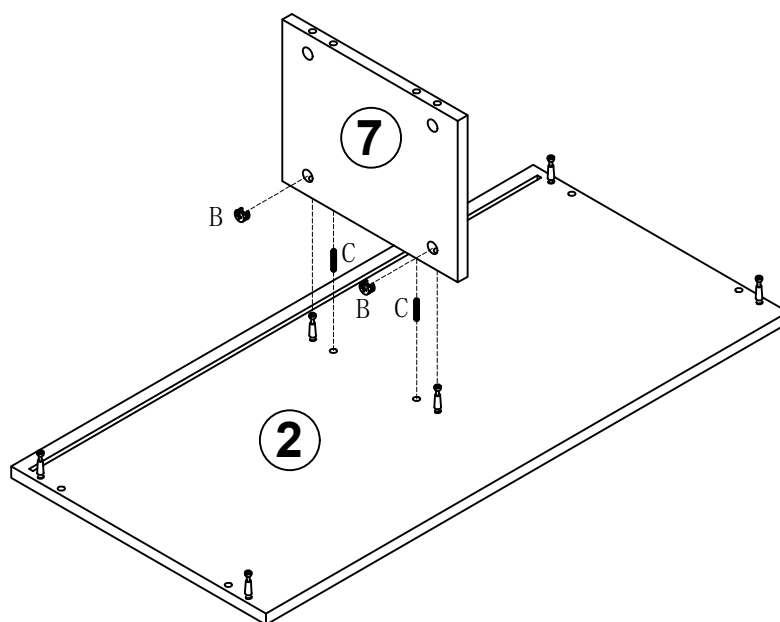

# ASSEMBLY INSTRUCTION

## STEP 5

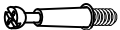
A:  14PCS

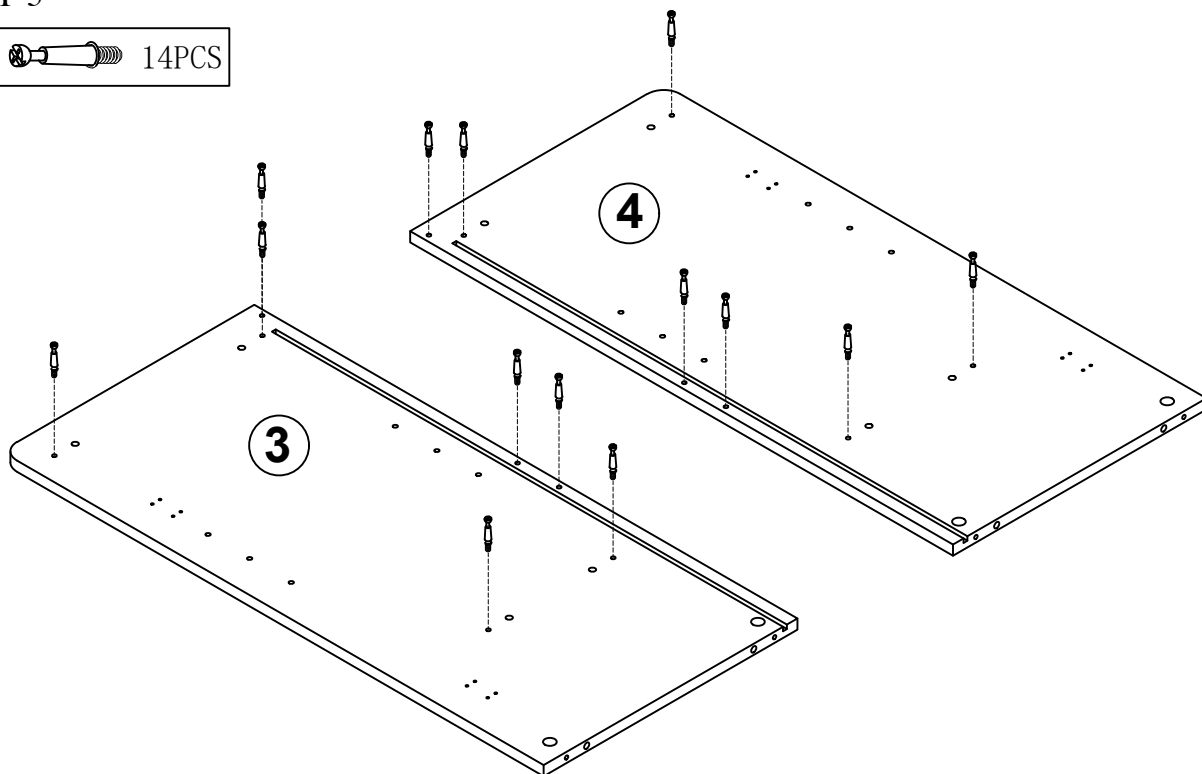

## STEP 6

B:  7PCS

C:  4PCS

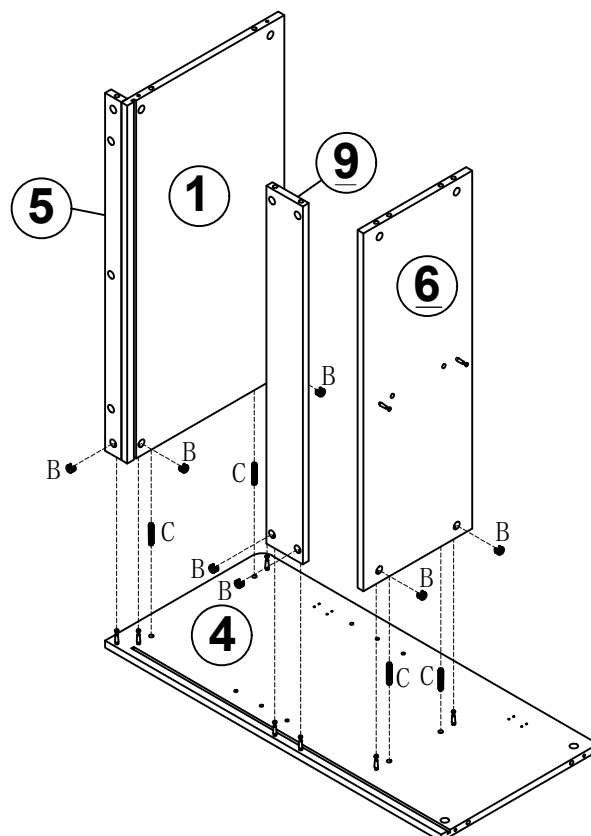

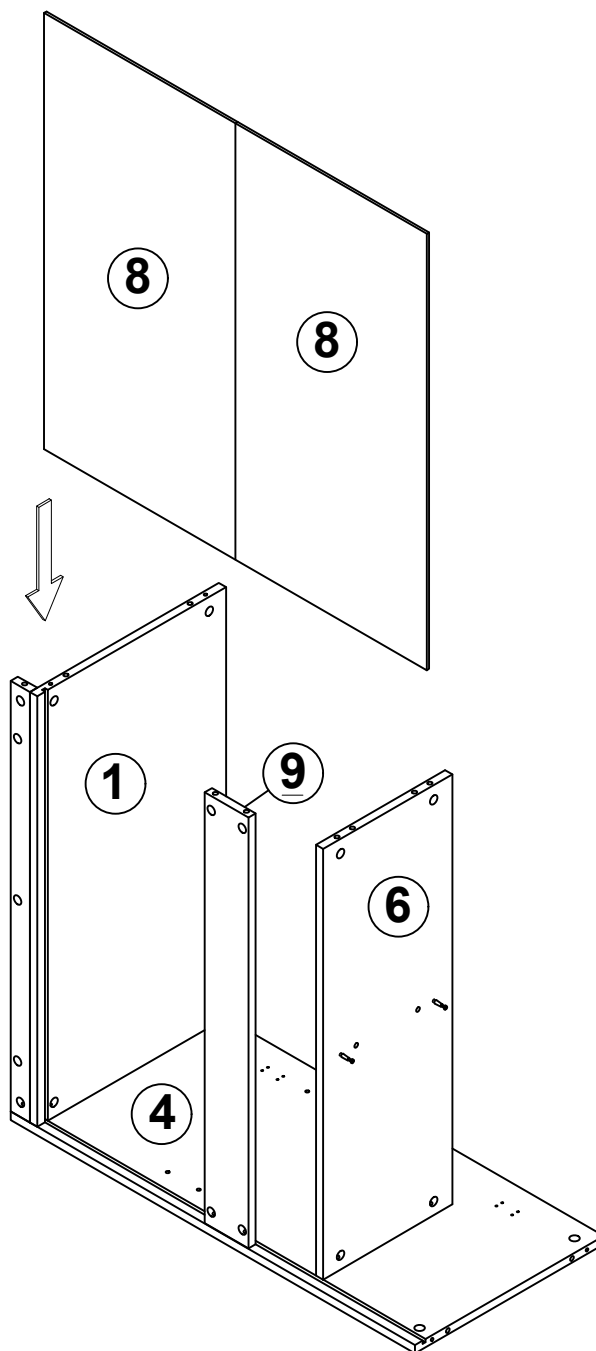

# ASSEMBLY INSTRUCTION

## STEP 7





# ASSEMBLY INSTRUCTION

## STEP 8

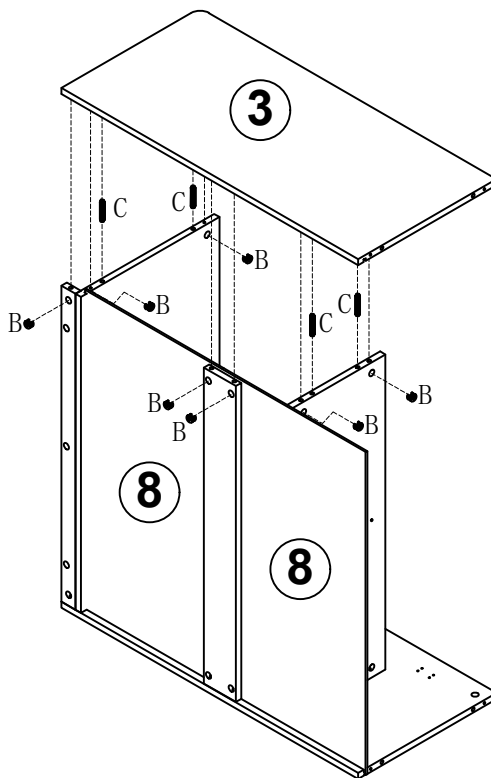
B:		7PCS
C:		4PCS



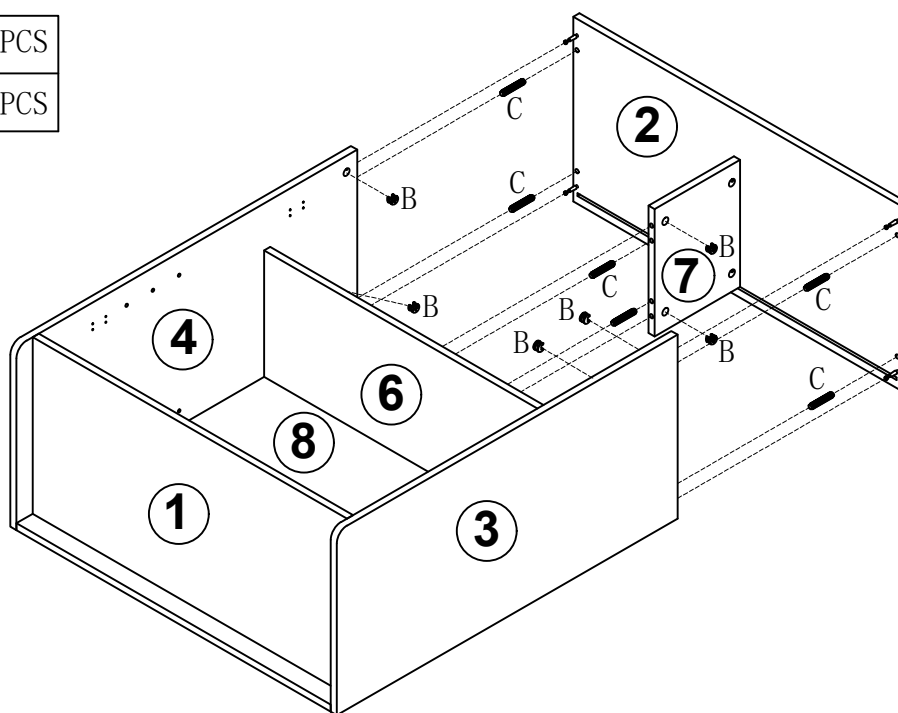

## STEP 9

B:		6PCS
C:		6PCS



# ASSEMBLY INSTRUCTION

## STEP 10

I:		16PCS
J:		16PCS
K:		1PC

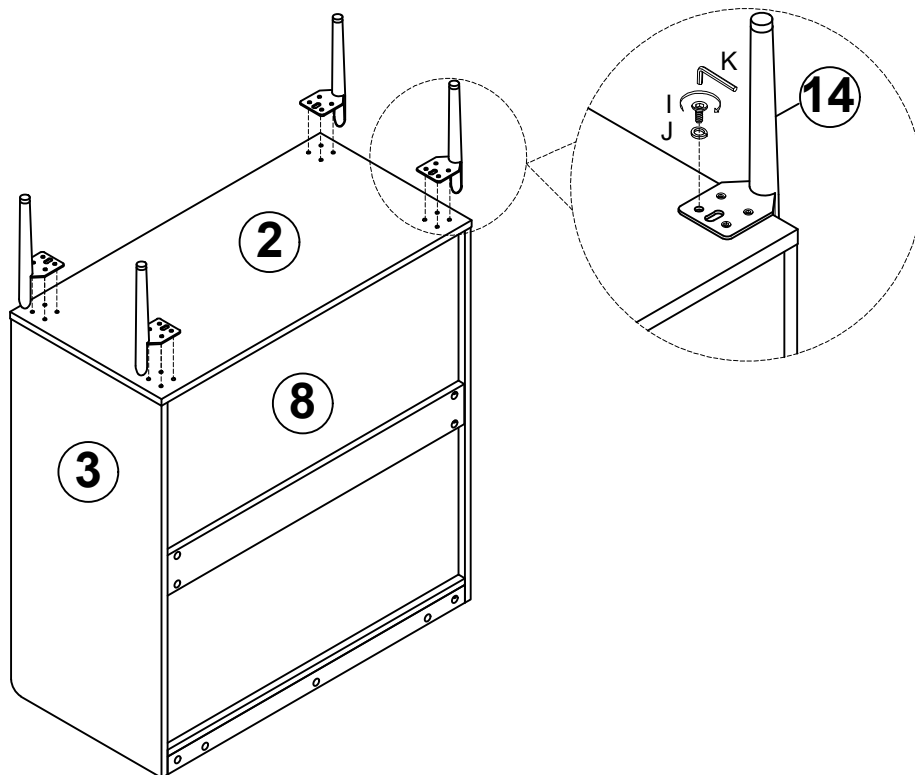

## STEP 11

H:		25PCS
----	---	-------

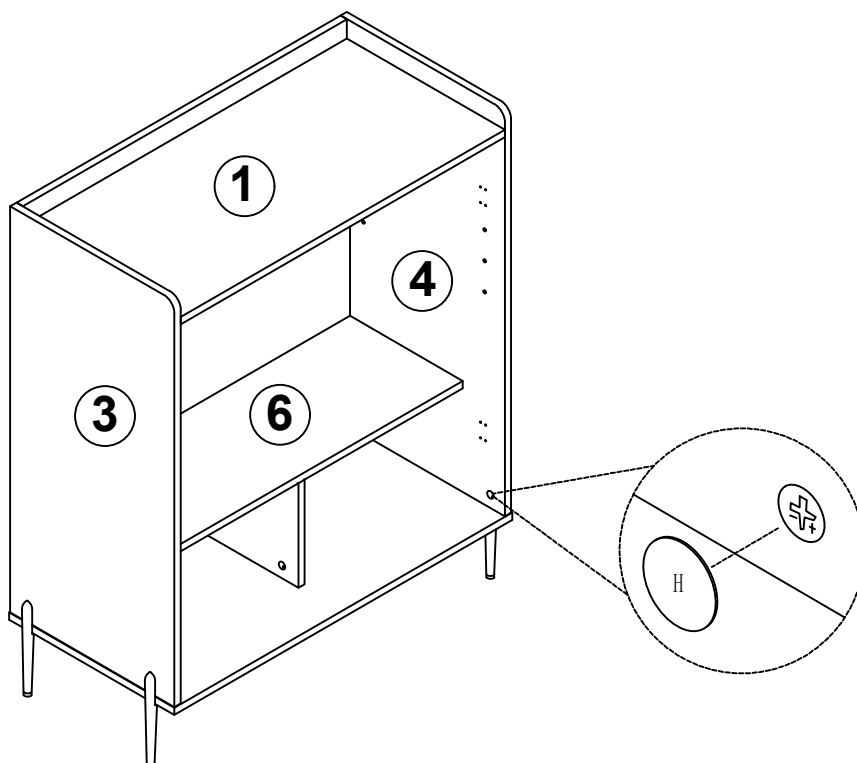

# ASSEMBLY INSTRUCTION

## STEP 12

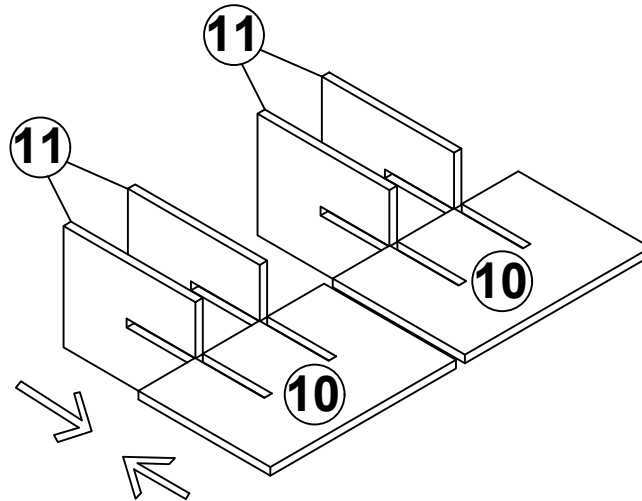

## STEP 13

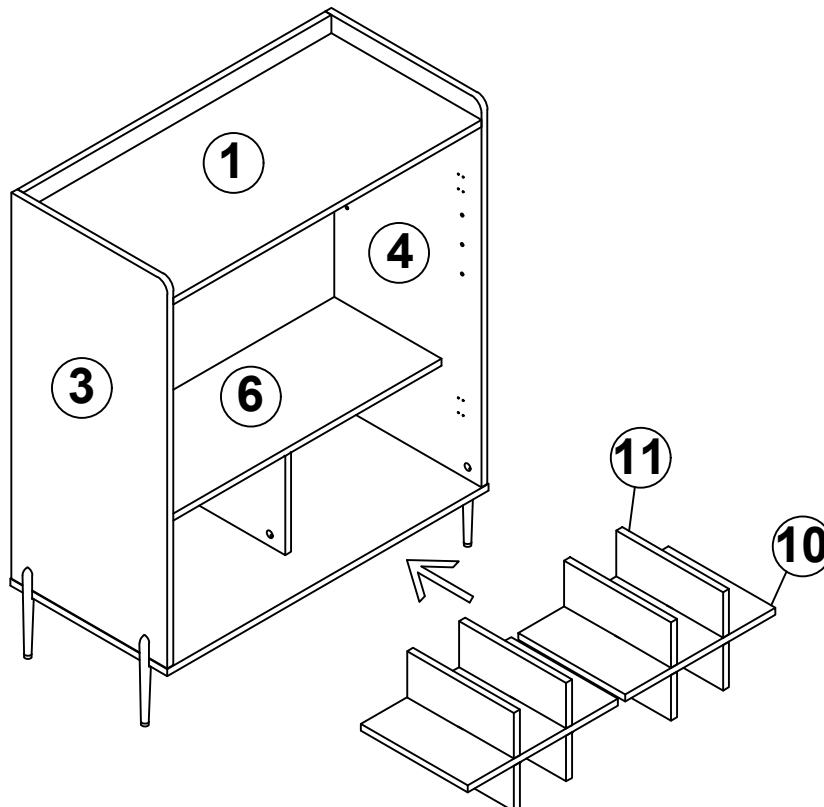

# ASSEMBLY INSTRUCTION

## STEP 14

G:  4PCS

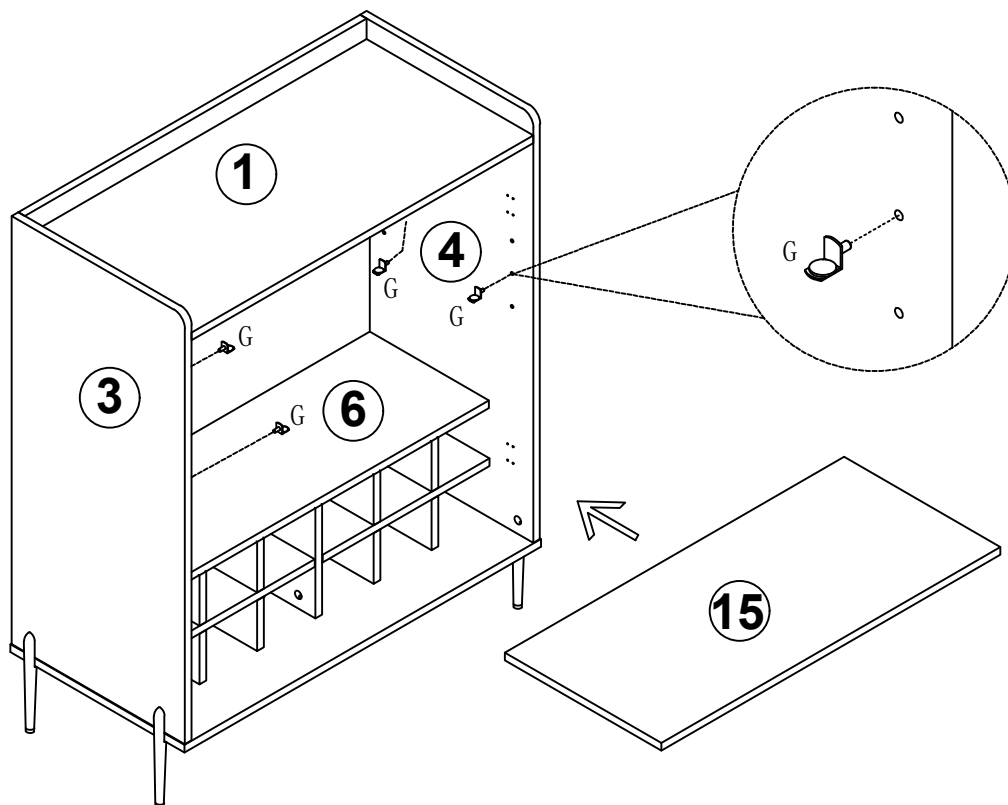

## STEP 15

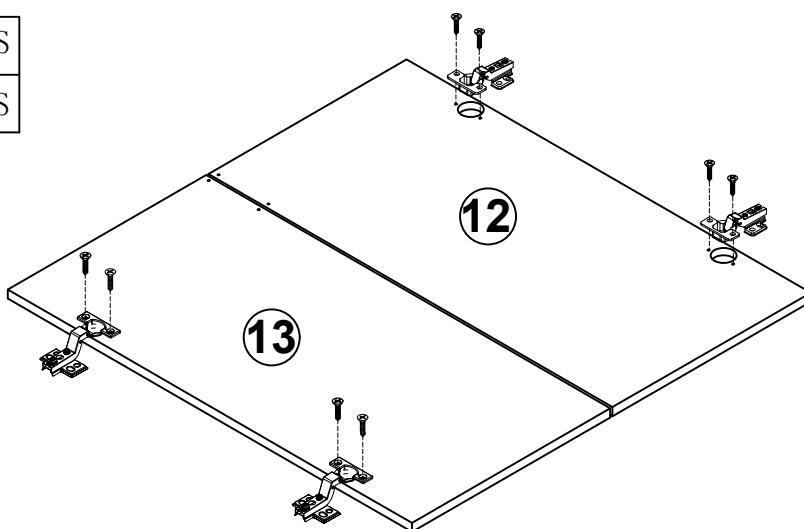

M:  4PCS

E:  8PCS





# ASSEMBLY INSTRUCTION

## STEP 16

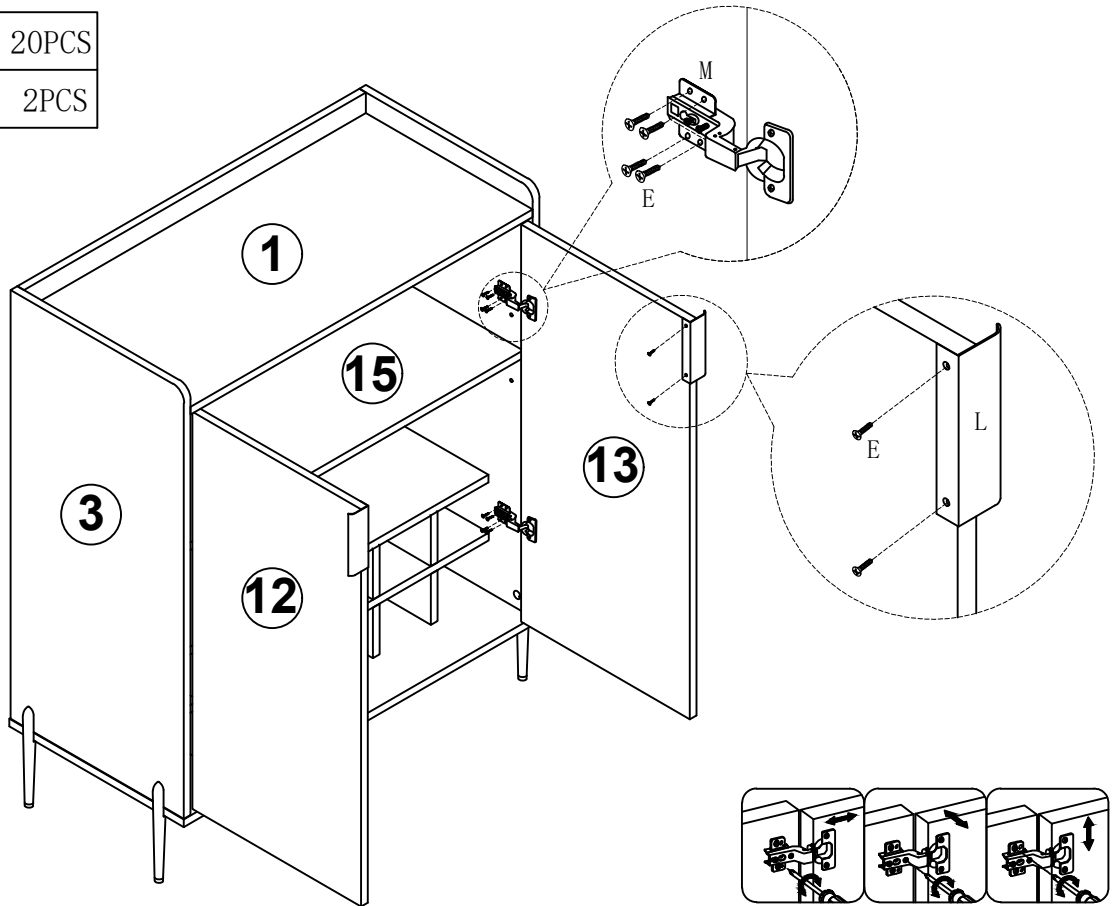
E:		20PCS
L:		2PCS



## STEP 17

D:		4PCS
F:		4PCS

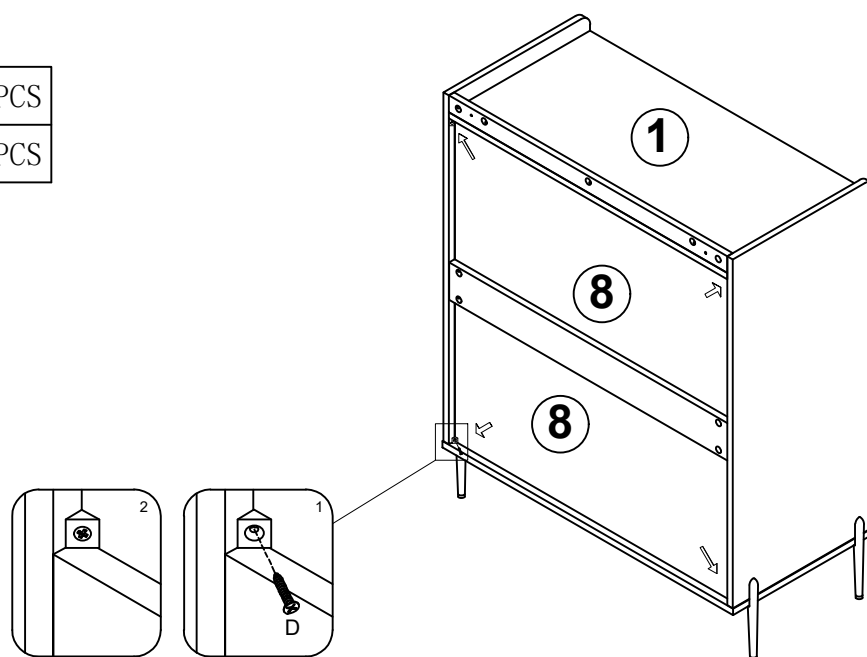

## ASSEMBLY INSTRUCTION

## STEP 18

N x 2

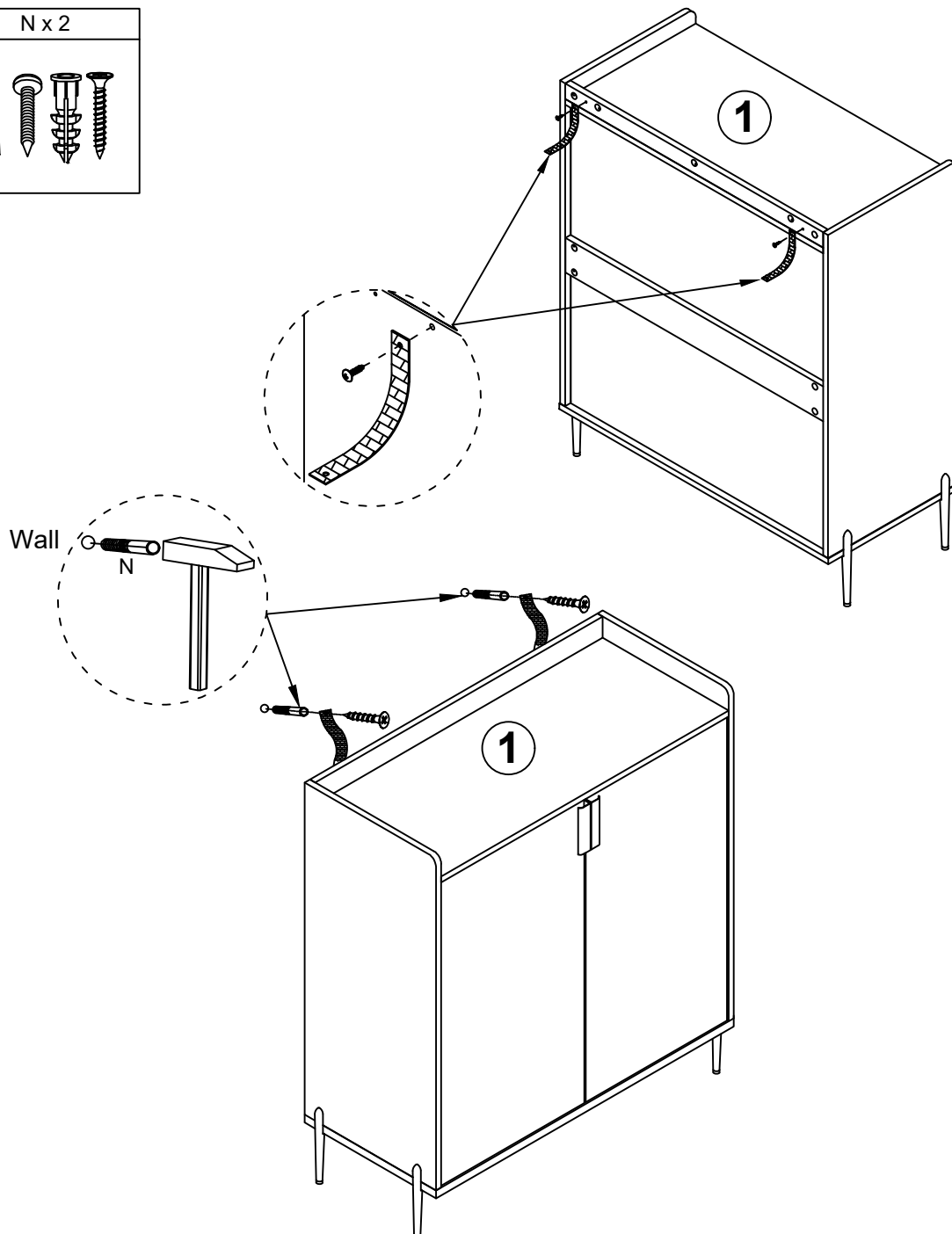
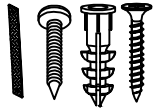

If it is a solid wall, please use expansion and self-tapping screws,  
if it is a wooden wall, only use self-tapping screws,  
please do not overtighten the screws