

easee

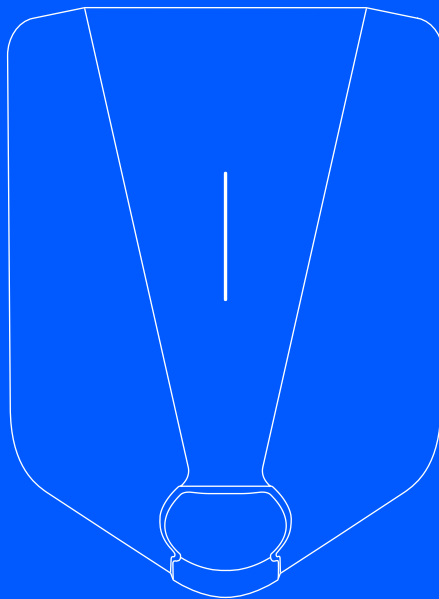

EN Installer guide

Easee Charge Up



Introduction

Read the Important product information guide in the product packaging or at support.easee.com before installing the product.

Installation and operation of the product requires a mobile device with internet connection.

WARNINGS AND CAUTIONS

A Warning indicates a condition, hazard or unsafe practice that can result in serious personal injury or death.

A Caution indicates a condition, hazard or unsafe practice that can result in minor personal injury or damage to the product.

WARNING

This product shall only be installed, repaired or serviced by an authorised electrician. All applicable local, regional and national regulations for electrical installations must be respected.

NOTE

PIN code: The PIN code is required for installation and located on the front of the Chargeberry.

PIN and Serial Number: The PIN and Serial Number sticker is removed by the installer and placed in a safe place, for example in the fuse cabinet. The Bluetooth connection to the charger uses the serial number as a name.

Manufacturing Date and Serial Number: The Chargeberry's month and year of manufacture and serial number are on the sticker on the Type-2 socket underneath the charger cover. The production date is displayed in MM/YY format, directly above the serial number, unique to each Chargeberry unit.

The manufacturing date can be found in DD/MM/YY format in the user app. Go to Charger settings, then About, then Manufactured.

Product overview

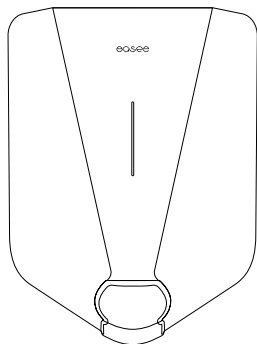

Front cover

Protects the electronics from external influences.

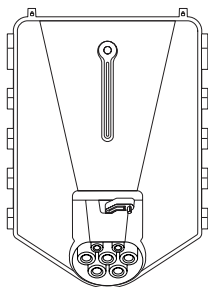

Chargeberry

(1.4 - 22 kW)

Contains the electronics for charging the vehicle.

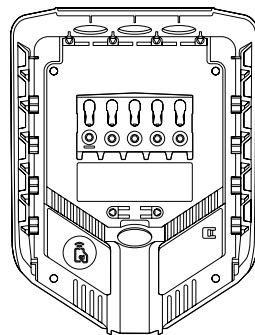

Backplate

(1.4 - 22 kW)

For attaching and connecting to the charging infrastructure.

Installation kit



Strain relief
x2



Blind grommets¹
x3



Sealing plug
x2



Strain relief
& front cover
screws (T25)
x 5



Wall screws
(T25)
x 4



Front cover
tool
x 1

¹ If blind grommets are not pre-installed in the backplate, you will find them in the installation kit.

Technical specifications

General

Dimensions	256 x 193 x 106 mm (H x W x D)
Wall mounting	c/c 160 x 125 mm (H x W)
Operating temperature	-30 °C to +40 °C
Weight	1.5 kg

Sensors and indicators

Light strip with LEDs showing the status of the charger

Touch button

Temperature sensors in all main contacts

Charging

Charging power	1.4–22 kW 6 A 1 phase – 32 A 3 phase (automatically adjusted in relation to available capacity) Up to 7.36 kW at 32 A 1 phase Up to 22 kW at 32 A 3 phase
Connection point	Type 2 socket (IEC 62196-2)
Number of phases	1 or 3 (fully dynamic)
Voltage	3x 230/400V AC (±10%)
Mains frequency	50 Hz
Load Control	One master unit can manage load balancing for up to 2 other Chargeberry units (3 total, including itself) without additional hardware. Dynamic load balancing capabilities are possible with the addition of the Easee Equalizer.
Built-in energy meter (±2 %)	

Connectivity

Built-in LTE Cat M1

WiFi 2.4 GHz b/g/n connection

Easee Link RF™

Bluetooth BLE 4.2

Control charging via Easee App

RFID/NFC reader

OCPP 1.6 via our API

Maximum Transmitted Power

WLAN (802.11b/g/n) 12.25 dBm, 16.8 mW, 2401-2483 MHz

SRD (non-specific) 13.5 dBm, 22.5 mW, 868.0-868.6 MHz

LTE FDD bands 1, 3, 8, 20 & 28

LTE band 1 21 dBm at 1920-1980 MHz, 2110-2170 MHz

LTE band 3 21 dBm at 1710-1785 MHz, 1805-1880 MHz

LTE band 8 21 dBm at 880-915 MHz, 925-960 MHz

LTE band 20 21 dBm at 832-862 MHz, 791-820 MHz

LTE band 28 21 dBm at 703-748 MHz, 758-803 MHz

Bluetooth 3.4 dBm, 2.2 mW, 2401-2481 MHz

RFID reader 3.3 dBuA/m (3m) at 13.56 MHz

Type-2 Outlet/Connection Point Protection

Integrated overload protection according to EN IEC 61851-1:2019, 13.1.

Integrated RCD type A 30 mA AC according to EN 60947-2, and 6 mA residual direct current detecting device (RDC-DD) complying with IEC 62955, 9.9.

Rated conditional short-circuit current (I_{cc}) 500 A
(does not provide overcurrent protection according to EN 60947-2)

Ingress protection rating (IP) IP54

Impact resistance IK10

Insulation class I²

Pollution degree 4 (installation environment)

EMC Classification Class A & Class B

Overvoltage category III

²Protection against electric shock in compliance with IEC 60364-4-41, 410.3.3: The Type-2 outlet is protected by "automatic disconnection of supply" (411). The backplate, Chargeberry, and front cover are constructed with "double or reinforced insulation" (412).

Backplate

Installation network	TN, IT or TT (detected automatically)
Installation circuit breaker	Maximum 40 A (Instantaneous trip, maximum 75 000 A ² s) ³
Wire material	Copper; solid, flexible, stranded
Wire cross-section	2.5 to 16 mm ² (single conductors) / 2.5 to 10 mm ² (parallel conductors) PE cross-section must be equal to or larger than the phase wire cross-section Cable dimensions must adhere either to IEC 60364-5-52 or local regulations
Cable diameter	8-22 mm
Terminal torque	5 Nm
Cable strip length	12 mm
Ingress protection rating (IP)	IP2X (without cover), IP34 (Easee Ready cover)

Protection against electric shock in compliance with IEC 60364-4-41, 410.3.3: The backplate is constructed with "double or reinforced insulation" (412).

³ Complying with IEC 60947-2, IEC 60947-6-2 or IEC 61009-1 or with the relevant parts of the IEC 60898 series or the IEC 60269 series.

Planning the installation

Prior to the installation, it is recommended that you consider future charging needs, so that you can easily expand accordingly in the future.

If several Charging Robots are connected to the same circuit, the total current is dynamically distributed between them. The connected Charging Robots communicate wirelessly between each other, ensuring the circuit is not overloaded. The maximum charging current is set during configuration.

For an optimal result

- We always recommend a 3-phase installation if possible, to make it future-proof.
- If possible, use the largest approved cable cross-section (see [Technical specifications](#)).
- Consider the installation of Easee Ready backplates if the acquisition of further Charging Robots is planned for the future.
- To avoid overloading the building's main fuse, the Easee Equalizer can be used for dynamic load balancing. The maximum current value can also be set as required during configuration.

Special notes

- Several backplates can be connected in parallel.
- Parallel conductors require twin ferrules when wired.
- The maximum supported charging current for the installation is only configurable by the installer. It cannot be altered by the user.
- If the charging infrastructure includes more than one Charging Robot, the backplate that is configured first becomes the master of its circuit.
- If more than 2 units are installed, the master unit should be located in the middle of the installation (if possible) for an optimal Easee Link communication.

- **Site Key:** During installation, a Site Key must be used to assign the Charging Robots to the correct location in the Easee Cloud. A Site Key will automatically be generated when creating a new charging site using the Easee Installer App or it can be obtained by creating a new charging site at portal.easee.com.

Your house, power grid and EV

The Charging Robot automatically adapts to the power grid, the electric car and the capacity of the electrical installation. In the table you can see what charging effect you can expect from your installation and situation. The table is only meant as a guide.

CAUTION

The type of installation as well as cable cross-sections must be determined by a qualified electrician in accordance with valid local, regional and national regulations for electrical systems.

Load	Charging power	
Ampere (A)	1 phase (kW)	3 phase (kW) ⁴
6	1.4	4.1
8	1.8	5.5
10	2.3	6.9
13	3.0	9
16	3.7	11
20	4.6	13.8
25	5.8	17.3
32	7.4	22

Padlock

It's possible to lock the electronics with a padlock. This will create an extra layer of security (padlock is not included).

Max total lock height	56 mm
Shackle height (outer dimensions)	19 - 20 mm
Shackle thickness	3.2 - 4 mm

⁴ Example for 400 V TN; deviating values for other grid types.

Residual Current Device (RCD)

- A Residual Current Device is integrated in the Charging Robot.
- The RCD will break the current in case a residual current exceeding 6 mA DC or 30 mA AC is detected.
- The RCD is automatically tested between each charging session or at least every 24 h.
- For manual initialization of the RCD-test, please refer to the Installer App.
- The integrated RCD has no influence on the function of external protective devices.

An external RCD is required when at least one of the below conditions are identified:

- The installation, including cable, junction boxes etc., includes components with only basic insulation (Class I).
- Any other electrical equipment apart from Easee Charge Up, including lamps and socket outlets, is connected to the circuit.
- Any other conditions identified by the authorized installer requiring an external RCD.

The internal RCD is considered to provide the required RCD protection for both AC and DC leakage faults for the charger and load when all the below conditions are fulfilled:

- The installation, including cable, junction boxes etc, is performed entirely with components providing double or reinforced insulation (Class II).
- No other electrical equipment apart from Easee Charge Up, including lamps and socket outlets, is connected to the circuit.
- No other conditions identified by the authorized installer requiring an external RCD.

For more information about the RCD, please go to [RCD Functional Description](#).

Installation instructions

⚠ WARNING

Turn off the power before you begin the installation. Use extreme caution and follow instructions carefully.

1 Charging Robot Opening

1. Bend down the lower part of the rubber cover and insert the two ends of the supplied tool into the two openings at the bottom of the front cover.
2. Pull the tool until the front cover comes loose and remove the cover.
3. Grasp the Type 2 socket and push upwards with good force until the Chargeberry disconnects.

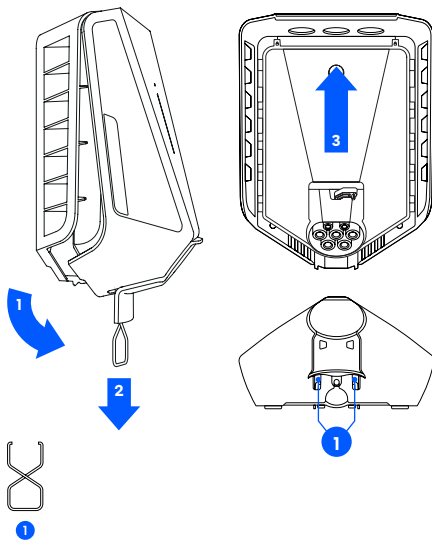

2 Backplate Mounting

1. Fix the backplate to a solid, non-perforated wall or structure with sufficient load-bearing capacity using the 4 wall screws provided in the mounting kit. Use suitable wall plugs for mounting and observe the local regulations for recommended installation height.

⚠ CAUTIONS

- The installation wall must cover the entire back of the product. If this is not possible to achieve, it is possible to use the Easee Mount.
- The area should not be exposed to direct rain, direct sunlight or explosive gases. A physical barrier is recommended to protect the charger.
- Install at a height of 130-140cm, with an angle no more than +/- 3 degrees from vertical. Suggested installation height for accessibility: 80-95 cm.

NOTE

If you are going to install multiple backplates, now would be a good time to mount them as well.

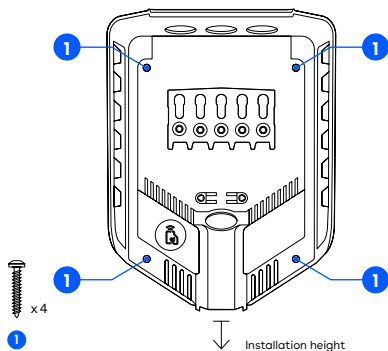

3 Backplate Preparing

1. Shorten the sealing plug to fit the cable. The hole should be slightly smaller to ensure a good seal.
2. Insert the cable through one of the 4 cable entries and secure it to the backplate with the strain relief provided. There must be at least 5 mm of cable extending beyond the strain relief.
3. Close all cable entries that are not in use with the blind sealing plugs supplied.

⚠ CAUTION

The wires must not cross over the screw terminals or the Chargeberry slots. This will prevent the Chargeberry from seating in the slots.

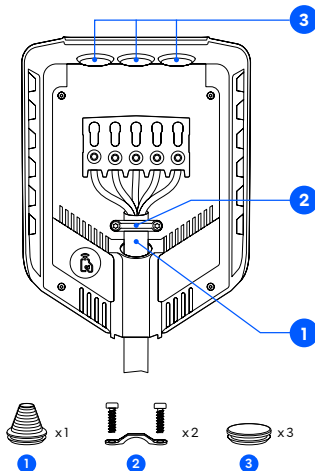

4 Backplate Wiring

1. Strip each wire, exposing 12 mm of copper on each. If the cable has flexible conductors, then you must use ferrules on stranded wires to make the connection. Use correct tools to press them.
2. Tighten the screw terminal with a torque of 5 Nm.

NOTES

- Each screw terminal serves as a coupling point for adjacent backplates. All backplates must be connected with the same phase sequence.
- It's recommended to follow the existing colour codes used in the installation. Depending on national standards, the colours of the cables can vary from the illustrations. The illustrations in this manual follow the IEC 60445 standard.
- Before turning on the power, make sure the wires are properly connected and tightened to the specified torque. Release cable tension by pulling on each wire and visually inspecting each terminal.
- The PE must have an equal or larger cross-section than the phase wire.

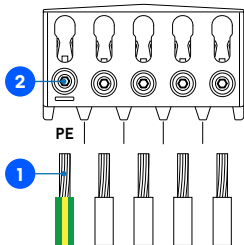

TN/TT 3-phase

(3x 230/400 V)

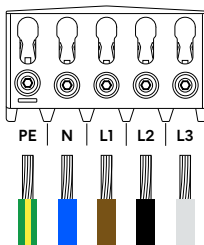

IT/TT 3-phase

(3x 230 V)

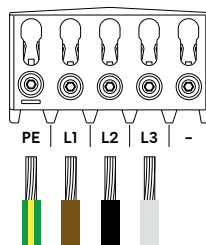

TN 1-phase

(230 V)

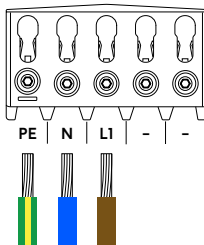

IT/TT 1-phase

(230 V)

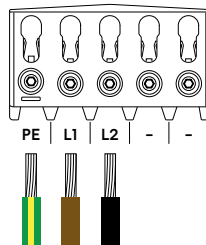

5 Backplate Configuring

1. Scan the QR code to download the Easee Installer App and create a free account.

NOTE

Your phone must support Bluetooth or NFC.

2. Select one of the two site setups in the Installer App:

Create new site: If this is a completely new charging site, select "Create new site". Enter the installation details, follow the on-screen instructions and return to this guide afterwards.

Update existing site: If this site already has one or more Charging Robots installed or if the site has been created by an operator, select "Update existing site" and search for the site address. On "Site overview", select the circuit that you want the backplate to be part of and select "Add another backplate". Follow the on-screen instructions and return to this guide afterwards.



easee.com/installer-app

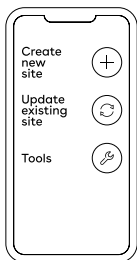

NOTE

If the charging circuits include more than one Charging Robot, the backplate that is configured first becomes the master unit of the charging infrastructure. To achieve the best communication flow, the centre backplate should be configured first.

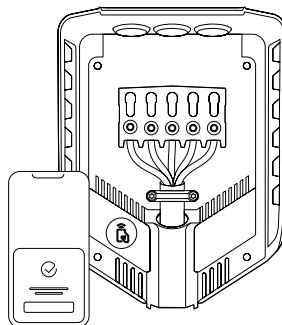

6 Chargeberry Attaching

⚠ WARNING

Insulation testing should be performed before a Chargeberry is installed in the backplate. Testing the circuit insulation with the Chargeberry installed in the backplate may damage the electronics or impact the reading negatively.

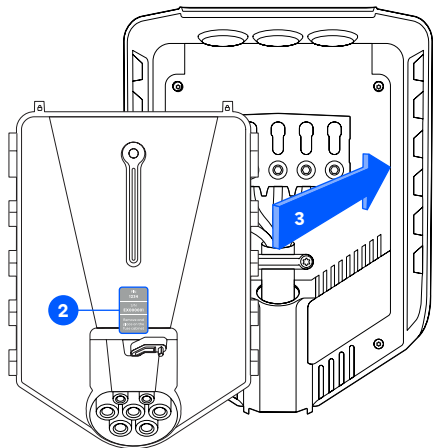

1. Turn on the power. The terminals of the backplates are now electrically live.
2. Remove the PIN code sticker and attach it to the inside of the fuse cabinet, or another safe location for storage.
3. Position the Chargeberry to fit into the slots on the backplate located in the center of the installation.
4. When the Chargeberry is in the track, press it forcefully down until you hear a "CLICK".

NOTE

You do not need to touch the terminals of either the Chargeberry or the backplate when installing or removing the Chargeberry.

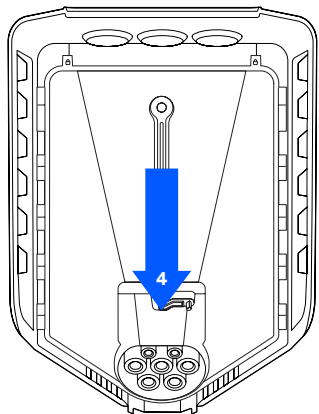

"CLICK!"

7 Front cover Closing

Before closing the front cover, it is possible to lock the Chargeberry with a padlock (see [Planning the installation](#)).

1. Hang the front cover at the top of the backplate and let it fall into place.
2. Press the bottom of the front cover until you hear a click.
3. Bend the lower part of the rubber cover down.
4. Screw in the locking screw at the bottom of the charger to secure the front cover.

NOTE! The locking screw is necessary to secure the cover and protect the charger from exposure.

5. Close the rubber cover. If the cable is inserted from the bottom, you can cut a corresponding hole in the rubber cover to ensure a neat installation.

The charger is now ready for testing according to local regulations. Once complete, transfer ownership to the owner via the Installer App.

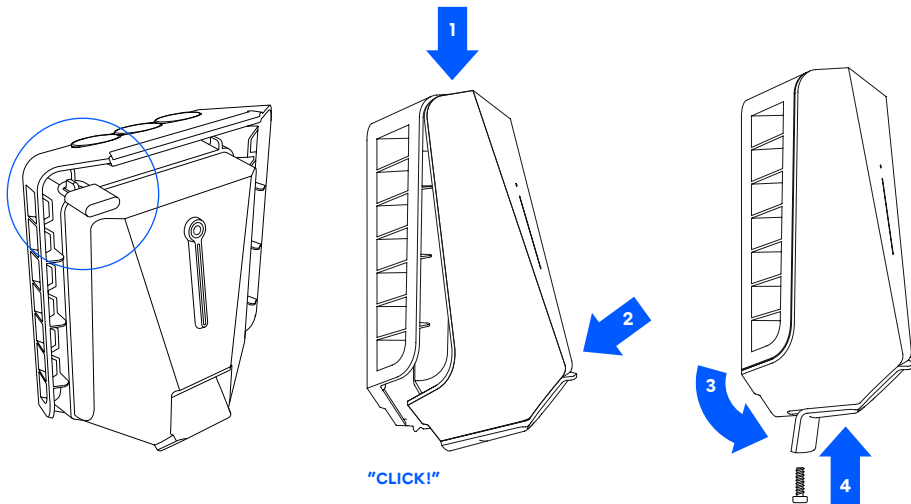

Features

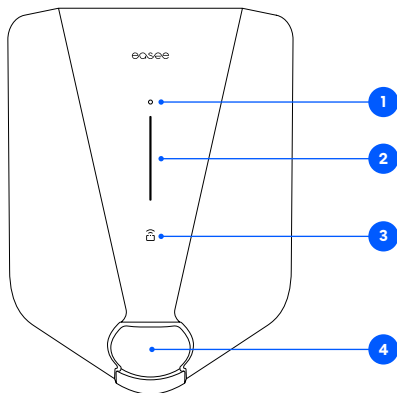

1. **Touch button:** The touch button is used to activate Bluetooth. Bluetooth connection in the app allows for local operation of the charger when no internet is available. Read more about the local interface at: easee.com/support/bt
2. **Light strip:** The light strip communicates the status of the Charging Robot at all times. (See [Charging Robot interface](#)).
3. **RFID area:** The integrated RFID reader enables access control of the Charging Robot and identification of different users. You can use it to unlock the charger with an Easee Key. Check our knowledge base at support.easee.com for more details on how to add and manage your Easee Keys.
4. **Type 2 socket:** The Type 2 socket is completely universal and allows you to charge any type of electric vehicle using the appropriate charging cable. Furthermore, it is possible to permanently lock the charging cable, so you do not have to worry about it being stolen.

NOTE: Adaptors should not be used on the charger or the charging cable. The charging cable must have appropriate sockets on each end.

Charging Robot interface

Light description	Status
White - constant light, only at the bottom 2 LEDs - master unit / 1 LED - secondary units	Standby
White - constant light	Car connected
White - pulsating light	Charging in progress
Blue - constant light	Smart charging enabled (car connected)
Blue - pulsating light	Smart charging in progress
At startup, the LEDs turn on one by one. When the charger is updating, one or more LEDs will flash green while this is in progress.	Updating software (updating can take up to 30 minutes) NOTICE! The car must be disconnected before a software update can be completed.
White - flashing light	Waiting for authentication by an RFID tag. Hold the RFID tag against the RFID area of the Charging Robot in order to authenticate and initiate the charging.
White - fast flashing light	RFID-tag received (awaiting key verification)
Red - flashing light, with warning sounds	⚠ WARNING Critical error! Turn off the power and remove the charging cable from the Charging Robot. The power can then be turned back on if necessary. The flashing red light will continue, but the warning sound will stop when the charging cable is disconnected. The charger is blocked from further use, cannot be reset and has to be replaced. Contact customer support.
Red - flashing light	⚠ WARNING Critical error! The charger is blocked from further use, cannot be reset and has to be replaced. Contact customer support.
Red - constant light	General error. Unplug the charging cable and replug it to the Charging Robot. If the red light persists, check the Easee App or our knowledge base ⁵ for further information.
Red - constant light, with warning sounds	Wires are connected incorrectly. Consult an authorised electrician.

⁵ Easee public knowledge base can be found at support.easee.com.

Light description	Status
Red - pulsating light	The Charging Robot has measured an abnormal temperature and has entered in safe mode. Please go to our knowledge base ² for further information.
White - flashing light, only at the bottom	The Charging Robot is searching for its master unit. Please check the status of the master unit. For further information, please check our knowledge base ⁵ .
Yellow - flashing light, only at the bottom	The Charging Robot is waiting to be configured. Consult an authorised electrician.

⁵Easee public knowledge base can be found at support.easee.com

The information in this document is for information purposes only, is provided as is, and may be subject to change without notice. Easee ASA including its subsidiaries does not accept any liability for the correctness or completeness of the information and illustrations, and is not liable or responsible for your considerations, assessments, decisions or absence of such, or other use of the information in this document.

No part of this publication may be re-published, reproduced, transmitted or re-used in any other form, by any means or in any form, for your own or any third-party's use, unless otherwise agreed with Easee or its subsidiaries in writing. Any permitted use shall always be done in accordance with good practice and ensure that no harm may be caused to Easee or by misleading the consumer.

Easee and Easee products, product names, trademarks and slogans, whether registered or not, are Easee's intellectual property and may not be used without Easee's prior written permission. All other products and services mentioned may be trademarks or service marks of their respective owners.

September 2024 – Version 1.01
© 2024 by Easee ASA. All rights reserved.



Easee ASA
Vassbotnen 23
4033 Stavanger, Norway
www.easee.com