



SPLIT TYPE AIR CONDITIONER

⚠ CAUTION! WARNING: Do not use this device before reading these instructions.

USER'S MANUAL

		Model No.		
048-MS-T1159K	048-MS-T239K	048-MS-T11512K	048-MS-T2312K	048-MS-T11518K
		048-MS-T2324K		048-MS-T2318K

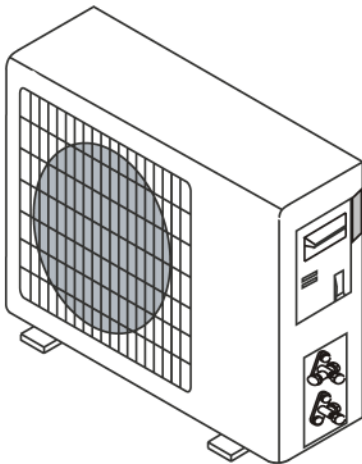

NOTICE:

If your package is missing parts or you are having issues with assembly, please call Belleze Furniture directly at (909)-595-5901. The Belleze Furniture customer service team will address any questions or concerns you may have. Have this manual open and ready for reference.

CUSTOMER SERVICE:

909-595-5901
9:00AM - 6:00PM PST (Monday - Friday)

manufacturer@dellaproductsusa.com
www.dellaproductsusa.com

Table of Contents

Warnings & Precautions -----	03
Technical Specification -----	05
Parts and Features -----	07
Controller Instruction --- -----	09
Installation Instruction -----	19
Installation Instruction (Indoor unit) -----	20
Installation Instruction (Outdoor unit) -----	23
Operation Test -----	25
Installation Information -----	26
Care and Maintenance -----	27
Troubleshooting -----	28

SAFETY RULES AND RECOMMENDATIONS FOR THE INSTALLER

- Read this guide completely before installing and using the unit.
- For electrical work, contact the dealer, seller, a qualified electrician, or an Authorized Service Center. Do not disassemble or repair the product by yourself.
- During the installation of the unit, please make sure children are children have no access to or are near the area.
- Make sure the base of the unit is firmly fixed and stable.
- Check that air cannot enter the refrigerant system and check for leaks when moving the unit.
- Carry out a test cycle after installing the unit and be sure to keep record of the operating data.
- The fuse parameters for this unit are T5A/250V.
- Use the correct fuse or breaker for this unit.
- The user must protect the unit with a fuse of suitable capacity for the maximum input.
- Do not use a extension cord. Always use this appliance on a dedicated circuit and breaker.
- Always ground the product as per the wiring diagram. Do not connect the ground wire to gas or water pipes lightening rod or telephone ground wire.
- Do not use a defective or underrated circuit breaker. Use the correctly rated breaker and fuse.
- Check that the socket is suitable for the plug or it can damage the socket or plug.
- Do not use the product in a tightly closed space for a long time. Perform -ventilation regularly.
- Do not install the appliance at a distance less than 20 inches from a flammable substance.
- Only use the unit as instructed in this booklet. These instructions are not intended to cover every possible condition and situation.
- Installation work must be performed in accordance with the National Electric Code by qualified and authorized personnel only.
- Comply with all national electrical codes and local electrical codes. -Cut off the power supply of air conditioner before checking and maintenance.
- All electric work must be performed by a licensed technician according to local regulations and the instructions given in this manual.
- This appliance can be used by children aged 8 and above under supervision of an adult that have given them instruction concerning the use of the unit in a safe way and are aware of the hazards involved. Children shall not play with the appliance. Cleaning and maintenance shall not be made by children without supervision.
- Dispose the unit or any parts at a special waste collection center as it can be recycled at the end of its life.

SAFETY RULES AND PROHIBITIONS

- **DO NOT** operate the unit with a damaged plug or loose wall outlet. If the power cord is damaged, it must be replaced by the manufacturer or an authorized service agent.
- **DO NOT** bend, tug, or compress the power cord.
- **DO NOT** use extensions or gang modules.
- **DO NOT** cover the air intake and exhaust when in use.
- **DO NOT** touch the product if you are barefoot, or any part of your body is wet or damp.
- In no way should you alter the unit.
- **DO NOT** install the unit in an area where there is gas, oil, or sulphur or near any heat sources.
- This unit is not intended for use by persons (or children) with reduced physical, sensory or mental capabilities, or lack of experience or knowledge, unless they have been given supervision or instruction concerning use of the appliance by a person responsible for their safety.
- **DO NOT** climb or place anything on the unit.
- **DO NOT** leave windows or doors open while operating the unit.
- **DO NOT** direct the airflow onto plants or animals.
- **DO NOT** let the unit come in contact with water.
- **DO NOT** insert any objects into the unit.
- This appliance is not intended for use by children. Children should be supervised and should not play on or around the appliance.

TECHNICAL SPECIFICATION

048-MS-T1159K
SEER rating: 15.5
Capacity: 9000 BTU/h
Voltage: 115V
Frequency: 60Hz
NW (indoor unit): 15.65lb
NW (outdoor unit): 48.50lb
GW (indoor unit): 17.86lb
GW (outdoor unit): 57.32lb
Dimension (indoor unit): 28.27" x 9.45" x 7.09"
Dimension (outdoor unit): 27.56" x 10.08" x 21.65"

048-MS-T11512K
SEER rating: 15.5
Capacity: 12000 BTU/h
Voltage: 115V
Frequency: 60Hz
NW (indoor unit): 19.84lb
NW (outdoor unit): 61.73lb
GW (indoor unit): 22.05lb
GW (outdoor unit): 71.21lb
Dimension (indoor unit): 31.31" x 9.45" x 7.09"
Dimension (outdoor unit): 27.56" x 10.08" x 21.65"

048-MS-T11518K
SEER rating: 15.0
Capacity: 18000 BTU/h
Voltage: 230V
Frequency: 60Hz
NW (indoor unit): 24.25lb
NW (outdoor unit): 81.57lb
GW (indoor unit): 28.66lb
GW (outdoor unit): 88.19lb
Dimension (indoor unit): 35.43" x 10.71" x 7.64"
Dimension (outdoor unit): 30.71" x 11.42" x 23.82"

048-MS-T239K
SEER rating: 25
Capacity: 9000 BTU/h
Voltage: 208-230V
Frequency: 60Hz
NW (indoor unit): 19.84lb
NW (outdoor unit): 70.55lb
GW (indoor unit): 24.25lb
GW (outdoor unit): 77.16lb
Dimension (indoor unit): 31.5" x 11.02" x 7.28"
Dimension (outdoor unit): 29.92" x 21.73" x 10.08"

048-MS-T2312K
SEER rating: 25
Capacity: 12000 BTU/h
Voltage: 230V
Frequency: 60Hz
NW (indoor unit): 22.05lb
NW (outdoor unit): 74.00lb
GW (indoor unit): 27.12lb
GW (outdoor unit): 80.60lb
Dimension (indoor unit): 35.35" x 11.02" x 7.95"
Dimension (outdoor unit): 30.71" x 23.82" x 11.42"

048-MS-T2318K
SEER rating: 21.5
Capacity: 18000 BTU/h
Voltage: 230V
Frequency: 60Hz
NW (indoor unit): 37.48lb
NW (outdoor unit): 97.00lb
GW (indoor unit): 48.50lb
GW (outdoor unit): 103.00lb
Dimension (indoor unit): 35.43" x 10.71" x 7.64"
Dimension (outdoor unit): 30.71" x 11.42" x 23.82"

TECHNICAL SPECIFICATION

048-MS-T2324K

SEER rating: 18

Capacity: 24000 BTU/h

Voltage: 230V

Frequency: 60Hz

NW (indoor unit): 37.48lb

NW (outdoor unit): 145.00lb

GW (indoor unit): 48.50lb

GW (outdoor unit): 154.00lb

Dimension (indoor unit): 46.69" x 13.39" x 10.24"

Dimension (outdoor unit): 35.43" x 31.69" x 14.17"

PARTS & FEATURES

Indoor Unit	
1.	Front panel
2.	Air filter
3.	Optional filter (if installed)
4	LED Display
5.	Signal Receiver
6.	Terminal Block Cover
7.	Ionizer generator(if installed)
8.	Vertical air deflector
9.	Emergency button
10	Indoor unit rating label (Stick position optional)
11.	Horizontal air deflector
12.	Remote controller

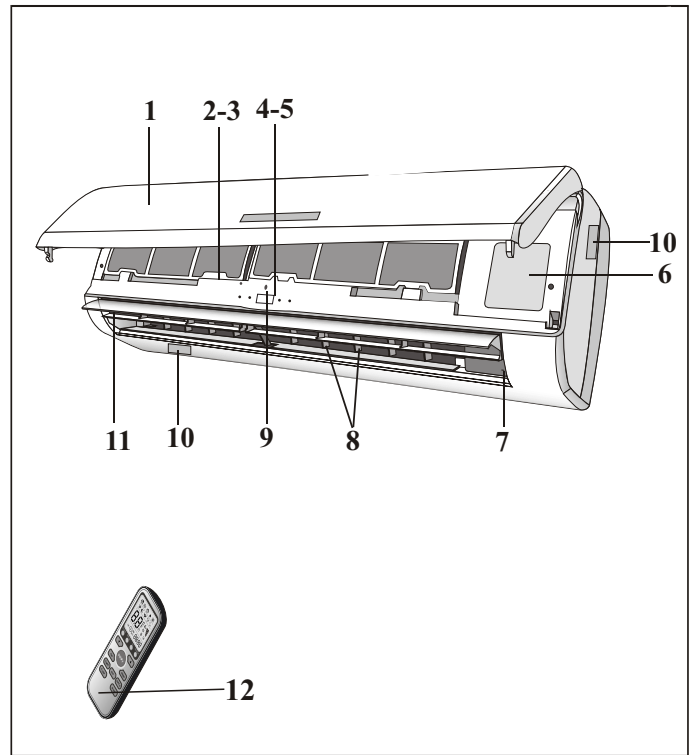

Outdoor Unit	
1.	Air Outlet Grille
2.	Outdoor unit rating label
3.	Terminal Block Cover
4	Gas Valve
5.	Liquid Valve

Note: the above figures are only intended to be a simple diagram of the appliance and may not correspond to the appearance of the units that have been purchased.

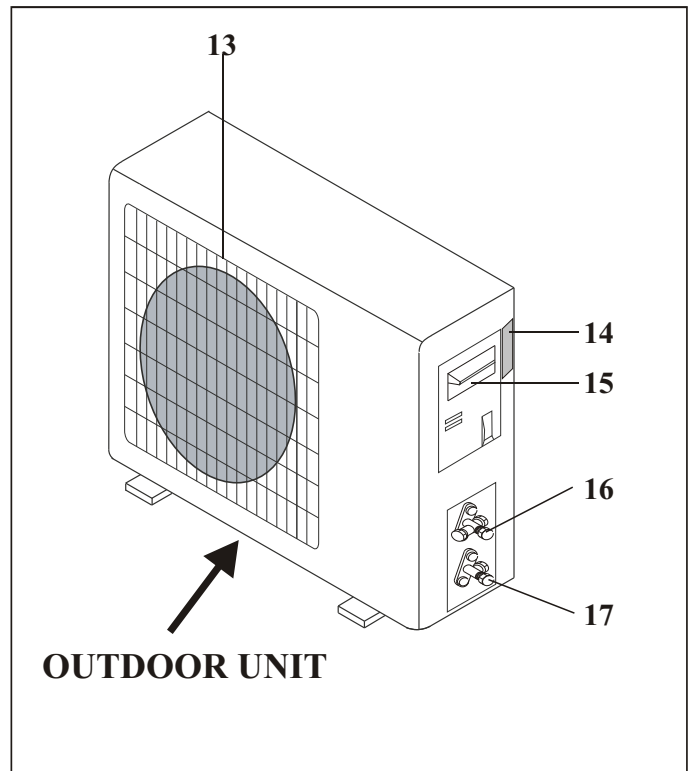

PARTS & FEATURES

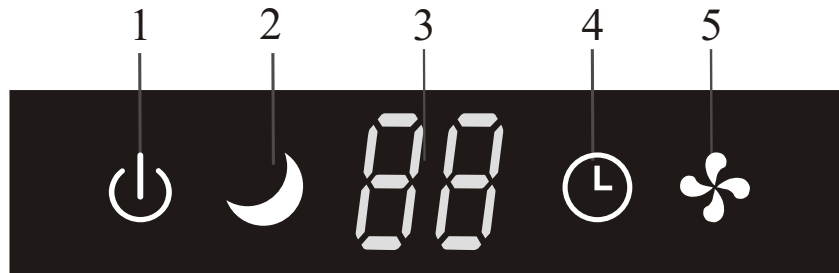

No.	Function		
1.	POWER	⏻	This symbol appears when the unit is on
2.	SLEEP	☾	SLEEP mode
3.	Temperature display (if present) /Error code	88	(1) Lights up during Timer operation when the air conditioner is operational (2)Displays the malfunction code when fault occurs.
4.	TIMER	⌚	Lights up during Timer operation.
5.	RUN	🌀	The symbol appears when the unit is turned on, and disappear when the unit is turned off.

AUTO-RESTART FUNCTION

The appliance is preset with auto-restart function by the manufacturer. In case of a sudden power failure, the module memorizes the setting conditions before the power failure. When the power restores, the unit restarts automatically with all the previous settings preserved by the memory function.

To deactivate the AUTO-RESTART function ,proceed as follows:

1. Switch the air conditioner off and plug it off.
2. Press the emergency button meanwhile plug it in.
3. Keep pressing the emergency button for more than 10 seconds until you hear four short beeps from the unit. The AUTO-RESTART function is deactivate.

To activate the AUTO - RESTART function , follow the same procedure until you hear three short beeps from the unit.

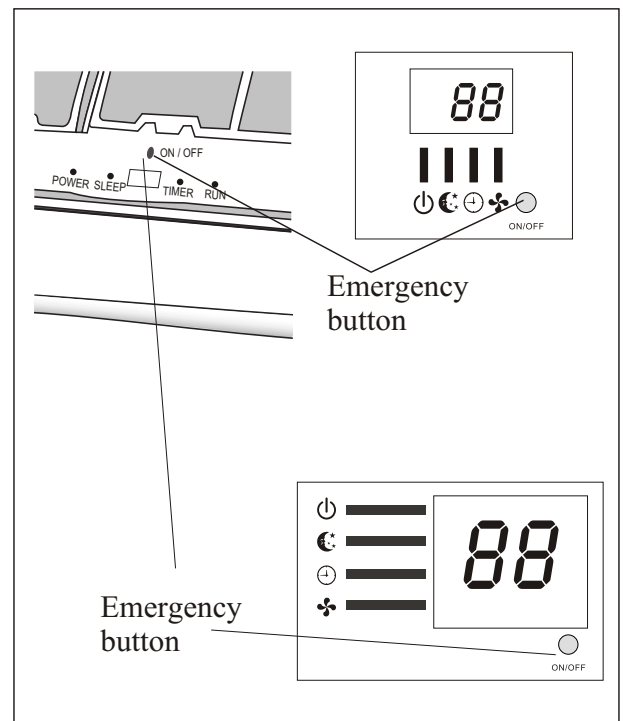



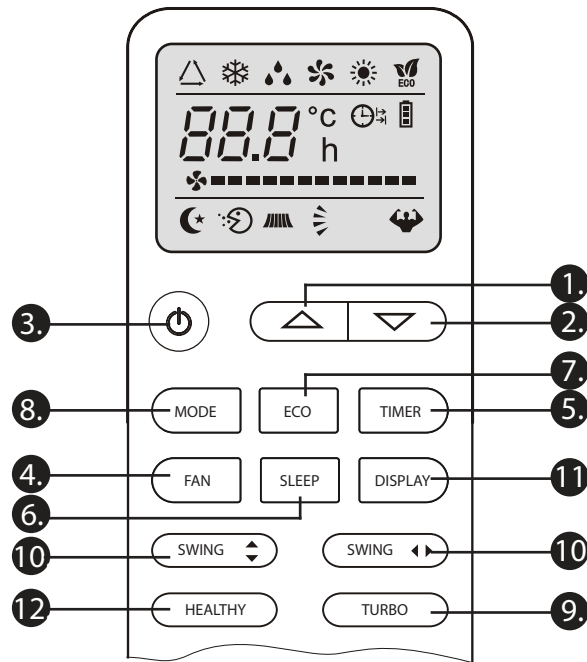





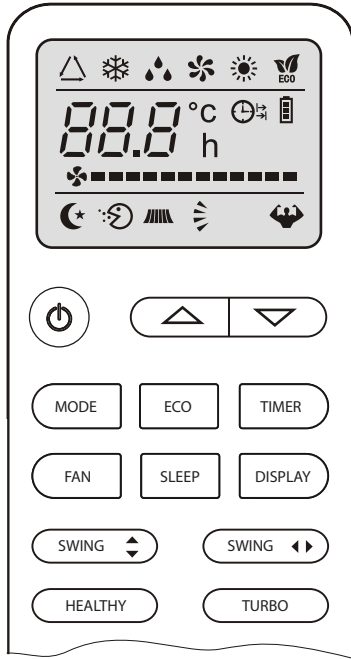





PARTS & FEATURES



NO.	FUNCTION	
1.	(TEMP UP)	Press it to increase temperature / time setting.
2.	(TEMP DOWN)	Press it to decrease temperature/ time setting.
3.	ON/OFF	Press it to start or stop operation.
4.	FAN	To select the fan speed of auto/low/mid/high
5.	TIMER	Press it to set auto-off timer.
6.	SLEEP	To activate the function "SLEEP"
7.	ECO	On cooling mode,press this button ,the temperature will increase 2 on the base of setting temperature. In heating mode, press this button, the temperature will decrease 2 on the base of setting temperature.
8.	MODE	To select the mode of operation
9.	SUPER or TURBO	Press this button to activate / deactivate the Super function which enables the unit to reach the preset temperature in the shortest time. In COOL mode, the unit will give the maximum cooling temperature with 16°C (60.8°F) ,high fan speed. In HEAT mode, the unit will give the maximum heating temperature with 31°C (87.8°F),high fan speed.
10.	SWING	To activate or deactivate of the movement of the air deflectors.
11.	DISPLAY	To switch on/off the LED display.
12.	HEALTHY	To switch - on /off HEALTHY function.It is a button which controls the ionizer or plasma genera for available model only.

PARTS & FEATURES



FUNCTION	
	FEEL mode indicator
	COOLING indicator
	DEHUMIDIFYING indicator
	FAN ONLY OPERATION indicator
	HEATING indicator
	TIMER OFF indicator
	TIMER ON indicator
	SLEEP indicator
	FLAP SWING indicator
	SUPER indicator
	HEALTHY indicator
	ECO indicator
	BATTERY indicator
	CLOCK indicator

REPLACE BATTERIES

Remove the battery cover plate from the rear of the remote controller, by sliding it in the direction of the arrow. Install the batteries according the direction (+and -)shown on the Remote Controller. Reinstall the battery cover by sliding it into place.

⚠ Use 2 LRO 3 AAA (1.5V) batteries . Do not use rechargeable batteries . Replace the old batteries with new ones of the same type when the display is no longer legible. Do not dispose batteries as unsorted municipal waste. Collection of such waste separately for special treatment is necessary.

⚠ Refer to picture 1:

I. When you open the battery cover, you can see a DIP switch on the cover back. (pic 1.)

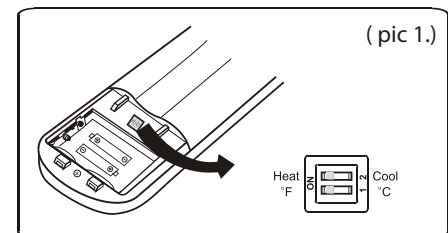
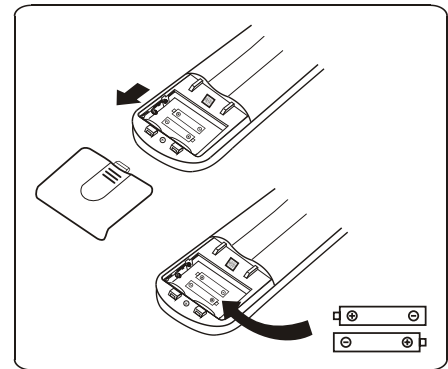

DIP switch on position	Function
° C	The remote controller is adjusted in degree Celsius
° F	The remote controller is adjusted in degree Fahrenheit.
Cool	The remote controller is adjusted in only cooling mode
Heat	The remote controller is adjusted in cooling and heating mode

II. NOTE:After adjusting the function, you need to take out the batteries and repeat the procedure described above.

Refer to picture 2:

Refer to picture 2:

When you insert the batteries for the first time in the remote controller or if you change them, you need to program the remote controller of only cooling or cooling and heating.

When you insert the batteries, the symbols ❄ (COOL) and ☀ (HEAT) start flashing. If you push whatever button when the symbol ❄ = (COOL) is displayed, the remote controller is adjusted in only cooling mode . If you push whatever button when the symbol ☀ (HEAT) is displayed , the remote controller is adjusted in Cooling and heating mode.

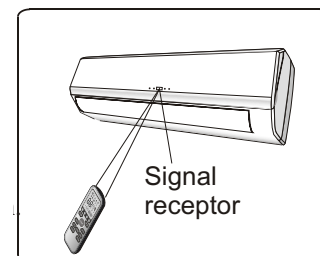
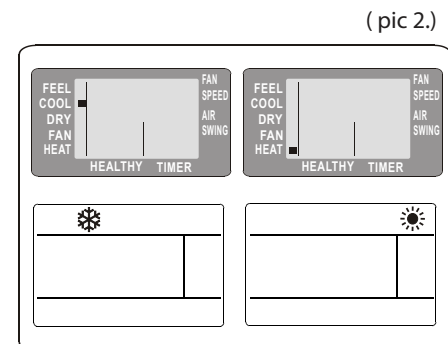

REPLACE BATTERIES

NOTE: if you adjust the remote controller in cooling mode, it will not be possible to activate the heating function in units with heating pump . you need to take out the batteries and repeat the procedure described above.

1. Direct the remote controller toward the Air conditioner.
2. Check that there are no objects between the remote control and the Signal receptor in the indoor unit.
3. Never leave the remote controller exposed to the rays of the sun.
4. Keep the remote controller at a distance of at least 1m from the television or other electrical appliances.

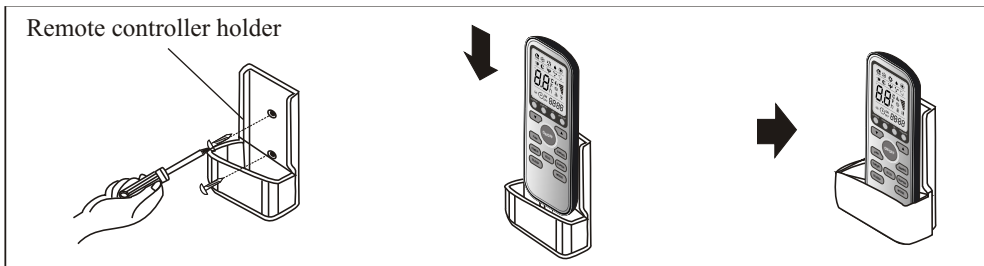

Recommendations for locating and using the remote controller holder- (if present) The remote controller be kept in a wall-mounted holder

OPERATION INSTRUCTIONS

The air sucked by the fan enters from the grill and passes through the filter, then it is cooled/dehumidified or heated through the heat exchanger.

The direction of the air outlet is motorized up and down by horizontal air deflector, and manually moved right and left by the vertical air deflectors. For some models, the vertical air deflectors could be controlled by motor as well.

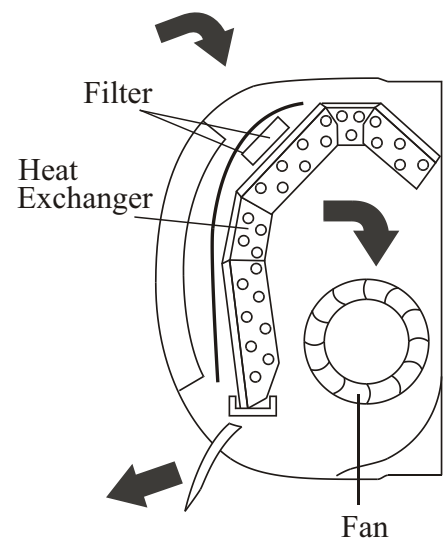

SWING- CONTROL OF THE AIR FLOW

The air outlet flow is uniformly distributed in the room.

It is possible to position the direction of the air in the optimal.

The key SWING or SWING \blacklozenge activates the horizontal air deflector , the air flow is directed alternatively from up to down .In order to guarantee an even diffusion of the air in the room.

The key SWING $\blacktriangleleft\blacktriangleright$ activates the vertical air deflectors , the air flow is directed alternatively from left to right. (Optional function, depends on the models)

In cooling mode , orient the vertical air deflectors in a horizontal direction;
In heating mode, orient the horizontal air deflector downward as the warm air tends to rise.

The vertical air deflectors are positioned manually and placed under the horizontal air deflector .They direct the air flow rightward or leftward.

- ⚠ This adjustment must be done while the appliance is switched off.
- ⚠ Do not position horizontal air deflector manually to prevent damaging the mechanism.
- ⚠ Do not touch or stick any objects in the air inlet or outlet vents, to prevent damaging the appliance or cause injury.

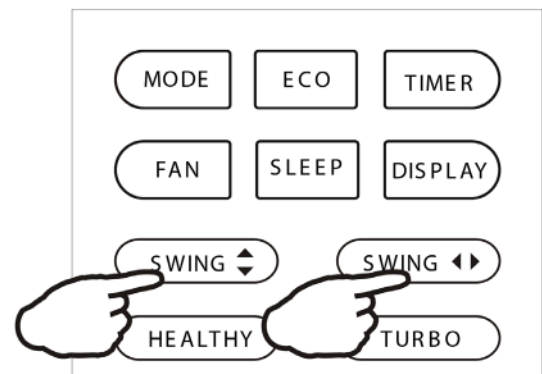
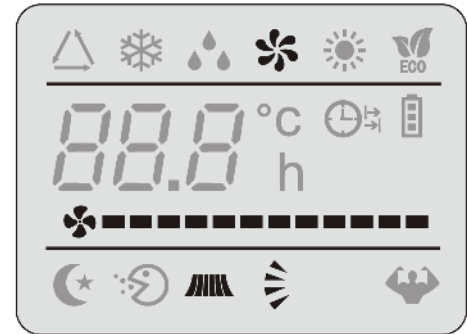

COOLING FUNCTION

The cooling function allows the air conditioner to cool and reduce humidity.

To activate cooling function, press MODE button until the symbol ❄️ appears on the display.

The cooling function is activated by setting the desire temperature lower than the room temperature.

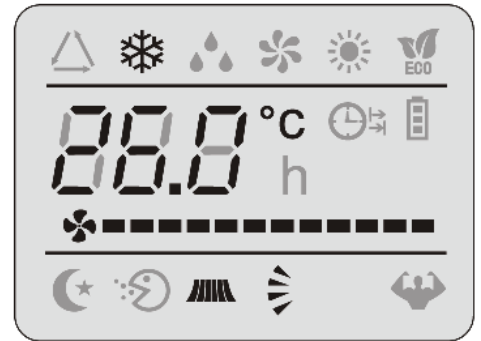

HEATING FUNCTION

The heating function allows the air conditioner to warm up the room.

To activate heating function, press MODE button until the symbol ☀️ appears on the display.

The heating function is activated by setting the desire temperature higher than the room temperature.

- ⚠️ Start up will delay for a few seconds to ensure immediate hot air output if the appliance is fitted with an electrical heater. (Only applicable to certain model)
- ⚠️ In heating operation, the appliance could automatically activate defrost cycle before proceed to heating function. This procedure usually last for 2 - 10 minutes. The appliance will resume to heating mode after defrosting.

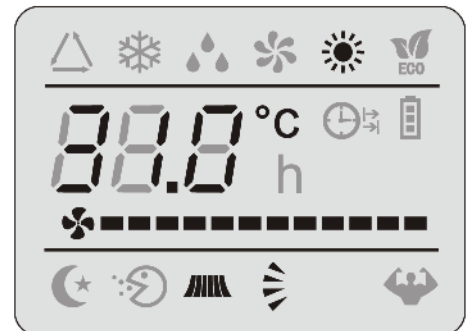

TIMER TURN ON

The time on function allows the air conditioner to be programmed with a automatic turn on time. When setting the program, the appliance should be power off.

Press TIMER button for the first time, set the desire temperature, select desired mode by pressing MODE, and select desired fan speed by pressing FAN;
Press TIMER again, set the rest time;
Press TIMER the third time, confirm the setting.

The rest time till the unit automatic turn on could be shown on the display

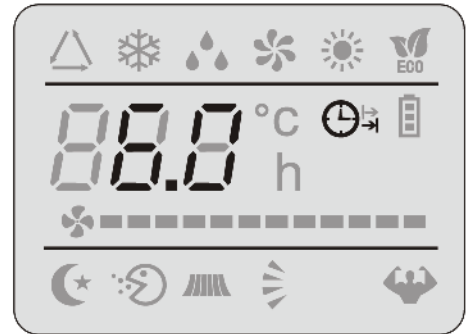

TIMER TURN OFF

The time on function allows the air conditioner to be programmed with a automatic turn off time.

Press TIMER button to set the rest time;
Press TIMER again to confirm.

⚠ To cancel the set function, press the TIMER button again.

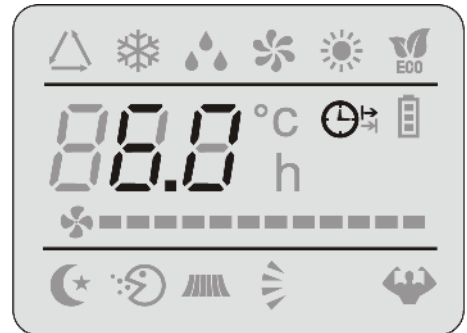

FAN MODE

Use the appliance as air circulator

To select FAN mode, press MODE button until  appears on the display.

Press FAN button to change fan speed in the following sequence: LOW / MEDIUM / HIGH / FEEL.

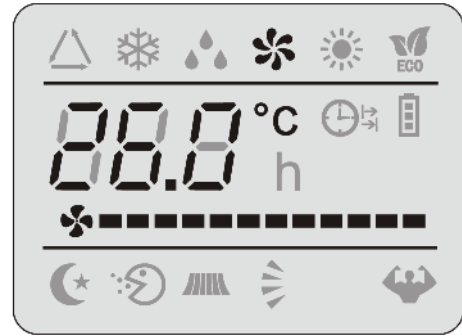

DRY MODE

The dry function dehumidify the air in the room.

To select DRY mode, press MODE button until  appears on the display. An automatic function of alternating cooling cycles and air fan will be activated

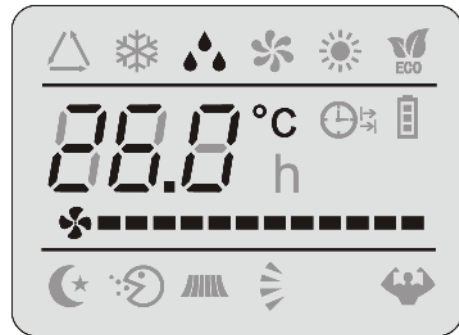

FEEL MODE

To select FEEL mode, press the MODE button until the symbol  appears on the display.

The unit will automatically select fan speed and temperature according to the room temperature in FEEL mode.

Ambient temp.	Operation mode	Auto temp.
<20°C (68°F)	Heating / Fan	23°C (73.4°F)
20°C-26°C (68°F-78.8°F)	Dry	18°C (64.4°F)
26°C (78.8°F)	Cool	23°C (73.4°F)

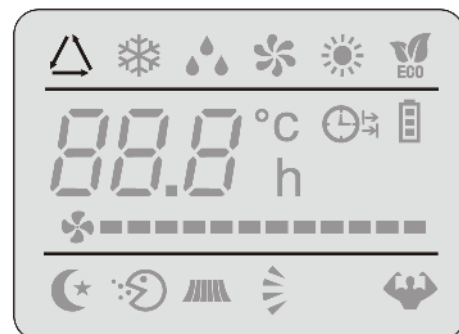

SLEEP MODE

To activate SLEEP mode, press the SLEEP button on the remote control until the symbol  appears on the display.

The appliance will automatically adjust the temperature in SLEEP mode. In cooling or dry mode, the set temperature will automatically raise by 1°C every 60 minutes, to achieve a total rise of 2°C during the first 2 hours of operation.

In heating mode, the set temperature is gradually decrease by 2°C during the first 2 hours of operation.

The air conditioner will automatically turn off after operating in sleep mode for 10 hours.

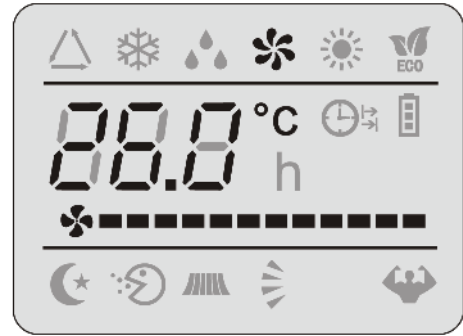

PROTECTION

The air conditioner is programmed with self-protection features. If the unit is used in abnormal condition as below, the protection might activate.

For T1 Climate condition models:

No.	MODE	Ambient Temp.
1	Heating	Outdoor > 24°C (75.2°F)
		Outdoor < -7°C (19.4°F)
		Room > 27°C (80.6°F)
2	Cooling	Outdoor > 43°C (109.4°F)
		Room < 21°C (69.8°F)
3	Dry	Room < 18°C (64.4°F)

For Tropical T3 Climate condition models:

No.	MODE	Ambient Temp.
1	Heating	Outdoor > 24°C (75.2°F)
		Outdoor < -7°C (19.4°F)
		Room > 27°C (80.6°F)
2	Cooling	Outdoor > 52°C (125.6°F)
		Room < 21°C (69.8°F)
3	Dry	Room < 18°C (64.4°F)

⚠ The unit does not operate immediately if it is turned on right after being turned off, or after changing operation mode. This is normal self-protection feature. You will need to wait for about 3 minutes.

⚠ The capacity and efficiency are tested under the unit operating in full load.*

*The highest indoor fan motor speed and maximum opening angle of the horizontal and vertical air deflector are used.

INSTALLATION INSTRUCTION

CHOOSING THE MOUNTING SITE

INDOOR UNIT

- The unit should be mounted at stable, non-vibratory location which can provide full support of the unit.
- No obstruction near the air inlet and outlet.
- Do not install the unit near source of heat, steam, or flammable gas.
- Install the unit near an electric socket or private circuit.
- Avoid install the unit in locations which will expose to direct sunlight.
- Make sure condensed water can be easily drained
- Make sure the location is easily accessible for regular maintenance
- Ensure clearance space around the unit

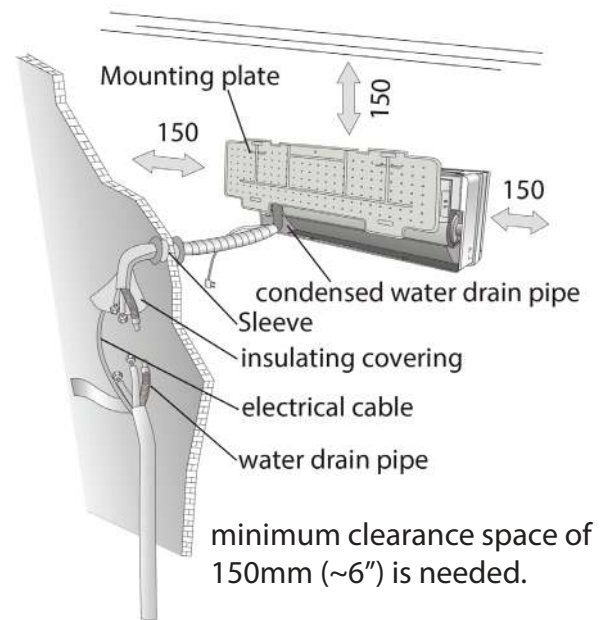

OUTDOOR UNIT

- The unit should be installed at a location which can support the unit.
- Do not install the unit near sources of heat, steam, or flammable gas.
- Do not install the unit in an area that is dusty and/or windy.
- Do not expose the unit in direct sunlight or rain. (Use protection if necessary)
- Ensure water drainage and air flow.

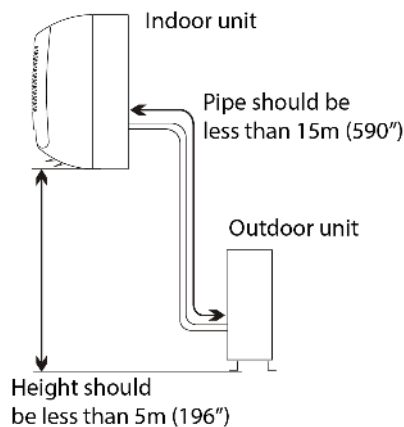
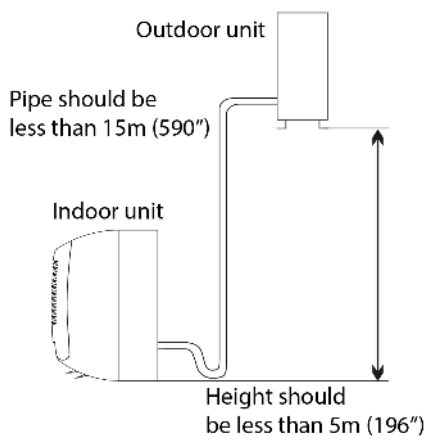
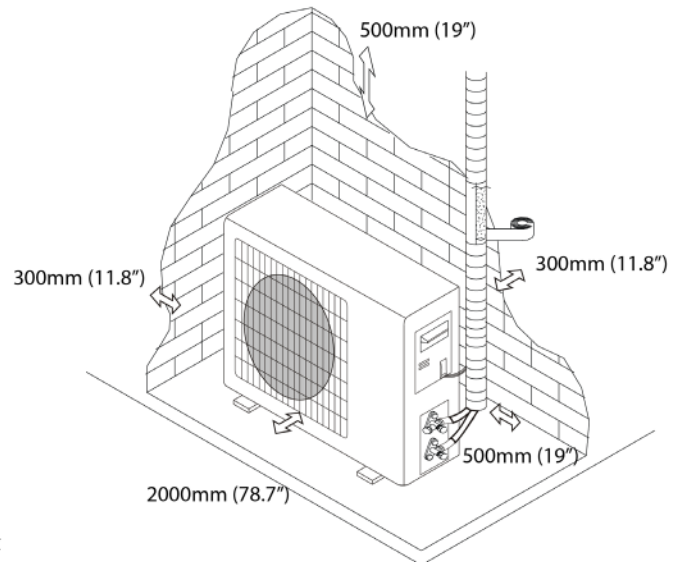

INSTALLATION INSTRUCTION (INDOOR UNIT)

BEFORE INSTALLING

- The indoor unit should be installed 250cm (98") or more above the floor.
- Do not install your air conditioner in a wet room such as a bathroom or laundry room etc.

MOUNTING PLATE INSTALLATION

- Install the mounting plate horizontally or slightly tilted down toward the side of the drain hose. If it is tilted above the drain hose side, condensed water may overflow.
1. Drill 32mm (1.25") deep holes in the wall.
 2. Insert plastic anchors into the holes;
 3. Fix the mounting plate on the wall and firmly secure it using the provided tapping screws.

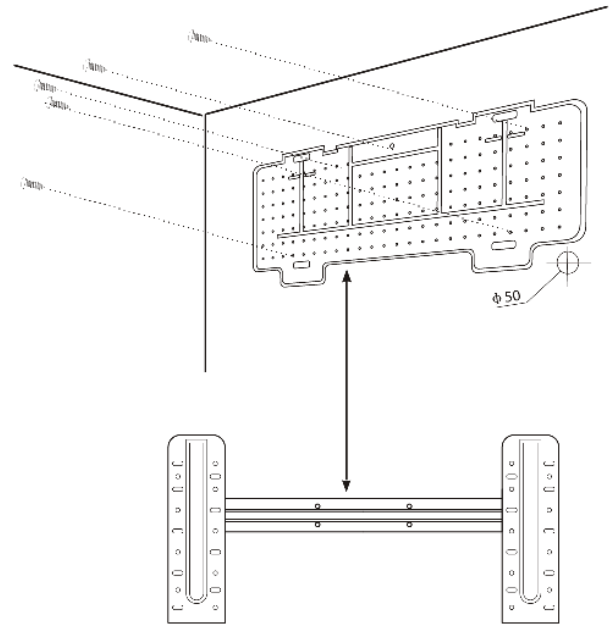

WALL PIPING INSTALLATION

1. Drill a piping hole (Φ65) in the wall at a slight downward tilt towards the outdoor side.
 2. Insert the piping hold sleeve through the hole.
- NOTE: Keep the drain pipe tilted downward through the hole to prevent condensed water leakage / overflow.

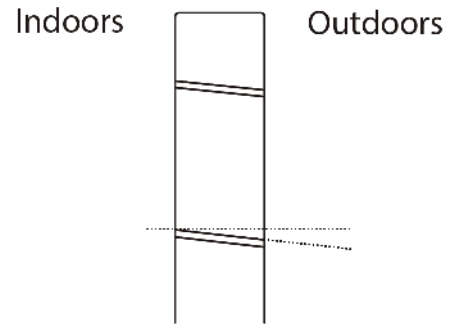

INDOOR UNIT ELECTRICAL CONNECTIONS

1. Open the front panel.
2. Take off the terminal block cover by removing the screw or breaking the hooks.
3. Connect the cable wires according to the circuit diagram which is located on the right part under the front panel.
4. Use wire size suitable to the electric power input and follow all national safety code requirements.

- ⚠ The cable connecting the indoor and outdoor units must be suitable for outdoor use.
- ⚠ The plus should remain accessible after the appliance has been installed.
- ⚠ Ensure an efficient earth connection.

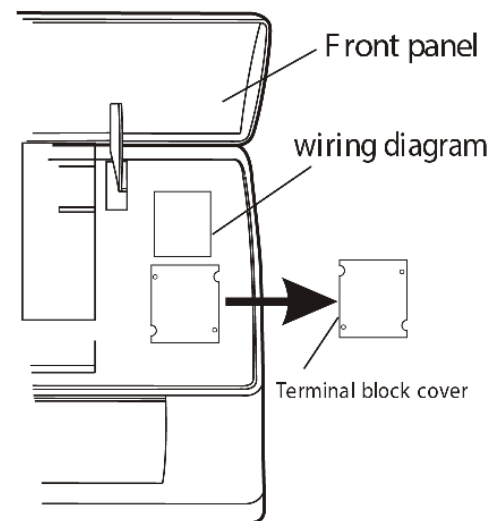

INSTALLATION INSTRUCTION (INDOOR UNIT)

REFRIGERANT PIPING CONNECTION

The piping can be run in 3 directions. If the piping is run in direction 1 or 3, cut a notch along the groove on the side of the indoor unit with a cutter and smoothen the edges with a file.

Run the piping in the direction of the hole in the wall and bind the copper pipes, the drain pipe, and the power cables together with the tape. Make sure to leave the drain pipe at the bottom, so that water can flow freely.

- Do not remove the cap from the pipe until connecting it to avoid moisture or dirt from entering.
- Do not over-bent or pulled the pipe. The copper pipe will harden. Avoid bending the same section more than three times.
- When extending the rolled pipe, straighten the pipe by unwinding it gently.

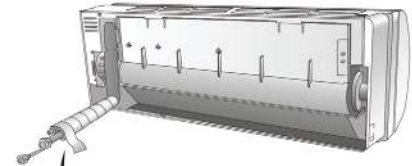
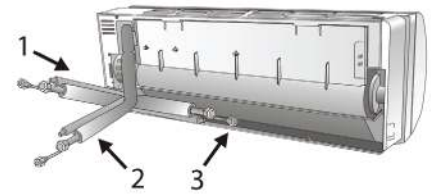

Shape the connection pipe

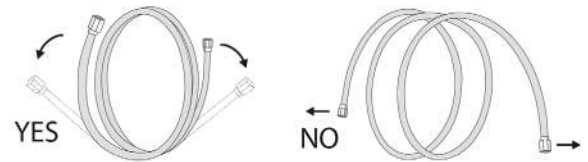

Extending the rolled pipe

INDOOR UNIT CONNECTION

1. Remove the indoor unit pipe cap and check it has no debris inside.
2. Insert the flare but and create a flange at the very end of the connection pipe.
3. Tighten the connections by using two wrenches working in opposite directions.

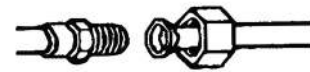

torque wrench

INSTALLATION INSTRUCTION (INDOOR UNIT)

CONDENSED WATER DRAINAGE

1. Place the drain hose below the piping.
2. The drain hose must slant downwards to the outdoor side.
3. Do not bend the drain hose or leave it protruding or twisted. Do not put the end of the hose into water.
4. If the piping is installed to the right, the pipe, power cable, and drain hose must be tied and secured onto the rear of the unit with a pipe connection.

⚠ Ensure the smooth flow of the condensed water drainage to prevent leakage or overflow.

FINISHING THE INDOOR UNIT INSTALLATION

1. Arrange the pipes, cables, drain-hose according to the image. Cover the pipe joints with insulating material and secure it with vinyl tape.
2. Run the bounded pipe through the hole on the wall and mount the indoor unit onto the upper part of the mounting plate securely.
3. Press and push the lower part of the indoor unit tightly against the mounting plate.

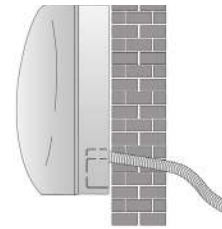

YES

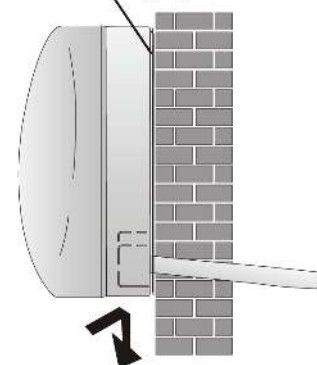
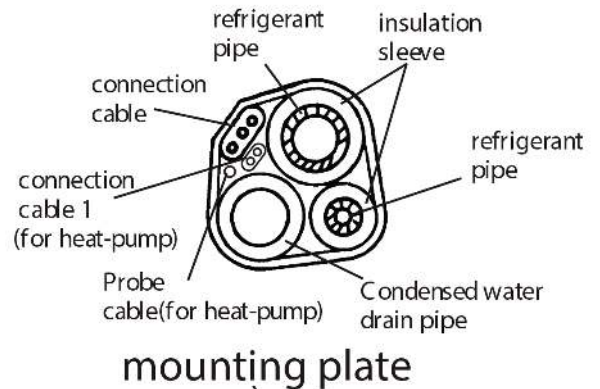
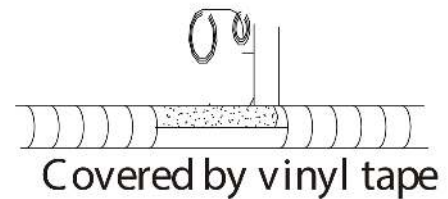
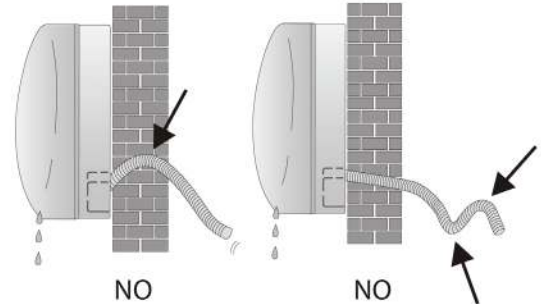

INSTALLATION INSTRUCTION (OUTDOOR UNIT)

BEFORE INSTALLING

- Locate a position with enough space and easily accessible for maintenance.
- The outdoor unit should be installed on a solid wall and fastened securely.
- Use screws and anchors that suited to the type of wall.
- Use extra screw anchors to provide extra support to the unit.
- Follow the national regulations when installing the unit.

CONDENSED WATER DRAINAGE

Condensed water and ice formed in the outdoor unit during operation need to be drained away through the drain pipe.

1. Fasten the drain port in the 25mm hole underneath the unit as shown in the picture.
2. Connect the drain port and pipe. Make sure the water is drain to a suitable place.

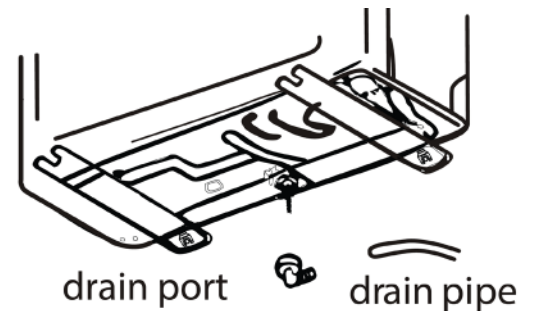

ELECTRICAL CONNECTIONS

1. Remove the right side plate
2. Connect the power cord to the terminal board. Follow the instructions on the wiring diagram which located on the back of the cover.
3. Put the cover back after connecting the wires.

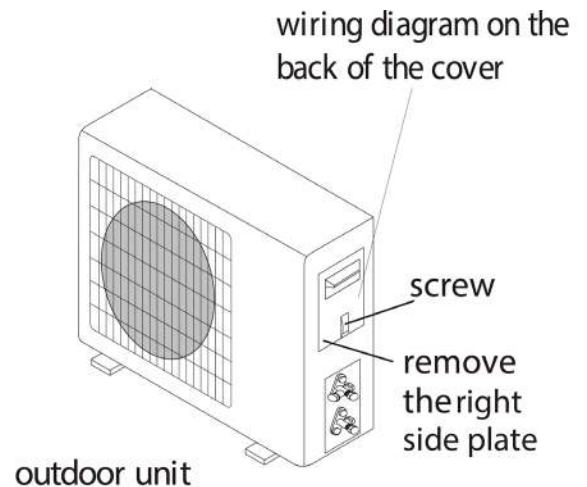

INSTALLATION INSTRUCTION (OUTDOOR UNIT)

PIPES CONNECTION

1. Connect the pipes to the outdoor unit tap by using flare nuts.
2. Tighten the flare nut. Careful not to damage the flange to prevent leakage.

BLEEDING

The air and humidity left inside the refrigerant circulation can cause compress to malfunction. After connecting the indoor and outdoor units, bleed the air and moisture from the refrigerant circulation using a vacuum pump.

1. Unscrew and remove the caps from the 2-way and 3-way valves.
2. Unscrew and remove the cap from the service port.
3. Connect the vacuum pump hose to the service port.
4. Operate the vacuum pump for 10-15 minutes until an absolute vacuum value reach 10mm Hg.
5. With the vacuum pump still in operation, close the low pressure knob on the vacuum pump coupling. Then stop the vacuum pump.
6. Open the 2-way valve by 1/4 turn and then close it after 10 seconds. Check all the joints for leaks.
7. Turn the body of the 2-way and 3-way valves. Disconnect the vacuum pump hose.
8. Replace and tighten all the caps on the valves.

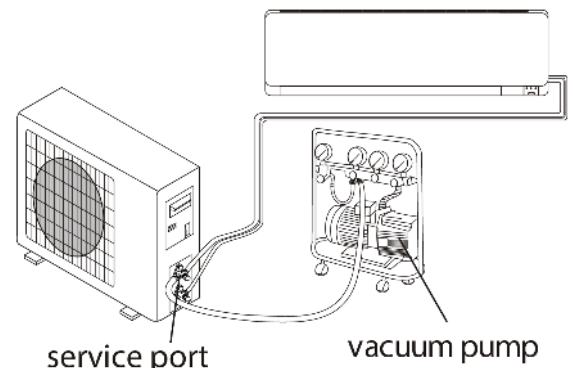
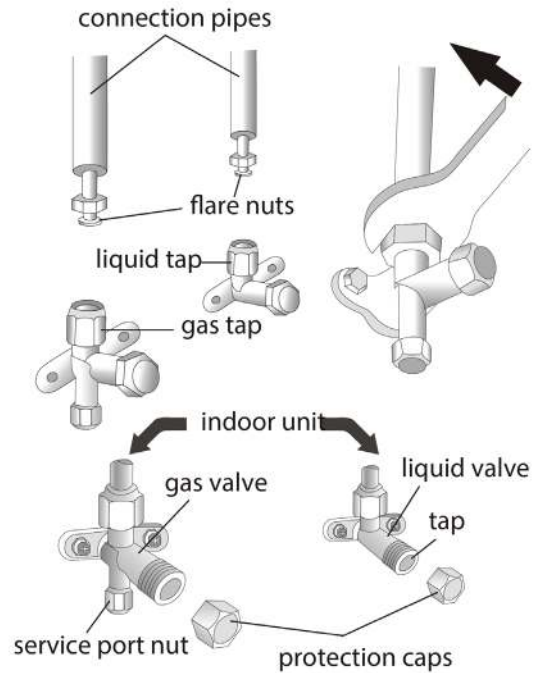

3-way valve diagram

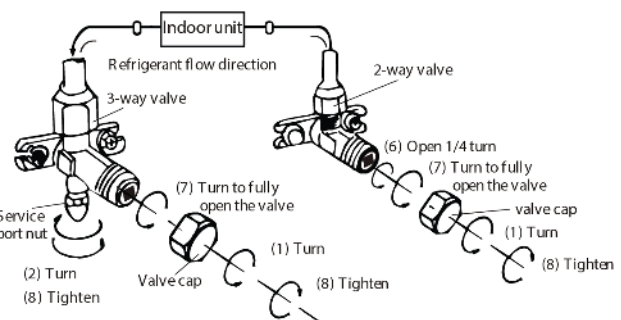
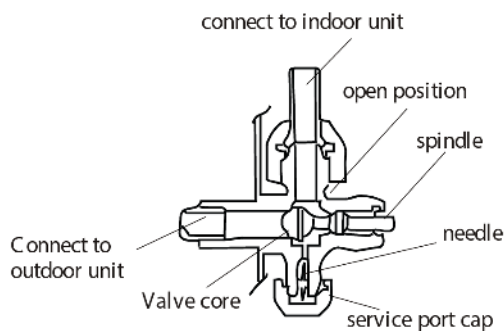

OPERATION TEST

- Place wind insulating covering around the joints of the indoor unit and secure it using insulating tape.
- Fix the exceeding part of the cable into the piping or into the outdoor unit.
- Fix the piping to the wall (after coated it with insulating tape) using clamps or insert them into plastic slots.
- Seal the hole in the wall which the piping pass through.

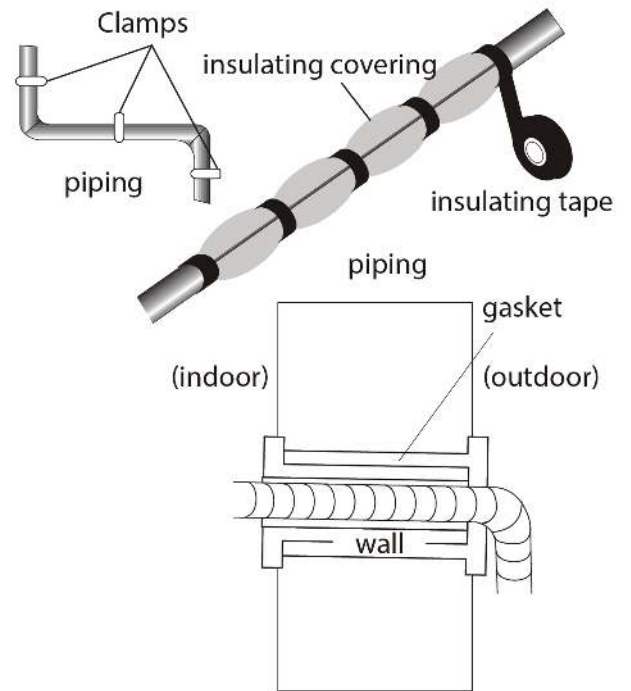

INDOOR UNIT TEXT

- Make sure the unit turn ON and OFF normally.
- Make sure the fan operate normally.
- Make sure the timer function properly.
- Make sure all indicator works properly.
- Make sure the vertical and horizontal air deflector works normally.
- Make sure condensed water drained regularly and no leakage.

OUTDOOR UNIT TEXT

- Make sure there is no abnormal noise or vibration during operation.
- Make sure the noise, air flow, or the water drainage do not disturbing.
- Make sure there is no coolant leakage.

INSTALLATION INFORMATION

MODEL CAPACITY	9k	12k		15/18k	22/24k
Liquid pipe diameter	1/4" (Φ6)	1/4" (Φ6)		1/4" (Φ6)	3/8" (Φ9.52)
Gas pipe diameter	3/8" (Φ9.52)	3/8" (Φ9.52)	1/2" (Φ12)	1/2" (Φ12)	5/8" (Φ15.88)
Length of pipe with standard charge	3m	3m	3m	4m	4m
Maximum distance between indoor and outdoor unit	15m	15m	15m	15m	15m
Additional refrigerant charge	20g/m	20g/m	20g/m	30g/m	30g/m
Max level diff. between indoor and outdoor unit	5m	5m	5m	5m	5m
Type of refrigerant	R410A	R410A	R410A	R410A	R410A

Cable Wires Specification

MODEL		9k	12k	18/22k	24k
Power supply cable	N	1.0mm ² (1.5mm ²) AWG18 (AWG16)	1.0mm ² (1.5mm ²) AWG18 (AWG16)	1.5mm ² AWG16	2.5mm ² AWG14
	L	1.0mm ² (1.5mm ²) AWG18 (AWG16)	1.0mm ² (1.5mm ²) AWG18 (AWG16)	1.5mm ² AWG16	2.5mm ² AWG14
	E	1.0mm ² (1.5mm ²) AWG18 (AWG16)	1.0mm ² (1.5mm ²) AWG18 (AWG16)	1.5mm ² AWG16	2.5mm ² AWG14
Connection supply cable	N	1.0mm ² (1.5mm ²)	1.0mm ² (1.5mm ²)	1.5mm ²	0.75mm ²
	L	1.0mm ² (1.5mm ²)	1.0mm ² (1.5mm ²)	1.5mm ²	0.75mm ²
	1	1.0mm ² (1.5mm ²)	1.0mm ² (1.5mm ²)	1.5mm ²	0.75mm ²
		1.0mm ² (1.5mm ²)	1.0mm ² (1.5mm ²)	1.5mm ²	0.75mm ²

CARE AND MAINTENANCE

Periodic maintenance is essential for keeping your air conditioner efficient.

Before carrying out any maintenance, disconnect the power supply by unplug the socket.

INDOOR UNIT MAINTENANCE

Cleaning the anti dust filters

1. Open the front panel.
2. Keep the front panel raised and take out the air filter.
3. Clean the filter with water; if the filter is soiled with oil, washed it with warm water (not exceeding 45°C)
4. Let the filter dry in a cool and dry place
5. Keep the front panel raised and insert the air filter back into the indoor unit
6. Close the front panel

The electrostatic and the deodorant filter (if installed) cannot be washed or regenerated and must be replaced with new filters after every 6 months

Cleaning the heat exchanger

1. Open the front panel and lift it at its highest height and unhook it from the hinges.
2. Clean the indoor unit using a cloth with water (not exceeding 40°C) and neutral soap. Do not use aggressive solvents or detergents.

OUTDOOR UNIT MAINTENANCE

1. If the outdoor unit is clogged, remove any debris and waste with air jet or a bit of water.

END OF SEASON MAINTENANCE

2. Disconnect the automatic switch or the plug.
3. Clean and replace the filters
4. On a sunny day, run the conditioner in ventilation for a few hours to completely dry the inside of the unit.

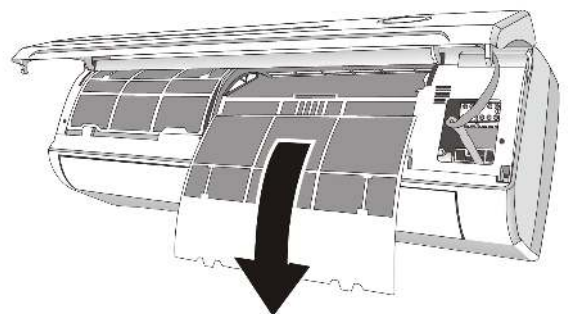
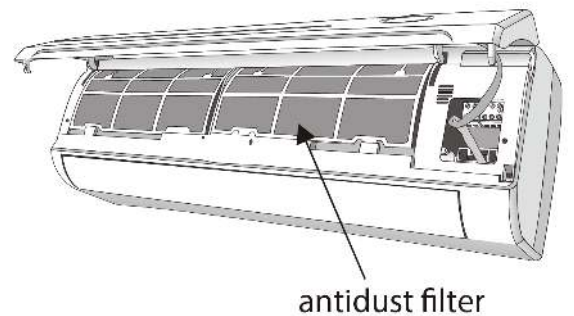
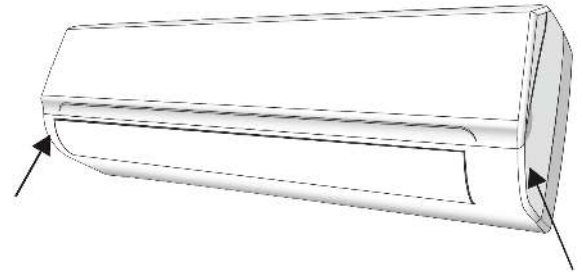

TROUBLESHOOTING

MALFUNCTION	POSSIBLE CAUSES
The Appliance does not work	Power failure / not plugged into power source
	Damaged indoor / outdoor unit fan motor
	Faulty compressor thermo-magnetic circuit breaker
	Faulty protective device or fuses
	Loose connections
	Self-protective feature
	Voltage too high or too low
	Active timer-on function
	Damaged electronic control board
Strange odor	Dirty air filter
Running water noise	Liquid black flow in the refrigerant circulation
Mist come out from the air outlet	This occurs when the air in the room becomes very cold, for example in the “cooling” or “dehumidifying / dry” modes
Strange noise can be heard	This noise is made by the expansion or contraction of the front panel due to variations in temperature and does not indicate a problem
Insufficient airflow, either hot or cold	Inappropriate temperature setting
	Air inlet or outlet has been blocked
	Air filter is clogged
	Fan speed set at low
	Other heat sources in the room
	No refrigerant
The appliance does not respond to commands	Remote control is not near enough to indoor unit
	Battery in Remote controller may have been exhausted
	Obstacles between remote control and the indoor unit signal receiver
The display is off	Power failure

TROUBLESHOOTING

Switch off the air conditioner immediately and cut off the power supply in the event of:

Strange noises during operation

Faulty electronic control board

Faulty fuses or switches

Spraying water or objects inside the appliance

Overheated cables or plugs

Very strong smells coming from the appliance

Error signals on the display

In case of error, the display on the indoor unit shown the following error codes:

	RUN indicator	Description
E1	Flashes once	Faulty indoor temperature sensor
E2	Flashes twice	Faulty indoor pipe temperature sensor
E6	Flashes 6 times	Malfunction indoor fan motor

