

071R9846

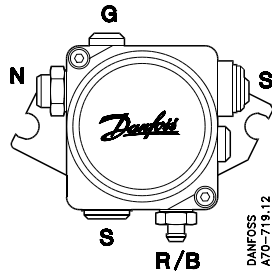

Fig. 1

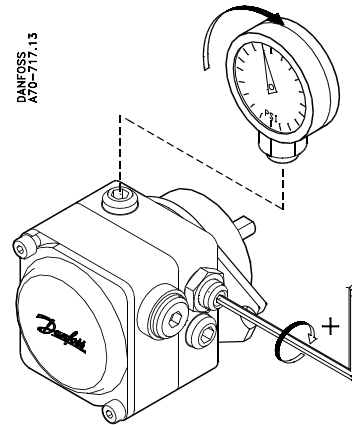
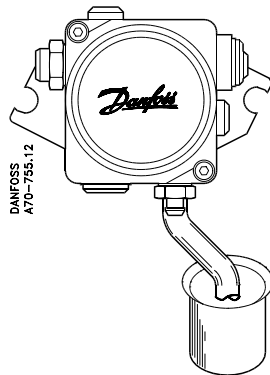

Fig. 3



Bleeding: Open bleeder max. 1/2 turn

Fig. 2

Strainer shift

- 1) Loosen screws about 1 turn
- 2) Turn cover CCW and pull

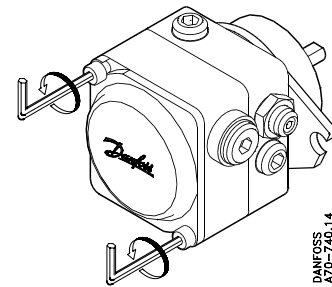

Technical data

Oil types: Fuel #2 or lighter fuel up to B 10

Pressure: With fuel #2:

100-160 psi, 1725 rpm, 3 gal/h

100-210 psi, 3450 rpm, 3 gal/h

With lighter fuel:

Model 3450 rpm: 100-210 psi,

2 gal/h, 100-150 psi, 3 gal/h

Model 1725 rpm: 100 psi, 3 gal/h

Factory setting: 100 psi

Strainer capacity: 3 gal/h

Connection fig. 1

The fuel unit is to be connected as follows:

N = Nozzle port 1/8" NPTF

G = Pressure gage port 1/8" NPTF

S = Suction port/vacuum gage port
1/4" NPTF

R/B = Return port/bleed port
1/4" NPTF

Air bleeding fig. 2

Bleeding is only necessary for 1-pipe systems. In the case of 2-pipe systems, the unit bleeds the system automatically through the return line.

Bleed plug

The type BFPH fuel unit has a combined return and bleed plug. If an installation has to be altered from two pipe into one pipe, close the return port with original return/bleed or any standard 1/4" NPT plug.

Pressure adjustment fig. 3

Mounting

Avoid mounting with the shaft pointing upwards.

Avoid mounting with nozzle outlet pointing upwards in 1-pipe systems with lift.

Check of cut-off

The cut-off may be checked by mounting a gage in the nozzle port. There must be a residual pressure when the burner is shut down. The size of this residual pressure should not be taken as an expression of the quality of the cut-off.

The quality of the cut-off can be checked only by looking at the flame at shut down. The nozzle line must be totally purged.

Automatic By-pass

The type BFPH fuel unit can operate on one pipe or two pipe installations. Use of a by-pass plug is not required.

Caution

Maximum pressure on inlet and return line at the fuel unit must not exceed 30 psi.

A pressure greater than that may cause damage to the shaft seal. Non-hardening oil pipe dope is recommended for all thread connections, as teflon tape pieces may cause troubles in pump and nozzle. It is suggested that a quality filter is installed in the supply line.

Do not use check valves or equivalent components in oil lines or restrict oil flow back to the supply tank by any means, (especially not in gravity feed systems), unless a means of pressure relief is installed. Thermal expansion of the oil during off-cycle/burner shut-down can create high pressure within the supply line that can cause damage to the shaft seal and/or cover of the fuel unit, or to the piping.

071R9846

High pressure relief function

Notice!

BFPH fuel units produced after June 17th 2002, date code 252, have a high pressure relief function under the cover to protect the fuel unit and system against high pressure. The high pressure relief function releases a few drop-lets of oil at the cover when the pressure in the oil lines reaches more than 100 psi. After the high-pressure is relieved, the relief function closes and the fuel unit is tight.

If the high pressure relief function has been activated it is a clear indication that there is a problem in the system that results in pressure build up. This can happen by e.g. thermal expansion of oil or a supply pump with the supply pressure set too high. Check the system for:

- Water contamination (risk of ice plugs and thermal expansion of oil).

- Check valves or other restrictions in the line/lines without proper pressure relief back to tank.
- Supply pressure setting in systems with supply pump.
- Any other restriction that has occurred.
- Ensure that outdoor piping is sufficiently insulated.

All installations must be in accordance with National and Local Codes.

One pipe system

Suction line length

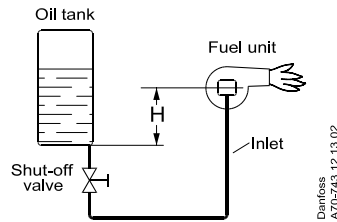

Maximum one-pipe lift = 8 feet

Line length in feet including vertical and horizontal length:

H = Head in feet

Q = Firing rate (Actual nozzle output) in gal/h

$$\frac{3}{8}'' \text{ line length} = \frac{6 - 0.75H}{0.0086 Q} = \text{feet}$$

$$\frac{1}{2}'' \text{ line length} = \frac{6 - 0.75H}{0.00218 Q} = \text{feet}$$

If tank is above fuel unit change - to +

Two pipe system

Suction line length

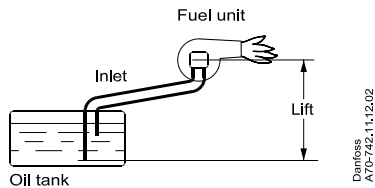

Calculation basis:
Viscosity 57 SSU = 9.6 cSt.
Tube wall thickness .035"

Suction line length in feet including vertical and horizontal length

Pump size	3 gal/h			
	1725 rpm		3450 rpm	
Lift Feet	$\frac{3}{8}''$ OD tubing	$\frac{1}{2}''$ OD tubing	$\frac{3}{8}''$ OD tubing	$\frac{1}{2}''$ OD tubing
0'	150	150	91	150
2'	132	150	80	150
4'	114	150	68	150
6'	94	150	57	150
8'	74	150	45	150
10'	57	150	34	134
12'	37	150	23	90
14'	19	75	-	45

Spare part list

	Code no.
Strainer	071N1392
O-ring for cover sealing	633B0090
Bleed plug	071N1011

Danfoss Hago Inc.

1120 Globe Avenue
Mountainside, NJ 07092 USA
Telephone: (908) 232-8687
Fax: (908) 232-7246
E-mail: hago@danfoss.com
www.hago.danfoss.com

Danfoss shall not be responsible for any errors in catalogs, brochures or other printed material. Danfoss reserves the right to alter its products at any time without notice, provided that alterations to products already on order shall not require material changes in specifications previously agreed upon by Danfoss and the Purchaser. All trademarks in this material are property of the respective companies. Danfoss and the Danfoss logotype are trademarks of Danfoss A/S. All rights reserved.