

User Guide

Electronic Refrigeration Controller

ERC 112D VSC for variable speed compressor

This user guide is intended to be used by OEMs for the purpose of programming ERC 112D VSC. It may also be useful for technicians. However, it is not intended as a user guide for end users.



Introduction

Application

Temperature control for refrigeration appliances.
Speed control of variable speed compressor.
Front panel mounting.



Advantages

The latest generation CPU, plenty of memory and high-end electronic components allow for a uniquely versatile software. Three separate password-protected user levels can be used to control more than 300 different parameters to fit all individual requirements.

Approvals

R290/R600a end-use applications employing in accordance to EN/IEC 60335-2-24, annex CC and EN/IEC 60335-2-89, annex BB;
Glow wire according to EN/IEC 60335-1;
IEC/EN 60730
UL60730
NSF
CQC
EAC
Ukraine

Password protected

The access level can be set separately for each parameter using KoolProg Software Tool.
There are three levels of access 1, 2, 3:
- level 1 is for shop access;
- level 2 for technicians;
- level 3 for OEMs.
The access levels cannot be set using the buttons. Passwords for the different levels can however be altered for the level of access you have, e.g. a level 2 user can change the password for level 1 and level 2 but not level 3.

Typical application

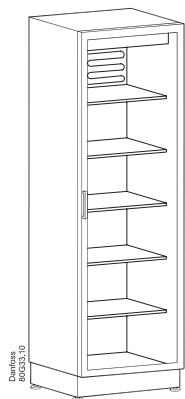

Glass Door Merchandiser
No-frost freezer/sub-zero cooler

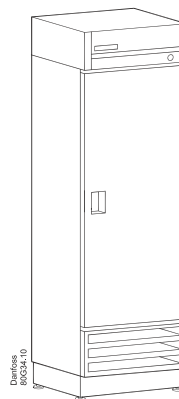

Gastro
No-frost freezer/Cooler

ERC 112D VSC

080Gxxxx PV0X

100-230Vac ±10%, 50/60Hz 0T55

xxx Display

*Outputs:

1	2	3	4	5	6
D01	L	N	D02	D03	D04

*Inputs:

S1	S2	S3	S4	di
Analog/ Digital				Comm.
Freq. o/p				

*Other functions see instruction

Rating:

Relay				
	240 Vac	120 Vac	240 Vac	
D01	10A,10FLA/60LRA	16FLA/72LRA	16(16)A	
D02	8A, 2FLA/12LRA	TV-1	8A, 2(2)A	
D03-D04	2A, 2FLA/12LRA	TV-1	Max 10A total D02-4	

Product overview

Display



The ERC 112D VSC is an electronic refrigeration controller with an LED display especially developed for bottle coolers and commercial fridges and freezers where a Variable speed compressor is installed. It is particularly suited for OEM customers where time, easy and reliable installation and high quality need to go hand in hand with flexibility.

Buttons

The upper left button is "Defrost".
The lower left button is "Super chill".

Clips



Are used to secure the controller in place in the case of rear mounting. They are not used with front mounting. There are two identical clips, one placed on either side of the controller.

Front frame

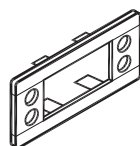

The front frame provides a proper finish but can also be used to secure the controller in place when using front mounting. In this case, clamps are not required. Contact Danfoss for details.

"S1"

Temperature sensor for cabinet

"S2"

Temperature sensor for defrost

"S3"

Temperature sensor for condenser, light sensor or Motion sensor

"S4"

Frequency signal for variable speed compressor.
5 V, 0-200 Hz

"di"

Door signal or Motion sensor

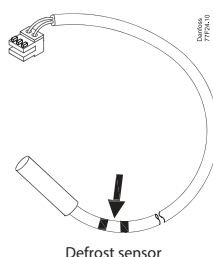
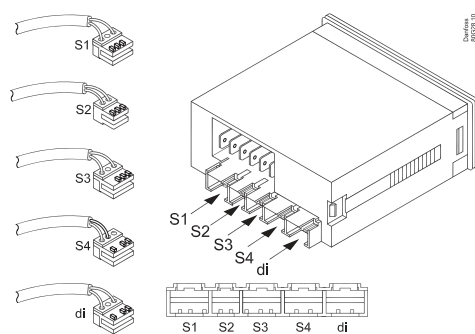

Control temperature sensor

There are different lengths.

Defrost temperature sensor

Should be mounted on the evaporator.

Condenser temperature sensor

Should be mounted on the condenser.

Light sensor

Is optional and is used to measure the level of ambient light around the cabinet so that night and day "Economy", "Normal" modes of operation can automatically be set, as well as the brightness of the display.

Frequency Signal

Connected to variable speed compressor drive frequency input port.

Motion sensor

Should be mounted on the cabinet front.

Door sensor connector cable

Is optional and is a connector and cable with spade terminals compatible with door contacts used in refrigeration applications.

The function of an input can be reprogrammed, but the connector can not be moved. The connector is designed to only one location. "S1" to "S1", "S2" to "S2", etc.

Quick programming

Software for PC



KoolProg

Software from Danfoss for programming the ERC-controller via a PC rather than with the front panel buttons.

<https://www.danfoss.com/en/service-and-support/downloads/dcs/koolprog/>

USB gateway



USB gateway

The USB Gateway is a laboratory tool, offering fast and easy programming of any ERC controller connected directly to the PC.

"KoolProg Software" installation kit is provided for the PC. The gateway is standard inventory for OEM labs.

USB programming key



Programming an individual unit in a laboratory

The USB key requires "KoolProg Software" running on a PC. It enables parameters to be set in real time and an array of status information to be read (bidirectional connection).

Once the desired settings have been determined, a specific parameter file is saved to the USB key for later mass programming through the docking station.

Docking station



Mass programming on an assembly line:

The docking station is used for high volume programming of ERC controllers, for example on an assembly line. The docking station is a write-only device.

The USB key, is to be inserted into the docking station. The settings are then loaded into each successive controller in a matter of seconds. "KoolProg Software" is not required for mass programming.

Technical specs

Power Supply	100 - 240 V AC Switch mode power supply. Average 0.7 W		
Purpose of control	To control commercial Refrigeration Applications using variable speed compressor		
Construction of Control	Electronic control for incorporation for use in Class I and Class II appliance		
Automatic Action	Micro- disconnection on operation type 1.B		
Input	4 inputs: 3 analogue (digital), 1 digital; user specific assignment		
	• Cabinet air/Evaporator/Condenser	• Door sensor: all types, user specific	
	• Light sensor: Danfoss ECO light sensor	• Motion sensor	
Output		UL60730	EN60730
	"DO1"	120 V AC: 16 A resistive/FLA16/LRA72 240 V AC: 10 A resistive/FLA10/LRA60	16(16) A
	"DO4"	8 A resistive, FLA2/LRA12, TV-1	8 A resistive, 2(2) A
	"DO5"	FLA2/LRA12, TV-1	8 A resistive, 2(2) A
	"DO6"	FLA2/LRA12, TV-1	8 A resistive, 2(2) A
			Max 10 A total "DO4-6"
	S4: Frequency Signal for Variable speed 5 V, 0-200 Hz		
Probes	Danfoss NTC sensors and Danfoss ECO accessories (Light, Motion and Door sensors)		
Connectors	Modular connector system for OEM customers, with optional output screw terminal adapter; S1-S4 & Di: RAST 2.5 edge, DO1-DO4, Line & Neutral- RAST 5 standard		
Programming	Programming with Danfoss PC software, gateway, EKA 183A		
Assembly	Front mounting; Brackets		
Display	LED display, 3 digit, decimal point and multi functionality icons; °C/°F scale		
Keypad	4 buttons (integrated IP65 design), 2 left, 2 right; user programmable		
Operating Conditions	0°C – 55°C, 93% rH		
Storage Conditions	-40°C – 85°C, 93% rH		
Range of Measurement	-40°C – 85°C		
Protection	Front: IP65 Rear: water and dust protection corresponds to IP31, accessibility of connectors limit rear part rating to IP00		
Environmental	Pollution degree II, non-condensing		
Resistance to heat & fire	Category D (UL94-V0)		
EMC category	Category I		
Over Voltage Category	Category II (IEC 60664-1)		
Temperature for Ball Pressure Test	According to EN 60730-1, Annex G		
For SELV Circuits	Input Probes or Digital Input connected to SELV limited energy >15W		
Operating Cycles	Main relay: more than 175,000 at full load (16A (16A))		
Approvals	R290/R600a end-use applications employing in accordance to EN/IEC 60335-2-24, annex CC and EN/IEC 60335-2-89, annex BB Glow wire according to EN/IEC 60335-1 IEC/EN 60730 UL60730 NSF CQC EAC Ukraine		These approvals are only valid when used with recommended Danfoss accessories.

IMPORTANT NOTE

The inputs and frequency signal port are not galvanic isolated and are connected directly to the mains supply! For that reason, door-switches, sensors as well as the cables must fulfil the reinforced insulation requirements.

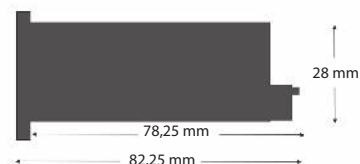
Dimensions

Front mounting
(Lock with frame)

Rear mounting
(Lock with clips)

Connections

(Inputs and outputs are configurable)

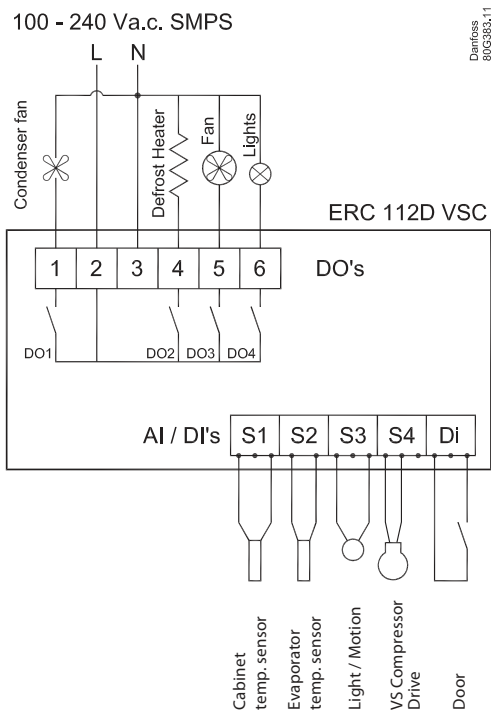
Application:
Light / Motion, Door



Application:
Condenser, Door / Motion

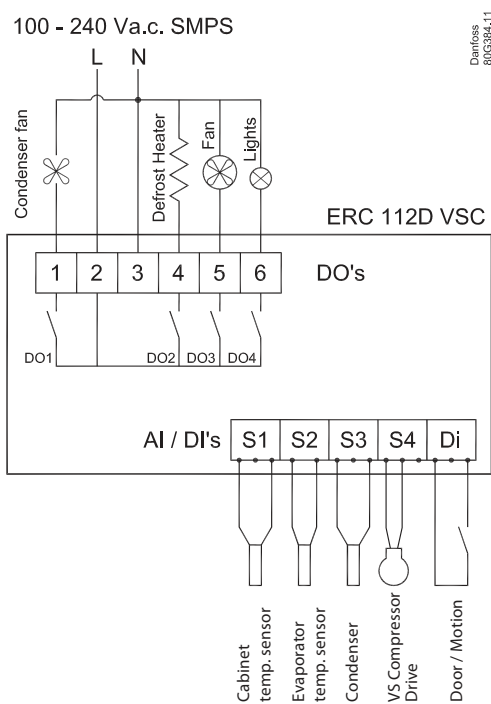

Code numbers

Type	I-Pack	
	Qty.	Code no.
ERC 112D VSC, Blue LED, with buzzer	27	080G3414
Temperature sensors		
<i>-40 – 80 °C, PVC Standard, NTC 5 K</i>		
S1, 470 mm, 3-pole	120	077F8751
S1, 1000 mm, 3-pole	120	077F8757
S1, 1500 mm, 3-pole	120	077F8761
S1, 2000 mm, 3-pole	120	077F8765
S1, 2200 mm, 3-pole	120	077F8767
S1, 3000 mm, 3-pole	60	077F8769
S1, 3500 mm, 3-pole	60	077F8723
S1, 6000 mm, 3-pole	27	080G2019
<i>-40 – 120 °C, TPE precision NTC 5 K, Santroprene</i>		
S1, 1500 mm, 3-pole	120	077F8726
S1, 2000 mm, 3-pole	120	077F8727
<i>-20 – 200 °C, Silicone rubber cable, NTC 100 K</i>		
S1/S3, 2000 mm, 3-pole	108	080G2043
<i>-40 – 80 °C, PVC Standard, NTC 5 K</i>		
S2, 1000 mm, 2-pole	120	077F8786
S2, 1500 mm, 2-pole	120	077F8790
S2, 2000 mm, 2-pole	120	077F8794
S2, 3000 mm, 2-pole	60	077F8798
S2, 6000 mm, 2-pole	27	080G2029
S3, 1000 mm, 3-pole	120	077F8756
S3, 1500 mm, 3-pole	120	077F8760
S3, 2200 mm, 3-pole	120	077F8766
S3, 3000 mm, 3-pole	60	077F8768
S3, 6000 mm, 3-pole	27	080G2039

Type	I-Pack	
	Qty.	Code no.
Light-sensors		
S3, 1000 mm, 3-pole	108	080G3311
S3, 2000 mm, 3-pole	108	080G3313
S3, 3000 mm, 3-pole	108	080G3315
Cable, variable speed compressor		
S4, 3500 mm, 3-pole	81	080G3397
Magnetic door sensor		
di, 1000 mm, 3-pole	81	080G3320
di, 2000 mm, 3-pole	81	080G3322
di, 3000 mm, 3-pole	81	080G3324
Cable door sensor		
di, 1000 mm, 3-pole	108	080G3340
di, 2000 mm, 3-pole	108	080G3341
di, 3000 mm, 3-pole	108	080G3342
di, 4000 mm, 3-pole	81	080G3343
Motion sensor		
S3/di, 3000 mm, 3-pole	27	080G3392
Clips		
Black (2 needed per controller)	54	080G3308
Programming		
OEM Docking station, production line	1	080G9701
Gateway incl USB Cable, R&D	1	080G9711
Programming key EKA183A	1	080G9740
Power plug *		
6-pole with screw	54	080G3357

* The connectors are rated for 28 Amps max.

Sx (di)= connector position.
Inputs are configurable.

Note: For more information about temperature sensor types and connectors, please refer to Danfoss' technical brochure "NTC type temperature sensors for ETC & ERC controllers".

Operation

Software tool/Gateway

The controller can be controlled in three ways: Using "KoolProg Software", the Danfoss Docking Station or manually by means of the buttons on the front panel.

"KoolProg Software" is licenced Danfoss software offering easy parameter set up via a USB gateway. This software is supplied separately; for technical literature and further information, please contact your local Danfoss representative.

Docking station

Docking station is supplied separately. For further information, please contact your local Danfoss representative.

Manual operation with buttons (Direct Access)

1 Press: variable direct function, e.g. "Defrost"
Sub function: back

1 Press: variable direct function, e.g. Super Chill
Sub function: "OK"



1 Press: temperature set point
Sub function: "up"

1 Press: temperature set point
Sub function: "down"

Examples

Changing the Desired Temperature Set point:

1. The display shows the current temperature.
2. Press "up/down" to access set point.
3. Press "up/down" to adjust set point.

After 30 seconds, the display automatically reverts to showing the current temperature

Acknowledging Alarms:

1. Display Flashing the alarm message.
2. Press any button to acknowledge.

Password protection:

1. Press "^" and "v" together and hold 5 seconds to access the menu.
2. The display shows "PAS" (only if configured for password protection).
3. Press "OK".
4. Press "^"/"v" to the code.
5. Press "OK".

Password protection on three levels:

1. Level 1: "shop" (daily use by shop personnel).
2. Level 2: "ser" (service technician).
3. Level 3: "OEM" (OEM programming).

Changing a Parameter

Some parameters may be hidden to you. Your access level will determine which parameters you can view and edit:

1. Press "^" and "v" together and hold 5 seconds to access the menu.
2. First parameter group is shown "tHE".
3. Press "^" and "v" to find the desired group.
4. Press "OK".
5. First parameter is shown.
6. Press "^" and "v" to find the desired parameter.
7. Press "OK".
8. Press "^" and "v" to find the desired setting.
9. Press "OK".

After 30 seconds, the display automatically reverts to showing the current temperature. Or Press 2 x "Back".

NOTE:

Incorrect parameter settings can lead to inadequate cooling, excessive energy consumption, unnecessary alarms and in the case of temperature-sensitive food storage, breaches in food hygiene principles and regulations.

Only a trained operator should make changes to parameters.

Menu/functions

ERC menu code		Description
"tHE"		Thermostat settings
"SEt" Min. -100.0°C Max. 200.0°C Default 2.0°C	Set point This parameter defines the desired temperature (set point). In standard operation the set point is changed by simply pressing the "temperature up/down" buttons on ERC 112D VSC; for laboratory and assembly line you may opt for software controlled set point adjustment (speed improvement)	
"SPr" Min. 0.0 Max. 1.0 Default 0.5	Current set point adjustment value diF * SPr The default value is set to 0.5 and the parameter is hidden by default. "Spr" defines the position of the set point in relation to cut-in and cut-out. "Spr=0,5" sets the set point mid between cut-in and cut-out. "Spr=0" sets the set point at the cutout. "Spr=1" sets the set point at cut-in.	
"diF" Min. 0.0 K Max. 20.0 K Default 2.0 K	Thermostat differential This defines the difference between the cut-out and the cut-in. The desired temperature is determined by "Spr" and "diF".	
"HSE" Min. -100.0°C Max. 200.0°C Default 50.0°C	Upper limit of thermostat set point Define the temperature range limit of the controller. Once set, the desired temperature (set point) can not go above "HSE" or below "LSE".	
"LSE" Min. -100.0°C Max. 200°C Default -35.0°C	Lower limit of thermostat set point Define the temperature range limit of the controller. Once set, the desired temperature (set point) can not go below "LSE".	
"iCt" Min. no Max. yes Default no	Initial cut in This parameter is to set the refrigeration system action when cab air temperature is between cut-in and cut-out at power up. yES : Switch on the refrigeration system immediately. no: Keep the refrigeration system off until cab air temp reaches cut in temperature.	
FAn		Fan settings
"FCt" Default FAo	Fan control method "FAo": fan always on "SEt": fan follow compressor by manual settings. (FoC and FSC needs to be set accordingly) "Aut": automatical fan control	
"Fod" Min. 0 s Max. 240 s Default 0 s	Fan ON Delay/Fod Fod defines the fan delay (in seconds) after a compressor cut-in.	
"FSd" Min. 0 s Max. 240 s Default 0 s	Fan Stop Delay/FSd "FSd" defines the fan delay after a compressor cut-out. If both "Fod" and "FSd" are set to zero then the fan runs whenever the compressor runs.	
"FoC" Min. 0 s Max. 960 s Default 0 s	Fan ON Cycle/FoC Fan Stop Cycle/FSC When the compressor is OFF, and "FoC" or "FSC" are not zero, the fan runs in cycles according to "FoC" and "FSC".	
"FSC" Min. 0 s Max. 960 s Default 0 s	Example: "FoC=120" [sec] and "FSC=120" [sec] means that the fan runs for half the time when the compressor is OFF. When the compressor is on, the fan is always ON (according to "FAo" and "Fod").	
"FSt" Min. 0 s Max. 960 s Default 10 s	Fan Minimum Stop time Minimum stop time for fan protection.	
"FdC" Min. -10.0 K Max. 10.0 K Default 0.0 K	Fan Δt cut in (This parameter is only applicable with Automatic fan control "Aut" mode.) Delta T for fan to cut in which the temperature offset comparing with thermostat cut in temperature.	

	"Fdt" Min. 0 s Max. 999 s Default 0 s	Fan stop time on door open The delay with wich the fan will be stopped after the door has been opened. "0": fan stop immediately when door open. "1-998": delay for fan stop after door open. "999": fan keep running all the time during door open.
	"FLt" Min. 0°C Max. 50°C Default 50	Fan limit temperature This function prevents the evaporator fan to operate if the temperature is above the fan limit temperature. If the defrost sensor registers a higher temperature than the one set here, the fan will be stopped to avoid the warm air circulation in the cabinet. This parameter is active only when evaporator sensor is connected.
	"FdF" Min. 1 K Max. 10 K Default 2	Fan limit Delta temperature This is the evaporator delta temperature for the fan to switch ON after it is switched off due to FLt setting.
Lig	Light settings	
	"CLC" Min. on Max. dor Default on	Cabinet Light Source Control This parameter can be set to one of these alternatives to control the light in the cabinet: "on": always ON. "oFF": always OFF. "dor": door sensor only.
	"Lod" Min. 0 s Max. 300 s Default 0 s	Light OFF delay Number of seconds the light will stay ON after the door has been closed.
Pud	Pull Down settings	
	Pull down (sometimes known as Super Cool) is a procedure for improving cooling performance, accelerating the time used to reach the desired temperature. Pull down settings overrule all other settings.	
	"Pit" Min. -40.0°C Max. 50.0°C Default 50.0°C	Pull Down Initiate Temperature This parameter indicates the temperature which causes a pull down to start. If the temperature measured inside the cabinet exceeds this value for longer than one hour, then pull down will start. During this period compressor will run at maximum speed and stop defrost cycles until the desired temperature (PLt) is reached or pull down duration (Pdd) expires. The period of one hour is fixed and cannot be altered.
	"PCy" Min. 0 min Max. 360 min Default 30 min	Pull Down Cycling This is the duration in minutes of the compressor cycling at the reduced set point temperature. Once the desired pull down limit temperature "PLt" has been reached during pull down, the compressor will continue to cycle ON/OFF for the duration of "PCy". At the end of the period defined by "PCy", the set point temperature will return to normal and pull down will cease.
	"Pdi" Min. 0 hour Max. 48 hour Default 15 hour	Pull Down Defrost Interval This is the time between defrost cycles during pull down. It is measured in hours and can be up to 48 hours. During pull down, this setting overrides the normal defrost interval settings.
	"Pdd" Min. 0 hour Max. 48 hour Default 24 hour	Pull Down Duration Maximum time for pull down. If time expires pull down will stop, regardless of temperature.

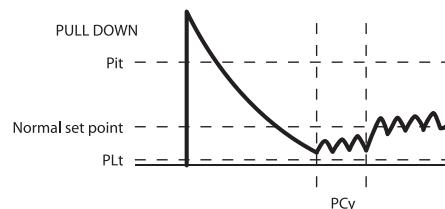
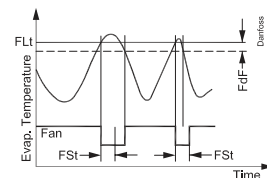

	"PLt" Min. -55.0°C Max. 55.0°C Default 0.0°C	Pull Down Limit Temperature This parameter sets the minimum allowed temperature during pull-down. In order to protect valuable contents you must always specify the absolute minimum temperature allowed in your application. For glass door merchandisers 0°C/32°F protects bottles from freezing; for commercial fridges you may opt for a slightly higher temperature (e.g. 2°C)
	"Prt" Min. 0.0 K Max. 10.0 K Default 0.1 K	Pull Down Reduction Temperature Δt The controller calculates a lower set point during pull down mode to increase the cooling capacity of your appliance. For each hour the cabinet temperature is above the pull down initiate temperature, the set point is reduced with the value of "Prt".
	"PAAd" Min. 0 min Max. 999 min Default 30 min	Pull down duration after defrost Special pulldown duration after every defrost for faster cooling of the cabinet. During this period compressor will run at maximum speed. If configured "0" this feature is disabled.
dEF		Defrost settings
	"dFt" Default no	Defrost Type "no": defrost function is disabled. "EL": electrical defrost. "Hgd": hot gas defrost (contact Danfoss for details). "nat": OFF-cycle defrost (natural defrost).
	"Add" Min. no Max. yes Default no	Adaptive defrost "no": defrost controlled by time. "yES": automatic defrost control activated.
	"dtt" Min. 0.0°C Max. 25.0°C Default 6.0°C	Terminate Temperature This parameter defines at what temperature the defrost cycle will stop. The temperature is given by the evaporator sensor or by the cabinet temperature sensor if no evaporator sensor is used.
	"drt" Min. 0.0°C Max. 200.0°C Default 5.0°C	Defrost reset temperature The defrost counter is saved and restored at power-up, but if the temperature sensor, used for defrost, is higher than this value at power-up and between minimum and maximum defrost interval, it is assumed that the evaporator is free of ice and the defrost counter will be cleared.
	"dii" Min. 1 hour Max. 96 hour Default 6 hour	Defrost minimum Interval/dii Defines the minimum time period between the start of two defrost cycles. This parameter is applicable only in Adaptive defrost mode. Once the minimum interval has expired, controller will monitor the evaporator temperature and it will start the defrost if evaporator temperature goes below "dEt" or "dtt" value. If not, it will trigger the defrost once the maximum interval "dAi" has been reached. In case of time based defrost it always trigger the defrost at Maximum interval"dAi".
	"dAi" Min. 1 hour Max. 96 hour Default 7 hour	Maximum Interval Defines the maximum time period between the start of two defrost cycles.
	"dit" Min. 0 min Max. 240 min Default 5 min	Minimum Time Defines the minimum duration of a defrost cycle. During this period, the controller will not check the temperature. Once the minimum time has expired, the temperature will be checked and if the terminate temperature "dtt" has been reached, the defrost cycle will end. If dtt has not been reached, defrost will continue until either dtt is reached or the maximum time "dAt" reached, whichever occurs first.
	"dAt" Min. 0 min Max. 480 min Default 30 min	Maximum Time Defines the maximum duration of a defrost cycle. The controller will not allow a maximum time to be entered which is less than the minimum time, or a minimum time which is more than the maximum time.

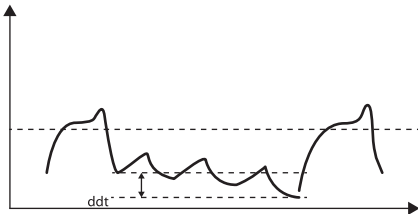
<p>"dot"</p> <p>Min. 0 min Max. 60 min Default 0 min</p>	<p>Drip OFF Time</p> <p>This parameter can be set to between 0 and 60 minutes and defines how long the delay is between the heater being switched OFF and the compressor starting again. Drip off time is generally configured to ensure there is no water droplet on the evaporator coil before starting the cooling cycle.</p>
<p>"Fdd"</p> <p>Min. 0 s Max. 600 s Default 0 s</p>	<p>Fan Delay after Defrost</p> <p>Defines how long the delay is between the start of the compressor after defrost and the fan starting again.</p>
<p>"Ftd"</p> <p>Min. -25.0°C Max. 25.0°C Default 25.0°C</p>	<p>Fan Start Temperature</p> <p>This only applies if an evaporator temperature sensor is fitted. This parameter determines at what evaporator temperature the fan will start after a defrost cycle is complete. If the time set in "Fdd" occurs before the temperature set in "Ftd", the fan will start in line with "Fdd". If the temperature set in "Ftd" occurs first, then the fan will start in line with "Ftd". It is therefore a case of whichever parameter's setting is reached first which determines when the fan starts.</p>
<p>"dFA"</p> <p>Min. no Max. yes Default no</p>	<p>Defrost Fan On</p> <p>Set to "yes", the fan will constantly run during defrost cycles. Set to "no", the fan will not run during defrost cycles.</p>
<p>"dCt"</p> <p>Min. no Max. yes Default no</p>	<p>Defrost on compressor run time</p> <p>Yes: Defrost interval is based on accumulated compressor run time. No: Defrost interval is based on elapsed time.</p>
<p>"doC"</p> <p>Min. 0 hour Max. 24 hour Default 0 hour</p>	<p>Defrost by continuous compressor running time.</p> <p>If compressor is running continuously more than this time, controller will trigger the defrost, this is a safety feature to ensure continuous compressor running is not due to clogged evaporator. "0"= Feature deactivated</p>
<p>"dEt"</p> <p>Min. -50.0°C Max. 0.0°C Default -50.0°C</p>	<p>Defrost start evaporator temp</p> <p>Defrost will get triggered at this temperature after expiry of minimum defrost interval "dii".</p>
<p>"ddt"</p> <p>Min. 0.0 K Max. 30.0 K Default 5.0 K</p>	<p>Defrost Δt</p> <p>Defrost Δt compare with evaporator temperature of first cut out after defrost to trigger defrost start. The defrost start if evaporator temperature has decreased more the "ddt"</p> 
<p>"idd"</p> <p>Min. 0 hour Max. 96 hour Default 3 hour</p>	<p>Initial Defrost Interval</p> <p>The initial defrost interval determines the time for first defrost after power-up. The initial defrost is mainly intended for factory testing of the defrost functionality and can be set to expire after a number compressor cycles according to the setting of parameter idd. During normal operation, the defrost counter will be saved in memory and restored after power loss, making the initial defrost unnecessary.</p>
<p>"idd"</p> <p>Min. 0 Max. 999 Default 100</p>	<p>Initial Defrost Duration</p> <p>The initial defrost duration is the number of compressor cycles before the initial defrost is deactivated. "0": "idd" No initial defrost. "1-998": number of compressor cycles before deactivation. "999": initial defrost always active.</p>

CoP		Compressor settings
	"CSL" Min. 50 rpm Max. 500 rpm Default 200 rpm	Min speed Minimum operating speed of variable speed compressor. The actual rpm is multiplied by 10 to the selected value, hence read actual rpm=value*10.
	"CSH" Min. 50 rpm Max. 500 rpm Default 450 rpm	Max speed Maximum operating speed of variable speed compressor. The actual rpm is multiplied by 10 to the selected value, hence read actual rpm=value*10.
	"CSS" Min. 50 rpm Max. 500 rpm Default 200 rpm	Start speed Start speed is the speed at compressor must start before changing to the requested speed to ensure the proper lubrication. The actual rpm is multiplied by 10 to the selected value, hence read actual rpm=value*10.
	"HdS" Min. 50 rpm Max. 500 rpm Default 200 rpm	Hot gas Defrost Speed Required compressor speed during hot gas defrost. The actual rpm is multiplied by 10 to the selected value, hence read actual rpm=value*10.
	"CtP" Min. 0 % Max. 100 % Default 100 %	Cabinet Temperature Percentage If compressor is controlled based on the weighted average temperature of cabinet air and evaporator sensors, this parameter defines the percentage of cabinet air temperature to be considered for the calculation of weighted average temperature. For example, CtP= 40% , SCo=5°C and EuA =3°C. Weighted average temperature = $0.4 \times 5 + 0.6 \times 3 = 3.8^{\circ}\text{C}$
	"SSS" Min. 0 rpm Max. 150 rpm Default 25 rpm	Step size In order to achieve lower start and stop noise compressor is made to start at certain speed and then ramp up / ramp down to the desired speed. This is the rate at which compressor must ramp up and ramp down from start and stop speed. Ramp up and ramp down rate to ensure smooth start and stop of compressor and reduce compressor noise during start and stop. The actual rpm is multiplied by 10 to the selected value, hence read actual rpm=value*10.
	"CoF" Min. 10 Hz Max. 200 Hz Default 50 Hz	Off frequency This is required frequency from the controller to give stop signal to the compressor. Any frequency below this is considered as stop frequency.
	"uFL" Min. 10 Hz Max. 200 Hz Default 66 Hz	Minimum Frequency Required input frequency from the controller corresponding to minimum speed of the compressor (Compressor speed in rpm = Frequency in Hz * Multiplication factor)
	"uFH" Min. 10 Hz Max. 200 Hz Default 150 Hz	Maximum frequency Required Input frequency from the controller corresponding to Maximum speed of the compressor (Compressor speed in rpm = Frequency in Hz * Multiplication factor)
	"uLF" Min. 1 Max. 100 Default 30	Multiplication factor Multiplication factor used in the compressor to calculate the required speed based on the received frequency signal (Compressor speed in rpm = Frequency in Hz * Multiplication factor)
	"PPF" Min. 0 Max. 100 Default 50	Proportional Gain(Kp) Proportional gain to be used in the PI controller Proportional gain value to be defined based on the required capacity adaptation speed
	"PIF" Min. 0 Max. 100 Default 3	Integral Gain(Ki) Integral gain to be used in the PI controller, Integral gain value to be defined based on the required capacity adaptation speed.
	"PCI" Min. 0 Max. 999 Default 100	Integral Time constant(Ti) Integral time constant to be used in the PI controller, Integral Time Constant value to be defined based on the required capacity adaptation speed
	"EHd" Default no	Sensor Error handling Type Method to handle the refrigeration system in case of cabinet sensor error. "no": no sensor error handling. "SEt": Run the refrigeration system based on error run/stop time.

"EoF" Min. 0 Hz Max. 200 Hz Default 100 Hz	Frequency during Sensor error Frequency at which compressor must run during cab air sensor error. In case of cab air sensor error controller will send this frequency to compressor drive during Error run time "Ert". and during error stop time it will send the Off frequency "CoF"
"Ert" Min. 0 min Max. 60 min Default 5 min	Error Run Time This parameter only become active in the unlikely event of cabinet air sensor error. Ert define the duration the refrigeration system will run during cab air sensor error. Example: "Ert=4" [min] and "ESt=16" [min] will provide an average cooling system activity of 20%. Ert and "ESt" values must be configured based on OEM experience
"ESt" Min. 0 min Max. 60 min Default 5 min	Error Stop Time This parameter only become active in the unlikely event of cabinet air sensor error. ESt define the duration the refrigeration system will stop during cab air sensor error
"CSt" Min. 0 min Max. 30 min Default 2 min	Minimum Stop Time It determines the minimum number of minutes the compressor must remain idle before a Temperature cut-in can take effect. For example, if the temperature sensor indicates that the cut-in temperature has been reached, but the number of minutes set in this parameter have not elapsed since the compressor last stopped, then the compressor will stay OFF. It will only start once the duration given by "CSt" has been reached provided the temperature is still high enough. "CSt" thus overrides the cut-in.
"Crt" Min. 0 min Max. 30 min Default 0 min	Minimum Run Time It determines the minimum number of minutes the compressor must run before a Temperature cut-out can take effect. For example, if the temperature sensor indicated that the cut-out temperature has been reached, but the number of minutes set in this parameter have not elapsed since the compressor last started, then the compressor will continue. It will only stop once the duration given by "Crt" has been reached – provided the temperature is still low enough. "Crt" thus overrides the cut-out.
"uSt" Min. 0 sec Max. 30 sec Default 1 sec	Minimum On time at Start Speed Minimum time the compressor must run at start speed
"Cdd" Min. 0 min Max. 15 min Default 15 min	Compressor Door Open Delay/Cdd This parameter sets the delay in minutes before the compressor stop frequency signal when the door is opened. If set to 15, the function is disabled.
"Srt" Min. 0 min Max. 60 min Default 0 min	System resume after door open Fan and Compressor resume after cut out by door open.
Con	Condenser Protection settings
	NOTE: A condensor temperature sensor is required to use these parameters. Condenser protection is generally used in dusty environments where the condenser may accumulate a layer of dust or dirt and therefore be at risk of overheating.
"CAL" Min. 0°C Max. 200°C Default 80°C	Condenser Alarm Limit/CAL This parameter sets the temperature for the condenser at which an alarm will be generated.
"CbL" Min. 0°C Max. 200°C Default 85°C	Condenser Block Limit/CbL This parameter sets the temperature which if reached will cause the compressor to switch OFF.
"CoL" Min. 0°C Max. 200°C Default 60°C	Condenser OK Limit/CoL This parameter sets the temperature at which the compressor is allowed to start again after the temperature set in "CbL" above has been exceeded and the compressor stopped.

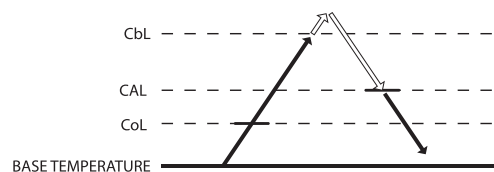

"CLL" Min. -100°C Max. 20°C Default -5°C	Condenser Low Limit/CLL This parameter sets the lowest (condenser) temperature at which the compressor is allowed to start.
diS	Display settings
	NOTE: some display parameters can be set in such a way that they may be illegal in some jurisdictions. Please check local legislation.
"diC" Min. no Max. yes Default no	Display intensity auto control "no": display intensity use fixed value.
"din" Min. 2 Max. 10 Default 10	Display Intensity The controller can have its display intensity (brightness) set in one of two ways: A) With a Danfoss ambient light sensor attached, the brightness of the display is adjusted automatically according to the ambient light level (see the assignments section). B) When no ambient light sensor is attached, the display intensity can be set to a fixed intensity. Both options are on a scale of 1 to 10, where 10 is the brightest.
"CFu" Min. °C Max. °F Default °C	Display Unit This parameter sets the display to Fahrenheit or Celsius. Switching from one to the other will cause all temperature settings to be automatically updated accordingly.
"trS" Default SCo	Temp sensor to display "SCo": temperature control. "EuA": evaporator temperature. "Con": condenser temperature (condenser cleaning). "AtP" Weighted average temperature of "SCo" and "EuA" "AuS": only for showing on display.
"rES" Min. 0.1 Max. 1 Default 0.1	Display Resolution This parameter can be set to 0.1, 0.5 or 1 and affects the way the temperature is displayed. With the parameter set to 1, the display will only ever show temperatures rounded to the nearest whole degree. At 0.5, it will round the temperature to the nearest half degree for display. For example, 3.3 degrees will be shown in the display as 3.5 degrees and 3.9 as 4.0. With the parameter set to 0.1, no rounding occurs. This parameter does not affect the temperature itself, merely the display.
"rLt" Min. no Max. yes Default no	Display Range Limit In some point of sales applications you may want to show the desired instead of the real temperature. This parameter sets whether the displayed temperature is the actual temperature or whether it is restricted to the cut-in / cut-out limits. Set to "no" means that the actual temperature will be displayed. The parameter is set to "no" by default.
"ddl" Min. 0 min. Max. 10 min Default 0 min	Display Delay In order to provide a realistic temperature appearance for an application, a display delay can be set. The parameter sets the time constant τ (tau) of the moving average filter for the display. Physically, one time constant represents the time it takes the system's step-response to reach 66% of its final value and five time-constants the time it takes to reach 99% of its final value.

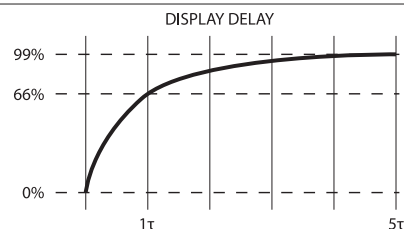

	"doF" Min. -10.0 K Max. 10.0 K Default 0.0 K	Display Offset This parameter is a relative value and allows the temperature displayed to be different to the temperature measured. For instance, at a measured temperature of 7°C and "doF" set to -2K, the displayed temperature will be 5°C instead.
	"dLt" Min. 0 min Max. 60 min Default 15 min	Lock Time After Defrost In order not to show a rising temperature during defrosting, the displayed temperature is locked at the temperature shown at the start of the defrost cycle for the number of minutes set in this parameter. "0": no lock.
	"SEC" Min. no Max. yes Default no	Show Economy State If set to "yES", this parameter causes the display to show ECO when the system is in ECO mode. If set to "nO", the temperature continues to be displayed.
	"SSC" Min. no Max. yes Default no	Show Pull down state If set to "yES", this parameter causes the display to show SC when the system is in pull down mode. If set to "nO", the temperature continues to be displayed.
	"SHo" Min. no Max. yes Default no	Show Holiday "no": display will show temperature or ECO mode during holiday mode. "yES": display will show "HoL" during holiday mode.
	"SdF" Min. no Max. yes Default yes	Show Defrost If set to "yES", this parameter causes the display to show DEF when the system is in defrost mode. If set to "nO", the temperature continues to be displayed.
	"SCS" Min. no Max. yes Default yes	Show compressor symbol "no": compressor symbol will not show on display. "yES": show compressor symbol on display.
	"SFS" Min. no Max. yes Default yes	Show Fan symbol "no": fan symbol will not show on display. "yES": show fan symbol on display.
	"SdS" Min. no Max. yes Default yes	Show Defrost symbol "no": defrost symbol will not show on display. "yES": show defrost symbol on display.
	"SES" Min. no Max. yes Default yes	Show ECO symbol "no": ECO symbol will not show on display. "yES": show ECO symbol on display.
ALA		Alarm settings
	"HAt" Min. -100.0°C Max. 200°C Default 15.0°C	High Temp Alarm Absolute value. By setting "HAt" to the maximum alarms will be deactivated.
	"LAt" Min. -100.0°C Max. 200°C Default -50.0°C	Low Temp Alarm Absolute value. By setting "LAt" to the minimum value, alarms will be deactivated. In most situations, the low alarm delay will be set to 0 to warn about too low a temperature immediately.
	"Htd" Min. 0 min Max. 240 min Default 30 min	Alarm delay on high temperature alarm The number of minutes to wait before sounding an alarm once the high temperature alarm temperature is reached.

<p>"Ltd"</p> <p>Min. 0 min Max. 240 min Default 0 min</p>	<p>Alarm delay on low temperature alarm</p> <p>The number of minutes to wait before sounding an alarm once the low temperature alarm temperature is reached.</p>
<p>"Pdd"</p> <p>Min. 0 min Max. 960 min Default 240 min</p>	<p>Pull down delay</p> <p>Normally, it is not necessary or desirable to sound an alarm during a pull down (the initial phase of reaching the desired temperature). This parameter prevents the high temperature alarm "HAt" sounding during pull down and after a defrost for the number of minutes set for the parameter.</p> <p>NOTE: it does not apply to the low temperature alarm "LA^t".</p>
<p>"dod"</p> <p>Min. 0 min Max. 60 min Default 2 min</p>	<p>Door Open delay</p> <p>It is possible to indicate to customers that a door has accidentally been left open. This parameter sets the delay in minutes before the alarm sounds. This is useful in environments where customers/users may hold the door open while making their selection. If the door is closed again before the set number of minutes is reached, the alarm does not sound.</p> <p>NOTE: a door sensor is required if this parameter is to be activated.</p>
<p>"LEA"</p> <p>Min. 0 hour Max. 96 hour Default 0 hour</p>	<p>Leakage alarm</p> <p>Leakage detection for compressor protection. If compressor operates for more than the set time, an alarm will be triggered.</p> <p>"0": disable</p>
<p>"Abd"</p> <p>Min. 0 min Max. 999 min Default 0 min</p>	<p>Alarm Buzzer Duration</p> <p>The alarm sounds for 10 seconds, followed by silence for 50 seconds. One alarm sequence therefore lasts 60 seconds. These values cannot be changed. This parameter determines how long in minutes an audible alarm will continue while there is still a reason to have an alarm.</p> <p>If set to 999, the alarm will continue to sound until the reason for the alarm is cleared – for example the temperature has dropped enough or the door closed. In some cases, it may be necessary for a user or technician to take action in order to clear the alarm. If set to 0, the alarm will never sound.</p>
<p>"ACA"</p> <p>Min. no Max. yes Default yes</p>	<p>Auto Clear of Alarm/Error/ACA</p> <p>If this parameter is set to "no": The alarm status will not disappear automatically even if the condition which caused the alarm is no longer valid or present.</p> <p>If set to "yES": As soon as the condition which caused the alarm is no longer valid or present, the alarm status will automatically change back to inactive. There will be no trace of the alarm having occurred.</p> <p>In general, glass door merchandise applications will be set to "yES" and commercial fridges and freezers set to "no".</p> <p>For example, if the temperature goes too high for a period there may be food safety considerations in a freezer containing food but not in a fridge with cold drinks.</p> <div data-bbox="981 1299 1468 1467" style="text-align: right;"> <p>SCENARIO (EXAMPLE)</p> <p>TIME →</p> <p>CONTROL STATUS: NORMAL 5,3°C DEVIATION ABOVE 15°C OR BELOW 1°C NORMAL 5,3°C</p> <p>ALARM OUTPUT: [Pulsed bars during deviation]</p> <p>Htd/Ltd IN MINUTES (under deviation)</p> <p>ERROR RECOVERY (under return to normal)</p> </div>
<p>AHC</p>	<p>Automatic Heater settings</p>
	<p>Automatic Heater Control applies reverse cooling mode (heating) to your refrigeration appliance.</p> <p>This feature requires:</p> <p>A) that your appliance is exposed to ambient temperatures below the desired temperature in your cabinet (e.g. very cold climates and outdoor use).</p> <p>B) a special heater (for example a large defrost heater) built in to your appliance.</p> <div data-bbox="981 1635 1468 1803" style="text-align: right;"> <p>COOLER CUT-IN</p> <p>HEATER CUT-OUT</p> <p>COOLER CUT-OUT</p> <p>HEATER CUT-IN</p> </div>
<p>"AuH"</p> <p>Min. no Max. yes Default no</p>	<p>Automatic Heater Mode Enable</p> <p>This setting is normally set to "no".</p> <p>When set to "yES", parameters "End" and "Hdi" apply.</p>

	"End" Min. 0 min Max. 360 min Default 60 min	Energy Mode Delay This is the delay in minutes between the heater and the compressor operation. The heater is not allowed to start until this number of minutes has expired after the compressor has cut out and vice versa.
	"AHS" Min. -100.0°C Max. 200.0°C Default 2.0°C	Auto Heat set point Set point of auto heating.
	"AHD" Min. 0.0 K Max. 20.0 K Default 2.0 K	Auto heat differential Thermostat differential for auto heating.
ECS		ECO strategy
		NOTE: some of these parameters require the installation of the Danfoss Ambient Light Sensor. The Danfoss USB Gateway in combination with "KoolProg Software" allows for real time measurement of the current light intensity. Danfoss recommends testing and adjusting "SLd" and "SLn" values according to customers' specific needs.
	"ECO" Min. no Max. yes Default Yes	ECO ON/OFF ECO active or not. If no all other settings are not active.
	"EdA" Min. 1 Max. 10 Default 1	Door Actions Times of door action to trigger exiting ECO
	"EPA" Min. 1 Max. 10 Default 1	Pir Actions Times of "PIR" action to trigger exiting ECO
	"ECt" Min. 0 min Max. 180 min Default 30 min	Action counter time It is the duration of time for which the controller will check for number of times of Door action or activity through PIR sensor (mentioned in "EDA" and "EPA" parameters) to exit the ECO mode.
	"Edd" Min. 0 min Max. 180 min Default 180 min	Door delay Door delay after door close to trigger entering ECO
	"EPd" Min. 0 min Max. 180 min Default 120 min	Pir delay "PIR" delay to trigger entering ECO
	"SLd" Min. 0 Max. 80 Default 5	Shop Light Day/SLd Shop Light Night/SLn These parameters are set as the percentage of the maximum light and determine when the device moves into or out of ECO mode for power-saving purposes. Requires Light Sensor.
	"SLn" Min. 0 Max. 80 Default 3	"SLd" is the amount of ambient light which will cause the device to move to normal/serving mode from ECO mode (normally occurs in the morning). "SLn" is the amount of ambient light which will cause the device to move to ECO mode from normal/serving mode (normally occurs in the evening).
	"tto" Min. 0 hour Max. 168 hour Default 0 hour	Time to pull down Time that ERC must stay in ECO to go into Pulldown upon exiting ECO. E.g: If tto = 2, if the ERC stays in ECO for 2 or more hours, it will go into Pulldown after exiting ECO. If it stays in ECO for less than 2 hours, it will go to Serving Mode upon exiting ECO.
	"LSd" Min. 0 min Max. 180 min Default 0 min	Light Source delay on ECO Time delay for light source to change from serving mode source to ECO mode source.

	"Euu" Min. no Max. yes Default yes	EWU active on/OFF Enable or disable early wake up.
	"CLH" Min. 0 hour Max. 24 hour Default 6 hour	Shop close hour Shop is assumed to be closed when staying in ECO mode longer than shop close hour.
	"Erl" Min. 0 min Max. 240 min Default 120 min	Early wake up time offset Time of exiting ECO mode for next day= Time of first activity to exit ECO mode - the early wake-up time. "0": early wake up function disabled."
	"Hol" Min. 0 hour Max. 999 hour Default 72 hour	Holiday Length If controller stays for longer than HoL in ECO and no activity is detected, the controller will go into Holiday Mode. Early Wake Up is disabled.
ECA		ECO management
	"Eto" Min. -25,0 K Max. 25,0 K Default 4.0 K	Eco Temperature Offset This parameter gives a relative temperature in degrees. It is the difference in temperature for ECO mode operation compared to normal mode. NOTE: setting a temperature offset may be illegal in some jurisdictions.
	"Hto" Min. -25,0 K Max. 25,0 K Default 6,0 K	Holiday Temperature Offset Increase or decrease of temperature with respect to normal mode during holiday mode.
	"diE" Min. 0,0 K Max. 10,0 K Default 2,0 K	ECO Differential Thermostat differential for ECO.
	"FoE" Min. 0 s Max. 960 s Default 0 s	ECO Fan on cycle On time for fan during compressor OFF period in ECO mode.
	"FSE" Min. 0 s Max. 960 s Default 0 s	ECO Fan stop cycle OFF time for fan during compressor OFF period in ECO mode.
	"ELC" Default on	ECO Cabinet light control "on": always ON (Button is default to control light for all these options). "oFF": always OFF. "dor": door sensor only.
	"ELd" Min. 0 min Max. 10 min Default 5 min	Eco Light Delay This parameter causes a delay to the switch from normal to ECO mode when the shop lights are switched ON or OFF. The ambient light sensor detects the change in light level and causes a switch mode. With this parameter set to zero, the switch OFF mode occurs immediately. If not set to zero (max: 10 minutes), then the change will be delayed by the number of minutes set.
ASi		Assignments settings
	"uSA" Min. no Max. yes Default no	MODBUS Safety "no": MODBUS auto detection is enable and serial communication is available for configuration software tool. "yES": MODBUS communication is deactivated.

<p>"t1A" Min. -20.0 K Max. 20.0 K Default 0.0 K</p>		<p>Air Temperature Adjustment (applies to non-Danfoss temperature sensors only) This parameter is a relative value and allows adjustment of the control sensor temperature.</p>
<p>"t2A"</p>		<p>For instance, at a measured temperature of 7°C and "tAd" set to -2 K, the input from the control sensor will be 5°C instead.</p>
<p>"t3A"</p>		
		<p>Inputs and outputs are configurable There are two steps: 1. Define the type of sensor attached to the input: - temperature: light/digital. 2. Define the application for the sensor: - temperature: control/condenser/evaporator. - light: ECO/display/both. - motion - digital: door sensor. Please contact your local Danfoss representative for information about default settings. NOTE: coded sensors will impact on the number of possible configurations. For instance: Danfoss supplies only 2-pole defrost sensors, so input "S3" will most likely be used as a defrost/evaporator temperature sensor input.</p>
<p>"S1C" Default Stn</p>		<p>S1 Config/S1C S2 Config/S2C S3 Config/S3C</p>
<p>"S2C" Default Stn</p>		<p>Available options are: "Stn": for a standard temperature sensor NTC 5 K @ 25°C and TPE precision. "Htn": for a high temperature sensor NTC 100 K @ 25°C.</p>
<p>"S3C" Default Stn</p>		<p>"Ldr": for a light sensor (values given in Luminens). "dig": for a digital sensor with simple ON/OFF indication (motion, magnet, switch, button).</p>
<p>"S1A" Default SCo</p>		<p>S1 Application/S1A S2 Application/S2A S3 Application/S3A Available options are:</p>
<p>"S2A" Default nC</p>		<p>"nC": not connected. "SCo": temperature control. "EuA": evaporator temperature. "Con": condenser temperature (Condenser cleaning).</p>
<p>"S3A" Default nC</p>		<p>"AuS": only for showing temperature on display. "Ldr": light sensor, Luminens. "ECo": external input to control ECO mode. "doC": door contact, contact closed when door closed. "doo": door contact, contact open when door closed. "Pir": motion sensor (only "S3").</p>
<p>"diC" Default non</p>		<p>DI Config This is the digital input used for a digital sensor or bus communications. "non": not used. "doC": door contact, contact closed when door closed. "doo": door contact, contact open when door closed. "ECo": external input to control ECO mode. "Pir": motion sensor. Passive infrared.</p>
<p>"o1C" Default Con</p>		<p>D01 Config Condenser relay will follow the compressor ON/OFF, it will be turned On whenever compressor is ON and turned off when compressor is OFF. "Con": condenser fan control "PiC": pilot Relay (no zero cross) – if using pilot relay to control a condenser, this option must be used instead of "Con".</p>

	"o2C" Default dEF	D02 Config/o2C D03 Config/o3C D04 Config/o4C																															
	"o3C" Default FAn	"no": not used. "dEF": electric defrost heater/valve for hot gas. "ALA": alarm output.																															
	"o4C" Default Lig	"FAn": fan control. "Lig": light control.																															
	"b1C" Default noP	Lower left button: Button 1 Config (short press)/b1C Button 1 Config (long press)/b1L	<p>The buttons can be programmed as follows:</p> <table border="1"> <thead> <tr> <th>Short press function</th> <th>Long press function (3 s.)</th> </tr> </thead> <tbody> <tr> <td>"noP": not operating</td> <td>"noP": not operating</td> </tr> <tr> <td>"tP": increase set point</td> <td>"tP": increase set point</td> </tr> <tr> <td>"tn": decrease set point</td> <td>"tn": decrease set point</td> </tr> <tr> <td>"ECo": toggle Eco mode</td> <td>"ECo": toggle Eco mode</td> </tr> <tr> <td>"Lig": toggle light</td> <td>"Lig": toggle light</td> </tr> <tr> <td>"dEF": toggle defrost</td> <td>"dEF": toggle defrost</td> </tr> <tr> <td>"SuP": toggle super-cool/pull down</td> <td>"SuP": toggle super-cool/pull down</td> </tr> <tr> <td>"diP": increase display intensity</td> <td>"diP": increase display intensity</td> </tr> <tr> <td>"din": decrease display intensity</td> <td>"din": decrease display intensity</td> </tr> <tr> <td>"CFA": toggle °C and °F</td> <td>"CFA": toggle °C and °F</td> </tr> <tr> <td></td> <td>"PoF": ERC power ON/OFF</td> </tr> <tr> <td></td> <td>"HoL": enter holiday mode</td> </tr> <tr> <td></td> <td>"inF": enter info menu</td> </tr> <tr> <td></td> <td>"tEC": Toggle Winter & Summer Eco mode</td> </tr> </tbody> </table> <p>NOTE: Your assignments may not be shown on the printed buttons. We advice to use this functionality together with the fully integrated mounting model only.</p>	Short press function	Long press function (3 s.)	"noP": not operating	"noP": not operating	"tP": increase set point	"tP": increase set point	"tn": decrease set point	"tn": decrease set point	"ECo": toggle Eco mode	"ECo": toggle Eco mode	"Lig": toggle light	"Lig": toggle light	"dEF": toggle defrost	"dEF": toggle defrost	"SuP": toggle super-cool/pull down	"SuP": toggle super-cool/pull down	"diP": increase display intensity	"diP": increase display intensity	"din": decrease display intensity	"din": decrease display intensity	"CFA": toggle °C and °F	"CFA": toggle °C and °F		"PoF": ERC power ON/OFF		"HoL": enter holiday mode		"inF": enter info menu		"tEC": Toggle Winter & Summer Eco mode
Short press function	Long press function (3 s.)																																
"noP": not operating	"noP": not operating																																
"tP": increase set point	"tP": increase set point																																
"tn": decrease set point	"tn": decrease set point																																
"ECo": toggle Eco mode	"ECo": toggle Eco mode																																
"Lig": toggle light	"Lig": toggle light																																
"dEF": toggle defrost	"dEF": toggle defrost																																
"SuP": toggle super-cool/pull down	"SuP": toggle super-cool/pull down																																
"diP": increase display intensity	"diP": increase display intensity																																
"din": decrease display intensity	"din": decrease display intensity																																
"CFA": toggle °C and °F	"CFA": toggle °C and °F																																
	"PoF": ERC power ON/OFF																																
	"HoL": enter holiday mode																																
	"inF": enter info menu																																
	"tEC": Toggle Winter & Summer Eco mode																																
	"b1L" Default PoF	Upper left button: Button 2 Config (short press)/b2C Button 2 Config (long press)/b2L																															
	"b2C" Default dEF	Upper right button:																															
	"b2L" Default inF	Button 3 Config (short press)/b3C Button 3 Config (long press)/b3L																															
	"b3C" Default tP	Lower right button: Button 4 Config (short press)/b4C Button 4 Config (long press)/b4L																															
	"b3L" Default ECo																																
	"b4C" Default tn																																
	"b4L" Default Lig																																
	"PS1" Min. 0 Max. 999 Default 0	Password level 1 / PS1 Password Level 2 / PS2 Password Level 3 / PS3 These assign passwords to the three levels of access. The password is a three-digit number. Access levels are Shop, Service and OEM. You may not therefore have access to change all the passwords. Passwords are entered by using the up and down arrow buttons. Danfoss advises against using passwords which are easy to remember or enter, for example 111, 222, 123 etc.																															
	"PS2" Min. 0 Max. 999 Default 0																																
	"PS3" Min. 0 Max. 999 Default 0	NOTE: When accessing the controller with 3 wrong password in a sequence ERC will automatically block access for 15 minutes.																															
Ser	Service information settings																																
	The parameters in the following section are READ ONLY and cannot be changed by the user. They provide information for technicians and OEM users. NOTE: the only parameters that can be configured are: "oEL", "oEn", "oEH". These parameters allow OEMs to enter their own product code.																																
	"ACt"	Accumulated Comp. run time																															
	"AFt"	Accumulated Fan run time																															
	"ALt"	Accumulated Light run time																															
	"AEt"	Accumulated ERC up time																															

"Sdi"	DI physical DI pin state (ON; OFF).
"uAC"	Voltage value Current main power supply voltage.
"ouS"	DOs Status Current relay open closed status. "////" = all relay ON (Upper bar for on, Lower bar for OFF). " " = DO1 ON, DO2 OFF, DO3 & DO4 NA (no bar if relay not mounted). "////" = all relay OFF (Upper bar for on, Lower bar for OFF).
"rL1"	Relay 1 counter Thousands of cycles of no. 1 relay since manufacture.
"rL2"	Relay 2 counter Thousands of cycles of no. 2 relay since manufacture.
"rL3"	Relay 3 counter Thousands of cycles of no. 3 relay since manufacture.
"rL4"	Relay 4 counter Thousands of cycles of no. 4 relay since manufacture.
"int"	Interval Counter Elapsed / Compressor run time since last defrost
"dnt"	Defrost time counter Duration of last defrost cycle [min].
"ont"	Door open counter "ont/100"=number of door openings since last reset.
"Snu"	Serial number Serial number given at manufacturing.
"Fir"	SW version Danfoss software version number.
"HAr"	HW version Danfoss hardware version number.
"onL"	OrderNoLow Danfoss order code number.
"onH"	OrderNoHigh Danfoss order code number.
"oEL"	OEM code Low
"oEn"	OEM code Middle
"oEH"	OEM code High
"PAr"	Parameter version OEM parameter version number [requires EKA copy key update].
"CHd"	Manufacturing date Programme date WWY: week number and year number (2010-19).
"SFC"	Set as Default Resets all parameters to last good OEM settings.
"Ctt"	Condenser Temp Temperature of the condensor sensor.
"Et1"	Evaporator1 Temp Temperature of the evaporator sensor1.
"Et2"	Evaporator2 Temp Temperature of the evaporator sensor2.

"Fot"	Frequency Output Actual output frequency of the controller
"AtP"	Weighted Average Temperature Weighted average temperature of cabinet air and evaporator sensors
"AuS"	AUX Temp. Temperature of the AUX sensor. invisible.
"LLu"	Light level value Actual light level value from light sensor.
"Pir"	Motion sensor state
"att"	Cabinet air temp
"ESS"	External ECO switch state
	Display messages
"unP"	Device is unprogrammed (relay output is locked)
"Prg"	Device has not finished programming (relay output is locked)
"Eco"	Device is in Eco mode
"SC"	Device is in pull-down mode (super-chill)
"dEF"	Device is defrosting
"HoL"	Device is in Holiday mode

Troubleshooting

Problem	Probable cause	Remedy
Compressor does not start	Faulty frequency table Wrong / loose connection of frequency cable	Check the frequency cable continuity. Check the connection of frequency cable at controller and drive side
Fan does not start	Door is open or door contact is defective	Fan stops when door is opened Check that door contact is ok
Defrost does not start	Controller in pull down mode	Defrost might be delayed during pull down Check parameter Pud->Pdi
Alarm does not sound	Alarm delayed	Check ALA->Htd, Abd Check Pud->Pdd
Display brightness is weak	Ambient light sensor broken	Replace sensor
Shift between ECO and normal mode does not happen on ambient light change	Ambient light sensor broken or light level not set properly	Check Eng->SLd, SLn
Display alternates between condenser and temperature	Condenser too hot	Clean condenser Check Con ->CAL, CbL
Display alternates between high and temperature	Temperature too high	Check ALA->HAt
Display alternates between low and temperature	Temperature too low	Check ALA -> LAT
Display shows "dEP"	Defrost in progress	Check diS ->SdF

Alarm code	Trigger	Automatic clearance	Outputs	Comments
"Hi"	Air temperature is higher than "ALA->Hat" for "ALA->Htd"	User configured	Blink "Hi" with the highest temperature; If configured: cut in alarm relay, beep the buzzer	High temperature alarm
"Lo"	Air temperature is lower than "LAT" for "Ltd"	User configured	Blink "Lo" with the lowest temperature. If configured: cut in alarm relay, beep the buzzer	Low temperature alarm
"Con"	Condenser temperature is too high or too low	User configured	Blink "Con". If configured: cut in alarm relay, beep the buzzer	Condenser alarm
"dor"	Door open for more than "ALA->dod"	Always	Blink "dor". If configured: cut in alarm relay, beep the buzzer	Door open alarm
"uHi"	Line voltage is higher than "Cop->uHi"	Always	Blink "uHi". If configured: cut in alarm relay, beep the buzzer	High voltage alarm
"uLi"	Line voltage is lower than "Cop->uLi"	Always	Blink "uLo". If configured: cut in alarm relay, beep the buzzer.	Low voltage alarm
"LEA"	Compressor continuous running for more than "ALA->LEA"	Always	Blink "LEA". If configured: cut in alarm relay, beep the buzzer	Leakage alarm
"E01"	"S1" error	Always	Blink "E01". If configured: cut in alarm relay, beep the buzzer	"S1" sensor failure (short or open)
"E02"	"S2" error	Always	Blink "E02". If configured: cut in alarm relay, beep the buzzer	"S2" sensor failure (short or open)
"E03"	"S3" error	Always	Blink "E03". If configured: cut in alarm relay, beep the buzzer	"S3" sensor failure (short or open)

Sensor placement

Control sensor

The control sensor must always be connected and is used for controlling the cut-in and cut-out of the compressor according to the set point. The sensor is also used for the displayed temperature.

Control sensor

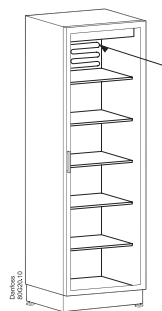

Vertical coolers with fan

Most common placement is in the return air to the evaporator. The sensor can be placed close to the fan – even when the fan is pulsed during compressor OFF periods: the updating of the temperature is blocked when the fan is stopped and only updated when the fan has been running for a while, so that the heat from the fan does not affect the temperature reading.

For applications sensitive to sub-zero temperatures, sensor placement in the evaporator outlet air can be considered.

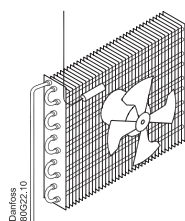

Vertical freezers with fan

Placement in the return air or in the freezer compartment.

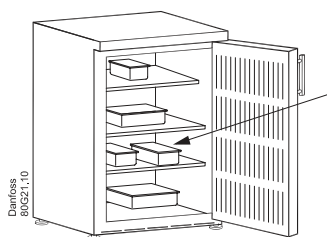

Coolers without fan

The best results are normally obtained when the sensor is placed at the side-wall, 10 cm from the back and approximately at 1/3 from the bottom or where the evaporator ends.

The control sensor must always be connected and is used for controlling the cut-in and cut-out of the compressor according to the set point. The sensor is also used for the displayed temperature.

Evaporator sensor

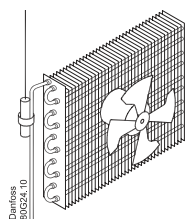

The evaporator sensor is only used for de-icing of the evaporator and has no control purpose.

Placement of sensor

Place the sensor where the ice melts last. Please be aware of that sharp fins can damage the cable.

Condenser sensor

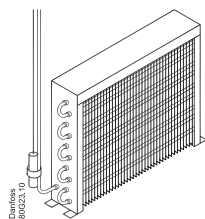

The condenser sensor is used to protect the compressor against high pressure when the condenser is blocked or the condenser fan fails.

Condenser sensor

Place the sensor at the liquid side of the condenser. Use a metal bracket or metal tape to ensure good thermal conductivity. Be sure that the cable does not pass hot spots at the compressor or condenser that exceeds 80°C.

Ambient light sensor

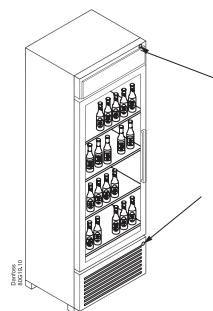

The ambient light sensor is used to detect opening hours of the shop.

Placement of sensor

The sensor must be placed so that the interior light does not affect the sensor. Possible placement could be in the front of the cooler or at the top.

Door sensor

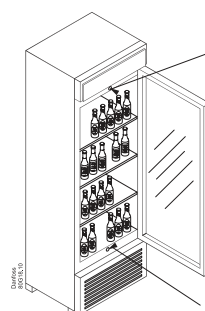

The door sensor is used to detect buying activity and to stop the fan when the door is opened.

Door sensor

Danfoss does not supply the door-switch. Use the door-switch you have and connect it to the cable supplied by Danfoss.

Typical applications

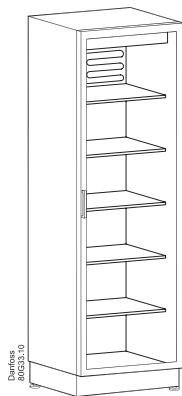

Glass Door Merchandiser,
No-frost freezer/sub-zero cooler

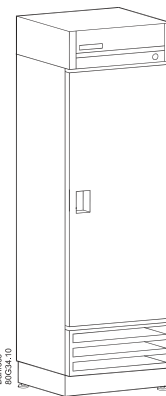

Gastro No-frost freezer

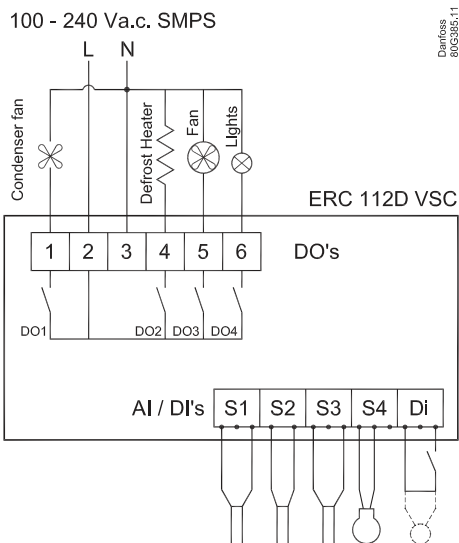

Danfoss
80G3393-11

Note: this is a typical (default) wiring diagram since both inputs (AI/DI's) and outputs (DO's) can be assigned differently. Please see "ASI", assignment

ERC 112D VSC	
Blue LED with buzzer	080G3414

Temperature Sensor for Cabinet Temperature Control	Temperature Sensor for Evaporator Temperature Control	Temperature Sensor for Condenser Temperature Control	VS Compressor drive output	Motion detection also connectable to S3	Door input	
PVC Standard Connector type (S1) 3-pole	PVC Standard Connector type (S2) 2-pole	PVC Standard Connector type (S3) 3-pole	Cable Connector type (Di) 3-pole	Motion sensor Connector type (Di) 3-pole	Door sensor cable (Di) 3-pole	Magnetic door sensor (Di) 3-pole
470 mm 077F8751	1000 mm 077F8786	1000 mm 077F8756	3500 mm 080G3397	1000 mm 080G3390	1000 mm 080G3340	1000 mm 080G3320
1000 mm 077F8757	1500 mm 077F8790	1500 mm 077F8760		2000 mm 080G3391	2000 mm 080G3341	2000 mm 080G3322
1500 mm 077F8761	2000 mm 077F8794	2200 mm 077F8766		3000 mm 080G3392	3000 mm 080G3342	3000 mm 080G3324
2000 mm 077F8765	3000 mm 077F8798	3000 mm 077F8768		4000 mm 080G3393	4000 mm 080G3343	
2200 mm 077F8767	6000 mm 080G2029	6000 mm 080G2039				
3000 mm 077F8769						
3500 mm 077F8723						
6000 mm 080G2019						

ENGINEERING
TOMORROW

Danfoss