

ENGINEERING
TOMORROW

Danfoss

Installation Guide • Installationshandbuch • Manuel d'installation • Guida di installazione • 安装
指南 • Guía de instalación • Guia de Instalação

iC7-Automation Frequency Converters Quick Installation Guide

FA02-FA08/FK06-FK08 (1.3-170 A)





Scan to access more
documentation

1 Instructions

1.1 Safety and Installation Awareness

A quick installation guide and a safety guide are provided with the drive. Before starting installation, read all safety guidelines and precautions in the safety guide (136R0243). For details on cyber security, see Security Features in the application guide (136R0283). Additional resources - including a design guide, an application guide, and a comprehensive installation guide - can be downloaded at www.danfoss.com/service-and-support.

1.2 Required Tools

- Lifting aid
- Tape measurer
- Wrench with extension and 10 mm socket
- Torx and slotted screwdrivers (T15, T20, T25, T30, T50, SL1, and SL2)
- Wire crimper
- Sheet metal punch and/or pliers for cable entry plate

1.3 Verifying the Shipment and the Contents

Make sure that the items supplied and the information on the product label correspond to the order confirmation. The product label is found on the top of the drive.

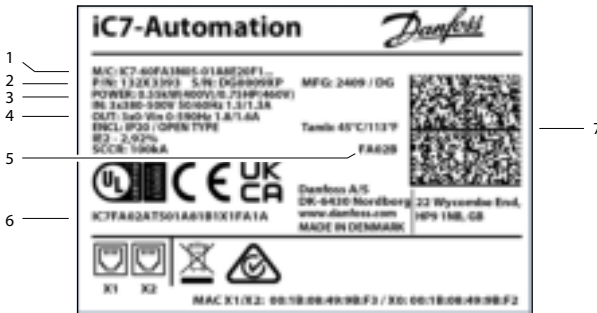

Illustration 1: Example of a Product Label

1	Model code (2D code shows the full model code)	5	2D code – accessible by using a Datamatrix ECC 200 compatible barcode reader – containing the model code, serial number, and manufacture date
2	Code number, serial number, manufacture date (YYWW)		
3	Power rating	6	Frame designation
4	Input and output voltage, frequency, and current	7	Compliance code

1.4 EMC-compliant Installation

For EMC-compliant installation, refer to the operating or design guide and follow the electrical installation instructions.

Use shielded cables for motor output (unshielded cables within metal conduit are also acceptable), brake, DC, and control wiring.

Connect the shield to the enclosures at both ends. If the shield connection points have a voltage potential difference, connect a low impedance equalizing wire parallel to the shielded cable. Otherwise, break the shield connection on one end to prevent ground current loops.

Ensure that motor, brake, and DC cables are as short as possible to reduce the interference level from the entire system.

Provide a minimum 200 mm (7.9 in) separation, if possible, between mains input, motor cables, and control cables.

- Convey the currents back to the unit using an EMC plate. Ensure good electrical contact from the EMC plate through the mounting screws to the drive chassis.
- Parts identified with (!) must be installed. See step 4 in the Illustrations section.

1.5 Installing the Drive

⚠ WARNING ⚠

SHOCK HAZARD

Touching an uncovered motor, mains, or DC connection plug or terminal can result in death or serious injury.

- All plugs and terminal protection covers for the motor, mains, and DC connections must be installed within the IP20 enclosure to provide an IP20 protection rating. If the plug and terminal covers are not installed, the protection rating is considered IP00.

The installation location is important.

Full output current is available when the following installation conditions are met. For temperatures and altitudes outside this range, consult the Derating section in the design guide.

- Maximum ambient air temperature: 45 °C (113 °F) average over 24 hours and 50 °C (122 °F) for 1 hour.
- Minimum ambient air temperature: -30 °C (-22 °F).
- Altitude < 1000 m (3280 ft) above sea level.

Procedure

1. Identify the frame designation. See [Illustration 1](#).
2. Verify that the operating environment and electrical installation meet the following standards.
 - a. Indoor unconditioned/pollution degree 2.
 - b. Overvoltage category 3.
3. Review the wiring diagram. See step 1 in the Illustrations section.

All wiring must comply with local and national regulations regarding cross-section and ambient temperature requirements. Loose connections can cause equipment faults or reduced performance. Tighten the terminals according to the proper torque value shown in step 8.

4. Review the fuse specifications. See step 2 in the Illustrations section.

The drive is suitable for use on a circuit capable of delivering up to 100 kA short circuit current rating at the respective drive voltage rating. For circuit breaker/combination motor controller and mains disconnect switch SCCR ratings, see the design guide.

5. Review the power cable specifications. See step 3 in the Illustrations section.

Use copper wire with a minimum 70 °C (158 °F) rating for Fx02–Fx07 enclosures and 90 °C (194 °F) rating for Fx08 enclosures. For aluminum wire, see the design guide.

6. Install the drive following the numbered steps in the Illustrations section. Certain illustrations/steps pertain to specific frame designations and are marked as such. If it applies to all variants, the 2nd character in the frame designation is replaced with an x, for example Fx06, indicating FA06, FB06, and FK06.
 - a. Attach accessory bag components to the drive (step 4).
 - b. Mount the drive on or against a solid, non-combustible mounting surface such as concrete or metal (step 5). Ensure proper cooling by providing minimum clearance above and below the drive.
 - c. For frames FK06–FK08, drill cable openings in the cable entry plate and install the cable glands (step 6).
 - d. Install the control wiring (step 7).
 - e. Install the motor, mains, and PE ground wiring (step 8).
 - f. Route the control cables (step 9)
7. Securely fasten the cover to the drive.
8. Perform initial drive and motor setup. Consult the *iC7 Series Industry Application Guide*.
9. Configure the fieldbus. Consult the *iC7 Series Fieldbus Application Guide*.

1.6 Functional Safety (Safe Torque Off)

The drive is shipped with all safe inputs de-energized. Without extra wiring to the safe I/O terminal blocks (X31 and X32), the STO function is always active and the motor will not turn.

- To disable the STO function, install jumper wires to terminals X31 and X32. See step 7.
- To use the STO function, wire a safety device to 1 or both of the safe I/O terminal blocks. See step 1. To prevent erroneous faults or warnings from occurring, any unused safe I/O terminal blocks must be disabled using jumper wires or a jumper clip. One jumper clip is included in the accessory bag.

For more information, refer to the *iC7 Series Functional Safety Operating Guide* (136R0268).

⚠ WARNING ⚠

RESIDUAL ROTATION

The STO function can be used for asynchronous, synchronous, and permanent magnet motors. Two faults can occur in the power semiconductor of the drive. When using synchronous or permanent magnet motors, a residual rotation can result from the faults. The rotation can be calculated to angle = $360/(\text{number of poles})$. The application using synchronous or permanent magnet motors must consider this residual rotation and ensure that it does not pose a safety risk. The situation is not relevant for asynchronous motors.

NOTICE

A successful commissioning test of the STO function is required after the initial installation and after each subsequent change to the installation or application involving the STO.

Commissioning test

There are 2 types of commissioning tests based on how the STO parameter is configured. For more information on the STO parameter, see the application guide.

- If *Parameter 7.2.1 Safe Torque Off Response = Fault, reset required*, perform the commissioning steps marked with an "M".
- If *Parameter 7.2.1 Safe Torque Off Response = Warning, no reset required*, perform the commissioning steps marked with an "A".

Table 1: Commissioning Test for STO Functionality

Type of test	Commissioning steps	X
M/A	Power on the frequency converter.	<input type="checkbox"/>
M/A	Verify that no safety faults are present.	<input type="checkbox"/>
M/A	Start the motor.	<input type="checkbox"/>
M/A	Without interrupting the mains supply, remove the 24 V DC voltage supply to both STO input terminals using the safety device.	<input type="checkbox"/>
M/A	Verify that the motor coasts. This process can take some time.	<input type="checkbox"/>
M/A	Verify that STO activated is shown on the control panel or in the event log.	<input type="checkbox"/>
M/A	If the STO feedback is utilized, verify that STO is activated by checking the state of the STO Feedback.	<input type="checkbox"/>
M/A	Reapply 24 V DC supply to both the STO input terminals.	<input type="checkbox"/>
M/-	Verify that the motor remains in the coasted state and any connected relays remain activated.	<input type="checkbox"/>
M/-	Send a reset signal via fieldbus, digital I/O, or the control panel.	<input type="checkbox"/>
M/A	Verify that the motor starts up and runs within the original speed range.	<input type="checkbox"/>

1.7 Power Losses and Efficiency

For power loss data including part load losses, see <https://ecosmart.mydrive.danfoss.com>.

1 Handbuch

1.1 Bewusstsein hinsichtlich Sicherheit und Installation

Eine Schnellinstallationsanleitung und ein Sicherheitshandbuch sind im Lieferumfang des Frequenzumrichters enthalten. Lesen Sie vor Beginn der Installation alle Sicherheitsrichtlinien und Schutzmaßnahmen im Sicherheitshandbuch (136R0243). Weitere Informationen zur Cybersicherheit finden Sie unter Sicherheitsfunktionen in der Anwendungsanleitung (136R0283). Weitere Ressourcen – einschließlich eines Projektierungshandbuchs, einer Anwendungsanleitung und einer umfassenden Installationsanleitung – können Sie unter www.danfoss.com/service-and-support herunterladen.

1.2 Erforderliche Werkzeuge

- Hubvorrichtung
- Bandmaß
- Schraubenschlüssel mit Verlängerung und 10-mm-Steckschlüsseleinsatz
- Torx- und Schlitzschraubendreher (T15, T20, T25, T30, T50, SL1 und SL2)
- Kabelcrimper
- Blechstanze und/oder Zange für Kabeleinführungsplatte

1.3 Überprüfung der Sendung und des Inhalts

Stellen Sie sicher, dass die gelieferten Teile und die Angaben auf dem Typenschild mit der Auftragsbestätigung übereinstimmen. Das Typenschild befindet sich oben auf dem Frequenzumrichter.



Abbildung 1: Beispiel für ein Produkttypenschild

1	Typencode	5	2D-Code – mit einem Datamatrix ECC 200-kompatiblen Barcodescanner abrufbar – enthält Typencode, Teilenummer, Seriennummer und Herstellungsdatum
2	Teilenummer, Seriennummer und Herstellungsdatum (JJWW)	6	Baugröße
3	Nennleistung	7	Konformitätscode
4	Ein- und Ausgangsspannung, Frequenz und Strom		

1.4 EMV-gerechte Installation

Informationen zur EMV-gerechten Installation finden Sie im Betriebs- oder Projektierungshandbuch. Halten Sie sich darüber hinaus an die Anweisungen für die elektrische Installation.

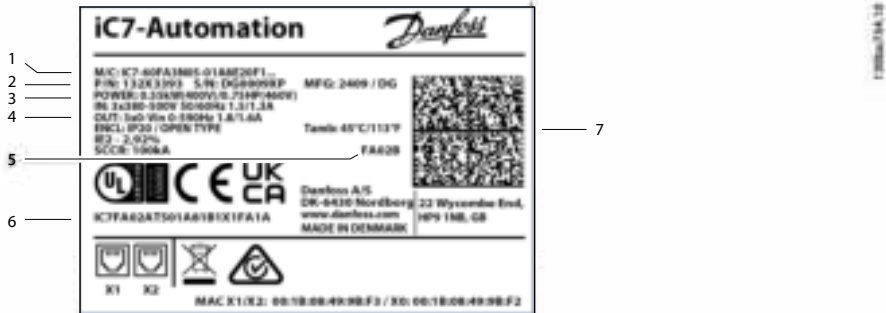
- Verwenden Sie für die Motorausgangs-, Brems-, Gleichstrom- und Steuerkabel abgeschirmte Kabel (ungeschirmte Kabel in Metallrohren sind ebenfalls zulässig).
- Verbinden Sie das Schirmgeflecht an beiden Enden mit den Gehäusen. Schließen Sie einen niederohmigen Ausgleichsdraht parallel zum abgeschirmten Kabel an, wenn die Anschlusspunkte des Schirmgeflechts eine Spannungspotenzialdifferenz aufweisen. Anderenfalls unterbrechen Sie die Schirmgeflechtverbindung an einem Ende, um Erdstromschleifen zu vermeiden.
- Stellen Sie sicher, dass die Motor-, Brems- und Gleichstromkabel so kurz wie möglich gehalten werden, um das Störungslevel des Gesamtsystems zu reduzieren.
- Halten Sie, wenn möglich, zwischen Netzeingang, Motorkabeln und Steuerleitungen einen Mindestabstand von 200 mm ein.
- Führen Sie die Ströme mithilfe eines Abschirmblechs zurück zum Gerät. Durch die Montageschrauben muss stets ein guter elektrischer Kontakt vom Abschirmblech zum Frequenzrichtergehäuse gewährleistet sein.
- Mit (!) gekennzeichnete Teile müssen installiert werden. Siehe Schritt 4 im Abschnitt Abbildungen.

1.5 Installation des Frequenzrichters

⚠ W A R N U N G ⚠

STROMSCHLAGEFAHR

Das Berühren eines nicht abgedeckten Motor-, Netz- oder DC-Anschlusssteckers oder -anschlusses kann zum Tod oder zu schweren Verletzungen führen.

- Alle Stecker und Klemmschutzabdeckungen für die Motor-, Netz- und DC-Anschlüsse müssen innerhalb des IP20-Gehäuses installiert werden, um die Schutzart IP20 zu gewährleisten. Wenn der Stecker und die Klemmenabdeckungen nicht installiert sind, gilt die Schutzart IP00.

Der Einbauort ist wichtig.

Der volle Ausgangsstrom steht zur Verfügung, wenn die folgenden Installationsbedingungen erfüllt sind. Für Temperaturen und Höhen außerhalb dieses Bereichs lesen Sie bitte den Abschnitt zur Leistungsreduzierung im Projektierungshandbuch.

- Maximale Umgebungslufttemperatur: 45 °C im Mittel über 24 Stunden und 50 °C während 1 Stunde.
- Minimale Umgebungslufttemperatur: -30 °C.
- Höhe weniger als 1000 m über Meereshöhe.

Vorgehensweise

1. Ermitteln Sie die Baugröße. Siehe [Abbildung 2](#).
2. Überprüfen Sie, dass die Betriebsumgebung und die elektrische Installation den folgenden Normen entsprechen.
 - a. Innenräume nicht klimatisiert/Verschmutzungsgrad 2.
 - b. Überspannungskategorie 3.
3. Überprüfen Sie den Schaltplan. Siehe Schritt 1 im Abschnitt Abbildungen.

In Bezug auf Querschnitte und Umgebungstemperaturen müssen alle Leitungen lokale und nationale Vorschriften erfüllen. Lockere oder lose Anschlüsse können zu Gerätefehlern oder Leistungseinbußen führen. Ziehen Sie die Klemmen gemäß den unter Schritt 8 angegebenen Drehmomenten fest.

4. Überprüfen Sie die Sicherungsspezifikationen. Siehe Schritt 2 im Abschnitt Abbildungen.

Der Frequenzrichter ist für einen Stromkreis mit einem Kurzschluss-Nennstrom (SCCR) von maximal 100 kA bei der entsprechenden Nennspannung des Frequenzrichters geeignet. Die SCCR-Nennwerte für Hauptschalter/Kombinationssmotorregler und Netztrennschalter finden Sie im Projektierungshandbuch.

5. Überprüfen Sie die Spezifikationen des Leistungskabels. Siehe Schritt 3 im Abschnitt Abbildungen.

Verwenden Sie Kupferdraht mit einem Nennwert von mindestens 70 °C für die Gehäuse Fx02–Fx07 und 90 °C für Gehäuse des Typs Fx08. Für Aluminiumdraht siehe Projektierungshandbuch.

6. Installieren Sie den Frequenzrichter gemäß den nummerierten Schritten im Abschnitt Abbildungen. Bestimmte Abbildungen/Schritte beziehen sich auf bestimmte Baugrößen und sind entsprechend gekennzeichnet. Treffen Sie auf alle Var-

ianten zu, so wird das 2. Zeichen in der Baugrößenbezeichnung durch ein x ersetzt, sodass z. B. Fx06 die Baugrößen FA06, FB06 und FK06 angibt.

- a. Befestigen Sie die Komponenten des Montagezubehörs am Frequenzumrichter (Schritt 4).
- b. Montieren Sie den Frequenzumrichter auf oder an einer festen, nicht brennbaren Montagefläche wie Beton oder Metall (Schritt 5). Sorgen Sie für ausreichende Kühlung, indem Sie einen freien Mindestabstand über und unter dem Frequenzumrichter einhalten.
- c. Bohren Sie bei den Baugrößen FK06–FK08 Kabelöffnungen in die Kabeleinführungsplatte und montieren Sie die Kabelverschraubungen (Schritt 6).
- d. Installieren Sie die Steuerleitungen (Schritt 7).
- e. Installieren Sie die Motor-, Netz- und Schutzerdungskabel (Schritt 8).
- f. Verlegen Sie die Steuerleitungen (Schritt 9).

7. Befestigen Sie die Abdeckung sicher am Frequenzumrichter.
8. Führen Sie die Ersteinrichtung von Frequenzumrichter und Motor durch. Lesen Sie die *Anwendungsanleitung der IC7-Serie für Industrieanwendungen*.
9. Konfigurieren Sie den Feldbus. Lesen Sie die *Feldbus-Anwendungsanleitung der IC7-Serie*.

1.6 Funktionale Sicherheit (Safe Torque Off)

Bei Auslieferung sind alle Sicherheitseingänge des Frequenzumrichters abgeschaltet. Ohne zusätzliche Verdrahtung an den Sicherheits-E/A-Klemmenblöcken (X31 und X32) ist die STO-Funktion immer aktiv und der Motor dreht sich nicht.

- Installieren Sie zur Deaktivierung der STO-Funktion Drahtbrücken an den Klemmen X31 und X32. Siehe Schritt 7.
- Verdrahten Sie zur Verwendung der STO-Funktion eine Sicherungseinrichtung an einem oder beiden der Sicherheits-E/A-Klemmenblöcke. Siehe Schritt 1. Zur Verhinderung unzutreffender Fehler oder Warnungen müssen alle nicht verwendeten Sicherheits-E/A-Klemmenblöcke mit Drahtbrücken oder einer Steckbrückenklemme deaktiviert werden. Eine Steckbrückenklemme ist im Montagezubehör enthalten.

Weitere Informationen finden Sie in der *Bedienungsanleitung zur funktionalen Sicherheit der IC7-Serie (136R0268)*.

⚠ W A R N U N G ⚠

RESTDREHUNG

Sie können die STO-Funktion für asynchrone, synchrone und Permanentmagnetmotoren verwenden. Im Leistungshalbleiter des Frequenzumrichters können zwei Fehler auftreten. Bei Verwendung synchroner oder Permanentmagnetmotoren kann dies zu einer Restdrehung führen. Die Drehung ergibt sich mit Winkel = 360/(Polzahl). Bei Anwendungen, die synchrone oder Permanentmagnetmotoren einsetzen, müssen Sie die Restdrehung berücksichtigen und sicherstellen, dass dadurch kein sicherheitskritisches Problem entsteht. Dies trifft nicht auf Asynchronmotoren zu.

H I N W E I S

Nach der Erstinstallation und jeder darauf folgenden Änderung der Installation oder Anwendung, bei der die STO-Funktion beteiligt ist, ist eine erfolgreiche Inbetriebnahmeprüfung der STO-Funktion erforderlich.

Inbetriebnahmeprüfung

Es gibt zwei Arten von Inbetriebnahmeprüfungen, je nachdem, wie der STO-Parameter konfiguriert ist. Weitere Informationen zum STO-Parameter finden Sie in der *Anwendungsanleitung*.

- Wenn der Parameter 7.2.1 *Safe Torque Off Response auf „Fehler, Reset erforderlich“ steht*, führen Sie die mit „M“ gekennzeichneten Inbetriebnahmeschritte durch.
- Wenn der Parameter 7.2.1 *Safe Torque Off Response auf „Warnung, kein Reset erforderlich“ steht*, führen Sie die mit „A“ gekennzeichneten Inbetriebnahmeschritte durch.

Tabelle 1: Inbetriebnahmeprüfung für STO-Funktion

Art der Prüfung	Inbetriebnahmeschritte	X
M/A	Den Frequenzumrichter einschalten.	<input type="checkbox"/>
M/A	Stellen Sie sicher, dass keine Sicherheitsfehler vorliegen.	<input type="checkbox"/>

Art der Prüfung	Inbetriebnahmeschritte	X
M/A	Starten Sie den Motor.	<input type="checkbox"/>
M/A	Trennen Sie über die Sicherungseinrichtung die 24-V-DC-Spannungsversorgung von beiden STO-Eingangsklemmen, ohne die Netzversorgung zu unterbrechen.	<input type="checkbox"/>
M/A	Stellen Sie sicher, dass der Motor in den Freilauf geht. Dieser Vorgang kann einige Zeit in Anspruch nehmen.	<input type="checkbox"/>
M/A	Überprüfen Sie, dass an der Bedieneinheit oder im Ereignisprotokoll STO aktiviert angezeigt wird.	<input type="checkbox"/>
M/A	Überprüfen Sie bei Verwendung des STO-Rückmeldungssignals, dass STO aktiviert ist, indem Sie den Status der STO-Rückmeldung überprüfen.	<input type="checkbox"/>
M/A	Legen Sie die 24-V-DC-Versorgungsspannung wieder an die beiden STO-Eingangsklemmen an.	<input type="checkbox"/>
M/-	Stellen Sie sicher, dass der Motor im Freilauf und angeschlossene Relais aktiviert bleiben.	<input type="checkbox"/>
M/-	Senden Sie ein Reset-Signal über Feldbus, Digital-E/A oder die Bedieneinheit.	<input type="checkbox"/>
M/A	Stellen Sie sicher, dass der Motor anläuft und innerhalb des ursprünglichen Drehzahlbereichs läuft.	<input type="checkbox"/>

1.7 Leistungsverluste und Wirkungsgrad

Informationen zu Leistungsverlusten, inklusive Teillastverlusten, finden Sie unter <https://ecosmart.mydrive.danfoss.com>.

1 Instructions

1.1 Sensibilisation à la sécurité et à l'installation

Un guide d'installation rapide et un guide de sécurité sont fournis avec le variateur. Avant de commencer l'installation, lire toutes les consignes et précautions de sécurité figurant dans le guide de sécurité (136R0243). Pour plus de détails sur la cybersécurité, voir Fonctionnalités de sécurité dans le guide d'application (136R0283). Des ressources supplémentaires, notamment un manuel de configuration, un guide d'application et un guide d'installation complet, sont disponibles au téléchargement à l'adresse www.danfoss.com/service-and-support.

1.2 Outils nécessaires

- Aide au levage
- Mètre-ruban
- Clé avec rallonge et douille de 10 mm
- Tournevis Torx et vis à fente (T15, T20, T25, T30, T50, SL1 et SL2)
- Pince à sertir
- Poinçon pour tôle et/ou pince pour plaque d'entrée des câbles

1.3 Vérification de l'expédition et du contenu

S'assurer que les éléments fournis et les informations disponibles sur l'étiquette du produit correspondent à la commande. L'étiquette du produit se trouve sur le dessus du variateur.

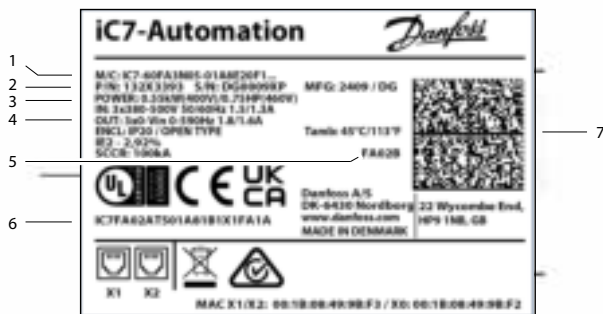

Illustration 1: Exemple d'étiquette de produit

1	Code du modèle	5	Code 2D – consultable à l'aide d'un lecteur de codes-barres compatible Datamatrix ECC 200 – contenant le code du modèle, le code produit, le numéro de série et la date de fabrication
2	Référence, numéro de série et date de fabrication (AAMM)	6	Désignation du châssis
3	Dimensionnement puissance	7	Code de conformité
4	Tension, fréquence et courant d'entrée et de sortie		

1.4 Installation conforme aux critères CEM

Pour une installation conforme aux critères CEM, voir le manuel de configuration ou d'utilisation et suivre les instructions d'installation électrique.

- Utiliser des câbles blindés pour l'alimentation du moteur (des câbles non blindés dans un conduit métallique sont également acceptables), le frein, CC et le câblage de commande.
- Raccorder le blindage au boîtier aux deux extrémités. Si les points de raccordement du blindage présentent une différence de potentiel de tension, connecter un fil d'égalisation à faible impédance parallèlement au câble blindé. Sinon, rompre la connexion du blindage à une extrémité pour empêcher les boucles de courant à la terre.
- Veiller à utiliser des câbles moteur, du frein et CC aussi courts que possible pour réduire le niveau d'interférences émises par le système dans son ensemble.
- Si possible, prévoir au moins 200 mm (7,9 po) de séparation entre les câbles réseau, les câbles moteur et les câbles de commande.
- Réacheminer les courants vers l'unité à l'aide d'une plaque CEM. Assurer un bon contact électrique à partir de la plaque CEM à travers les vis de montage et jusqu'au châssis du variateur.
- Les pièces identifiées par (!) doivent être installées. Voir l'étape 4 de la section Illustrations.

1.5 Installation du variateur

▲ AVERTISSEMENT ▲

RISQUE DE CHOC ÉLECTRIQUE

Tout contact avec un moteur non isolé, l'alimentation secteur, une fiche de raccordement CC ou une borne peut entraîner des blessures graves, voire mortelles.

- Tous les connecteurs et capots de protection des bornes pour les connexions du moteur, du réseau et CC doivent être installés dans la protection IP20 pour assurer une protection nominale IP20. Si la fiche et les caches du bornier ne sont pas installés, la protection nominale est considérée IP00.

L'emplacement d'installation est important.

Le courant de sortie total est disponible lorsque les conditions d'installation suivantes sont remplies. Pour les températures et altitudes en dehors de cette plage, voir la section Déclassement du manuel de configuration.

- Température maximale de l'air ambiant : 45 °C (113 °F) en moyenne sur 24 heures et 50 °C (122 °F) pendant 1 heure.
- Température minimale de l'air ambiant : -30 °C (-22 °F).
- Altitude < 1 000 m (3 280 pi) au-dessus du niveau de la mer.

Procédure

1. Identifier la taille du châssis. Voir [Illustration 3](#).
2. Vérifier que l'environnement de fonctionnement et l'installation électrique répondent aux normes suivantes.
 - a. Intérieur non climatisé/degré de pollution 2.
 - b. Catégorie de surtension 3.
3. Examiner le schéma de câblage. Voir l'étape 1 de la section Illustrations.

L'ensemble du câblage doit être conforme aux réglementations nationales et locales en matière de sections de câble et de température ambiante. Des raccordements desserrés peuvent être à l'origine de défauts de l'équipement ou d'une baisse des performances. Serrer les bornes en respectant le couple de serrage approprié indiqué à l'étape 8.

4. Vérifier les spécifications des fusibles. Voir l'étape 2 de la section Illustrations.

Le variateur peut être utilisé sur un circuit capable de délivrer un courant nominal de court-circuit allant jusqu'à 100 kA, à la tension nominale respective du variateur. Pour les caractéristiques nominales SCCR de l'interrupteur-sectionneur et du disjoncteur moteur, voir le manuel de configuration.

5. Examiner les spécifications du câble de puissance. Voir l'étape 3 de la section Illustrations.

Utiliser un fil de cuivre d'une valeur nominale minimale de 70 °C (158 °F) pour les protections Fx02-Fx07, et de 90 °C (194 °F) pour les protections Fx08. Pour un fil en aluminium, voir le manuel de configuration.

6. Installer le variateur en suivant les étapes numérotées de la section Illustrations. Certaines illustrations/étapes se rapportent à la désignation du châssis et sont signalées comme telles. Si l'illustration ou l'étape s'applique à toutes les variantes, le 2e caractère de la désignation du châssis est remplacé par un x – par exemple Fx06 indique FA06, FB06 et FK06.
 - a. Fixer les éléments du sac d'accessoires au variateur (étape 4).
 - b. Monter le variateur sur ou contre une surface de montage solide et non combustible, comme du béton ou du métal (étape 5). Assurer un refroidissement correct en laissant un dégagement minimum au-dessus et en dessous du variateur.
 - c. Pour les châssis FK06-FK08, percer des orifices de câble dans la plaque d'entrée des câbles et installer les presse-étoupes (étape 6).
 - d. Installer le câblage de commande (étape 7).
 - e. Installer le câblage du moteur, du réseau et de terre de protection (étape 8).
 - f. Acheminer les câbles de commande (étape 9).
7. Fixer solidement le capot au variateur.
8. Effectuer la configuration initiale du variateur et du moteur. Consulter le *guide d'application Industrie de la série iC7*.
9. Configurer le bus de terrain. Consulter le *guide d'application de bus de terrain de la série iC7*.

1.6 Sécurité fonctionnelle (Safe Torque Off)

Le variateur est livré avec toutes les entrées de sécurité hors tension. Sans câblage supplémentaire vers les borniers d'E/S de sécurité (X31 et X32), la fonction STO est toujours active et le moteur ne tourne pas.

- Pour désactiver la fonction STO, installer des cavaliers sur les bornes X31 et X32. Voir l'étape 7.
- Pour utiliser la fonction STO, raccorder un dispositif de sécurité à l'un des borniers d'E/S de sécurité ou aux deux. Voir l'étape 1. Pour éviter les défauts ou les avertissements erronés, il convient de désactiver les borniers d'E/S de sécurité inutilisés à l'aide de fils cavaliers ou d'une pince cavalier. Un cavalier est inclus dans le sac d'accessoires.

Pour plus d'informations, voir le *Manuel d'utilisation de la sécurité fonctionnelle de la série IC7* (136R0268).

▲ A V E R T I S S E M E N T ▲

ROTATION RÉSIDUELLE

La fonction STO peut être utilisée pour les moteurs synchrones, asynchrones et les moteurs à magnétisation permanente. Deux défauts peuvent survenir dans le semi-conducteur de puissance du variateur. Lorsque des moteurs synchrones ou des moteurs à magnétisation permanente sont utilisés, une rotation résiduelle peut provenir de défaillances. La rotation peut être calculée comme suit : $\text{angle} = 360 / (\text{nombre de pôles})$. L'application utilisant des moteurs synchrones ou à magnétisation permanente doit tenir compte de cette rotation résiduelle et veiller à ce qu'il n'y ait pas de risque en termes de sécurité. Cette situation ne concerne pas les moteurs asynchrones.

R E M A R Q U E

Un essai de mise en service réussi de la fonction STO est nécessaire après l'installation initiale et après chaque modification ultérieure de l'installation ou de l'application utilisant la fonction STO.

Essai de mise en service

Il existe deux types d'essais de mise en service en fonction de la configuration du paramètre STO. Pour plus d'informations sur le paramètre STO, voir le guide d'application.

- Si le paramètre 7.2.1 Réponse Safe Torque Off = Défaut, *reset requis*, effectuer les étapes de mise en service marquées d'un « M ».
- Si le paramètre 7.2.1 Réponse Safe Torque Off = Avertissement, *aucun reset requis*, effectuer les étapes de mise en service marquées d'un « A ».

Tableau 1: Essai de mise en service de la fonctionnalité STO

Type d'essai	Étapes de mise en service	X
M/A	Mettre le variateur de fréquence sous tension.	<input type="checkbox"/>
M/A	Vérifier qu'il n'y a pas de défaut de sécurité.	<input type="checkbox"/>
M/A	Démarrer le moteur.	<input type="checkbox"/>
M/A	Sans couper l'alimentation réseau, couper l'alimentation 24 V CC des deux bornes d'entrée STO à l'aide du dispositif de sécurité.	<input type="checkbox"/>
M/A	Vérifier que le moteur tourne en roue libre. Ce processus peut prendre un certain temps.	<input type="checkbox"/>
M/A	Vérifier que STO activé s'affiche sur le panneau de commande ou dans le journal des événements.	<input type="checkbox"/>
M/A	Si le retour STO est utilisé, vérifier que la fonction STO est activée en vérifiant l'état du retour STO.	<input type="checkbox"/>
M/A	Rétablir l'alimentation 24 V CC aux deux bornes d'entrée STO.	<input type="checkbox"/>
M/-	Vérifier que le moteur demeure en état de roue libre et que tous les relais raccordés restent activés.	<input type="checkbox"/>
M/-	Envoyer un signal de reset via le bus de terrain, l'E/S numérique ou le panneau de commande.	<input type="checkbox"/>
M/A	Vérifier que le moteur démarre et tourne dans la plage de vitesse d'origine.	<input type="checkbox"/>

1.7 Pertes de puissance et efficacité

Pour les données de perte de puissance, y compris les pertes à charge partielle, voir <https://ecosmart.mydrive.danfoss.com>.

1 Istruzioni

1.1 Consapevolezza in materia di sicurezza e installazione

Insieme al convertitore di frequenza vengono fornite una guida di installazione rapida e una guida alla sicurezza. Prima di iniziare l'installazione, leggere tutte le linee guida e le precauzioni di sicurezza contenute nella guida alla sicurezza (136R0243). Per dettagli sulla sicurezza informatica, vedere Caratteristiche di sicurezza nella guida applicativa (136R0283). Ulteriori risorse, tra cui una guida alla progettazione, una guida applicativa e una guida di installazione completa, possono essere scaricate all'indirizzo www.danfoss.com/service-and-support.

1.2 Utensili richiesti

- Ausilio di sollevamento
- Metro a nastro
- Brugola con prolunga e presa da 10 mm
- Cacciaviti Torx e a intaglio (T15, T20, T25, T30, T50, SL1 e SL2)
- Crimpatrice per cavi
- Punzone e/o pinza punzonatrice per piastra ingresso cavo

1.3 Verifica della spedizione e del contenuto

Assicurarsi che gli elementi forniti e le informazioni sulle etichette del prodotto corrispondano alla conferma d'ordine. L'etichetta del prodotto si trova sulla sommità del convertitore di frequenza.



Illustrazione 1: Esempio di etichetta di un prodotto

<p>1 Codice modello</p> <p>2 Codice articolo, numero seriale e data di fabbricazione (AASS)</p> <p>3 Potenza nominale</p> <p>4 Tensione, frequenza e corrente di ingresso e di uscita</p>	<p>5 Codice 2D - accessibile tramite un lettore di codici a barre compatibile con Datamatrix ECC 200 - contenente il codice modello, il codice articolo, il numero seriale e la data di fabbricazione</p> <p>6 Sigla frame</p> <p>7 Codice di conformità</p>
---	--

1.4 Impianto conforme ai requisiti EMC

Per un'installazione conforme ai requisiti EMC, fare riferimento alla Guida alla Progettazione o al funzionamento e seguire le istruzioni per l'installazione elettrica.

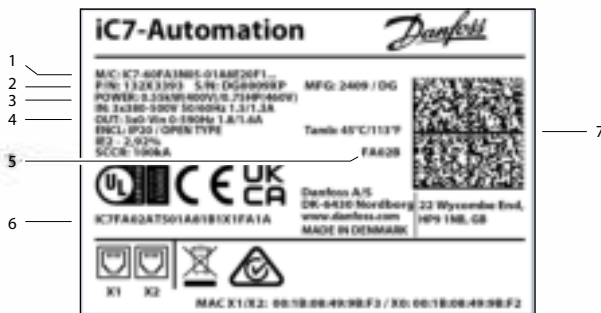
- Usare cavi schermati per l'uscita motore (sono ammessi cavi non schermati in canaline metalliche), il freno, i cavi CC e i cavi di controllo.
- Collegare lo schermo dei contenitori a entrambe le estremità. Se i punti di collegamento dello schermo presentano potenziali di tensione differenti, collegare un filo di equalizzazione a bassa impedenza parallelamente al cavo schermato. In caso contrario, interrompere il collegamento dello schermo a una delle estremità per evitare correnti di terra ad anello.
- Assicurarsi che i cavi motore, i cavi del freno e i cavi CC siano il più possibile corti per ridurre il livello di interferenza dell'intero sistema.
- Se possibile, fornire uno spazio minimo di 200 mm (7,9 pollici) tra cavi di ingresso della rete, cavi motore e cavi di comando.
- Ricodurre le correnti nell'unità con una piastra EMC. È necessario assicurare un buon contatto elettrico dalla piastra EMC allo chassis del convertitore di frequenza per mezzo delle viti di montaggio.
- Le parti identificate con (!) devono essere installate. Vedere il passaggio 4 della sezione Illustrazioni.

1.5 Installazione del convertitore di frequenza

⚠ AVVISO ⚠

PERICOLO DI SCOSSE

Toccare un motore, una rete, una connettore di collegamento CC o un morsetto scoperto può causare la morte o lesioni gravi.

- Per ottenere un grado di protezione IP20, è necessario che tutti i tappi e i coprimorsetti di protezione per i collegamenti del motore, della rete e CC siano installati all'interno del contenitore IP20. Se il tappo e i coprimorsetti non sono installati, il grado di protezione è IP00.

La posizione di installazione è importante.

La piena corrente di uscita è disponibile quando sono soddisfatte le seguenti condizioni di installazione. Per temperature e altitudini al di fuori di questo intervallo, consultare le sezioni Declassamento nella Guida alla Progettazione.

- Temperatura aria ambiente massima: 45 °C (113 °F) in media nelle 24 ore e 50 °C (122 °F) per 1 ora.
- Temperatura aria ambiente minima: -30 °C (-22 °F).
- Altitudine <1.000 m (3.280 piedi) sopra il livello del mare.

Procedura

1. Individuare la sigla frame. Vedere [Illustrazione 4](#).
2. Verificare che l'ambiente operativo e l'installazione elettrica soddisfino i seguenti standard.
 - a. Interni non condizionati/grado di inquinamento 2.
 - b. Categoria di sovratensione 3.

3. Esaminare lo schema elettrico. Vedere il passaggio 1 nella sezione Illustrazioni.

Tutti i fili devono essere conformi alle norme locali e nazionali relative ai requisiti in termini di sezioni trasversali e temperature ambiente. Collegamenti allentati possono causare guasti all'apparecchiatura o prestazioni ridotte. Serrare i morsetti secondo il valore di coppia corretto mostrato nel passaggio 8.

4. Rivedere le specifiche dei fusibili. Vedere il passaggio 2 nella sezione Illustrazioni.

Questo convertitore di frequenza può essere adatto per l'uso su un circuito in grado di fornire 100 kA di corrente nominale di cortocircuito (SCCR) alla rispettiva tensione nominale del convertitore. Per i gradi SCCR dell'interruttore/controllore motore combinato e del sezionatore di rete, consultare la guida alla progettazione.

5. Rivedere le specifiche del cavo di potenza. Vedere il passaggio 3 della sezione Illustrazioni.

Utilizzare un filo di rame con un grado minimo di 70 °C (158 °F) per contenitori Fx02-Fx07 e 90 °C (194 °F) per contenitori Fx08. Per il conduttore in alluminio, vedere la guida alla progettazione.

6. Installare il convertitore di frequenza seguendo i passaggi numerati della sezione Illustrazioni. Alcune illustrazioni/fasi riguardano denominazioni specifiche del telaio e sono contrassegnate come tali. Se è valida per tutte le varianti, il secondo carattere nella sigla frame viene sostituito da una x, ad esempio Fx06, che indica FA06, FB06 e FK06.

- a. Fissare al convertitore di frequenza i componenti della busta per accessori (passaggio 4)
 - b. Montare il convertitore di frequenza su o contro una superficie di montaggio solida e non combustibile, come cemento o metallo (passaggio 5). Assicurare un corretto raffreddamento fornendo uno spazio minimo sopra e sotto il convertitore di frequenza.
 - c. Per i frame FK06-FK08, praticare dei fori per i cavi nella piastra ingresso cavo e montare i pressacavo (passaggio 6).
 - d. Installare i cavi di controllo (passaggio 7).
 - e. Installare i cavi motore, di rete e di messa a terra PE (passaggio 8).
 - f. Posare i cavi di comando (passaggio 9).
7. Fissare saldamente il coperchio al convertitore di frequenza.
 8. Eseguire l'impostazione iniziale del convertitore di frequenza e del motore. Consultare la *Guida alle applicazioni industriali della serie iC7*.
 9. Configurare il bus di campo Consultare la *Guida all'applicazione bus di campo serie iC7*.

1.6 Sicurezza funzionale (Safe Torque Off)

Il convertitore di frequenza viene spedito con tutti gli ingressi sicuri disecchitati. Senza cablaggio supplementare alle morsettiere I/O di sicurezza (X31 e X32), la funzione STO è sempre attiva e il motore non gira.

- Per disabilitare la funzione STO, collegare i cavi del ponticello ai morsetti X31 e X32. Vedere il passaggio 7.
- Per utilizzare la funzione STO, collegare un dispositivo di sicurezza a una o a entrambe le morsettiere I/O sicure. Vedere il passaggio 1. Per evitare guasti o avvisi errati, tutte le morsettiere I/O sicure inutilizzate devono essere disabilitate utilizzando cavi a ponticello o una clip per ponticello. Nella busta per accessori è inclusa una clip per ponticello.

Per ulteriori informazioni, fare riferimento alla *Guida operativa per la sicurezza funzionale della serie iC7* (136R0268).

⚠ AVVISO ⚠

ROTAZIONE RESIDUA

La funzione STO può essere utilizzata per motori asincroni, sincroni e a magneti permanenti. Nel semiconduttore di potenza del convertitore di frequenza possono verificarsi due guasti. Quando si utilizzano motori sincroni o a magneti permanenti, i guasti possono causare una rotazione residua. La rotazione può essere calcolata come $\text{angolo} = 360/(\text{numero di poli})$. L'applicazione che fa uso di motori sincroni o a magneti permanenti deve tenere conto di questa rotazione residua e assicurarsi che non costituisca un rischio per la sicurezza. Tale situazione non è pertinente ai motori asincroni.

NOTA

È necessario un test riuscito di messa in funzione della STO dopo l'installazione iniziale e dopo ogni modifica successiva dell'impianto che richieda l'impiego della stessa.

Test di messa in funzione

Esistono due tipi di test di messa in funzione in base alla configurazione del parametro STO. Per ulteriori informazioni sul parametro STO, vedere la guida applicativa.

- Se il parametro 7.2.1 *Safe Torque Off Response = Fault, reset required* (Risposta Safe Torque Off = Errore, ripristino necessario), eseguire le fasi di messa in funzione contrassegnate con una "M".
- Se il parametro 7.2.1 *Safe Torque Off Response = Warning, no reset required* (Risposta Safe Torque Off = Avviso, non è necessario alcun ripristino), eseguire le fasi di messa in funzione contrassegnate con una "A".

Tabella 1: Test di messa in funzione per la funzionalità STO

Tipo di test	Fasi della messa in funzione	X
M/A	Accendere il convertitore di frequenza.	<input type="checkbox"/>
M/A	Verificare che non siano presenti guasti di sicurezza.	<input type="checkbox"/>
M/A	Avviare il motore.	<input type="checkbox"/>
M/A	Senza interrompere l'alimentazione di rete, rimuovere la tensione di alimentazione a 24 V CC da entrambi i morsetti di ingresso STO usando il dispositivo di sicurezza.	<input type="checkbox"/>
M/A	Verificare che il motore giri a ruota libera. Questo processo può richiedere del tempo.	<input type="checkbox"/>

Tipo di test	Fasi della messa in funzione	X
M/A	Verificare che "STO attivata" sia visualizzato sul pannello di controllo o nel registro eventi.	<input type="checkbox"/>
M/A	Se si utilizza la retroazione STO, verificare che la funzione STO sia attivata controllando lo stato della stessa.	<input type="checkbox"/>
M/A	Riapplicare l'alimentazione a 24 V CC a entrambi i morsetti di ingresso STO.	<input type="checkbox"/>
M/-	Verificare che il motore rimanga in rotazione libera e che tutti i relè collegati rimangano attivati.	<input type="checkbox"/>
M/-	Inviare un segnale di ripristino tramite bus di campo, I/O digitale o pannello di controllo.	<input type="checkbox"/>
M/A	Verificare che il motore si avvii e funzioni nell'intervallo di velocità originale.	<input type="checkbox"/>

1.7 Perdite di potenza ed efficienza

Per i dati sulle perdite di potenza, quali le perdite di carico parziali, vedere <https://ecosmart.mydrive.danfoss.com>.

1 指示

1.1 安全与安装基础

变频器随附有快速安装指南和安全指南。在开始安装之前, 请阅读安全指南 (136R0243) 中的所有安全准则及预防措施。有关网络安全安全的详细信息, 请参阅应用指南 (136R0283) 中的安全功能。其他资源 — 包括设计指南、应用指南和综合安装指南 — 可从 www.danfoss.com/service-and-support 下载。

1.2 所需工具

- ✦ 起吊辅助装置
- ✦ 卷尺
- ✦ 带加长手柄和 10 mm 套筒的扳手
- ✦ 梅花形和一字螺丝刀 (T15、T20、T25、T30、T50、SL1 和 SL2)
- ✦ 压线钳
- ✦ 用于电缆入口板的金属板冲头和/或钳子

1.3 验货

确保交付的物品和铭牌上的信息与订单确认表一致。产品标签贴在变频器顶部。

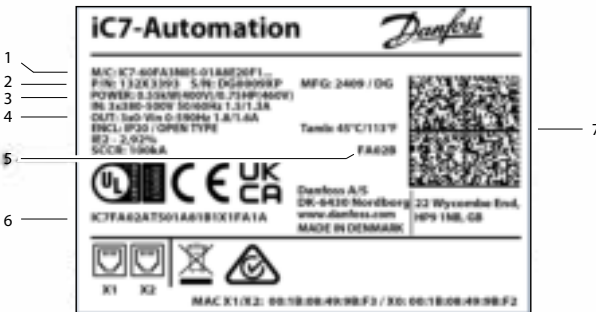

图例 1: 产品标签示例

1	型号代码	5	二维码 — 可使用兼容 Datamatrix ECC 200 的条码阅读器访问 — 包含型号代码、货号、序列号和生产日期
2	货号、序列号和生产日期 (YYWW)	6	机架名称
3	额定功率	7	备件代码
4	输入和输出电压、频率和电流		

1.4 符合 EMC 规范的安装

要进行符合 EMC 规范的安装，请参考操作或设计指南，并遵循电气安装说明。

- 对电机输出、制动、直流和控制线路使用屏蔽电缆（也可以使用位于金属导管中的非屏蔽电缆）。
- 将屏蔽层的两端都连接到机箱。如果屏蔽连接点间存在电位差，请将低阻抗均压线与屏蔽电缆并行连接。否则，断开一端的屏蔽层连接，以防出现接地电流回路。
- 确保电机、制动和直流电缆尽可能短，以降低整个系统的干扰水平。
- 可能情况下，应保持主电源输入、机电缆和控制电缆之间至少间隔 200 mm (7.9 in)。
- 使用 EMC 板将电流传送回设备。确保从 EMC 板、固定螺钉再到变频器机架都保持良好的电气接触。
- 必须安装标有 (!) 的零件。请见“图表”部分的第 4 步。

1.5 安装变频器

⚠ 警告 ⚠

触电危险

触摸未加盖的电机、主电源或直流连接插头或端子会导致严重伤亡。

- 所有用于电机、主电源和直流连接的插头和端子保护盖都必须安装在 IP20 机箱内，以提供 IP20 防护等级。如果未安装插头和端子盖，则防护等级为 IP00。

安装位置很重要。

满足以下安装条件时，将提供完全输出电流。如果温度和海拔高度超出此范围，请参阅设计指南中的“降额”一节。

- 最高环境空气温度：24 小时内平均气温为 45 °C (113 °F)、1 小时内平均气温为 50 °C (122 °F)。
- 最低环境空气温度：-30 °C (-22 °F)。
- 海拔不超过 1000 米 (3280 英尺)。

步骤

- 确定机架名称。请参考 [图解 5](#)。
- 检查工作环境和电气安装是否符合以下标准。
 - 室内无空调 / 污染等级 2。
 - 过压类别 3。
- 查看接线图。请参见“图表”部分中的第 1 步。

所有接线都必须符合国家和地方法规中关于横截面积和环境温度的要求。连接松动会导致设备故障或降低性能。按第 8 步所示的正确转矩值拧紧端子。

- 查看保险丝规格。请参见“图表”部分中的第 2 步。

本变频器适用于在相应的变频器额定电压下最高可提供 100 kA 短路电流额定值的电路。有关断路器/组合电机控制器和主电源隔离开关 SCCR 额定值的信息，请参阅设计指南。

- 查看电源线规格。请参见“图表”部分中的第 3 步。

对于 Fx02-Fx07 机箱，使用额定温度至少为 70 °C (158 °F) 的铜线，对于 Fx08 机箱，使用额定温度至少为 90 °C (194 °F) 的铜线。有关铝线的信息，请参阅设计指南。

- 按照“图表”部分所述的步骤安装变频器。一些图表/步骤与特定机箱规格有关，并进行了相应标记。如果适用于所有型号，机架名称中的第 2 个字符将被替换为 X，例如 Fx06，表示 FA06、FB06 和 FK06。
 - 将附件包组件连接到变频器（第 4 步）。

- b. 将变频器安装在不可燃的实心安装表面上，比如混凝土或金属（第 5 步）。在变频器上方和下方留出最小间隙，确保能够进行冷却。
 - c. 对于机架 FK06-FK08，在电缆入口板上钻出电缆开口，然后安装电缆线管（第 6 步）。
 - d. 安装控制线缆（第 7 步）。
 - e. 安装电机线缆、主电源线缆和保护接地线（第 8 步）。
 - f. 敷设控制电缆（第 9 步）。
7. 将盖板牢固固定在变频器上。
 8. 对变频器和电机进行初始设置。请参阅 iC7 系列工业应用指南。
 9. 配置现场总线。请参阅 iC7 系列现场总线应用指南。

1.6 功能安全（安全转矩关断）

装运变频器时，所有安全输入都处于断电状态。若未对安全 I/O 接线端子（X31 和 X32）进行额外接线，STO 功能始终处于激活状态，并且电机将不会转动。

- 要禁用 STO 功能，请将跳线安装到端子 X31 和 X32 上。参见步骤 7。
- 要使用 STO 功能，请将一个安全装置连接到一个或两个安全 I/O 接线端子。参见步骤 1。为防止出现错误故障或警告，必须使用跳线或跳线夹禁用任何未使用的安全 I/O 接线端子。附件包中包含一个跳线夹。

有关详细信息，请参考 iC7 系列功能安全操作指南 (136R0268)。

▲ 警告 ▲

残余旋转

STO 功能可用于异步、同步和永磁式电机。变频器的功率半导体内可能发生两种故障。在使用同步或永磁电机时，故障情况可能引起残余旋转。旋转度可以按下述方式计算：角度=360/(极数)。在使用同步或永磁电机的应用中必须考虑这种残余旋转问题，并确保这不会导致安全风险。异步电机不存在此问题。

注意

初次安装以及随后每次对安装或涉及 STO 的应用程序进行更改后，都必须对 STO 功能执行成功的调试测试。

调试测试

根据 STO 参数的配置方式，可以执行 2 种类型的调试测试。有关 STO 参数的更多信息，请参阅应用指南。

- 如果参数 7.2.1 安全转矩关断响应 = 故障，需要复位，请执行标有 "M" 的调试步骤。
- 如果参数 7.2.1 安全转矩关断响应 = 警告，无需复位，请执行标有 "A" 的调试步骤。

■ 1.1.1.1 故障调试测试

测试类型	调试步骤	X
M/A	为变频器通电。	<input type="checkbox"/>
M/A	确认不存在安全故障。	<input type="checkbox"/>
M/A	启动电机。	<input type="checkbox"/>
M/A	在不断开主电源的情况下，使用安全装置断开两个 STO 输入端子的 24 V 直流电源。	<input type="checkbox"/>
M/A	确认电机是否惯性停车。此过程可能需要一些时间。	<input type="checkbox"/>
M/A	验证控制面板或事件记录中是否指示 STO 已激活。	<input type="checkbox"/>
M/A	如果使用 STO 反馈，则通过检查 STO 反馈的状态来验证 STO 是否激活。	<input type="checkbox"/>
M/A	对两个 STO 输入端子重新施加 24 V 直流电源。	<input type="checkbox"/>

测试类型	调试步骤	X
M/-	确认电机是否保持惯性停车状态，并且连接的继电器保持激活状态。	<input type="checkbox"/>
M/-	通过总线、数字 I/O 或控制面板发送复位信号。	<input type="checkbox"/>
M/A	确认电机是否在原先的速度范围内启动和运行。	<input type="checkbox"/>

1.7 功率损耗和效率

有关功率损耗数据（包括部分负载损耗），请访问 <https://ecosmart.mydrive.danfoss.com>。

1 Instrucciones

1.1 Introducción a la seguridad y la instalación

Con el convertidor de frecuencia se incluyen una guía de instalación rápida y una guía de seguridad. Antes de comenzar la instalación, lea todas las directrices y precauciones de seguridad de la guía de seguridad (136R0243). Para obtener más información sobre la ciberseguridad, consulte el apartado Funciones de seguridad en la guía de aplicación (136R0283). Puede descargar recursos adicionales, como una guía de diseño, una guía de aplicación y una guía de instalación completa, en www.danfoss.com/service-and-support.

1.2 Herramientas necesarias

- Elemento de elevación
- Cinta métrica
- Llave con alargador y vaso de 10 mm
- Destornilladores Torx y ranurados (T15, T20, T25, T30, T50, SL1 y SL2)
- Engastador de cables
- Punzón de chapa metálica o tenazas para la placa de entrada de cables

1.3 Verificación del envío y del contenido

Asegúrese de que los elementos suministrados y la información de las etiquetas de los productos se correspondan con la confirmación del pedido. La etiqueta del producto se encuentra en la parte superior del convertidor.



Ilustración 1: Ejemplo de una etiqueta de producto

1	Código de modelo	5	Código 2D: accesible mediante un lector de códigos de barras compatible con Datamatrix ECC 200, que contiene el código de modelo, el número de serie, el número de pieza y la fecha de fabricación.
2	Número de pieza, número de serie y fecha de fabricación (YYYY)	6	Tipo de bastidor
3	Potencia de salida	7	Código de conformidad
4	Tensión de entrada y salida, frecuencia e intensidad		

1.4 Instalación conforme a EMC

Para una instalación conforme a EMC, consulte la guía de diseño o funcionamiento y siga las instrucciones para la instalación eléctrica.

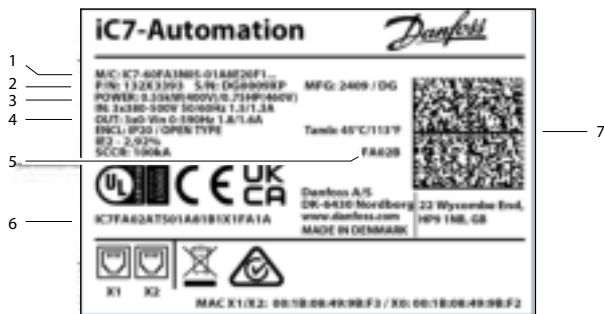
- Utilice cables apantallados para la salida del motor (también se aceptan cables no apantallados en conductos de metal), el freno, la CC y el cableado de control.
- Conecte la pantalla a las protecciones en ambos extremos. Si los puntos de conexión de la pantalla tienen una diferencia de potencial de tensión, conecte un cable ecualizador de baja impedancia en paralelo al cable apantallado. De lo contrario, interrumpa la conexión de la pantalla en un extremo para evitar lazos de corriente a tierra.
- Asegúrese de que los cables del motor, el freno y la CC sean lo más cortos posible para reducir el nivel de interferencias de todo el sistema.
- Si fuera posible, deje un espacio libre mínimo de 200 mm (7,9 in) entre los cables de entrada de alimentación, de motor y de control.
- Devuelva las corrientes a la unidad mediante el uso de una placa EMC. Asegúrese de que la placa EMC y el chasis del convertidor de frecuencia hagan buen contacto eléctrico a través de los tornillos de montaje.
- Las piezas identificadas con (!) deben estar instaladas. Consulte el paso 4 de la sección Ilustraciones.

1.5 Instalación del convertidor

⚠ A D V E R T E N C I A ⚠

RIESGO DE DESCARGA

Tocar un terminal o un enchufe de conexión de CC, red o motor no cubiertos puede provocar lesiones graves o incluso la muerte.

- Todas las cubiertas de protección de los conectores y terminales del motor, la alimentación de red y las conexiones de CC deben instalarse dentro de un alojamiento IP20 para así obtener una clasificación de protección IP20. Si las cubiertas de los conectores y terminales no están instaladas, la clasificación de protección se considera IP00.

La ubicación de la instalación es importante.

La intensidad de salida máxima está disponible cuando se cumplen las siguientes condiciones de instalación. Para temperaturas y altitudes fuera de estos intervalos, consulte los apartados dedicados a la Reducción de potencia en la Guía de diseño.

- Temperatura ambiente máxima del aire: 45 °C (113 °F) de media durante un periodo de 24 horas y 50 °C (122 °F) para un periodo de una hora.
- Temperatura ambiente mínima del aire: -30 °C (-22 °F).
- Altitud <1000 m (3280 pies) sobre el nivel del mar.

Procedimiento

1. Identificación del tipo de bastidor. Consulte [Ilustración 6](#).
2. Asegúrese de que el entorno de funcionamiento y la instalación eléctrica cumplan con las siguientes normas.
 - a. Grado 2 de contaminación/sin acondicionamiento en interiores.
 - b. Categoría de sobretensión 3.
3. Revise el diagrama de cableado. Consulte el paso 1 de la sección Ilustraciones.

Todos los cableados deben cumplir las normas nacionales y locales sobre requisitos de sección transversal y temperatura ambiente. Las conexiones flojas pueden provocar fallos o una reducción del rendimiento en el equipo. Apriete los terminales de acuerdo con el valor de par de apriete correcto que se muestra en el paso 8.

- Revise las especificaciones de los fusibles. Consulte el paso 2 de la sección Ilustraciones.

El convertidor es adecuado para un circuito capaz de proporcionar una intensidad nominal de cortocircuito máxima de 100 kA con la tensión nominal del convertidor correspondiente. Para conocer las clasificaciones SCCR del magnetotérmico/controlador del motor combinado y el interruptor de desconexión de la red eléctrica, consulte la Guía de diseño.

- Revise las especificaciones del cable de alimentación. Consulte el paso 3 de la sección Ilustraciones.

Utilice un cable de cobre con una clasificación mínima de 70 °C (158 °F) para las protecciones Fx02-Fx07 y una clasificación de 90 °C (194 °F) para las protecciones Fx08. Para el cable de aluminio, consulte la Guía de diseño.

- Instale el convertidor de frecuencia siguiendo los pasos numerados en la sección Ilustraciones. Ciertas ilustraciones/pasos hacen referencia a un tipo de bastidor determinado y se identifican como tales. Si se aplica a todas las versiones, el segundo carácter de la designación de bastidor se sustituye por una x, por ejemplo, Fx06, que indica FA06, FB06 y FK06.
 - Fije las piezas de la bolsa de accesorios al convertidor (paso 4).
 - Monte el convertidor sobre o contra una superficie de montaje sólida y no combustible como, por ejemplo, una superficie de hormigón o metal (paso 5). Asegúrese de que la refrigeración sea adecuada dejando un espacio mínimo por encima y por debajo del convertidor.
 - Para los bastidores FK06-FK08, taladre orificios para cables en la placa de entrada de cables e instale los prensacables (paso 6).
 - Instale el cableado de control (paso 7).
 - Instale el cableado del motor, de alimentación de red y de conexión a tierra (paso 8).
 - Tienda los cables de control (paso 9).
- Fije firmemente la cubierta al convertidor.
- Realice el primer accionamiento y ajuste el motor. Consulte la *Guía de aplicación para la industria de la serie iC7*.
- Configure el bus de campo. Consulte la *Guía de aplicación del bus de campo de la serie iC7*.

1.6 Seguridad funcional (Safe Torque Off)

El convertidor se envía con todas las entradas seguras desactivadas. Sin cableado adicional en los bloques de terminales de E/S seguras (X31 y X32), la función STO está siempre activa y el motor no gira.

- Para deshabilitar la función STO, instale cables de puente en los terminales X31 y X32. Consulte el paso 7.
- Para utilizar la función STO, conecte un dispositivo de seguridad a uno o ambos bloques de terminales de E/S seguras. Consulte el paso 1. Para evitar fallos o avisos erróneos, los bloques de terminales de E/S seguras que no se utilicen deben desactivarse utilizando cables de puente o una pinza de puente. En la bolsa de accesorios se incluye una pinza de puente.

Para obtener más información, consulte la *Guía de funcionamiento de seguridad funcional de la serie iC7* (136R0268).

⚠ A D V E R T E N C I A ⚠

ROTACIÓN RESIDUAL

La función STO puede utilizarse con motores síncronos, asíncronos y de magnetización permanente. Pueden producirse dos fallos en el semiconductor de potencia del convertidor de frecuencia. Los fallos pueden provocar una rotación residual si se utilizan motores síncronos o de magnetización permanente. La rotación puede calcularse así: $\text{ángulo} = 360 / (\text{número de polos})$. La aplicación que usa motores síncronos o de magnetización permanente debe tener en cuenta esta rotación residual y garantizar que no suponga ningún riesgo para la seguridad. Esta situación no es relevante para los motores asíncronos.

A V I S O

Tras la instalación o aplicación, y tras cada cambio que se efectúe en la instalación, es necesario llevar a cabo una prueba de puesta en marcha correcta de la función STO.

Prueba de puesta en servicio

Existen dos tipos de pruebas de puesta en servicio basados en la configuración del parámetro STO. Para obtener más información sobre el parámetro STO, consulte la guía de aplicación.

- Si el parámetro 7.2.1 Respuesta de Safe Torque Off = Fallo, restablecimiento necesario, ejecute los pasos de puesta en servicio señalados con una «M».
- Si el parámetro 7.2.1 Respuesta de Safe Torque Off = Advertencia, sin restablecimiento necesario, ejecute los pasos de puesta en servicio señalados con una «A».

Tabla 1: Prueba de puesta en servicio para la función STO

Tipo de prueba	Pasos de la puesta en servicio	X
M/A	Encienda el convertidor de frecuencia.	<input type="checkbox"/>
M/A	Compruebe que no haya ningún fallo de seguridad.	<input type="checkbox"/>
M/A	Ponga en marcha el motor.	<input type="checkbox"/>
M/A	Sin interrumpir la alimentación de red, retire el suministro de tensión de 24 V CC que llega a los terminales de entrada STO mediante el uso del dispositivo de seguridad.	<input type="checkbox"/>
M/A	Compruebe que el motor funcione por inercia. Este proceso puede tardar algo de tiempo.	<input type="checkbox"/>
M/A	Asegúrese de que la función STO activada se muestre en el panel de control o en el registro de eventos.	<input type="checkbox"/>
M/A	Si se utiliza el valor actual de STO, compruebe que la función STO esté activa comprobando el estado del valor actual de STO.	<input type="checkbox"/>
M/A	Vuelva a aplicar un suministro externo de 24 V CC a los dos terminales de entrada de STO.	<input type="checkbox"/>
M/-	Compruebe que el motor permanezca en estado de inercia y que todos los relés conectados permanezcan activos.	<input type="checkbox"/>
M/-	Envíe una señal de reinicio a través de un bus de campo, E/S digital o el panel de control.	<input type="checkbox"/>
M/A	Verifique que el motor arranque y funcione dentro del rango de velocidad original.	<input type="checkbox"/>

1.7 Pérdidas de potencia y eficiencia

Para conocer los datos de pérdida de potencia, incluidas las pérdidas a carga parcial, consulte <https://ecos-mart.mydrive.danfoss.com>.

1 Instruções

1.1 Conscientização sobre segurança e instalação

Um guia de instalação rápido e um guia de segurança são fornecidos com o conversor. Antes de iniciar a instalação, leia todas as orientações e precauções de segurança contidas no guia de segurança (136R0243). Para obter detalhes sobre segurança cibernética, consulte Recursos de segurança no guia de aplicação (136R0283). Recursos adicionais, incluindo o guia de design, o guia de aplicação e um guia de instalação abrangente, podem ser baixados em www.danfoss.com/service-and-support.

1.2 Ferramentas Necessárias

- Auxílio de elevação
- Trena
- Chave com prolongador e soquete de 10 mm
- Chaves Torx e de fenda (T15, T20, T25, T30, T50, SL1, e SL2)
- Crimpador de fios
- Perfurador de chapa metálica e/ou alicate para a placa de entrada de cabos

1.3 Verificação da Entrega e do Conteúdo

Certifique-se de que os itens fornecidos e as informações contidas na etiqueta do produto correspondam à confirmação do pedido. A etiqueta do produto fica localizada na parte superior do conversor.



Ilustração 1: Exemplo de uma etiqueta de produto

1	Código do modelo	5	Código 2D – acessível usando um leitor de código de barras compatível com Datamatrix ECC 200 – contendo o código do modelo, o número de peça, o número de série e a data de fabricação
2	Número de peça, número de série e data de fabricação (AASS)	6	Tipo de chassi
3	Potência nominal	7	Código de conformidade
4	Tensão, frequência e corrente de entrada e saída		

1.4 Instalação compatível com EMC

Para instalações compatíveis com EMC, consulte o guia de design ou de operação e siga as instruções de instalação elétrica.

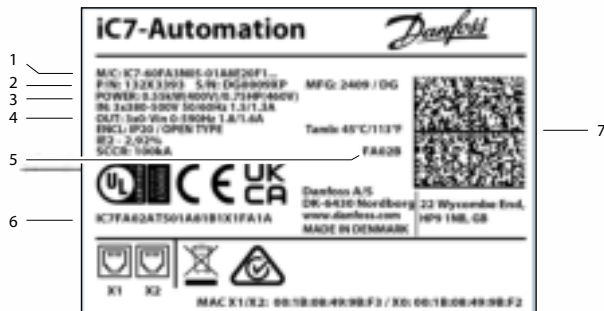
- Use cabos blindados para a saída do motor (são aceitáveis cabos não blindados em conduítes metálicos), freio, CC e fiação de controle.
- Conecte a blindagem aos gabinetes nas duas extremidades. Se houver uma diferença de potencial de tensão nos pontos de conexão da blindagem, conecte um fio de equalização de baixa impedância paralelo ao cabo blindado. Caso contrário, remova a conexão da blindagem em uma extremidade para evitar circuitos de corrente de terra.
- Certifique-se de que os cabos de motor, freio e CC sejam o mais curto possível para reduzir o nível de interferência de todo o sistema.
- Se possível, forneça uma separação mínima de 200 mm (7,9 pol.) entre os cabos de entrada da rede elétrica, cabos do motor e cabos de controle.
- Direcione as correntes de volta a unidade usando uma placa EMC. Garanta um bom contato elétrico da placa EMC através dos parafusos de montagem até o chassi do conversor.
- Peças identificadas com (!) devem ser instaladas. Consulte a etapa 4 na seção Ilustrações.

1.5 Instalação do drive

▲ A D V E R T Ê N C I A ▲

PERIGO DE CHOQUE

Tocar em um motor, rede elétrica ou plugue ou terminal de conexão CC descobertos pode resultar em morte ou lesões graves.

- Todos os plugues e tampas de proteção de terminal de motor, rede elétrica e conexões CC precisam ser instalados dentro do gabinete IP20 para fornecer características nominais de proteção IP20. Sem a instalação do plugue e das tampas de terminal, as características nominais de proteção serão consideradas IP00.

O local de instalação é importante.

A corrente de saída total estará disponível quando estas condições de instalação forem atendidas. Para temperaturas e altitudes fora dessa faixa, consulte a seção de derating no guia de design.

- Temperatura do ar ambiente máxima: Média de 45 °C (113 °F) ao longo de 24 horas, e 50 °C (122 °F) por 1 hora.
- Temperatura do ar ambiente mínima: -30 °C (-22 °F).
- Altitude < 1.000 m (3.280 pés) acima do nível do mar.

Procedimento

1. Identifique o tipo de chassi. Consulte [Ilustração 7](#).
2. Verifique se o ambiente operacional e a instalação elétrica atendem às seguintes normas.
 - a. Interno não condicionado/grau de poluição 2.
 - b. Categoria de sobretensão 3.
3. Revise o diagrama de fiação. Consulte a etapa 1 na seção Ilustrações.

Toda a fiação deverá estar em conformidade com as regulamentações locais e nacionais com relação à seção transversal e aos requisitos de temperatura ambiente. Conexões soltas podem causar falhas no equipamento ou menor desempenho. Aperte os terminais de acordo com o valor de torque adequado mostrado na etapa 8.

4. Revise as especificações do fusível. Consulte a etapa 2 na seção Ilustrações.

O conversor é adequado para uso em um circuito capaz de fornecer características nominais da corrente de curto-circuito de até 100 kA à tensão nominal do respectivo conversor. Para saber as características nominais SCCR do disjuntor/combinção de controlador do motor e chave de desconexão da rede elétrica, consulte o guia de design.

5. Revise as especificações do cabo de energia. Consulte a etapa 3 na seção Ilustrações.

Use fio de cobre com características nominais mínimas de 70 °C (158 °F) para gabinetes metálicos Fx02–Fx07 e características nominais de 90 °C (194 °F) para gabinetes metálicos Fx08. Para fio de alumínio, consulte o guia de design.

6. Instale o conversor seguindo os passos enumerados na seção Ilustrações. Algumas ilustrações/etapas referem-se a tipos de chassi específicos e estão indicadas como tal. Se for aplicável a todas as variantes, o segundo caractere no tipo de chassi é substituído por um x, por exemplo, Fx06, indicando FA06, FB06 e FK06.
 - a. Instale os componentes da sacola de acessórios no conversor (etapa 4).
 - b. Monte o conversor sobre ou junto a uma superfície de montagem sólida e não inflamável, como concreto ou metal (etapa 5). Garanta uma refrigeração adequada fornecendo espaço livre mínimo acima e abaixo do conversor.
 - c. Para chassis FK06–FK08, perfure aberturas para cabos na placa de entrada de cabos e instale os prensa cabos (etapa 6).
 - d. Instale a fiação de controle (etapa 7).
 - e. Instale a fiação do motor, da rede elétrica e de aterramento PE (etapa 8).
 - f. Passe os cabos de controle (etapa 9).
7. Fixe bem a tampa no conversor.
8. Faça a configuração inicial do conversor e do motor. Consulte o *Guia de Aplicação Industry da Série iC7*.
9. Configure o fieldbus. Consulte o *Guia de Aplicação de Fieldbus da Série iC7*.

1.6 Segurança Funcional (Safe Torque Off)

O conversor é enviado com todas as entradas seguras desenergizadas. Sem fiação adicional para os blocos de terminais de E/S segura (X31 e X32), a função STO está sempre ativa e o motor não irá girar.

- Para desabilitar a função STO, instale fios de jumper nos terminais X31 e X32. Consulte a etapa 7.
- Para usar a função STO, conecte um dispositivo de segurança a um ou aos dois blocos de terminais de E/S segura. Consulte a etapa 1. Para evitar que ocorram falhas ou advertências errôneas, qualquer bloco de terminais de E/S segura não utilizado precisa ser desativado usando fios de jumper ou um grampo de jumper. Um grampo de jumper está incluído na sacola de acessórios.

Para obter mais informações, consulte o *Guia de Operação de Segurança Funcional da Série IC7* (136R0268).

A D V E R T Ê N C I A

ROTAÇÃO RESIDUAL

A função STO pode ser usada em motores assíncronos, síncronos e de ímã permanente. Podem ocorrer duas falhas no semicondutor de potência do conversor. Ao usar motores síncronos ou de ímã permanente, uma rotação residual pode resultar das falhas. A rotação pode ser calculada como $\text{ângulo} = 360 / (\text{número de polos})$. A aplicação que usar motores síncronos ou de ímã permanente deve levar em consideração essa rotação residual e assegurar que não representa um risco de segurança. A situação não é relevante para motores assíncronos.

A V I S O

É necessário um teste de comissionamento bem-sucedido da função STO após a instalação inicial e após cada modificação subsequente da instalação ou aplicação envolvendo a função STO.

Teste de Comissionamento

Há dois tipos de teste de comissionamento com base na maneira como o parâmetro de STO é configurado. Para obter mais informações sobre o parâmetro de STO, consulte o guia de aplicação.

- Se *Parâmetro 7.2.1 Resposta do Safe Torque Off = Falha, uma reinicialização será necessária*; execute as etapas de colocação em funcionamento marcadas com um "M".
- Se *Parâmetro 7.2.1 Resposta do Safe Torque Off = Advertência, não será necessário reinicializar*; execute as etapas de colocação em funcionamento marcadas com um "A".

Tabela 1: Teste de colocação em funcionamento da funcionalidade de STO

Tipo de teste	Etapas de comissionamento	X
M/A	Ligue o conversor de frequência.	<input type="checkbox"/>
M/A	Verifique se não há falhas de segurança presentes.	<input type="checkbox"/>
M/A	Dê a partida no motor.	<input type="checkbox"/>
M/A	Sem interromper a alimentação de rede elétrica, remova a alimentação de tensão de 24 V CC dos terminais de entrada de STO por meio do dispositivo de segurança.	<input type="checkbox"/>
M/A	Verifique se o motor para por inércia. Esse processo pode levar algum tempo.	<input type="checkbox"/>
M/A	Verifique se STO ativado é mostrado no painel de controle ou no registro de eventos.	<input type="checkbox"/>
M/A	Se o feedback do STO for utilizado, verifique se o STO está ativo verificando o estado do feedback do STO.	<input type="checkbox"/>
M/A	Reaplique a alimentação de 24 V CC nos dois terminais de entrada de STO.	<input type="checkbox"/>
M/-	Verifique se o motor permanece no estado de parada por inércia e se todos os relés conectados permanecem ativados.	<input type="checkbox"/>
M/-	Envie um sinal de reset via fieldbus, E/S digital ou painel de controle.	<input type="checkbox"/>
M/A	Verifique se o motor dá partida e funciona dentro da faixa de velocidade original.	<input type="checkbox"/>

1.7 Perdas de energia e eficiência

Para obter dados de perda de energia, incluindo perdas de carga parcial, consulte <https://ecosmart.mydrive.danfoss.com>.

Illustrations / Abbildungen / Illustrations / Illustrazioni / 图解 /
 Ilustraciones / Ilustrações

1 FA02-FA08/FK02-FK08

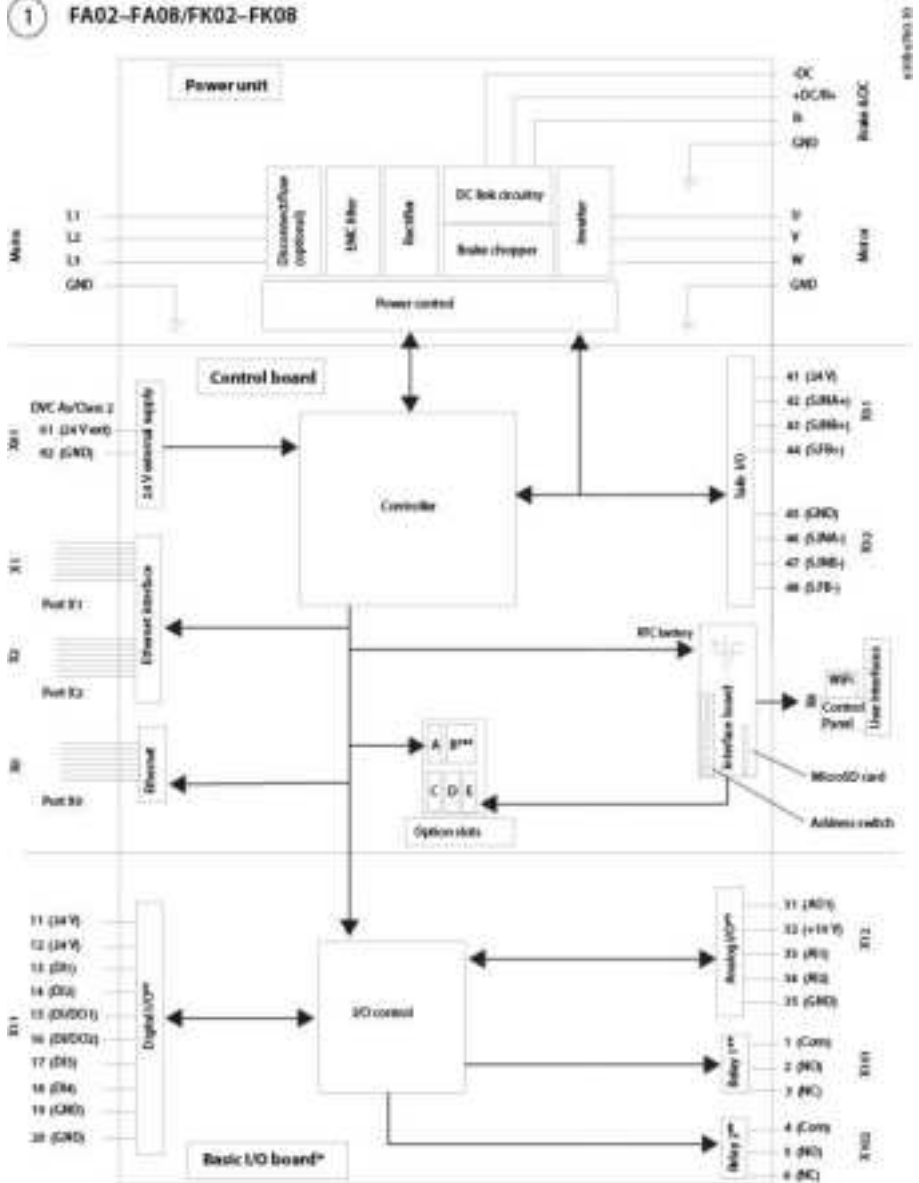

* Optional. ** Functionality set by parameters. *** Option B is available only in FA02-FA08/FK02-FK08.





2 FA02-FA08/FK02-FK08

e10044-100_1.0

		 REC	 UL	 Type 1 L (mm FT)
05-01A3	FA02	10 A, gG	3 A, RK5	52 (1.8)
05-01A8	FA02	10 A, gG	6 A, RK5	52 (1.8)
05-02A4	FA02	10 A, gG	6 A, RK5	52 (1.8)
05-03A0	FA02	10 A, gG	10 A, RK5	52 (1.8)
05-04A0	FA02	10 A, gG	10 A, RK5	52 (1.8)
05-05A6	FA02	10 A, gG	10 A, RK5	52 (1.8)
05-07A2	FA02	10 A, gG	15 A, RK5	52 (1.8)
05-09A2	FA02	16 A, gG	15 A, RK5	52 (1.8)
05-12A5	FA02	20 A, gG	20 A, RK5	52 (1.8)
05-16A0	FA03	25 A, gG	25 A, RK5	52 (1.8)
05-24A0	FA04	40 A, gG	40 A, RK5	96 (3.4)
05-31A0	FA04	50 A, gG	50 A, RK5	96 (3.4)
05-38A0	FA05	50 A, gG	60 A, RK5	96 (3.4)
05-43A0	FA05	63 A, gG	70 A, RK5	96 (3.4)
05-61A0	FA06	80 A, gG	80 A, RK5	192 (6.0)
05-61A0	FK06	80 A, gG	80 A, T/J	-
05-73A0	FA06	100 A, gG	100 A, T/J	192 (6.0)
05-73A0	FK06	100 A, gG	100 A, T/J	-
05-90A0	FA07	125 A, gG	125 A, T/J	340 (8.5)
05-90A0	FK07	125 A, gG	125 A, T/J	-
05-106A	FA07	160 A, gG	150 A, T/J	340 (8.5)
05-106A	FK07	160 A, gG	150 A, T/J	-
05-147A	FA08	200 A, gG	200 A, T/J	288 (10.2)
05-147A	FK08	200 A, gG	200 A, T/J	-
05-170A	FA08	224 A, gG	225 A, T/J	288 (10.2)
05-170A	FK08	224 A, gG	225 A, T/J	-

3 FA02-FA08/FK02-FK08

v0304008.1.1

	L1/L2/L3 (U/V/W)		-DC R, +DC/R+	
	 [mm ² (AWG)]	 [mm (Ø)]	 [mm ² (AWG)]	 [mm (Ø)]
05-01A3 FA02	1,5-4 (16-12)	10 (0,4)	1,5-4 (16-12)	10 (0,4)
05-01A8 FA02	1,5-4 (16-12)	10 (0,4)	1,5-4 (16-12)	10 (0,4)
05-02A4 FA02	1,5-4 (16-12)	10 (0,4)	1,5-4 (16-12)	10 (0,4)
05-03A0 FA02	1,5-4 (16-12)	10 (0,4)	1,5-4 (16-12)	10 (0,4)
05-04A0 FA02	1,5-4 (16-12)	10 (0,4)	1,5-4 (16-12)	10 (0,4)
05-05A6 FA02	1,5-4 (16-12)	10 (0,4)	1,5-4 (16-12)	10 (0,4)
05-07A2 FA02	1,5-4 (16-12)	10 (0,4)	1,5-4 (16-12)	10 (0,4)
05-09A2 FA02	4-6 (12-10)	10 (0,4)	4-6 (12-10)	10 (0,4)
05-12A5 FA02	4-6 (12-10)	10 (0,4)	4-6 (12-10)	10 (0,4)
05-16A0 FA03	4-6 (12-10)	10 (0,4)	4-6 (12-10)	10 (0,4)
05-24A0 FA04	6-16 (10-6)	15 (0,6)	6-16 (10-6)	15 (0,6)
05-31A0 FA04	6-16 (10-6)	15 (0,6)	6-16 (10-6)	15 (0,6)
05-38A0 FA05	10-25 (8-4)	22 (0,9)	10-25 (8-4)	22 (0,9)
05-43A0 FA05	10-25 (8-4)	22 (0,9)	10-25 (8-4)	22 (0,9)
05-61A0 FA06	16-50 (6-1)	17 (0,7)	16-50 (6-1)	17 (0,7)
05-61A0 FK06	16-50 (6-1)	17 (0,7)	16-50 (6-1)	17 (0,7)
05-73A0 FA06	16-50 (6-1)	17 (0,7)	16-50 (6-1)	17 (0,7)
05-73A0 FK06	16-50 (6-1)	17 (0,7)	16-50 (6-1)	17 (0,7)
05-90A0 FA07	35-95 (2-3/0)	22 (0,9)	35-95 (2-3/0)	22 (0,9)
05-90A0 FK07	35-95 (2-3/0)	22 (0,9)	35-95 (2-3/0)	22 (0,9)
05-106A FA07	35-95 (2-3/0)	22 (0,9)	35-95 (2-3/0)	22 (0,9)
05-106A FK07	35-95 (2-3/0)	22 (0,9)	35-95 (2-3/0)	22 (0,9)
05-147A FA08	50-120 (1-3/00 mm)	29 (1,1)	35-95 (2-3/0)	22 (0,9)
05-147A FK08	50-120 (1-4/0)	29 (1,1)	35-95 (2-3/0)	22 (0,9)
05-170A FA08	50-150 (1-3/00 mm)	29 (1,1)	35-95 (2-3/0)	22 (0,9)
05-170A FK08	50-120 (1-4/0)	29 (1,1)	35-95 (2-3/0)	22 (0,9)

4 FA02-FA05

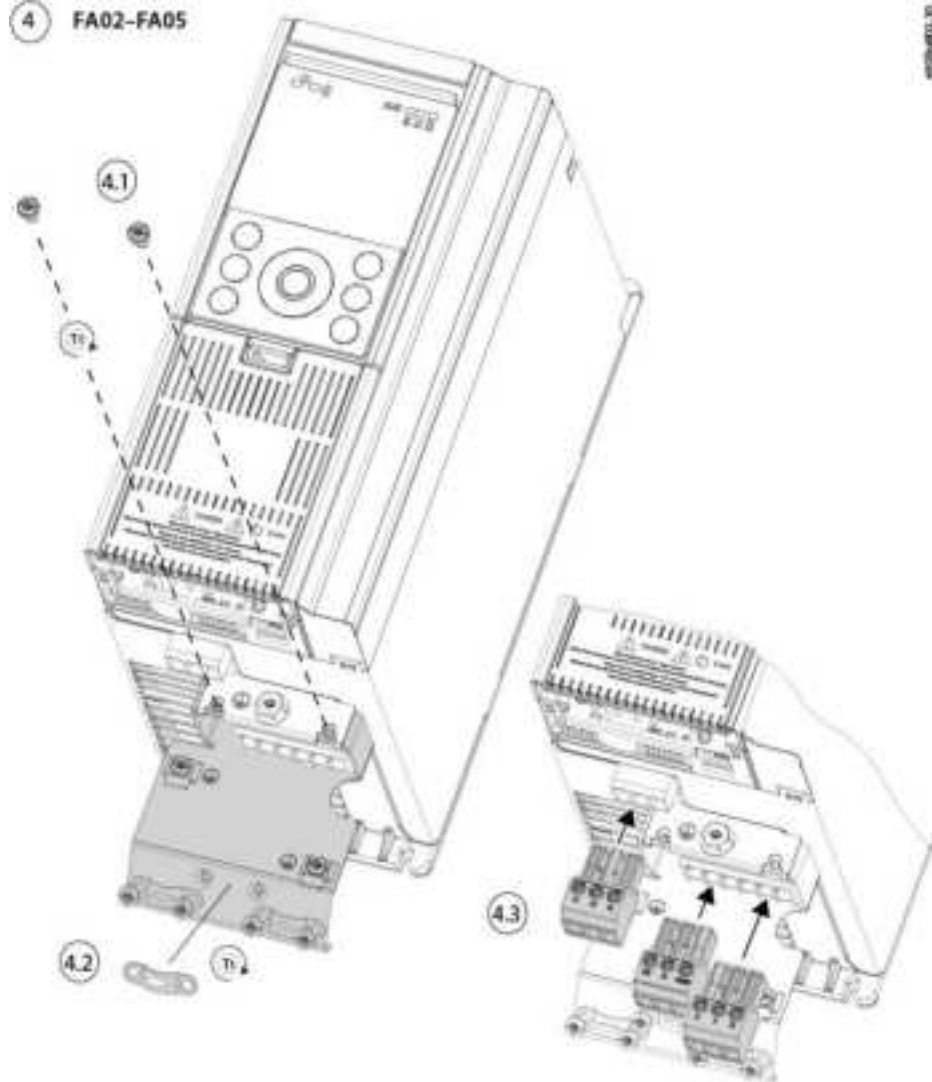

$T_1 = 12 \text{ Nm}$ (18 in-lb)

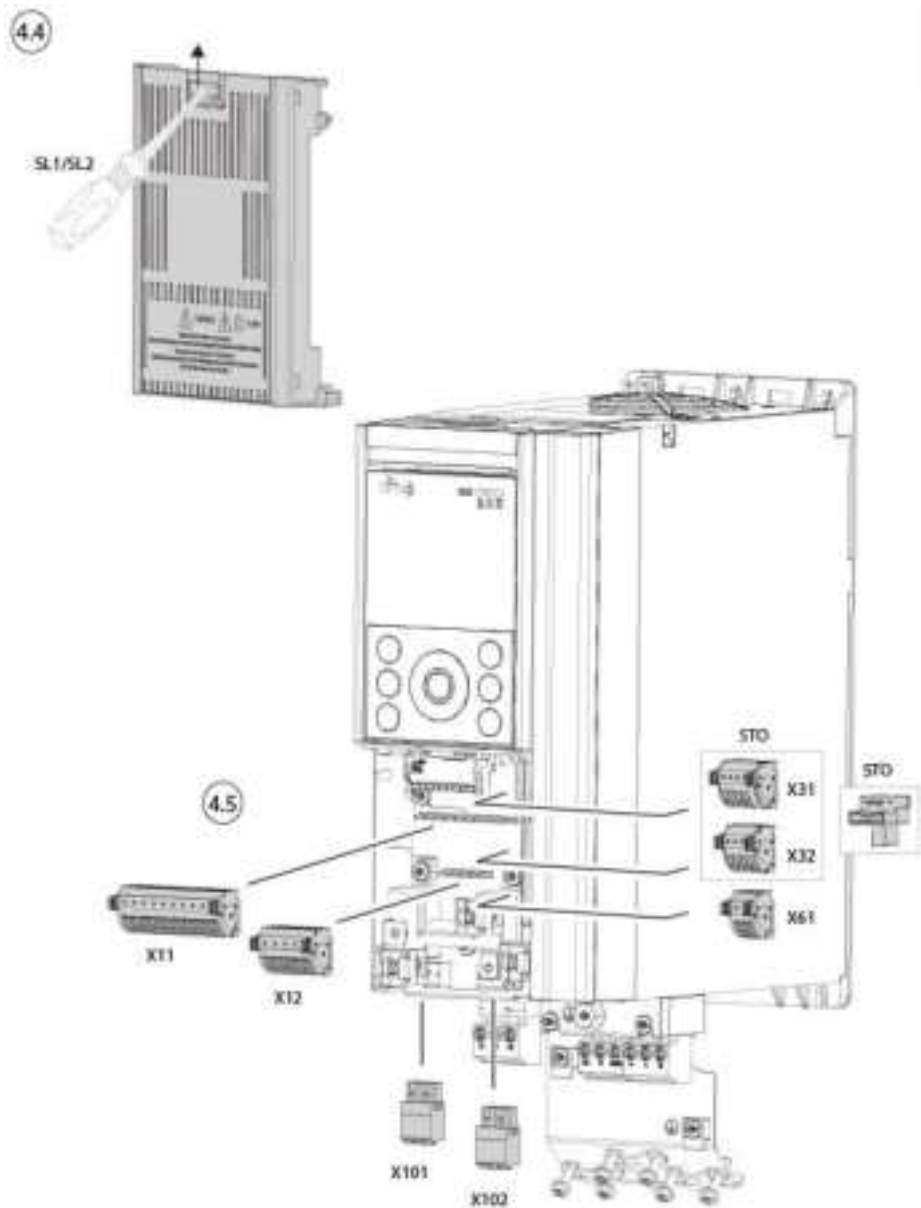

FA06-FA07

400079611

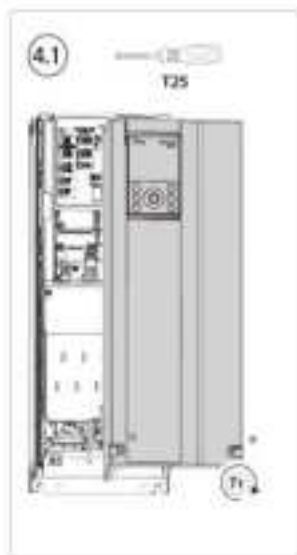

T1 = 0.5 Nm (31 in-lb)

T2 = 2 Nm (18 in-lb)

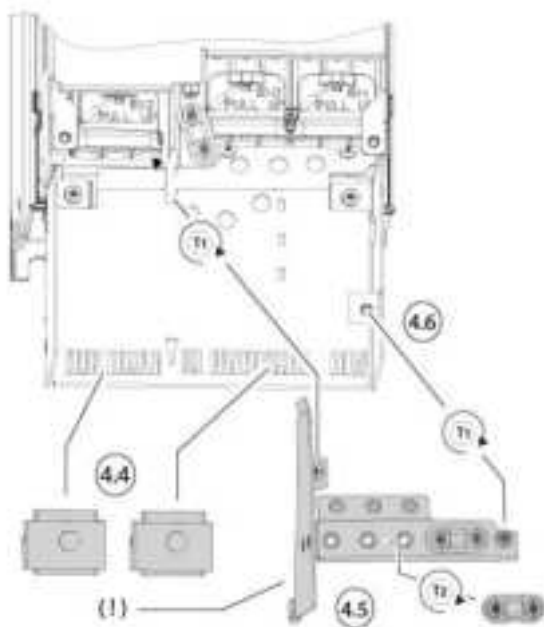
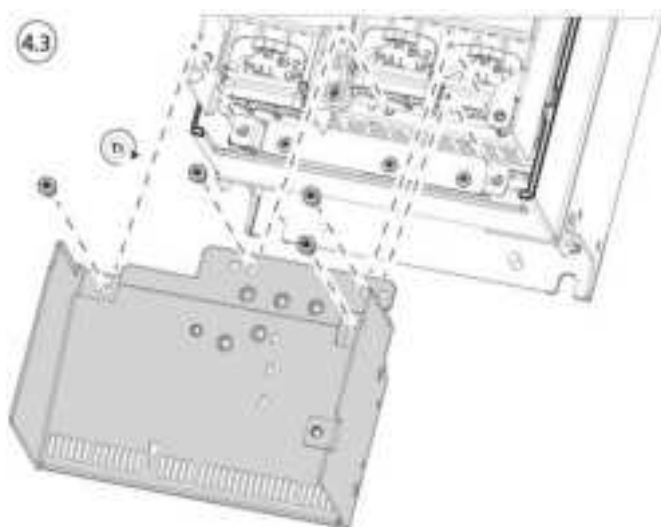

T1 - [3.5 Nm (31 in-lb)]

T2 - [2 Nm (18 in-lb)]

FA08

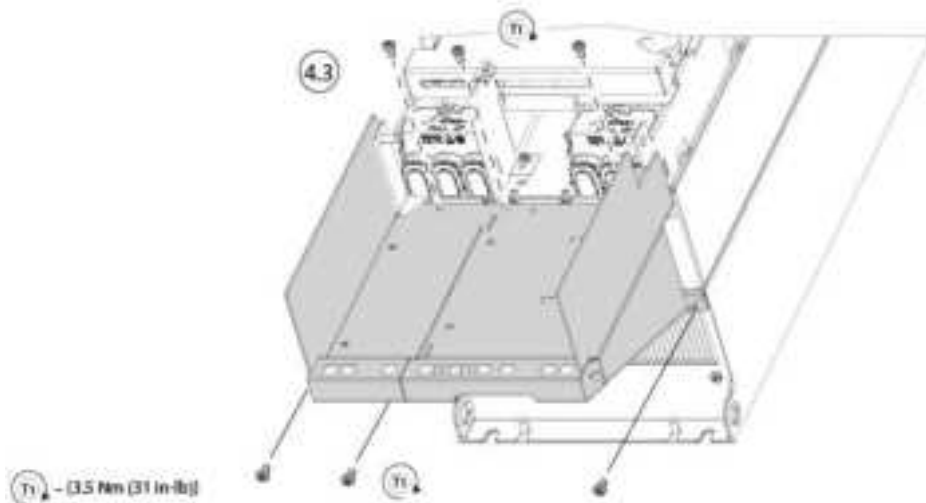
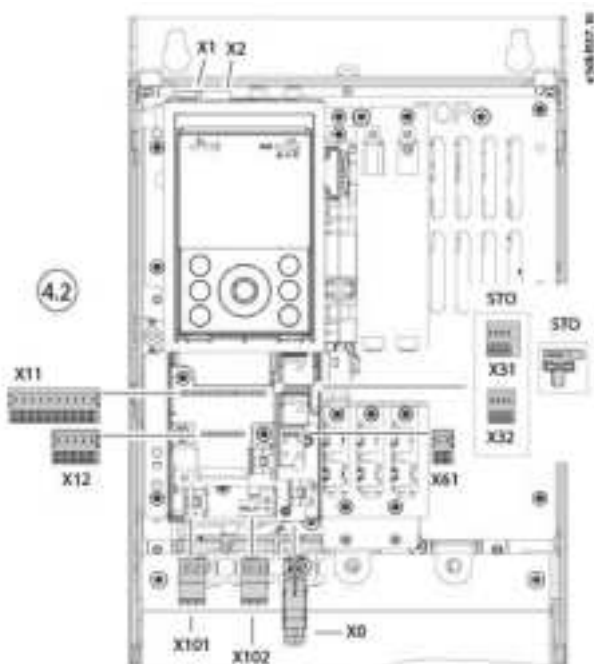
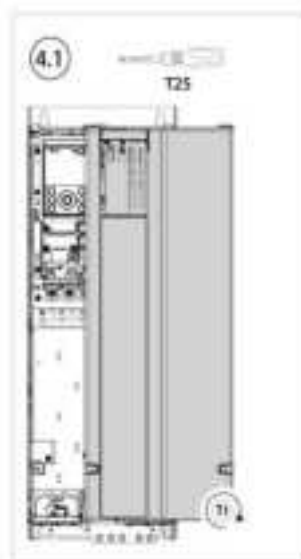

FK06-FK07

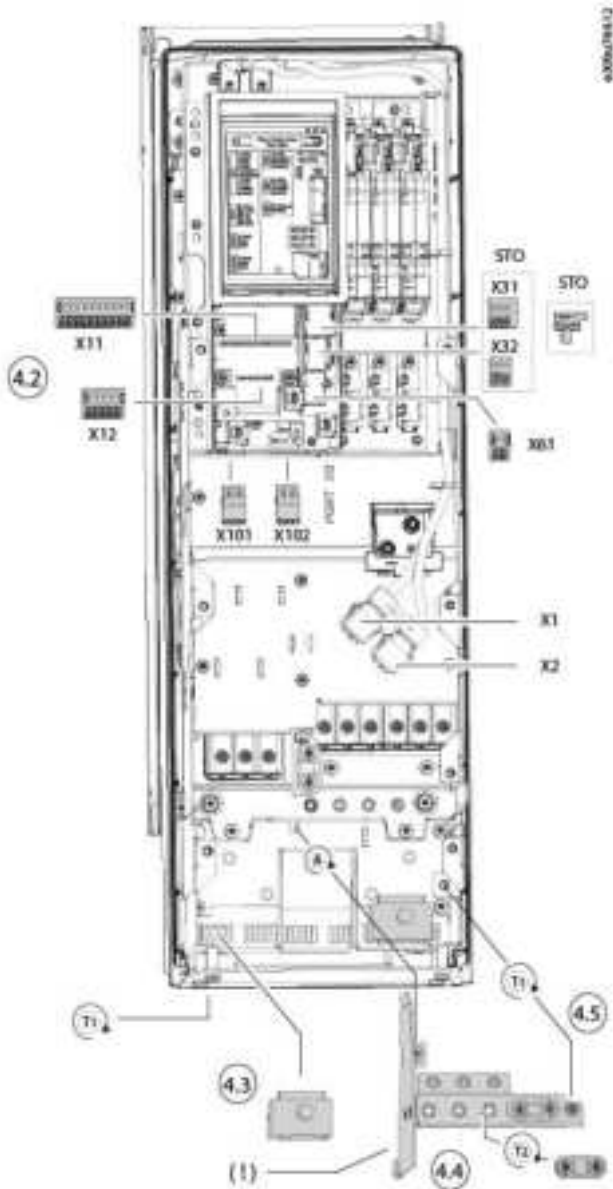
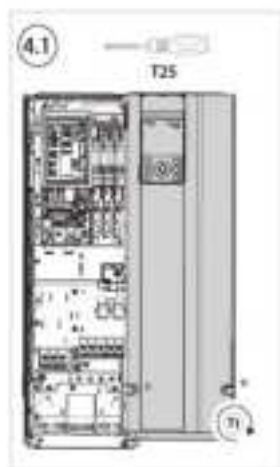

- T1 - [3.5 Nm (31 in-lb)]
- T2 - [2 Nm (18 in-lb)]

FK08

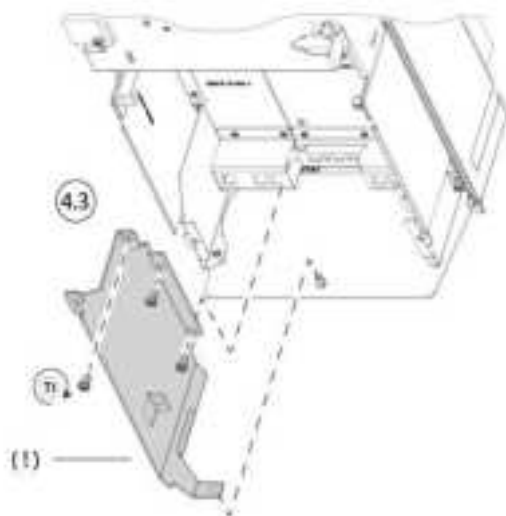
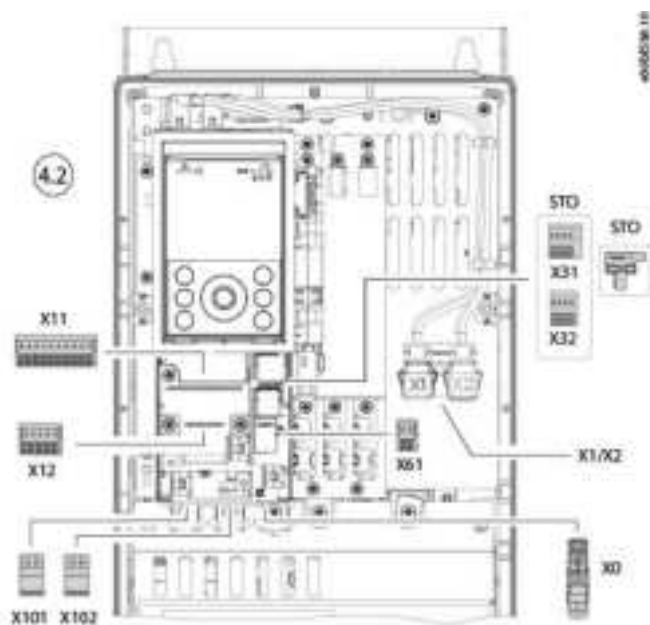
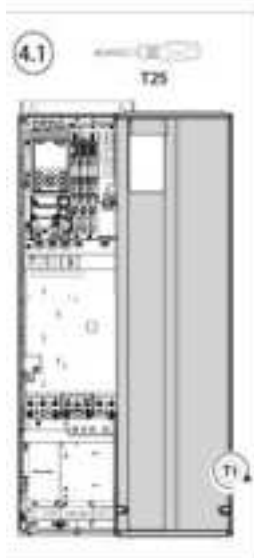

11 – (3.5 Nm (31 in-lb))

4.4

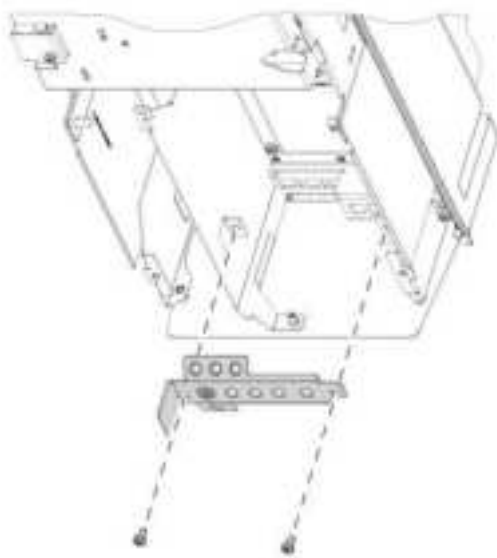

www.danfoss.com

4.5

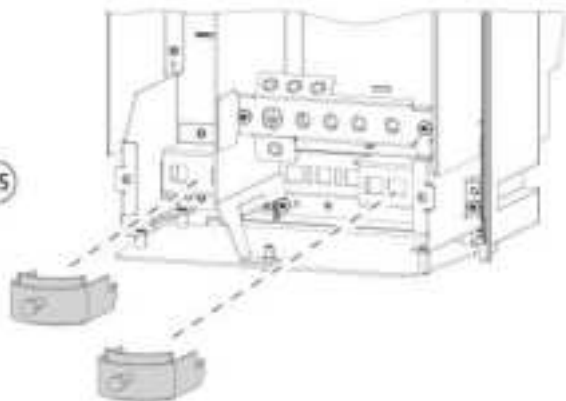

5 FA02-FA08/FK02-FK08

[mm (in)]	FA02	FA03	FA04	FA05	FA06/FK06	FA07/FK07	FA08/FK08
A	257 (10.1)	257 (10.1)	360 (15.0)	360 (15.0)	535 (21.1)	580 (22.1)	721 (28.4)
B	70 (2.8)	94 (3.7)	105 (4.1)	140 (5.5)	170 (6.7)	200 (7.9)	200 (7.9)
C	100 (3.9)	100 (3.9)	100 (3.9)	100 (3.9)	200 (7.9)	200 (7.9)	200 (7.9)
	4 x M5		4 x M6		4 x M8		

en/Manual/FC0-38

5.1



5.2



5.3

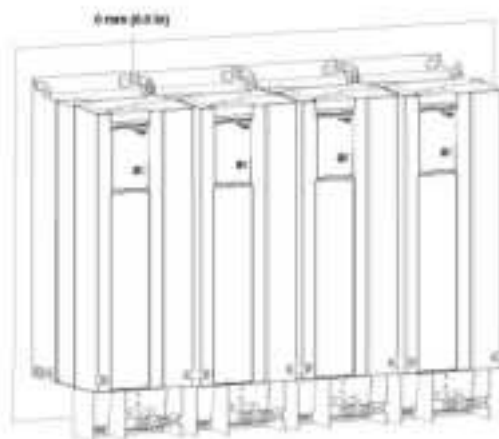

6 FK06-FK08

1000000111

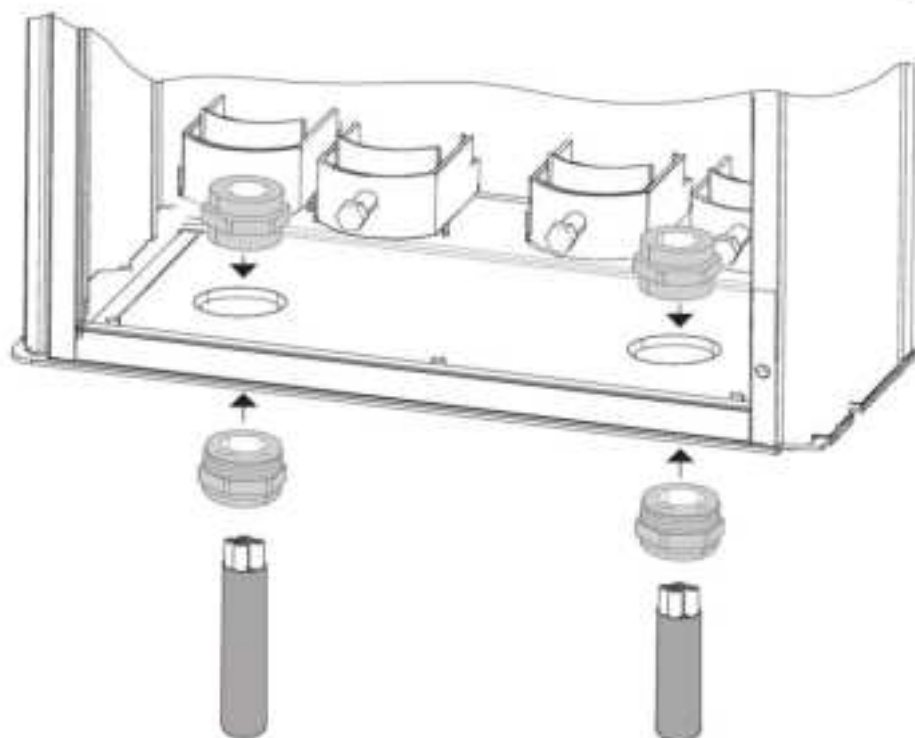

7 FA02-FA08/FK02-FK08

438624122

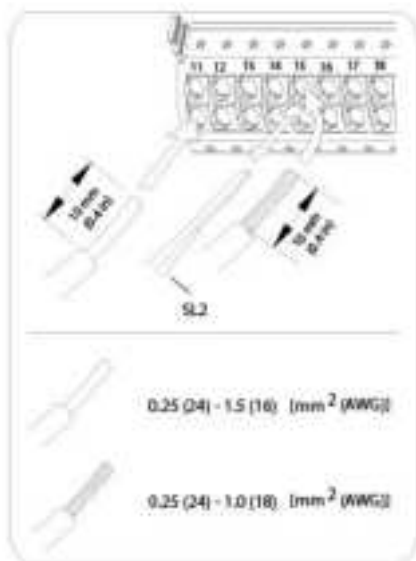
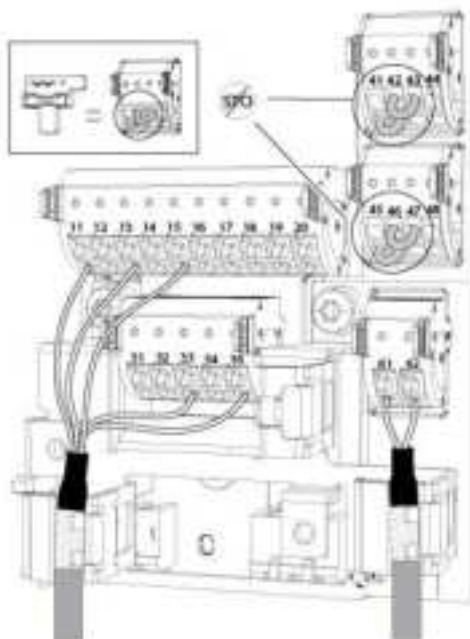
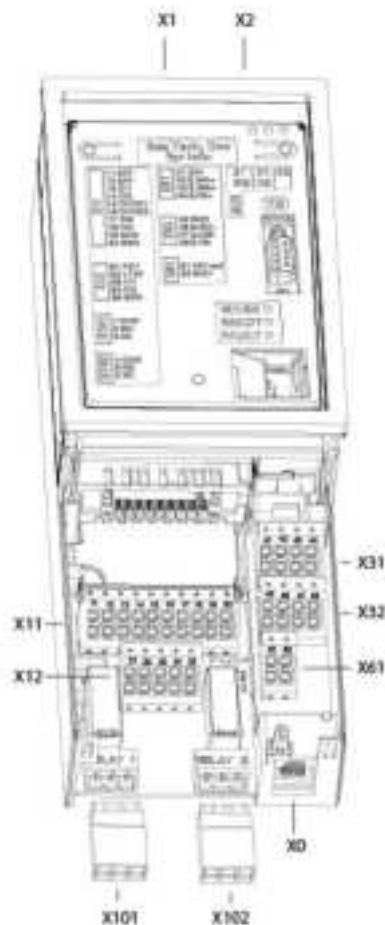

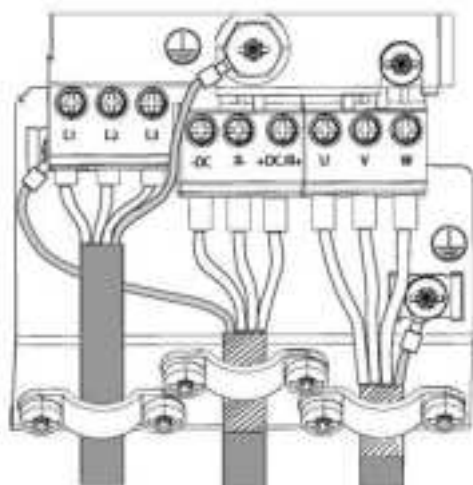
8 FA02-FA03

FA02	L1, L2, L3	0.7 Nm (5 in-lb)
FA03	U, V, W	0.7 Nm (5 in-lb)
	-DC, R, +DC, R+	0.7 Nm (5 in-lb)
FA04	L1, L2, L3	1.2-1.5 Nm (11-13 in-lb)
	U, V, W	1.2-1.5 Nm (11-13 in-lb)
	-DC, R, +DC, R+	1.2-1.5 Nm (11-13 in-lb)
FA05	L1, L2, L3	2.0-2.5 Nm (18-22 in-lb)
	U, V, W	2.0-2.5 Nm (18-22 in-lb)
	-DC, R, +DC, R+	2.0-2.5 Nm (18-22 in-lb)
	⊕	3 Nm (26 in-lb)
FA02-FA03 SL1/PZ1		
FA04 SL1/T15 		
FA05 SL2/T20 		

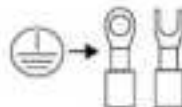
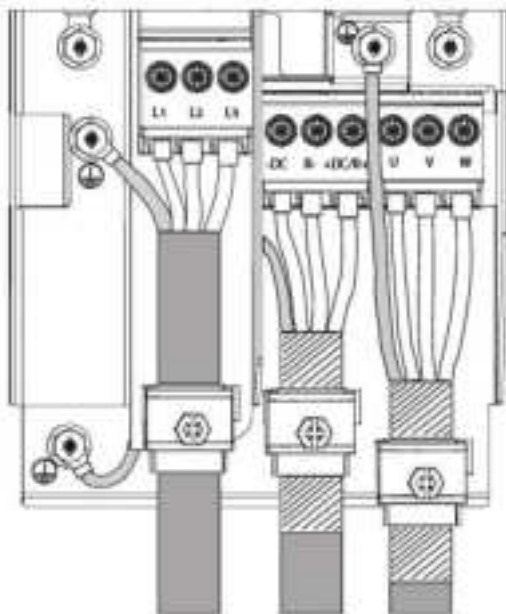
FA04-FA05

FA06-FA07

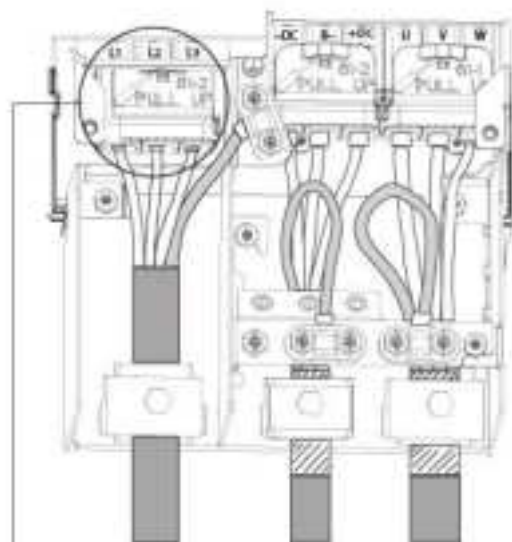

FA06	L1, L2, L3	14 Nm (124 in-lb)
	U, V, W	14 Nm (124 in-lb)
	DC, R-, +DC/R+	14 Nm (124 in-lb)
FA07	L1, L2, L3	14 Nm (124 in-lb)
	U, V, W	14 Nm (124 in-lb)
	-DC, R-, +DC/R+	14 Nm (124 in-lb)
		2 Nm (8 in-lb)

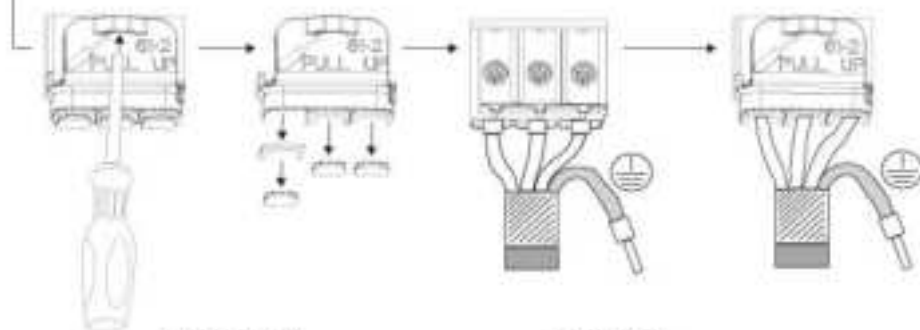

L1, L2, L3 / U, V, W

-DC, R-, +DC/R+

FA06	50 mm ² (1 AWG)	16 mm ² (6 AWG)	FA06	50 mm ² (1 AWG)	16 mm ² (6 AWG)
FA07	95 mm ² (3/0 AWG)	35 mm ² (2 AWG)	FA07	50 mm ² (1 AWG)	16 mm ² (6 AWG)

FA08

4000034143

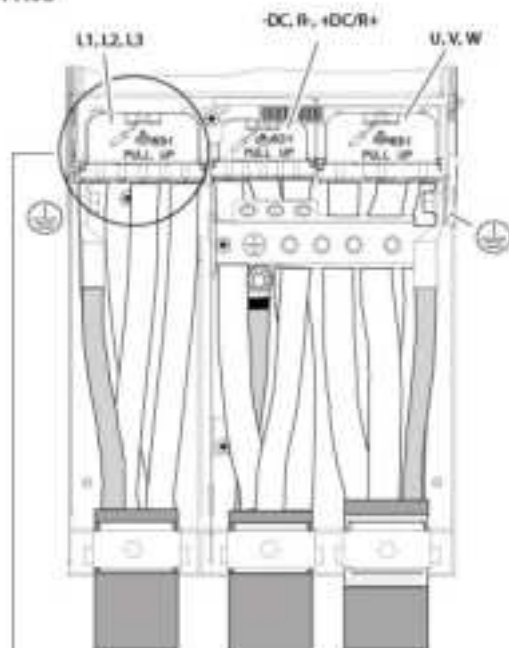

FA08	L1, L2, L3	20 Nm (177 in-lb)
	U, V, W	20 Nm (177 in-lb)
	-DC, R, +DC/R+	14 Nm (124 in-lb)
		12 Nm (106 in-lb)

T30		
T40		
T50		

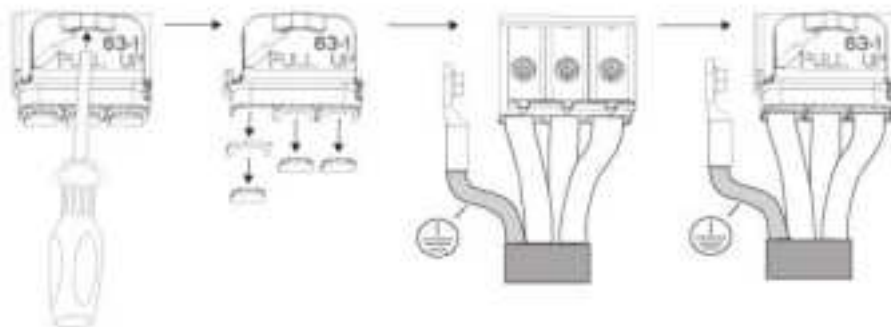

L1, L2, L3 / U, V, W

FA08	150 mm ² (1 AWG)	50 mm ² (1 AWG)

-DC, R, +DC/R+

FA08	95 mm ² (3/0 mcm)	35 mm ² (2 AWG)

FK06–FK07

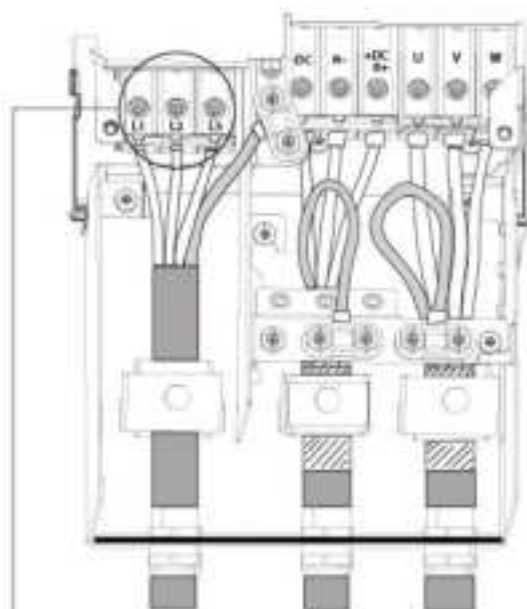

	L1, L2, L3	14 Nm (124 in-lb)
FK06	U, V, W	14 Nm (124 in-lb)
	-DC, R, +DC/R+	14 Nm (124 in-lb)
	L1, L2, L3	14 Nm (124 in-lb)
FK07	U, V, W	14 Nm (124 in-lb)
	-DC, R, +DC/R+	14 Nm (124 in-lb)
		2 Nm (8 in-lb)

T30

10 mm

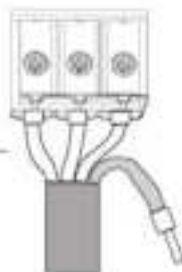

L1, L2, L3 / U, V, W

FK06	50 mm ² (1 AWG)	16 mm ² (6 AWG)
FK07	95 mm ² (3/0 AWG)	35 mm ² (2 AWG)

-DC, R, +DC/R+

FK06	50 mm ² (1 AWG)	16 mm ² (6 AWG)
FK07	50 mm ² (1 AWG)	16 mm ² (6 AWG)

FK08

a1010543116

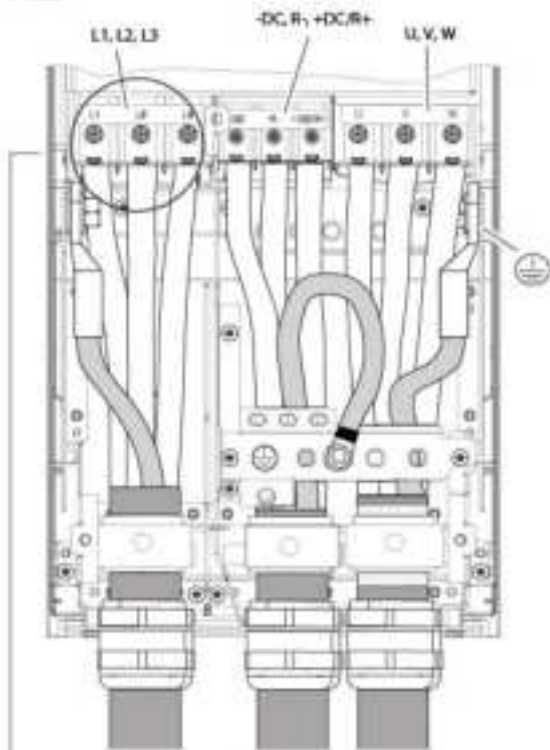

FK08	L1, L2, L3	20 Nm (177 in-lb)
	U, V, W	20 Nm (177 in-lb)
	-DC, R-, +DC/R+	14 Nm (124 in-lb)
		12 Nm (106 in-lb)
	T30	10 mm
	T40	
	T50	

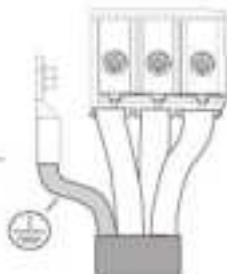

L1, L2, L3 / U, V, W

FK08 120 mm² (4/0 mcm) 50 mm² (1 AWG)

-DC, R-, +DC/R+

FK08 95 mm² (3/0 AWG) 35 mm² (2 AWG)

9 FA06-FA08/FK06-FK08

4305678111

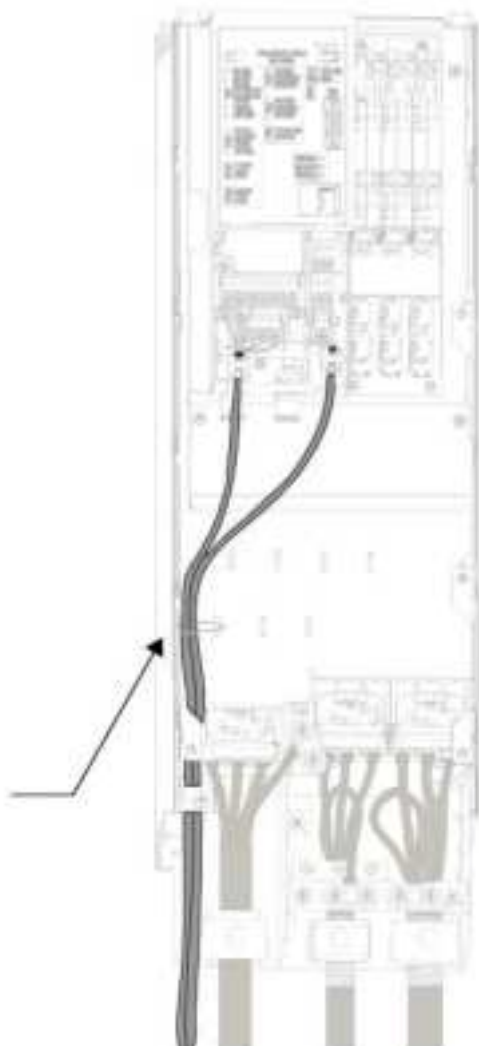

Indirizzo Danfoss di riferimento: Danfoss S.p.A. - Via S. Felice 10 - 20139 Milano - Italia



Danfoss A/S
 Via S. Felice 10
 20139 Milano - Italia
 Tel. +39 02 76061111
 Fax +39 02 76061112

EU DECLARATION OF CONFORMITY

Danfoss A/S
 Danfoss Italia

Il presente oggetto è conforme ai requisiti della

Prodotto e progettato da Danfoss A/S

Modello designato: A/S 110/120/130/140/150/160/170/180/190/200/210/220/230/240/250/260/270/280/290/300/310/320/330/340/350/360/370/380/390/400/410/420/430/440/450/460/470/480/490/500/510/520/530/540/550/560/570/580/590/600/610/620/630/640/650/660/670/680/690/700/710/720/730/740/750/760/770/780/790/800/810/820/830/840/850/860/870/880/890/900/910/920/930/940/950/960/970/980/990/1000/1010/1020/1030/1040/1050/1060/1070/1080/1090/1100/1110/1120/1130/1140/1150/1160/1170/1180/1190/1200/1210/1220/1230/1240/1250/1260/1270/1280/1290/1300/1310/1320/1330/1340/1350/1360/1370/1380/1390/1400/1410/1420/1430/1440/1450/1460/1470/1480/1490/1500/1510/1520/1530/1540/1550/1560/1570/1580/1590/1600/1610/1620/1630/1640/1650/1660/1670/1680/1690/1700/1710/1720/1730/1740/1750/1760/1770/1780/1790/1800/1810/1820/1830/1840/1850/1860/1870/1880/1890/1900/1910/1920/1930/1940/1950/1960/1970/1980/1990/2000/2010/2020/2030/2040/2050/2060/2070/2080/2090/2100/2110/2120/2130/2140/2150/2160/2170/2180/2190/2200/2210/2220/2230/2240/2250/2260/2270/2280/2290/2300/2310/2320/2330/2340/2350/2360/2370/2380/2390/2400/2410/2420/2430/2440/2450/2460/2470/2480/2490/2500/2510/2520/2530/2540/2550/2560/2570/2580/2590/2600/2610/2620/2630/2640/2650/2660/2670/2680/2690/2700/2710/2720/2730/2740/2750/2760/2770/2780/2790/2800/2810/2820/2830/2840/2850/2860/2870/2880/2890/2900/2910/2920/2930/2940/2950/2960/2970/2980/2990/3000/3010/3020/3030/3040/3050/3060/3070/3080/3090/3100/3110/3120/3130/3140/3150/3160/3170/3180/3190/3200/3210/3220/3230/3240/3250/3260/3270/3280/3290/3300/3310/3320/3330/3340/3350/3360/3370/3380/3390/3400/3410/3420/3430/3440/3450/3460/3470/3480/3490/3500/3510/3520/3530/3540/3550/3560/3570/3580/3590/3600/3610/3620/3630/3640/3650/3660/3670/3680/3690/3700/3710/3720/3730/3740/3750/3760/3770/3780/3790/3800/3810/3820/3830/3840/3850/3860/3870/3880/3890/3900/3910/3920/3930/3940/3950/3960/3970/3980/3990/4000/4010/4020/4030/4040/4050/4060/4070/4080/4090/4100/4110/4120/4130/4140/4150/4160/4170/4180/4190/4200/4210/4220/4230/4240/4250/4260/4270/4280/4290/4300/4310/4320/4330/4340/4350/4360/4370/4380/4390/4400/4410/4420/4430/4440/4450/4460/4470/4480/4490/4500/4510/4520/4530/4540/4550/4560/4570/4580/4590/4600/4610/4620/4630/4640/4650/4660/4670/4680/4690/4700/4710/4720/4730/4740/4750/4760/4770/4780/4790/4800/4810/4820/4830/4840/4850/4860/4870/4880/4890/4900/4910/4920/4930/4940/4950/4960/4970/4980/4990/5000/5010/5020/5030/5040/5050/5060/5070/5080/5090/5100/5110/5120/5130/5140/5150/5160/5170/5180/5190/5200/5210/5220/5230/5240/5250/5260/5270/5280/5290/5300/5310/5320/5330/5340/5350/5360/5370/5380/5390/5400/5410/5420/5430/5440/5450/5460/5470/5480/5490/5500/5510/5520/5530/5540/5550/5560/5570/5580/5590/5600/5610/5620/5630/5640/5650/5660/5670/5680/5690/5700/5710/5720/5730/5740/5750/5760/5770/5780/5790/5800/5810/5820/5830/5840/5850/5860/5870/5880/5890/5900/5910/5920/5930/5940/5950/5960/5970/5980/5990/6000/6010/6020/6030/6040/6050/6060/6070/6080/6090/6100/6110/6120/6130/6140/6150/6160/6170/6180/6190/6200/6210/6220/6230/6240/6250/6260/6270/6280/6290/6300/6310/6320/6330/6340/6350/6360/6370/6380/6390/6400/6410/6420/6430/6440/6450/6460/6470/6480/6490/6500/6510/6520/6530/6540/6550/6560/6570/6580/6590/6600/6610/6620/6630/6640/6650/6660/6670/6680/6690/6700/6710/6720/6730/6740/6750/6760/6770/6780/6790/6800/6810/6820/6830/6840/6850/6860/6870/6880/6890/6900/6910/6920/6930/6940/6950/6960/6970/6980/6990/7000/7010/7020/7030/7040/7050/7060/7070/7080/7090/7100/7110/7120/7130/7140/7150/7160/7170/7180/7190/7200/7210/7220/7230/7240/7250/7260/7270/7280/7290/7300/7310/7320/7330/7340/7350/7360/7370/7380/7390/7400/7410/7420/7430/7440/7450/7460/7470/7480/7490/7500/7510/7520/7530/7540/7550/7560/7570/7580/7590/7600/7610/7620/7630/7640/7650/7660/7670/7680/7690/7700/7710/7720/7730/7740/7750/7760/7770/7780/7790/7800/7810/7820/7830/7840/7850/7860/7870/7880/7890/7900/7910/7920/7930/7940/7950/7960/7970/7980/7990/8000/8010/8020/8030/8040/8050/8060/8070/8080/8090/8100/8110/8120/8130/8140/8150/8160/8170/8180/8190/8200/8210/8220/8230/8240/8250/8260/8270/8280/8290/8300/8310/8320/8330/8340/8350/8360/8370/8380/8390/8400/8410/8420/8430/8440/8450/8460/8470/8480/8490/8500/8510/8520/8530/8540/8550/8560/8570/8580/8590/8600/8610/8620/8630/8640/8650/8660/8670/8680/8690/8700/8710/8720/8730/8740/8750/8760/8770/8780/8790/8800/8810/8820/8830/8840/8850/8860/8870/8880/8890/8900/8910/8920/8930/8940/8950/8960/8970/8980/8990/9000/9010/9020/9030/9040/9050/9060/9070/9080/9090/9100/9110/9120/9130/9140/9150/9160/9170/9180/9190/9200/9210/9220/9230/9240/9250/9260/9270/9280/9290/9300/9310/9320/9330/9340/9350/9360/9370/9380/9390/9400/9410/9420/9430/9440/9450/9460/9470/9480/9490/9500/9510/9520/9530/9540/9550/9560/9570/9580/9590/9600/9610/9620/9630/9640/9650/9660/9670/9680/9690/9700/9710/9720/9730/9740/9750/9760/9770/9780/9790/9800/9810/9820/9830/9840/9850/9860/9870/9880/9890/9900/9910/9920/9930/9940/9950/9960/9970/9980/9990/10000/10001/10002/10003/10004/10005/10006/10007/10008/10009/10010/10011/10012/10013/10014/10015/10016/10017/10018/10019/10020/10021/10022/10023/10024/10025/10026/10027/10028/10029/10030/10031/10032/10033/10034/10035/10036/10037/10038/10039/10040/10041/10042/10043/10044/10045/10046/10047/10048/10049/10050/10051/10052/10053/10054/10055/10056/10057/10058/10059/10060/10061/10062/10063/10064/10065/10066/10067/10068/10069/10070/10071/10072/10073/10074/10075/10076/10077/10078/10079/10080/10081/10082/10083/10084/10085/10086/10087/10088/10089/10090/10091/10092/10093/10094/10095/10096/10097/10098/10099/10100/10101/10102/10103/10104/10105/10106/10107/10108/10109/10110/10111/10112/10113/10114/10115/10116/10117/10118/10119/10120/10121/10122/10123/10124/10125/10126/10127/10128/10129/10130/10131/10132/10133/10134/10135/10136/10137/10138/10139/10140/10141/10142/10143/10144/10145/10146/10147/10148/10149/10150/10151/10152/10153/10154/10155/10156/10157/10158/10159/10160/10161/10162/10163/10164/10165/10166/10167/10168/10169/10170/10171/10172/10173/10174/10175/10176/10177/10178/10179/10180/10181/10182/10183/10184/10185/10186/10187/10188/10189/10190/10191/10192/10193/10194/10195/10196/10197/10198/10199/10200/10201/10202/10203/10204/10205/10206/10207/10208/10209/10210/10211/10212/10213/10214/10215/10216/10217/10218/10219/10220/10221/10222/10223/10224/10225/10226/10227/10228/10229/10230/10231/10232/10233/10234/10235/10236/10237/10238/10239/10240/10241/10242/10243/10244/10245/10246/10247/10248/10249/10250/10251/10252/10253/10254/10255/10256/10257/10258/10259/10260/10261/10262/10263/10264/10265/10266/10267/10268/10269/10270/10271/10272/10273/10274/10275/10276/10277/10278/10279/10280/10281/10282/10283/10284/10285/10286/10287/10288/10289/10290/10291/10292/10293/10294/10295/10296/10297/10298/10299/10300/10301/10302/10303/10304/10305/10306/10307/10308/10309/10310/10311/10312/10313/10314/10315/10316/10317/10318/10319/10320/10321/10322/10323/10324/10325/10326/10327/10328/10329/10330/10331/10332/10333/10334/10335/10336/10337/10338/10339/10340/10341/10342/10343/10344/10345/10346/10347/10348/10349/10350/10351/10352/10353/10354/10355/10356/10357/10358/10359/10360/10361/10362/10363/10364/10365/10366/10367/10368/10369/10370/10371/10372/10373/10374/10375/10376/10377/10378/10379/10380/10381/10382/10383/10384/10385/10386/10387/10388/10389/10390/10391/10392/10393/10394/10395/10396/10397/10398/10399/10400/10401/10402/10403/10404/10405/10406/10407/10408/10409/10410/10411/10412/10413/10414/10415/10416/10417/10418/10419/10420/10421/10422/10423/10424/10425/10426/10427/10428/10429/10430/10431/10432/10433/10434/10435/10436/10437/10438/10439/10440/10441/10442/10443/10444/10445/10446/10447/10448/10449/10450/10451/10452/10453/10454/10455/10456/10457/10458/10459/10460/10461/10462/10463/10464/10465/10466/10467/10468/10469/10470/10471/10472/10473/10474/10475/10476/10477/10478/10479/10480/10481/10482/10483/10484/10485/10486/10487/10488/10489/10490/10491/10492/10493/10494/10495/10496/10497/10498/10499/10500/10501/10502/10503/10504/10505/10506/10507/10508/10509/10510/10511/10512/10513/10514/10515/10516/10517/10518/10519/10520/10521/10522/10523/10524/10525/10526/10527/10528/10529/10530/10531/10532/10533/10534/10535/10536/10537/10538/10539/10540/10541/10542/10543/10544/10545/10546/10547/10548/10549/10550/10551/10552/10553/10554/10555/10556/10557/10558/10559/10560/10561/10562/10563/10564/10565/10566/10567/10568/10569/10570/10571/10572/10573/10574/10575/10576/10577/10578/10579/10580/10581/10582/10583/10584/10585/10586/10587/10588/10589/10590/10591/10592/10593/10594/10595/10596/10597/10598/10599/10600/10601/10602/10603/10604/10605/10606/10607/10608/10609/10610/10611/10612/10613/10614/10615/10616/10617/10618/10619/10620/10621/10622/10623/10624/10625/10626/10627/10628/10629/10630/10631/10632/10633/10634/10635/10636/10637/10638/10639/10640/10641/10642/10643/10644/10645/10646/10647/10648/10649/10650/10651/10652/10653/10654/10655/10656/10657/10658/10659/10660/10661/10662/10663/10664/10665/10666/10667/10668/10669/10670/10671/10672/10673/10674/10675/10676/10677/10678/10679/10680/10681/10682/10683/10684/10685/10686/10687/10688/10689/10690/10691/10692/10693/10694/10695/10696/10697/10698/10699/10700/10701/10702/10703/10704/10705/10706/10707/10708/10709/10710/10711/10712/10713/10714/10715/10716/10717/10718/10719/10720/10721/10722/10723/10724/10725/10726/10727/10728/10729/10730/10731/10732/10733/10734/10735/10736/10737/10738/10739/10740/10741/10742/10743/10744/10745/10746/10747/10748/10749/10750/10751/10752/10753/10754/10755/10756/10757/10758/10759/10760/10761/10762/10763/10764/10765/10766/10767/10768/10769/10770/10771/10772/10773/10774/10775/10776/10777/10778/10779/10780/10781/10782/10783/10784/10785/10786/10787/10788/10789/10790/10791/10792/10793/10794/10795/10796/10797/10798/10799/10800/10801/10802/10803/10804/10805/10806/10807/10808/10809/10810/10811/10812/10813/10814/10815/10816/10817/10818/10819/10820/10821/10822/10823/10824/10825/10826/10827/10828/10829/10830/10831/10832/10833/10834/10835/10836/10837/10838/10839/10840/10841/10842/10843/10844/10845/10846/10847/10848/10849/10850/10851/10852/10853/10854/10855/10856/10857/10858/10859/10860/10861/10862/10863/10864/10865/10866/10867/10868/10869/10870/10871/10872/10873/10874/10875/10876/10877/10878/10879/10880/10881/10882/10883/10884/10885/10886/10887/10888/10889/10890/10891/10892/10893/10894/10895/10896/10897/10898/10899/10900/10901/10902/10903/10904/10905/10906/10907/10908/10909/10910/10911/10912/10913/10914/10915/10916/10917/10918/10919/10920/10921/10922/10923/10924/10925/10926/10927/10928/10929/10930/10931/10932/10933/10934/10935/10936/10937/10938/10939/10940/10941/10942/10943/10944/10945/10946/10947/10948/10949/10950/10951/10952/10953/10954/10955/10956/10957/10958/10959/10960/10961/10962/10963/10964/10965/10966/10967/10968/10969/10970/10971/10972/10973/10974/10975/10976/10977/10978/10979/10980/10981/10982/10983/10984/10985/10986/10987/10988/10989/10990/10991/10992/10993/10994/10995/10996/10997/10998/10999/11000/11001/11002/11003/11004/11005/11006/11007/11008/11009/11010/11011/11012/11013/11014/11015/11016/11017/11018/11019/11020/11021/11022/11023/11024/11025/11026/11027/11028/11029/11030/11031/11032/11033/11034/11035/11036/11037/11038/11039/11040/11041/11042/11043/11044/11045/11046/11047/11048/11049/11050/11051/11052/11053/11054/11055/11056/11057/11058/11059/11060/11061/11062/11063/11064/11065/11066/11067/11068/11069/11070/11071/11072/11073/11074/11075/11076/11077/11078/11079/11080/11081/11082/11083/11084/11085/11086/11087/11088/11089/11090/11091/11092/11093/11094/11095/11096/11097/11098/11099/11100/11101/11102/11103/11104/11105/11106/11107/11108/11109/11110/11111/11112/11113/11114/11115/11116/11117/11118/11119/11120/11121/11122/11123/11124/11125/11126/11127/11128/11129/11130/11131/11132/11133/11134/11135/11136/11137/11138/11139/11140/11141/11142/11143/11144/11145/11146/11147/11148/11149/11150/11151/11152/11153/11154/11155/11

ENGINEERING
TO MAKE HOW



Danfoss A/S
Ulsnaes 1
DK-6300 Graasten

Any information, including, but not limited to information on selection of product, its application or use, product design, weight, dimensions, capacity or any other technical data in product manuals, catalog descriptions, advertisements, etc. and whether made available in writing, orally, electronically, online or via download, shall be considered informative, and is only binding if and to the extent, explicit reference is made in a quotation or order confirmation. Danfoss cannot accept any responsibility for possible errors in catalogs, brochures, videos and other material. Danfoss reserves the right to alter its products without notice. This also applies to products ordered but not delivered provided that such alterations can be made without changes to form, fit or function of the product. All trademarks in this material are property of Danfoss A/S or Danfoss group companies. Danfoss and the Danfoss logo are trademarks of Danfoss A/S. All rights reserved.

M00293

Danfoss NS © 2024.05



AN31974005764101-000501 / 136R0242