

Installation guide

Ejector Controller | 080G5022

Type EKE 80



080R9502

080R9502

Introduction

The EKE 80 Ejector Controller receive inputs signals from the Danfoss controllers AK-PC 782A/AK-PC 782B or a PLC.

It can control multiple HP/LP ejectors and up to 2 modulating control valves to facilitate the 'lift' of the MT suction pressure and thereby decreasing energy consumption.

The EKE 80 drive controller is suitable for both new and retrofit systems.



More info

Identification

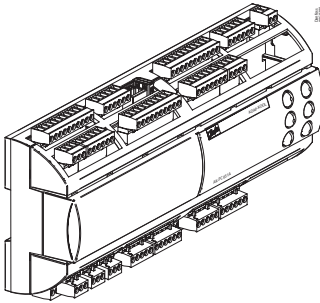

21–265 V AC 50/60 Hz
 CE: -20 – +60 °C, UL: 0 – 50 °C
 (CE: 0 – 140 °F, UL: 32 – 122 °F)
 RH max. 90% non condensing

Application example

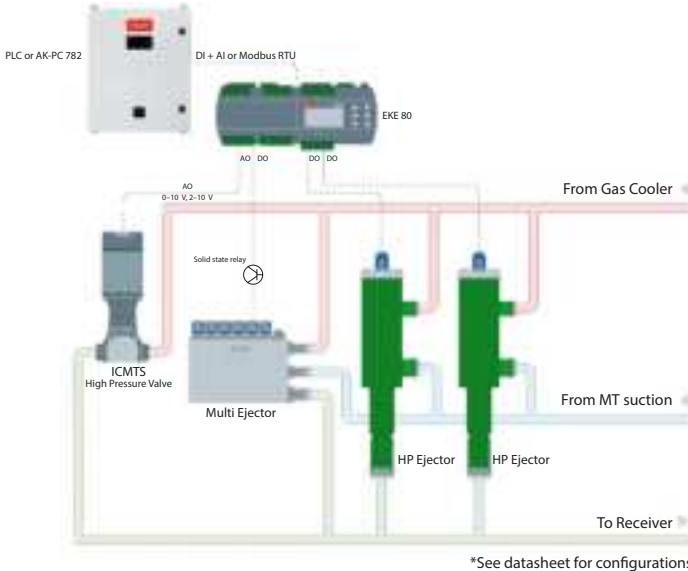

Імпортер: ТОВ з іл "Данфосс ТОВ" 04080, Київ 80, п/с 168, Україна

Info for UK customers only: Danfoss Ltd., 22 Wycombe End, HP9 1NB, GB



General features and warnings

Plastic housing features

- DIN rail mounting complying with EN 60715
- Self extinguishing V0 according to IEC 60695-11-10 and glowing/hot wire test at 960 °C according to IEC 60695-2-12
- Ball test: 125 °C according to IEC 60730-1. Leakage current: ≥ 250 V according to IEC 60112

Other features

- Operating conditions CE: -20T60 / UL: 0T50, 90% RH non-condensing
- Storage conditions: -30T80, 90% RH non-condensing
- To be integrated in Class I and/or II appliances
- Index of protection: IP40 only on the front cover
- Period of electric stress across insulating parts: long
- Suitable for use in environments with degree of pollution 2
- Category of resistance to heat and fire: D
- Immunity against voltage surges: category II, category III for versions without display
- Software class and structure: class A

Compliance

CE mark

This product is designed to comply with the following EU standards:

- Low voltage directive LVD 2014/35/EU:
 - EN60730-1: 2011 (Automatic electrical control for household and similar use. General requirements)
 - EN60730-2-9: 2010 (Particular Requirements for Temperature Sensing Controls)
- Electromagnetic compatibility EMC directive 2014/30/EU:
 - EN 61000-6-3: 2007 +A1: 2011 (Emission standard for residential, commercial and light-industrial environments)
 - EN 61000-6-2: 2005 (Immunity for industrial environments)
- RoHS directive 2011/65/EU and 2015/863/EU:
 - EN50581: 2012
- China RoHS

UL approval:

- UL file E31024

General warnings

- Every use that is not described in this manual is considered incorrect and is not authorised by the manufacturer
- Verify that the installation and operating conditions of the device respect the ones specified in the manual, specially concerning the supply voltage and environmental conditions
- This device contains live electrical components therefore all the service and maintenance operations must be performed by qualified personnel
- The device can't be used as a safety device
- Liability for injury or damage caused by the incorrect use of the device lies solely with the user

Installation warnings

- Mounting position recommended: vertical
- The installation must be executed according the local standards and legislations of the country
- Always operate on the electrical connections with the device disconnected from the main power supply
- Before carrying out any maintenance operations on the device, disconnect all the electrical connections
- For safety reasons the appliance must be fitted inside an electrical panel with no live parts accessible
- Don't expose the device to continuous water sprays or to relative humidity greater than 90%.
Avoid exposure to corrosive or pollutant gases, natural elements, environments where explosives or mixes of flammable gases are present, dust, strong vibrations or shock, large and rapid fluctuations in ambient temperature that in combination with high humidity can condensate, strong magnetic and/or radio interference (e.g. transmitting antennae)
- When connecting loads beware of the maximum current for each relay and connector
- Use cable ends suitable for the corresponding connectors. After tightening the screws of connectors, slightly tug the cables to check their tightness
- Use appropriate data communication cables. Refer to the Installation Guide "MCX hardware network specification" for the kind of cable to be used and setup recommendations
- Reduce the path of the probe and digital inputs cables as much as possible, and avoid spiral paths enclosing power devices. Separate from inductive loads and power cables to avoid possible electromagnetic noises
- Avoid touching or nearly touching the electronic components fitted on the board to avoid electrostatic discharges
- The product is not suitable to be exposed directly to the Internet

DISCLAIMER: Professional Use Only

This product is not subject to the UK PSTI regulation, as it is for supply to and use only by professionals with the necessary expertise and qualifications. Any misuse or improper handling may result in unintended consequences. By purchasing or using this product, you acknowledge and accept the professional-use-only nature of its application. Danfoss does not assume any liability for damages, injuries, or adverse consequences ("damage") resulting from the incorrect or improper use of the product and you agree to indemnify Danfoss for any such damage resulting from your incorrect or improper use of the product.

Technical specifications

Power supply

- 21 – 265 V AC, 50/60 Hz. Maximum power consumption: 15 W. Insulation between power supply and the extra-low voltage: reinforced
- 40 – 230 V DC

Communication interface

| Interface | Use | Connector label | Technical data |
|-----------------------------------|---|--------------------|--|
| CANbus | Fieldbus for connection to user interfaces, MCX controllers, service tools etc. | CAN CAN-RJ | Physical layer according to ISO 11898-2 High Speed CAN bus Frame format according to CAN 2.0B specification Transceiver not isolated (power supply has reinforced isolation) |
| USB device | Prepared for future use | USB-DEV | Plug: Type Mini B |
| USB host | For connection to Flash drive for application software update, datalogging and service | USB-H | Plug: Type A |
| RS485-1 RS485-2 (MCX20B2 only) | Communication bus to BMS (e.g. Modbus slave), service tools, smart devices (e.g. Modbus master) RS485-1 can be polarized as master from the application | RS485-1 RS485-2 | Physical layer according to EIA 485 Ref3 Provide 500 V peak transient galvanic isolation |
| Ethernet | For web server functionality, integration (e.g. Modbus TCP) NOTICE! Do not route cable outside of buildings. Connect only to IT equipment compliant with EN 60950 or EN 62368 (Information technology equipment. Safety. General requirements) | ETHERNET | Interface type: 10 BASE-T and 100 BASE-TX, IEEE 802.3. MDI-X (Automatic medium-dependent interface crossover) |

Wire lengths

| Interface | Max wire length (m) | Max. baudrate (bps) | Min. wire size |
|---------------|---------------------|---------------------|----------------|
| Ethernet | 100 | 10/100 M | |
| CANbus | 1000 | 50 K | AWG18 |
| | 500 | 125 K | AWG22 |
| | 250 | 250 K | AWG24 |
| | 80 | 500 K | AWG26 |
| | 30 | 1 M | AWG26 |
| RS485 | 1000 | 125 K | AWG22 |
| Signal wiring | 30 | | |

Connection

| Connectors | Type | Dimensions |
|-------------------------------|-------------------------------------|--|
| Top Board | | |
| Digital input 1 connector | 3 way screw plug-in connector type | <ul style="list-style-type: none"> pitch 5 mm section cable 0.2 – 2.5 mm² |
| Analog input 11-14 connector | 7 way screw plug-in connector type | <ul style="list-style-type: none"> pitch 5 mm section cable 0.2 – 2.5 mm² |
| Digital input 2 connector | 3 way screw plug-in connector type | <ul style="list-style-type: none"> pitch 5 mm section cable 0.2 – 2.5 mm² |
| Digital input 3 connector | 3 way screw plug-in connector type | <ul style="list-style-type: none"> pitch 5 mm section cable 0.2 – 2.5 mm² |
| Digital input 4 connector | 3 way screw plug-in connector type | <ul style="list-style-type: none"> pitch 5 mm section cable 0.2 – 2.5 mm² |
| Digital input 5-8 connector | 5 way screw plug-in connector type | <ul style="list-style-type: none"> pitch 5 mm section cable 0.2 – 2.5 mm² |
| Bottom Board | | |
| Digital output 1-5 connector | 10 way screw plug-in connector type | <ul style="list-style-type: none"> pitch 5 mm section cable 0.2 – 2.5 mm² |
| Digital output 6 connector | 6 way screw plug-in connector type | <ul style="list-style-type: none"> pitch 5 mm section cable 0.2 – 2.5 mm² |
| Ethernet connector | 8 / 8 way RJ 45 plug type | |
| USB host connector | USB Type A | |
| Analog input 1-5 connector | 11 way screw plug-in connector type | <ul style="list-style-type: none"> pitch 5 mm section cable 0.2 – 2.5 mm² |
| Power supply connector | 2 way screw plug-in connector type | <ul style="list-style-type: none"> pitch 5 mm section cable 0.2 – 2.5 mm² |
| Digital output 9-13 connector | 10 way screw plug-in connector type | <ul style="list-style-type: none"> pitch 5 mm section cable 0.2 – 2.5 mm² |
| Analog output 1-2 connector | 8 way screw plug-in connector type | <ul style="list-style-type: none"> pitch 5 mm section cable 0.2 – 2.5 mm² |
| RS485 -2 connector | 3 way screw plug-in connector type | <ul style="list-style-type: none"> pitch 5 mm section cable 0.2 – 2.5 mm² |
| RS485-1connector | 3 way screw plug-in connector type | <ul style="list-style-type: none"> pitch 5 mm section cable 0.2 – 2.5 mm² |
| CAN connector | 4 way screw plug-in connector type | <ul style="list-style-type: none"> pitch 5 mm section cable 0.2 – 2.5 mm² |
| CAN-RJ connector | 6/6 way telephone RJ12 plug type | |
| USB DEV connector | USB Mini B | |

User interface

LCD Display

display mode: STN blue transmissive
 back-light: white LED back-light adjustable via software
 display format: 128 x 64 dots
 active visible area : 58 x 29 mm
 contrast: adjustable via software

Display settings adjustment

Setting of the LCD display like contrast and brightness might need to be adjusted due to external ambient factors. Press and release simultaneously the Enter and X key after power ON to access the BIOS menu and select the DISPLAY menu. Use UP and DOWN arrow keys to adjust the contrast or the brightness of the display at the desired level.

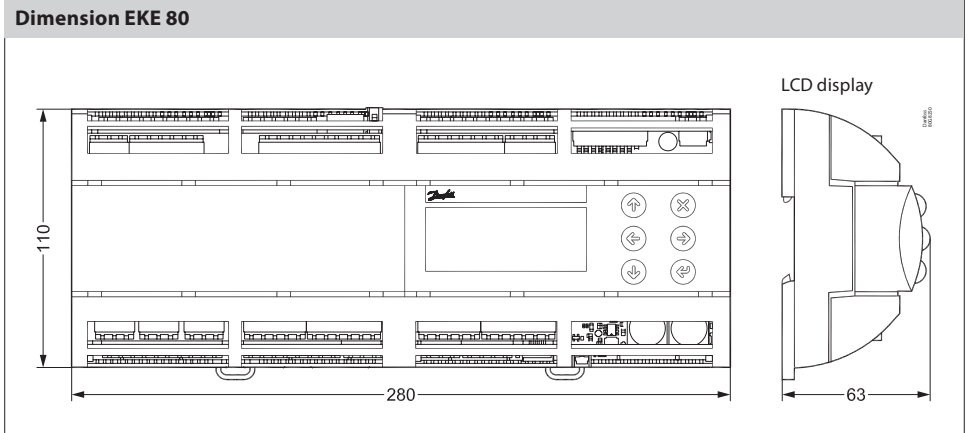
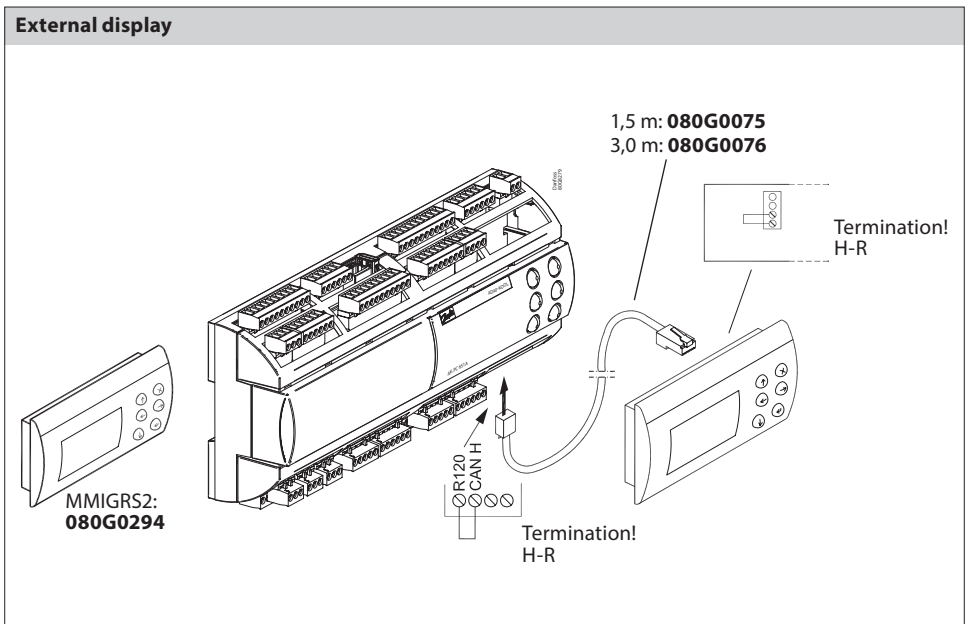

Connection, lower level

Warning
The supply voltage of AI may not share the signal with other controllers

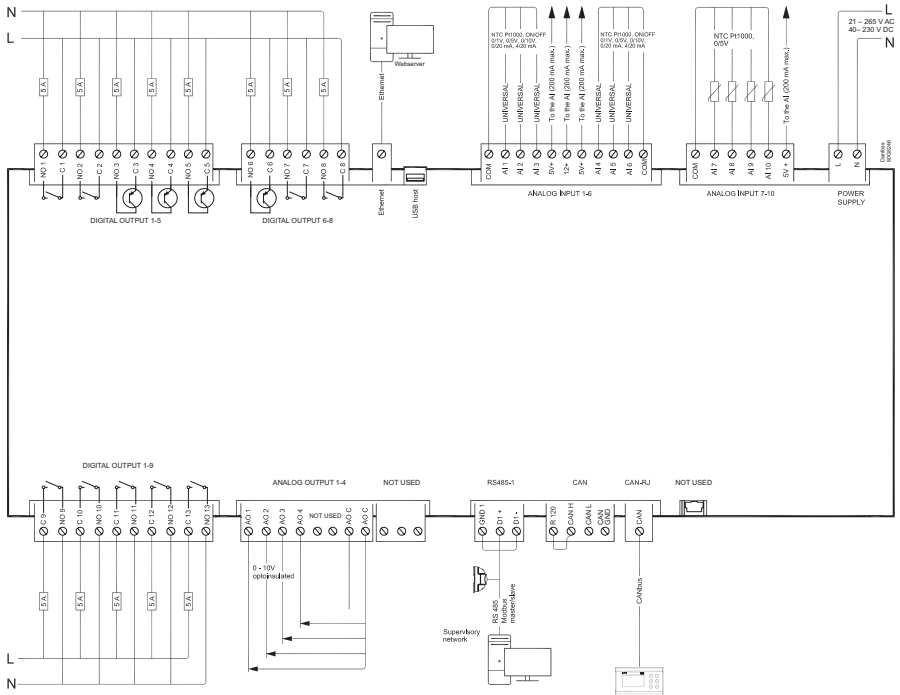

Connection, upper level

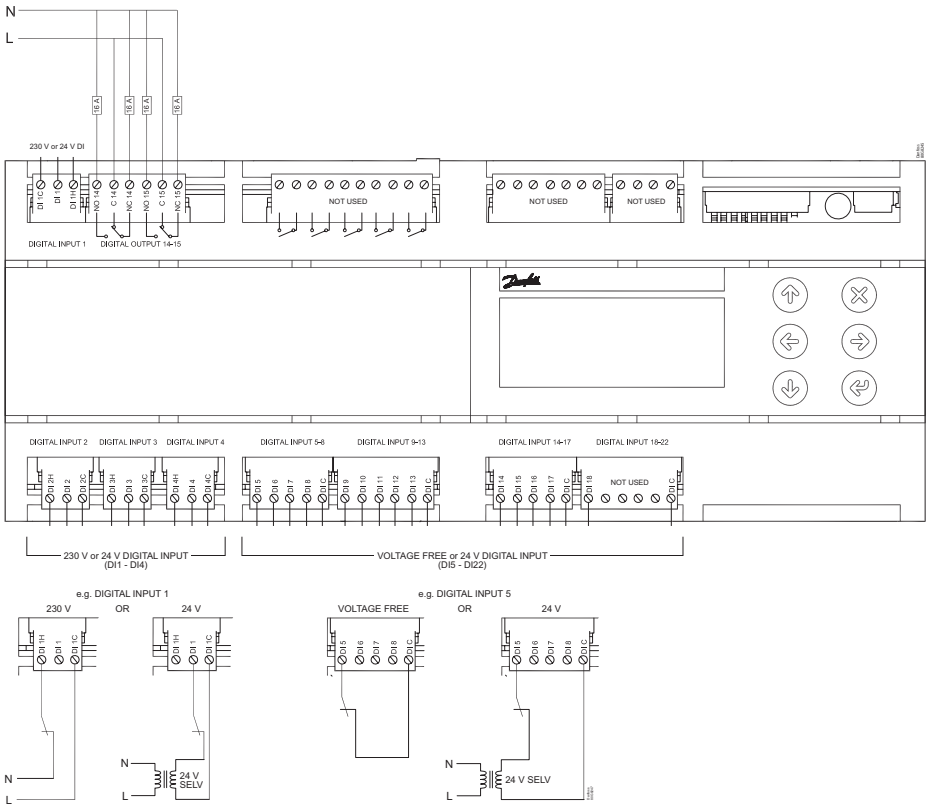

| AI | Label | Description | Signal type choice Via software or fieldbus | Default | Modbus register | Comment |
|-------|-------|--|--|---------|-----------------|---|
| AI-01 | AI1 | Capacity Reference | 0–10 V 0–5 V 2–10 V 0–20 mA 4–20 mA | 0–10 V | 17902 | Max 13.5 V input voltage. Do not connect voltage sources without current limitation (overall 80 mA) to analog inputs while unit is not powered |
| AI-02 | AI2 | ICAD Ejector Mode Feedback | 0–20 mA 4–20 mA | 4–20 mA | 17903 | |
| AI-03 | AI3 | ICAD Bypass Mode Feedback | 0–20 mA 4–20 mA | 4–20 mA | 17904 | |
| AI-04 | AI4 | Pressure Transmitter | 0–5 V 0–10 V 0–20 mA 4–20 mA | 4–20 mA | 17905 | |
| AI-05 | AI5 | Temperature Sensor | 0–10 V NTC–10K PT1000 | PT1000 | 17906 | |
| AI-06 | N/A | Not available for customer use | N/A | N/A | Reserved | Reserved |
| AI-07 | | | | | | |
| AI-08 | | | | | | |
| AI-09 | | | | | | |
| AI-10 | | | | | | |
| AI-11 | AI11 | Not used in logic. User configurable IO | None NTC–10K PT1000 0–5 V 0–10 V 2–10 V 0–20 mA 4–20 mA | None | 17907 | Max 13.5 V input voltage. Do not connect voltage sources without current limitation (overall 80 mA) to analog inputs while unit is not powered |
| AI-12 | AI12 | | | | 17908 | |
| AI-13 | AI13 | | | | 17909 | |
| AI-14 | AI14 | | | | 17910 | |
| AI-15 | N/A | Not available for customer use | N/A | N/A | Reserved | Reserved |
| AI-16 | | | | | | |
| A0 | Label | Description | Signal type choice | Default | Modbus register | Comment |
| A0-01 | A01 | ICAD Ejector Mode Request OD | 0–10 V 2–10 V | 0–10 V | 18102 | Analog Outputs galvanically isolated, minimum load 1K Ω (10 mA) for each output |
| A0-02 | A02 | ICAD Bypass Mode Request OD | 0–10 V 2–10 V | 0–10 V | 18103 | |
| A0-03 | N/A | Not available for customer use | N/A | – | Reserved | Reserved |
| A0-04 | | | | | | |
| A0-05 | | | | | | |
| A0-06 | | | | | | |

| DI | Label | Description | Signal type choice | Default | Modbus register | Comment |
|-------|-------|---|---|---------|-----------------|---|
| DI-01 | DI1 | Not used in logic User configurable IO | 24 V or 230 V depending on port used. See upper level diagram | - | 17498 | 24 V Opto isolated, 24 V AC 50/60 Hz or 24 V DC Rated current: 5 mA @ 24 V AC 230 V Opto isolated, 86–265 V AC / 50/60 Hz, Reinforced isolation, Rated current: 2,5 mA @ 265 V AC |
| DI-02 | DI2 | Not used in logic User configurable IO | | | 17499 | |
| DI-03 | DI3 | Not used in logic User configurable IO | | | 17500 | |
| DI-04 | DI4 | Not used in logic User configurable IO | | | 17501 | |
| DI-05 | DI5 | Suction Flow Control | Dry contact and/or 24 V AC | - | 17503 | As the inputs are not isolated, caution has to be used when applying 24 V AC: the same polarity of the supply MUST always be used on COM/GND connection. Counting function with max frequency of 16.6 Hz (30 ms minimum pulse time) |
| DI-06 | DI6 | Ejector Mode Signal Error | | | 17504 | |
| DI-07 | DI7 | Bypass Mode Error Signal | | | 17505 | |
| DI-08 | N/A | Not used in logic | N/A | N/A | Reserved | Reserved |
| DI-09 | | | | | | |
| DI-10 | | | | | | |
| DI-11 | | | | | | |
| DI-12 | | | | | | |
| DI-13 | | | | | | |
| DI-14 | | | | | | |
| DI-15 | | | | | | |
| DI-16 | | | | | | |
| DI-17 | | | | | | |
| DI-18 | | | | | | |
| DI-19 | | | | | | |
| DI-20 | | | | | | |
| DI-21 | | | | | | |
| DI-22 | | | | | | |

| DO | Label | Description | Signal type choice | Default | Modbus register | Comment |
|-------|-------|-----------------------|--|--------------|-----------------|--|
| DO-01 | DO1 | Alarm output | | - | 17702 | 5 A 250 V AC for resistive loads – 100,000 cycles 3 A 250 V AC for inductive loads – 100,000 cycles with $\cos(\phi) = 0.4$ UL: 3 A resistive, 250 V AC, 100,000 cycles; 1/8 hp, 125/250 V AC, 30,000 cycles; C300 pilot duty, 125/250 V AC, 30,000 cycles |
| DO-02 | N/A | Not used in logic | N/A | N/A | Reserved | |
| DO-03 | DO3 | User assigned Ejector | Not assigned Ejector 1 Ejector 2 Ejector 3 Ejector 5-8 expansion module only | Not assigned | 17703 | Internal Solid State Relay for Industrial Ejector Coils: 15–280 V _{rms} , 0.5 A UL: Making current: 7 A, Breaking current: 0.7 A, Pilot duty ($\cos \theta$ 0.35), 240 V AC, N.O IMPORTANT: For a Multi-Ejector, an external Solid State Relay is necessary between the assigned DO and the Multi-Ejector solenoid coils that meets the following specification: Leakage current suppression. At least 2 A rating for both 110 V and 230 V Multi-Ejector coils. IMPORTANT: Ejectors 5 to 8 can only be assigned to an extension module. An extension module is the same controller device as this device except that it is user-configured/ defined as an extension module for control of extra Ejectors i.e., when there are more than 4 Industrial Ejectors. |
| DO-04 | DO4 | User assigned Ejector | | Not assigned | 17704 | |
| DO-05 | DO5 | User assigned Ejector | | Not assigned | 17705 | |
| DO-06 | DO6 | User assigned Ejector | | Not assigned | 17706 | |
| DO-07 | N/A | Not used in logic | N/A | N/A | Reserved | N/A |
| DO-08 | | | | | | |
| DO-09 | | | | | | |
| DO-10 | | | | | | |
| DO-11 | | | | | | |
| DO-12 | | | | | | |
| DO-13 | | | | | | |
| DO-14 | | | | | | |
| DO-15 | | | | | | |
| DO-16 | | | | | | |
| DO-17 | | | | | | |
| DO-18 | | | | | | |
| DO-19 | | | | | | |
| DO-20 | | | | | | |

Danfoss A/S
Climate Solutions • danfoss.com • +45 7488 2222

Any information, including, but not limited to information on selection of product, its application or use, product design, weight, dimensions, capacity or any other technical data in product manuals, catalogues descriptions, advertisements, etc. and whether made available in writing, orally, electronically, online or via download, shall be considered informative, and is only binding if and to the extent, explicit reference is made in a quotation or order confirmation. Danfoss cannot accept any responsibility for possible errors in catalogues, brochures, videos and other material. Danfoss reserves the right to alter its products without notice. This also applies to products ordered but not delivered provided that such alterations can be made without changes to form, fit or function of the product.
All trademarks in this material are property of Danfoss A/S or Danfoss group companies. Danfoss and the Danfoss logo are trademarks of Danfoss A/S. All rights reserved.