

Installation Guide

VLT[®] All-mode Filter MCC 201

6-65 A

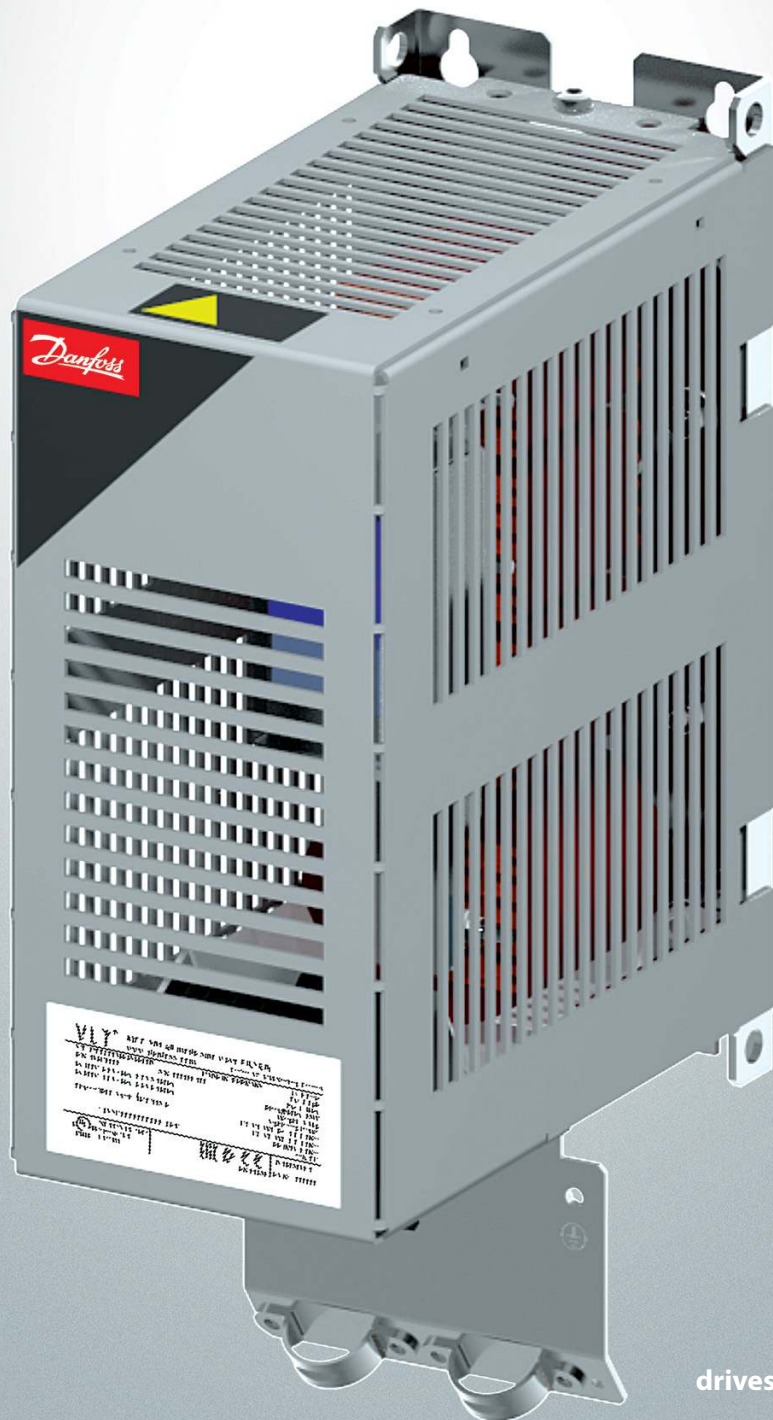

Contents

1 Installation

1.1 Qualified Personnel	5
1.2 Trademarks	5
1.3 Supported Drive Series	5
1.4 Safety Symbols	5
1.5 Safety Precautions	7
1.6 Required Tools	8
1.7 Verifying the Shipment and the Contents	8
1.8 EMC-compliant Installation	9
1.9 Installing the Filter	9
1.10 Cable Sizes	10

2 Specifications

2.1 Product Approvals and Certifications	11
2.2 Operating Environment	11
2.3 Mechanical Specifications	12
2.4 Electrical Specifications	13
2.5 Ratings	13
2.6 Selection of VLT® All-mode Filter MCC 201	14

3 Illustrations

1 Installation

1.1 Qualified Personnel

To allow trouble-free and safe operation of the unit, only qualified personnel with proven skills are allowed to transport, store, assemble, install, program, commission, maintain, and decommission this equipment.

Persons with proven skills:

- Are qualified electrical engineers or persons who have received training from qualified electrical engineers and are suitably experienced to operate devices, systems, plants, and machinery in accordance with pertinent laws and regulations.
- Are familiar with the basic regulations concerning health and safety/accident prevention.
- Have read and understood the safety guidelines given in all guides provided with the unit, especially the instructions given in the operating guide of the drive.
- Have good knowledge of the generic and specialist standards applicable to the specific application.
- Are familiar with the structure and operation of medium-voltage drives and the related risks. Special training for medium-voltage installations may be necessary.

1.2 Trademarks

VLT® is a registered trademark for Danfoss A/S.

1.3 Supported Drive Series

The VLT® All-mode Filter MCC 201 is compatible with the following AC drives.

- VLT® HVAC Drive FC 102.
- VLT® Refrigeration Drive FC 103.
- VLT® AQUA Drive FC 202.
- VLT® AutomationDrive FC 302.

1.4 Safety Symbols

The following symbols are used in Danfoss documentation.

DANGER

Indicates a hazardous situation which, if not avoided, will result in death or serious injury.

WARNING

Indicates a hazardous situation which, if not avoided, could result in death or serious injury.



CAUTION

Indicates a hazardous situation which, if not avoided, could result in minor or moderate injury.

NOTICE

Indicates information considered important, but not hazard-related (for example, messages relating to property damage).

The guide also includes ISO warning symbols related to hot surfaces and burn hazard, high voltage and electrical shock, and referring to the instructions.

	ISO warning symbol for hot surfaces and burn hazard
	ISO warning symbol for high voltage and electrical shock
	ISO action symbol for referring to the instructions

1.5 Safety Precautions

NOTICE

THE VLT® ALL-MODE FILTER MCC 201 IS DESIGNED FOR USE WITH VLT® DRIVES ONLY.

- Danfoss takes no responsibility for the use of third-party filters installed with Danfoss Drives.
- Danfoss Drives that are compatible with the VLT® All-mode Filter MCC 201 are listed in the [1.3 Supported Drive Series](#).

WARNING

LIFTING HEAVY LOAD

The filter is heavy. Failure to follow local safety regulations for lifting heavy weights may cause death, personal injury, or property damage.

- Follow local regulations for lifting.
- Check the weight of the filter. The weight is provided on the outside of the shipping box and the exterior of the filter.
- If needed, ensure that the lifting equipment is in proper working condition and can safely lift the weight of the filter.
- Use the integrated lifting eyes to lift the filter. The lifting eyes are not aligned with the center of gravity of the filter, which causes that the filter is not level when lifted.

WARNING

DISCHARGE TIME

The drive and filter contain capacitors that can remain charged even when the drive is powered off. High voltage can be present in filter terminals even when the drives warning indicator lights are off. Failure to wait the specified time after power has been removed before performing service or repair work can result in death or serious injury.

- Stop the motor.
- Disconnect all power sources, including permanent magnet type motors.
- Wait for the drive capacitors to discharge fully. The discharge time is shown on the exterior of the drive.
- Verify full discharge by measuring the voltage level between the motor phases on the filter output terminals (U2, V2, W2).

WARNING



INDUCED VOLTAGE

Induced voltage from output motor cables that run together can charge equipment capacitors, even with the equipment turned off and locked out/tagged out. Failure to run output motor cables separately, or to use shielded cables, could result in death or serious injury.

- Run output motor cables separately or use shielded cables.
- Simultaneously lock out/tag out all the drives.

⚠ WARNING



ELECTRICAL SHOCK HAZARD

Due to the stray capacitance of the shielded motor cable, the leakage currents exceed 3.5 mA. Failure to connect the drive or filter properly to protective earth may result in death or serious injury.

- Ensure that the minimum size of the ground conductor complies with the local safety regulations for high touch current equipment.
- Ensure reinforced protective earthing (PE) conductor according to IEC 60364-5-54 cl. 543.7 or local safety regulations for equipment with leakage current >3.5 mA.
- PE conductor with a cross-section of at least 10 mm² (8 AWG) Cu or 16 mm² (6 AWG) Al, or an additional PE conductor of the same cross-sectional area as the original PE conductor as specified by IEC 60364-5-54, with a minimum cross-sectional area of 2.5 mm² (14 AWG) mechanically protected or 4 mm² (12 AWG) not mechanically protected.
- PE conductor completely enclosed within an enclosure or otherwise protected throughout its length against mechanical damage.
- PE conductor that is part of a multi-conductor power cable with a minimum PE conductor cross-section of 2.5 mm² (14 AWG) that is permanently connected or plugged in by an industrial connector. The multi-conductor power cable must be installed with an appropriate strain relief.

1.6 Required Tools

- Lifting aid.
- Tape measure.
- Wrench with extension and various sockets (see the wiring illustrations for the specific size).
- Torx and pozidrive screwdrivers (SL1.2, SL1.6, T25, T30, SW5, SW6, SW8).
- Wire crimper.

1.7 Verifying the Shipment and the Contents

Make sure that the items supplied and the information on the product label correspond to the order confirmation. The product label is found on the front of the filter.

1 —	VLT ®	MCC 201 all-mode sine-wave FILTER		
	www.danfoss.com		Danfoss A/S, 6430 Nordborg, Denmark	5
2 —	T/C: MCC201A5K5T3E20B	MADE IN GERMANY	L = 8.0mH	6
3 —	P/N: 175U6006	S/N: 000166-154	Cy = 2.2µF	7
4 —	3x 400V: 5.6A <5Hz 6.0A 5-150Hz		fsw: ≥ 4kHz	8
	3x 500V: 4.2A <5Hz 5.5A 5-150Hz		Ploss@50Hz: 83W	
	Chassis/IP20 Tamb. 45°C/113°F		Weight: 7.7kg	9
			Tightening torque	
			U1, V1, W1, R+: 1.2-2.0Nm	
			U2, V2, W2: 2.0-4.0Nm	
			PE (M6): 6.0Nm	
			only CU	
	 *175U6006000166-154*			
	 IND.CONT.EQ. 1HD1 ta(max)=45°C E 219022	  EN 61558	B 1903076.1 FA-Nr.: 000000	

e30b18.10

Figure 1: Example of an All-mode Filter MCC 201 Product Label

1	Product type	2	Type code
3	Part number	4	Voltage range, motor frequency, and current
5	Serial number	6	Inductance value
7	Capacitance value	8	Minimum switching frequency
9	Terminal torque for motor cables		

1.8 EMC-compliant Installation

Follow the same guidelines for filter installation as for drive installation. For EMC-compliant installation guidelines, refer to the drive design or installation guide, and follow the electrical installation instructions.

- Shielded cables or unshielded cables within metal conduit are required between the filter and the drive, and between the filter and the motor.
- Connect the shield to the filter at both ends.
- If possible provide a minimum 200 mm (7.9 in) separation between mains input, motor cables, and control cables.
- Convey the currents back to the unit using the included EMC plate. Ensure good electrical contact from the EMC plate through the mounting screws to the filter chassis. Mount the EMC plate during the installation of the filter.

1.9 Installing the Filter

Installation location is important. Full nominal current is available when the following installation conditions are met:

- Maximum surrounding air temperature is 45 °C (113 °F).
- Minimum surrounding air temperature is -30 °C (22 °F).
- The altitude is less than 1000 m (3280 ft) above sea level.
- There is enough free space above and below the filter.
- Vibration levels according to IEC 60721-3-3:2019 have been considered.

For temperatures and altitudes outside this range, and derating values, see the *Specifications* section.



NOTE: Do not mount the filter close to other heating elements or heat sensitive material.

1. Identify All-mode Filter frame. See step 1 in the [3 Illustrations](#) section.
2. Make sure that the operating environment and electrical installation meet the environmental conditions according to IEC 61800-2:2021. Unless stated otherwise, the same standards apply for the filters as for the drives.

- Indoor unconditioned/pollution degree 2.
- Overvoltage category 3.

3. Provide required clearance above and below the filter. See step 2 in the [3 Illustrations](#) section.

The VLT® All-mode Filter MCC 201 can be side-mounted with the VLT® drive. There are no spacing requirements between the VLT® All-mode Filter MCC 201 and the VLT® drive.

4. Mount the filter on or against a solid, non-combustible mounting surface such as concrete or metal.

- Use 4 screws for vibration levels specified in IEC 60721-3-3:2019 3M11 and IEC 60721-3.3:2019 3M12.

5. Install the filter following steps 1–3 in the [3 Illustrations](#) section.

Certain illustrations or steps apply to specific filter frames and are marked as such.

1.10 Cable Sizes

NOTICE



WIRING GUIDELINES

All wiring must comply with local and national regulations regarding cross-section and ambient temperature requirements. Loose connections can cause equipment faults or reduced performance.

- Minimize interference by keeping control wires as short as possible and separate from high-power cables.
- Tighten the terminals according to the proper torque value shown in the illustrations.
- Follow the same guidelines for filter cables as for drive cables. For more information, refer to the design guide for the specific VLT® drive.

Shielded cable is required between drive output and filter input:

The shield connections must exhibit the smallest possible impedance. Recommended, use the shield connection-blades from the accessory bag.

Ground the filter before switching on the power. Use the enclosed protective earth terminal from the accessory bag to ensure the best possible grounding.

2 Specifications

2.1 Product Approvals and Certifications

The VLT® All-mode Filter MCC 201 complies with the required standards and directives. For a list of product approvals and certifications, see the product label. Certificates and Declarations of Conformity are available on request or at <https://www.danfoss.com>.

Table 1: Approvals and Certifications Applicable to the VLT® All-mode Filter MCC 201

Approval	Description
	The filter complies with relevant directives and their related standards for the extended Single Market in the European Economic Area. The filter complies with EN/IEC 61558-2-20:2011.
	The Underwriters Laboratory (UL) mark indicates the safety of products and their environmental claims based on standardized testing. The all-mode filters are UL-certified up to 500 V. The 6A–24A filters comply with UL 508. For the UL file number, see the product label.
	The filter complies with all technical regulations of the Eurasian Customs Union.
	The filter complies with relevant directives and their related standards for the Morocco market.

2.2 Operating Environment

Table 2: Operating Environment Specifications for the VLT® All-mode Filter MCC 201

Function	Data
Ambient temperature during transport	-10...45 °C (14–113 °F)
Ambient temperature during storage	-10...45 °C (14–113 °F)
Ambient temperature during operation	Minimum (without derating): - 10 °C (14 °F)
	Maximum (with derating): 1.4%/K (>45 °C) (1.4%/K (>113 °F))
Altitude	Maximum (without derating): 1000 m (3250 ft)
	Maximum (with derating): 2000 m (6500 ft) (Power derating 0.95)
Chemically active substances	–
Pollution degree	2
Vibration	IEC 60721-3-3:2019 3M11: Standard classification requires 4 screws to install the frames.
	IEC 60721-3-3:2019 3M12: Standard classification requires 4 screws to install the frames.

2.3 Mechanical Specifications

Table 3: Weight and Terminal Cable Size for the VLT® All-mode Filter MCC 201

P/N	Weight [kg (lb)]	Terminal cable size	
		Minimum [mm ² (AWG)]	Maximum [mm ² (AWG)]
175U6006	7.7 (17)	0.2 (24)	16 (6)
175U6013	15.9 (35)	0.2 (24)	35 (2)
175U6024	28.1 (62)	2.5 (14)	50 (1-1/0)
175U6046	43.4 (96)	2.5 (14)	95 (3/0)
175U6065	69.7 (154)	10 (8)	120 (4/0)

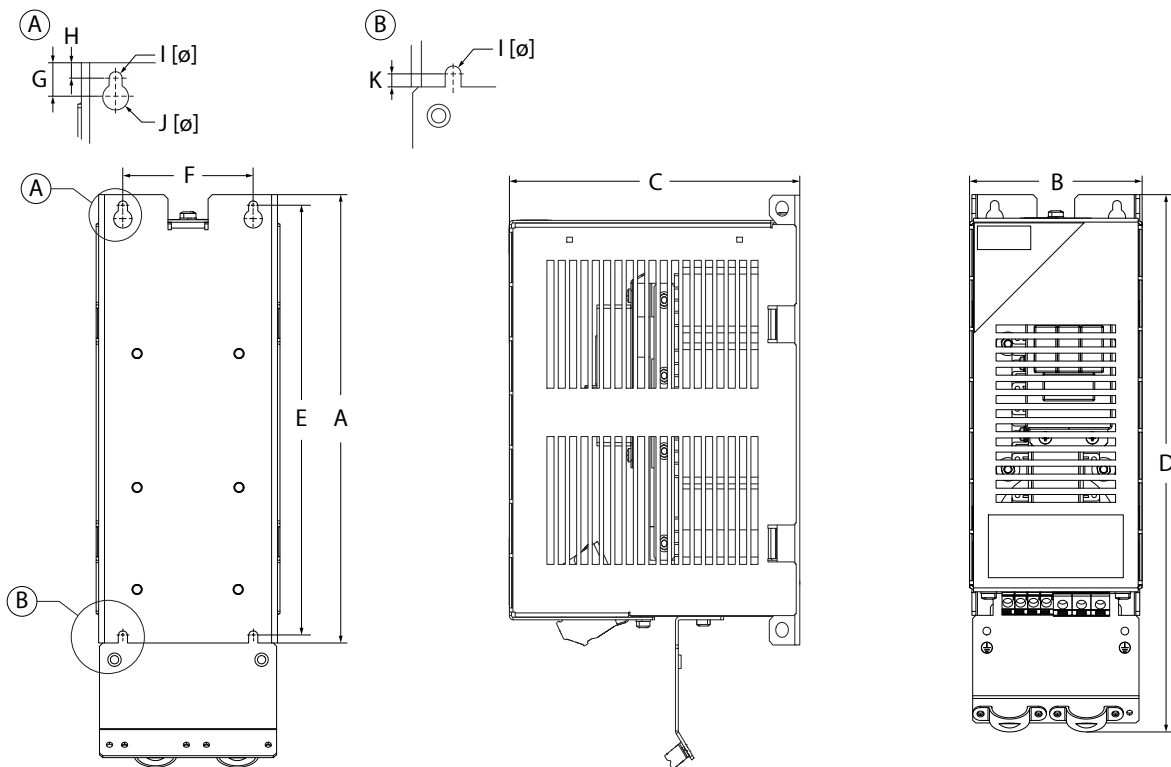

e30b637.10

Figure 2: Example of VLT® All-mode Filter MCC 201 Dimension Drawing
Table 4: Exterior Dimensions for the VLT® All-mode Filter MCC 201 [mm (in)]

P/N	A	B	C	D	E	F	G	H	I	J	K
175U6006	268 (10.5)	110 (4.3)	205 (8.1)	343 (13.5)	257 (10.1)	78 (3.1)	14.5 (0.5)	6.5 (0.2)	5.5 (0.2)	11 (0.4)	4.5 (0.1)
175U6013	338 (13.3)	131 (5.2)	210 (8.3)	419 (16.5)	327 (12.9)	100 (3.9)	14.5 (0.5)	6.5 (0.2)	5.5 (0.2)	11 (0.4)	4.5 (0.1)
175U6024	399 (15.7)	165 (6.5)	292 (11.5)	543 (21.4)	380 (14.9)	125 (4.9)	16.1 (0.6)	8.1 (0.3)	7.0 (0.2)	12 (0.5)	10.9 (0.4)

Table 4: Exterior Dimensions for the VLT® All-mode Filter MCC 201 [mm (in)] (continued)

P/N	A	B	C	D	E	F	G	H	I	J	K
175U6046	518 (20.4)	201 (7.9)	314 (12.4)	692 (27.2)	501 (19.7)	148 (5.8)	20 (0.8)	9.0 (0.4)	9.0 (0.4)	16 (0.6)	8 (0.3)
1756065	550 (21.7)	231 (9.1)	366 (14.4)	739 (29.1)	529 (20.8)	175 (6.9)	20.5 (0.8)	9.5 (0.4)	8.5 (0.3)	16 (0.6)	11.5 (0.4)

2.4 Electrical Specifications

Table 5: Electrical Specifications for the VLT® All-mode Filter MCC 201

Function	Data
Cooling	AN (Air Natural)
Overload rating	1.5 rated current for 1 minute/hour
Maximum motor cable length	1000 m (3250 ft) shielded without derating. Power derating: 5 %/1km (>1 km)
Switching frequency ⁽¹⁾	(4–16 kHz)
Discharge time	>5 s ⁽²⁾
Filter impedance	~6.5% (400 V/50 Hz/nominal current)
Acoustical noise	<80 dB(A) - depending on working point
Lifetime	10 years considering the filter is running 2/3 of the day (The operating hours of the filter is 60.000). ⁽³⁾
	5 years considering the filter is running 2/3 of the day (The operating hours of the filter is 30.000). ⁽⁴⁾

1) The maximum switching frequency is the maximum setting of the VLT® drive.

2) If the motor is connected and at standstill, the voltage is below 60 V (phase to phase) ripple-free DC in less than 5 s.

3) Condition: 4 kHz switching frequency, 400 V mains voltage, 50 Hz motor speed, 80% of nominal current.

4) Condition: 4 kHz switching frequency, 500 V mains voltage, 50 Hz motor speed, 100% of nominal current.

2.5 Ratings

Table 6: Ratings for the VLT® All-mode Filter MCC 201

P/N	Rated current rating at supply voltage and motor frequency ⁽¹⁾				L-value [mH] ⁽²⁾	Cy-value [uF]	Power loss	
	380–440 V		441–500 V				50 Hz at rated current [W]	Maximum [W] ⁽³⁾
	<5 Hz [A]	5–150 Hz [A]	<5 Hz [A]	5–150 Hz [A]				
175U6006	5.6	6.0	4.2	5.5	8.0	2.2	83	114
175U6013	12.1	13.0	9.2	12.0	3.2	4.7	183	229
175U6024	22.3	24.0	17.7	23.0	2.0	6.8	224	294

Table 6: Ratings for the VLT® All-mode Filter MCC 201 (continued)

P/N	Rated current rating at supply voltage and motor frequency ⁽¹⁾				L-value [mH] ⁽²⁾	Cy-value [uF]	Power loss	
	380–440 V		441–500 V				50 Hz at rated current [W]	Maximum [W] ⁽³⁾
	<5 Hz [A]	5–150 Hz [A]	<5 Hz [A]	5–150 Hz [A]				
175U6046	42.8	46.0	33.5	43.5	1.0	16.4	310	464
175U6065	60.5	65.0	47.7	62.0	0.75	24.6	550	845

1) Maximum ambient temperature without derating 45 °C. Ambient temperature: -10 – 45 °C. Derating > 45 °C = 1,4% / °C. Derating > 1 km = 5% / 1 km.

2) Phase-phase inductance.

3) Maximum power loss at low motor frequency and rated current.

2.6 Selection of VLT® All-mode Filter MCC 201

See [1.3 Supported Drive Series](#) for the VLT® All-mode Filter MCC 201.

Table 7: Terminology Used in the VLT® All-mode Filter MCC 201 Selection Table

Term	Description
Rated output current	The rated output current of the drive in the given voltage supply range and selected overload capability.
Rated current	The rated current of the filter in the given voltage supply range.
P/N	Part number of the VLT® All-mode Filter MCC 201. Protection ratings are IP20.

Table 8: Selection Table for VLT® All-mode Filter MCC 201

Drive values for T4/T5 types				VLT® All-mode Filter MCC 201 values				
Power rating [kW (hp)] ⁽¹⁾	Rated output current		Switching frequency [kHz] ⁽²⁾	[P/N]	Rated current			
	380–440 V [A]	441–500 V [A]			380–440 V		441–500 V	
					< 5 Hz [A]	5–150 Hz [A]	< 5 Hz [A]	5–150 Hz [A]
0.37 (0.5)	1.3	1.2	5	175U6006	5.6	6.0	4.2	5.5
0.55 (0.75)	1.8	1.6						
0.75 (1)	2.4	2.1						
1.1 (1.5)	3.0	2.7						
1.5 (2)	4.1	3.4						
2.2 (3)	5.6	4.8						

Table 8: Selection Table for VLT® All-mode Filter MCC 201 (continued)

Drive values for T4/T5 types				VLT® All-mode Filter MCC 201 values				
Power rating [kW (hp)] ⁽¹⁾	Rated output current		Switching frequency [kHz] ⁽²⁾	[P/N]	Rated current			
	380–440 V [A]	441–500 V [A]			380–440 V		441–500 V	
					< 5 Hz [A]	5–150 Hz [A]	<5 HZ [A]	5–150 Hz [A]
3.0 (4)	7.2	6.3	5	175U6013	12.1	13.0	9.2	12.0
4.0 (5)	10.0	8.2						
5.5 (7.5)	13.0	11.0						
7.5 (10)	16.0	14.6	5	175U6024	22.3	24.0	17.7	23.0
11.0 (15)	24.0	21.0	4					
15.0 (20)	32.0	27.0	4	175U6046	42.8	46.0	33.5	43.5
18.5 (25)	37.5	34.0						
22.0 (30)	44.0	40.0						
30.0 (40)	61.0	52.0	4	175U6065	60.5	65.0	47.7	62.0
37.0 (50) ⁽³⁾	73.0	65.0						

1) Power rating from actual operating conditions.

2) Resulting switching frequency by P14-55 Output Filter, [5] All-mode filter.

3) Ensure that the nominal current rating from the all-mode filter is not exceeded.

3 Illustrations

1 175U6006

e30b1626.10

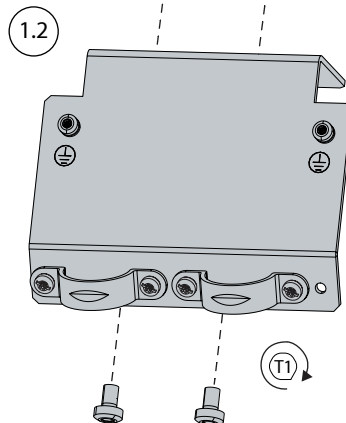
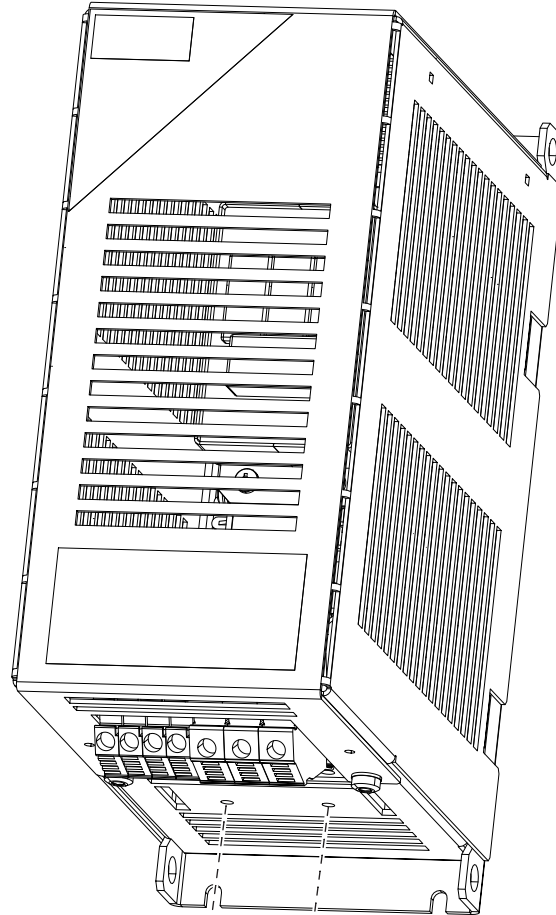
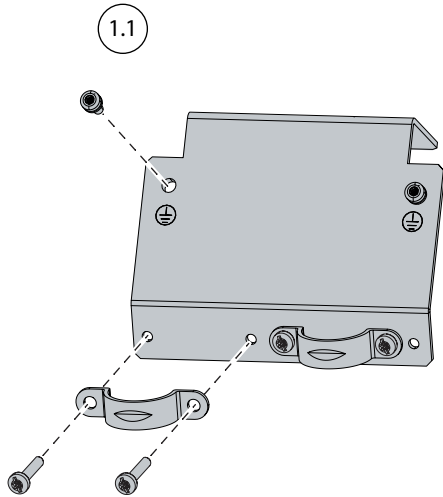

T1 – [3.5 Nm (31 in-lb)]

1 175U6013

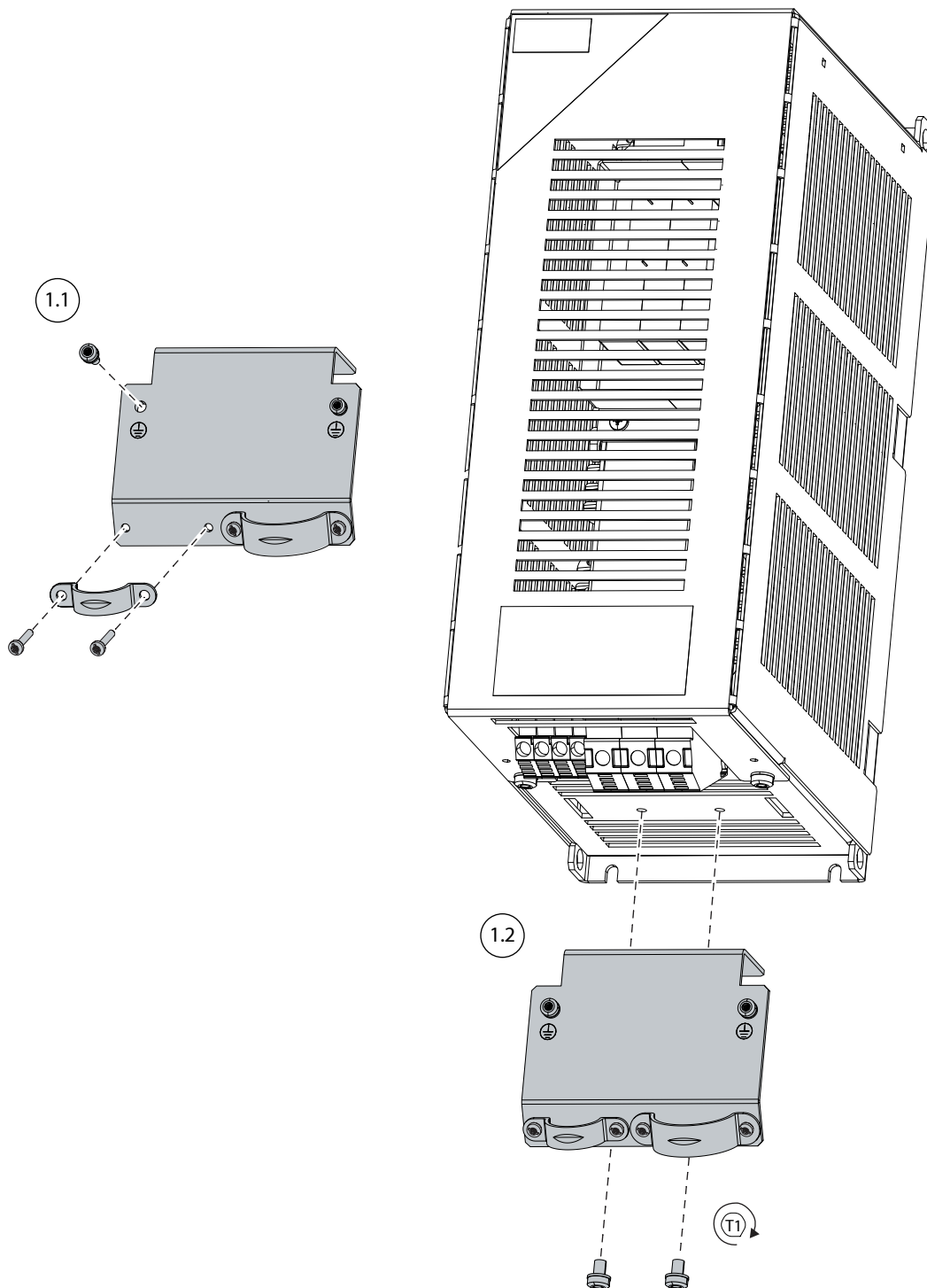

T1 - [3.5 Nm (31 in-lb)]

1 175U6024

1.1

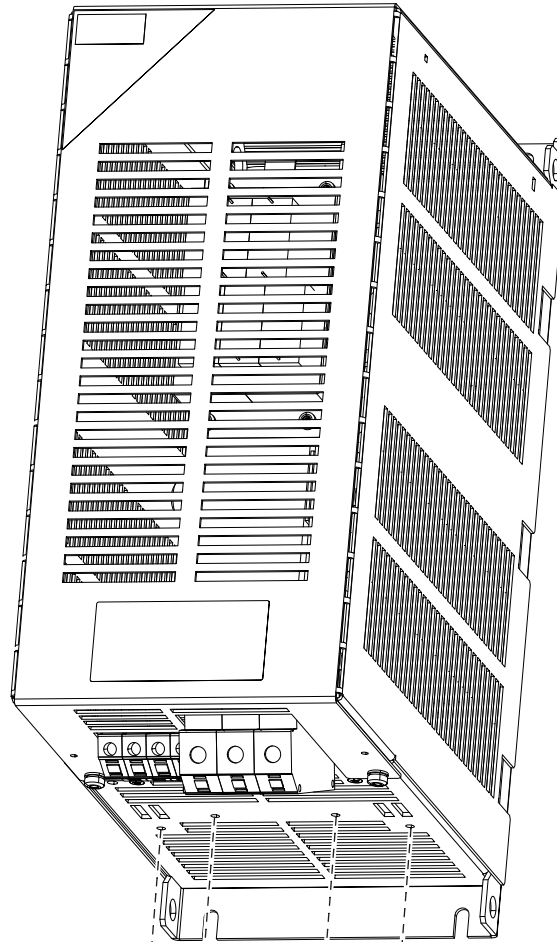
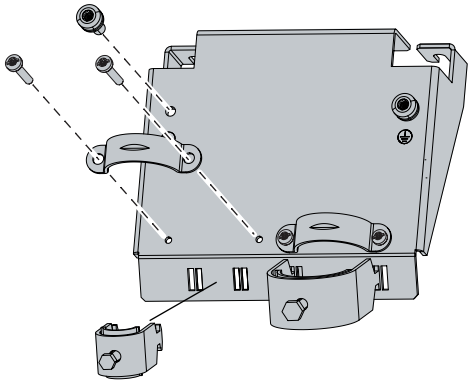

1.2

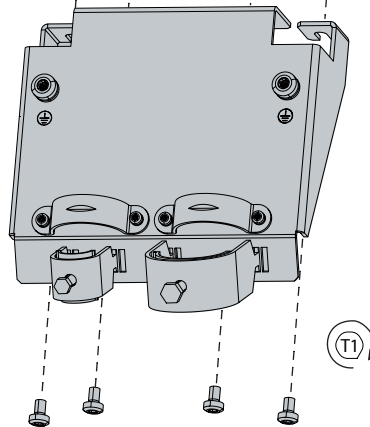

T_1 - [3.5 Nm (31 in-lb)]

1 175U6046

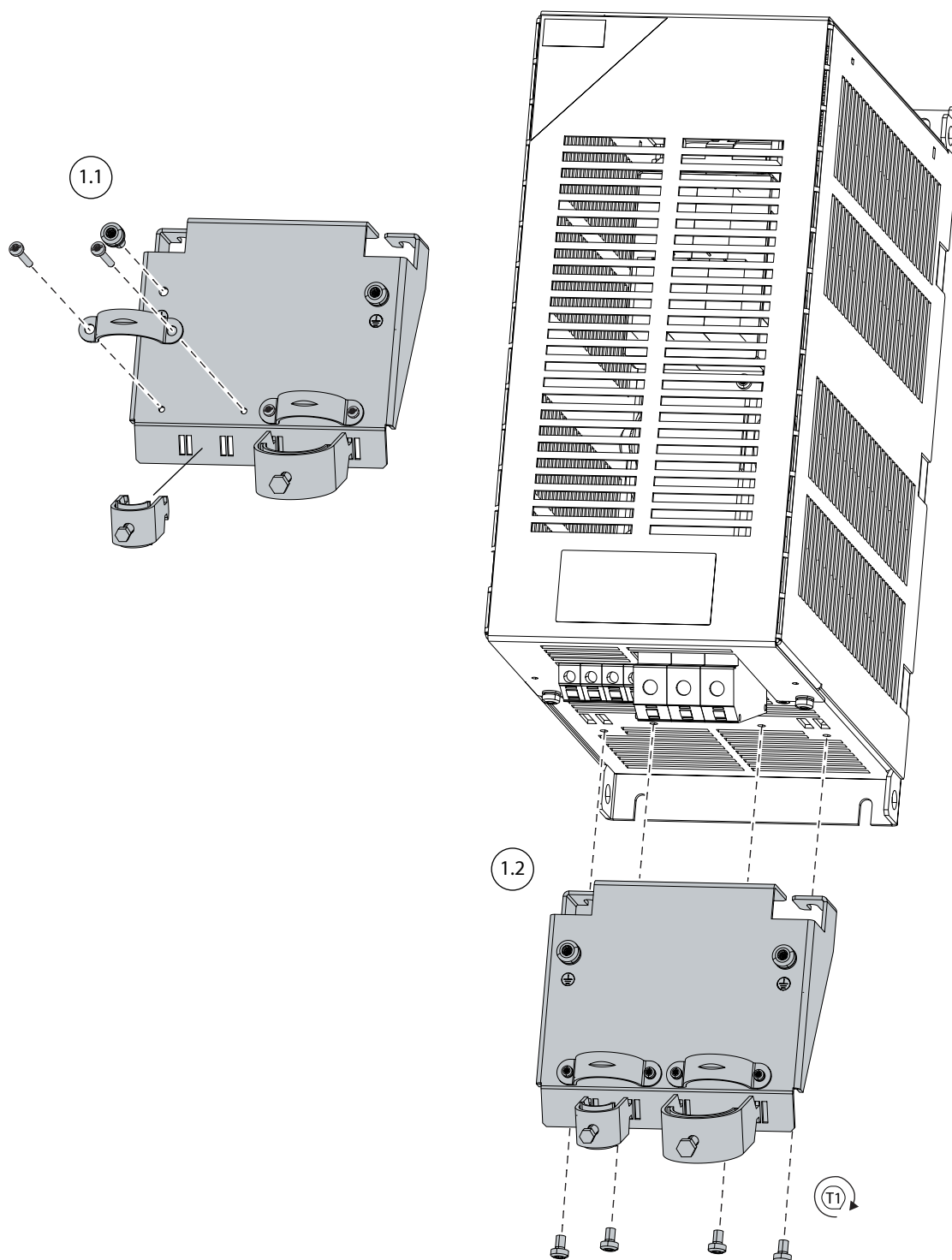

(T1) - [3.5 Nm (31 in-lb)]

e30b1630.10

1 175U6065

1.1

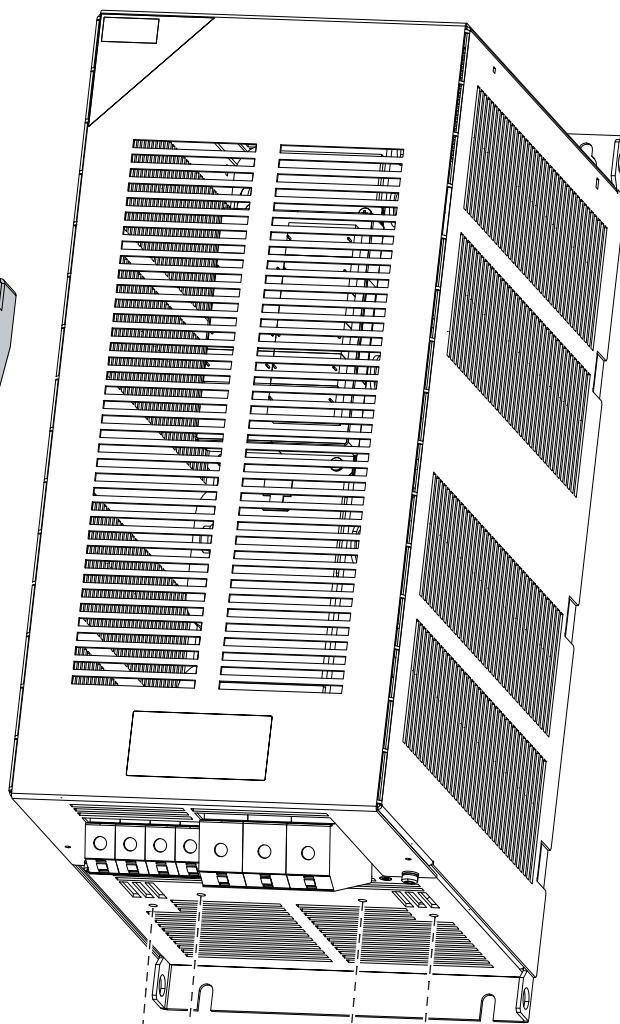
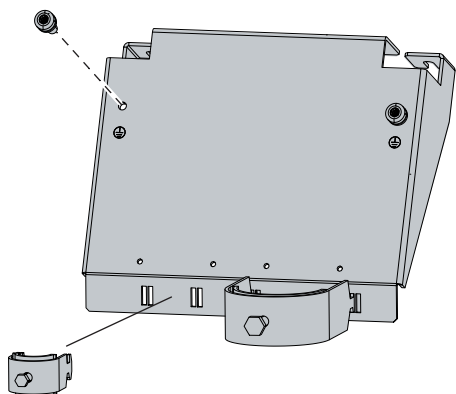

1.2

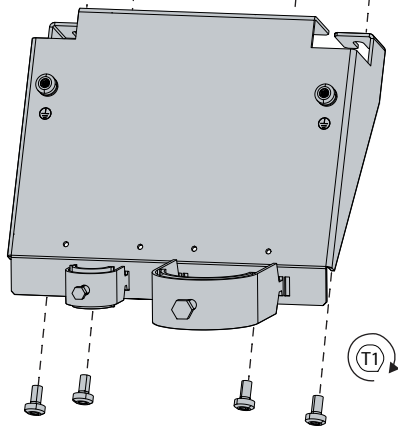

T1

T1 - [6.0 Nm (53 in-lb)]

2

mm (in)	175U6006	175U6013	175U6024	175U6046	175U6065
A	257 (10.1)	327 (12.9)	380 (15.0)	501 (19.7)	529 (20.8)
B	78 (3.1)	100 (3.9)	125 (4.9)	148 (5.8)	175 (6.9)
C1	≥ 100 (≥ 3.9)	≥ 100 (≥ 3.9)	≥ 100 (≥ 3.9)	≥ 100 (≥ 3.9)	≥ 100 (≥ 3.9)
C2	≥ 100 (≥ 3.9)	≥ 100 (≥ 3.9)	≥ 100 (≥ 3.9)	≥ 100 (≥ 3.9)	≥ 100 (≥ 3.9)
	4 x M5	4 x M5	4 x M6	4 x M8	4 x M8

e30b1622.10

2.1

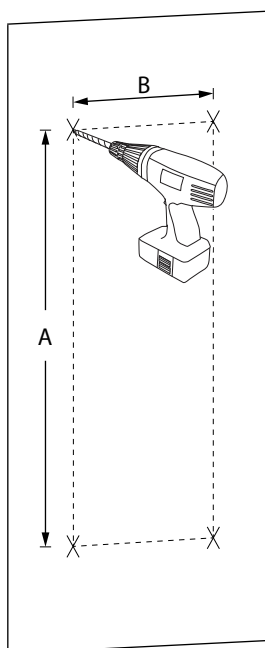

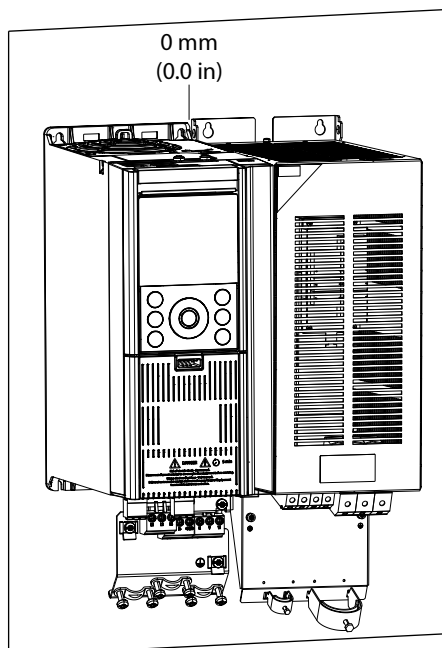
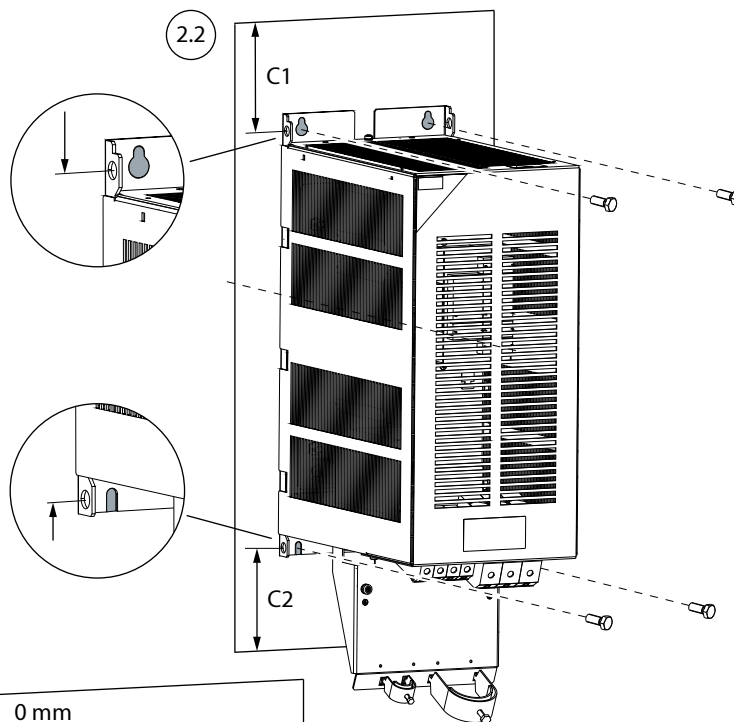

2.2



3 175U6006-175U6013

e30bl632.10

175U6006	U1, V1, W1, R+	1.2-2.0 Nm (11-18 in-lb)
	U2, V2, W2	2.0-4.0 Nm (18-35 in-lb)
		6.0 Nm (53 in-lb)
175U6013	U1, V1, W1, R+	1.2-2.0 Nm (11-18 in-lb)
	U2, V2, W2	2.5-5.0 Nm (22-44 in-lb)
		6.0 Nm (53 in-lb)
 SL1 T30		

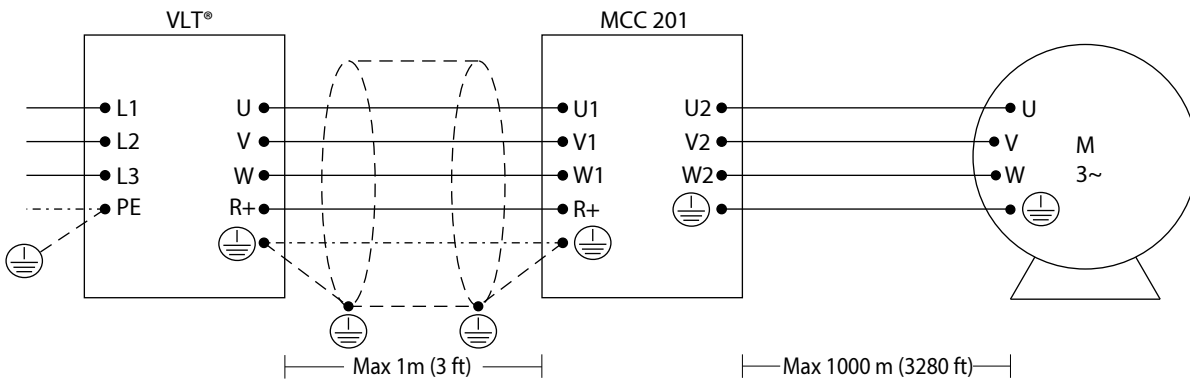
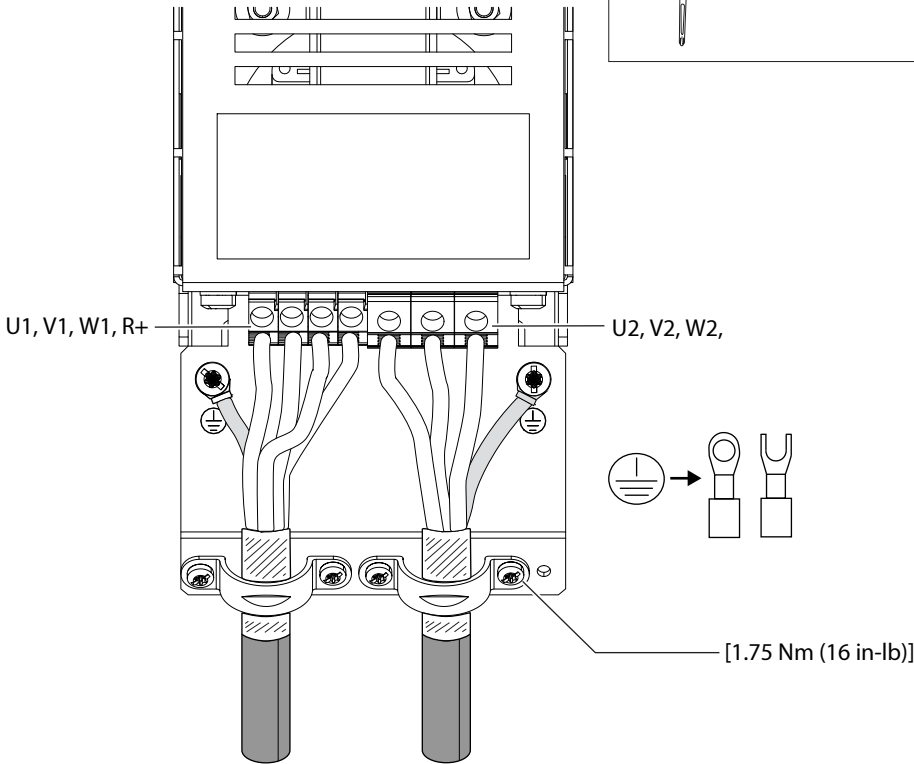

3 175U6024–175U6046–175U6065

e300633.10

175U6024	U1, V1, W1, R+	2.0–4.0 Nm (18–35 in-lb)
	U2, V2, W2	3.5–6.0 Nm (31–53 in-lb)
		6.0 Nm (53 in-lb)
175U6046	U1, V1, W1, R+	2.5–5.0 Nm (22–44 in-lb)
	U2, V2, W2	6.0–12.0 Nm (53–106 in-lb)
		6.0 Nm (53 in-lb)
175U6065	U1, V1, W1, R+	3.5–6.0 Nm (31–53 in-lb)
	U2, V2, W2	12.0–20.0 Nm (106–177 in-lb)
		6.0 Nm (53 in-lb)

SL1
 T30 10 mm

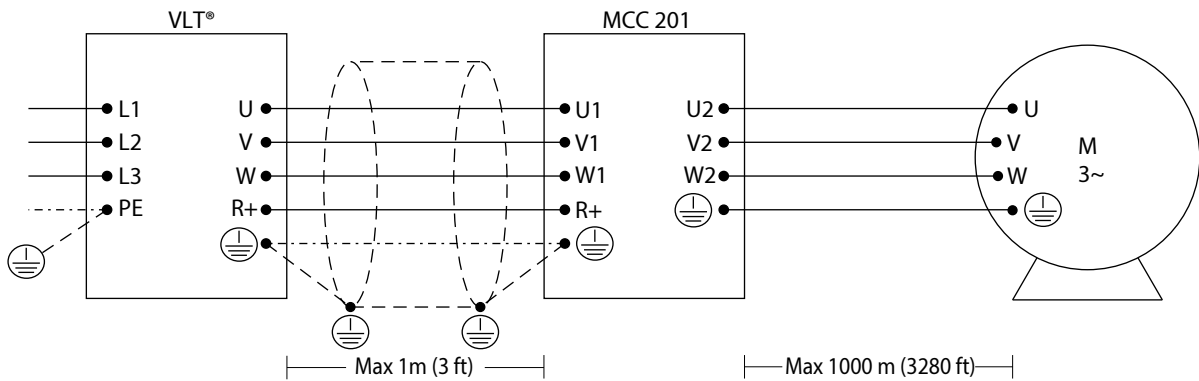
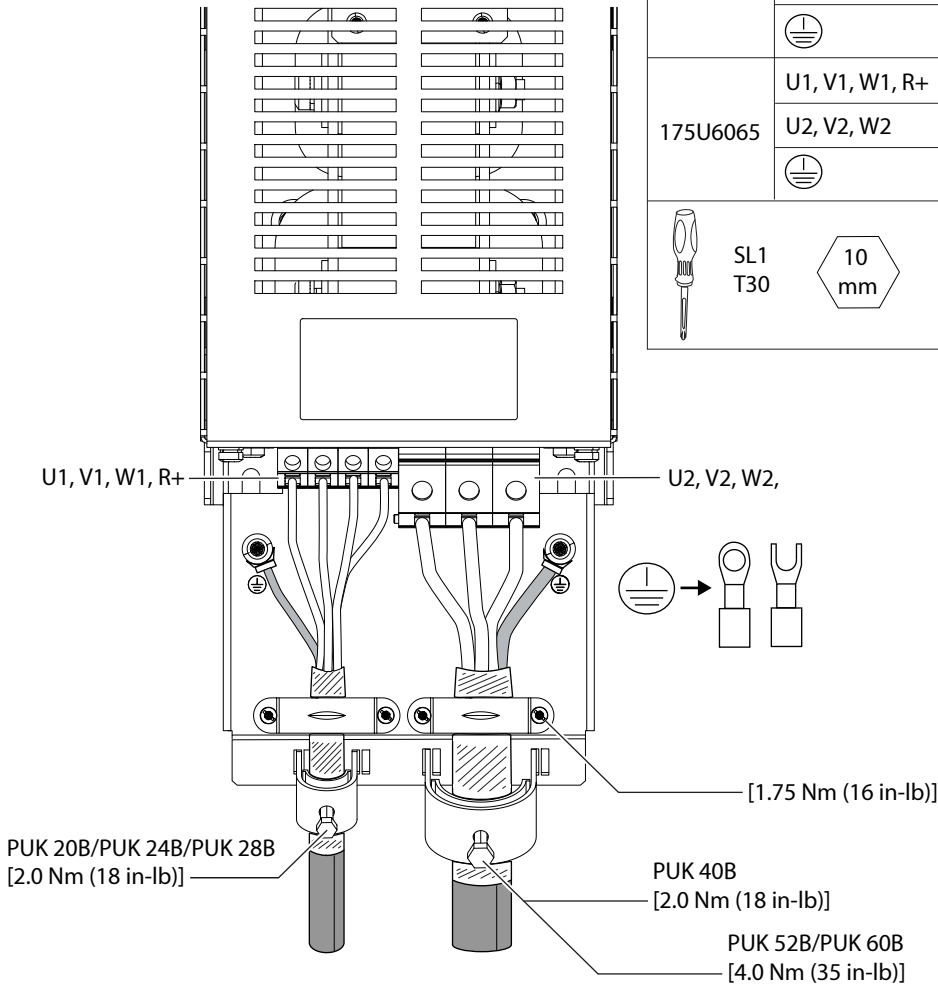

Danfoss A/S
Ulsnaes 1
DK-6300 Graasten
drives.danfoss.com

.....
Any information, including, but not limited to information on selection of product, its application or use, product design, weight, dimensions, capacity or any other technical data in product manuals, catalog descriptions, advertisements, etc. and whether made available in writing, orally, electronically, online or via download, shall be considered informative, and is only binding if and to the extent, explicit reference is made in a quotation or order confirmation. Danfoss cannot accept any responsibility for possible errors in catalogs, brochures, videos and other material. Danfoss reserves the right to alter its products without notice. This also applies to products ordered but not delivered provided that such alterations can be made without changes to form, fit or function of the product. All trademarks in this material are property of Danfoss A/S or Danfoss group companies. Danfoss and the Danfoss logo are trademarks of Danfoss A/S. All rights reserved.
.....

M00447

