

Disassembly Tool Program 0813

Order No.:
08-V015-0493



Risk of injury due to crushing of skin and limbs!

There is a risk of crushing of skin and limbs due to

- Spring force/gravity (stored energy).
- Falling conductor rail system components, if they have not been properly installed or if operated under inappropriate operating conditions (e.g., environment that contains solvents).

- Only allow installation to be conducted by specialized technicians.
- Wear personal protective equipment!



Further information on the installation of the conductor rail system can be found in the operating instructions BAL0813-0007!

The disassembly tool consists of two tools and is an aid for removing a hanger clamp from the conductor rail. Tool 1 is pushed between the hanger clamp and conductor rail, while Tool 2 opens the hanger clamp.

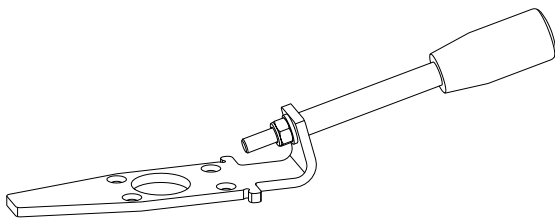

Fig. 1: Tool 1

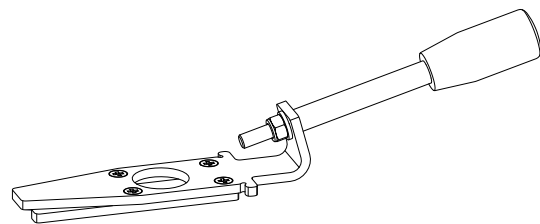

Fig. 2: Tool 2

- Slide Tool 1 up to the stopper between the conductor rail and hanger clamp (see Fig. 3).
- Press the conductor rail against Tool 1 or against the hanger clamp, respectively (see Fig. 4). At the same time, insert Tool 2 on the open side of the conductor rail (see Fig. 6). The retaining clamp of the hanger clamp bends up (see Fig. 5).

Disassembly Tool

Program 0813

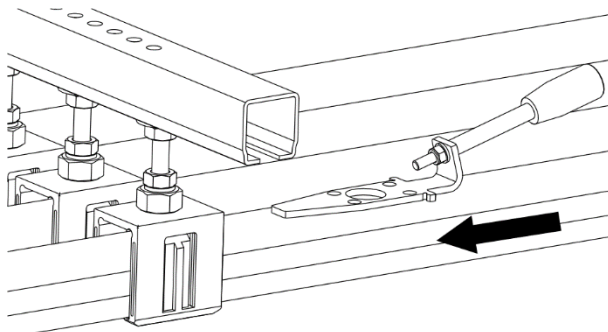

Fig. 3: Slide Tool 1 between the conductor rail and the hanger clamp

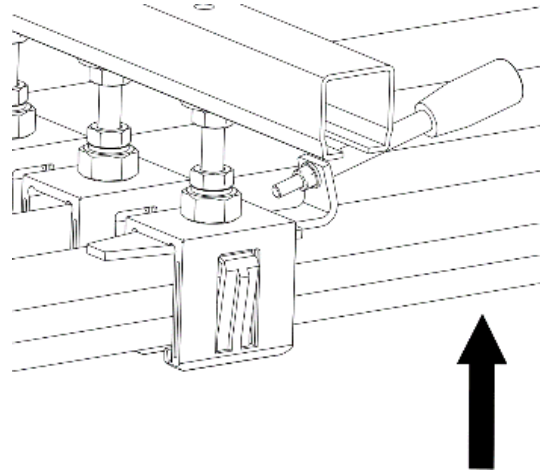

Fig. 4: Press the conductor rail against Tool 1 or against the hanger clamp

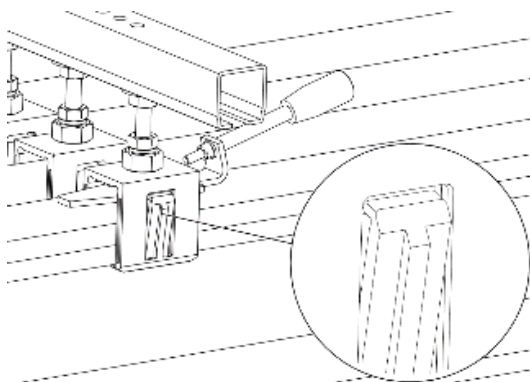

Fig. 5: The retaining clamp of the hanger clamp bends up

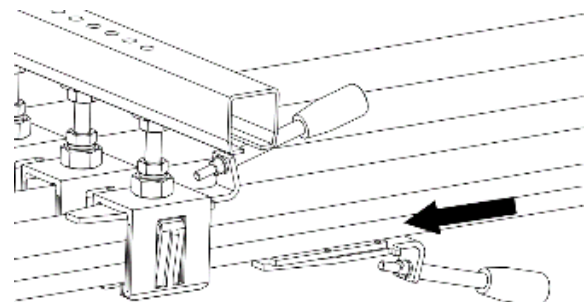

Fig. 6: Insert Tool 2 on the open side of the conductor rail

- Pull out the conductor rail.
- Remove Tool 2 from the open side of the conductor rail (see Fig. 8).

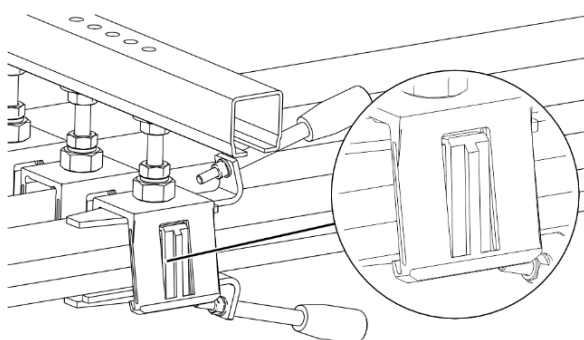

Fig. 7: The hanger clamp bends up

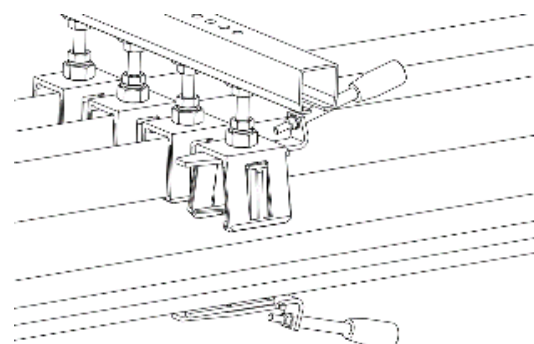

Fig. 8: Remove Tool 2 from the open side of the conductor rail

Installation Instructions



Disassembly Tool Program 0813

→ In order to remove Tool 1, the tension spring of the retaining clamp may need to be pushed away.

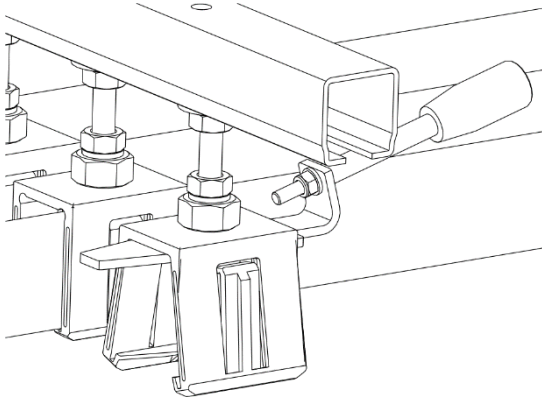

Fig. 9: Remove Tool 1



Use the QR code ("click" or "scan") to see our animation **Disassembly Tool**.

Conductix-Wampfler GmbH
Rheinstraße 27 + 33
79576 Weil am Rhein - Markt
Germany

Phone: +49 (0) 7621 662-0
Fax: +49 (0) 7621 662-144
info.de@conductix.com
www.conductix.com



Importer for the United Kingdom:
Conductix-Wampfler Ltd.
1, Michigan Avenue
Salford
M50 2GY
United Kingdom

Phone: +44 161 8480161
Fax: +44 161 8737017
info.uk@conductix.com
www.conductix.com