

Real Stone Tall Triple Fountain Kit Installation Manual



For use with
Tall Triple Stone Column Fountains
with Support Stands

Included in this Kit:

Blue Thumb makes installation of your triple column stone fountain kit easy by following these instructions.

Subscribe to our YouTube channel, **BlueThumbINC**, for related informational videos.



1a



1b

STEP 1

Choose Location for Basin

1a Locate your fountain near your preferred viewing area where both water and electricity services are accessible. Be certain to avoid underground utilities.

1b Clear the area and prepare to excavate by tracing the fountain basin using marking paint.

STEP 2

Excavation of Basin Area

2a Using a shovel dig 90 degrees into the ground, slightly wider and just as deep as the fountain basin making sure to remove any sharp rocks or roots.

2b NOTE: If installing a splash apron, make sure the basin is about 2" below grade, allowing you to slope the surrounding terrain toward the basin.

IMPORTANT Level the bottom of the hole across the entire basin, add sand or small gravel if needed. Tamp to ensure no settling occurs after installation. Check again to make sure the center is level with the edges.



2a



2b



Level



Tamp

STEP 3 Set Basin in Place

Position the basin within the hole. Make sure the pump opening in the grate is orientated near electrical service.

If installing the splash apron, set basin in the hole and verify that the basin top is level and approximately 2" below grade.



STEP 4 Level

Using a level, ensure the fountain basin remains level side to side. **The basin should sit solidly on the compacted and leveled ground below.** Hanging the lip of the basin on the surface can cause the basin center to buckle.



Optional Auto Fill Kit Install

If a Blue Thumb Elite Auto Fill Kit (Item: #ABDAUTO) is being incorporated, you will want to bury your water supply line and make any Auto Fill connections at this time.

STEP 5 Backfill

Backfill around the box and soil using excavated soil or self-compacting material, such as sand or pea gravel. When using excavated soil be sure to regularly compact with a tamper.

If your basin included a cardboard cover leave it in place while you backfill to prevent soil from falling into the basin.

Note: The more solid the soil is around and below the reservoir, the less shifting over time from settling and rain.



STEP 6 Important Before Filling your Basin

Once Achelous Basin is in place, clean basin area of any loose dirt.

Remove cardboard and vacuum out any dirt that may have fallen into the basin then wipe clean before adding water. Keep that pump happy with a clean basin full of clear water!

You may fill your basin with clean water at this point to stabilize the basin, or you may wait until your fountains are in place.

NOTE: Normal evaporation is about 1-2" weekly, however, that is dependent on your region. Many factors including humidity, rainfall, wind, and splash will determine exactly how frequently you need to refill.



Regarding Grate Orientation

The two halves of the grate may look nearly identical on the top and bottom, but be sure to identify the top side, which features a lip where the Pump Access Cover rests. The grate halves are designed to meet over two support columns, ensuring maximum strength. An additional PVC center support may be included for added stability.



STEP 7 Fountain Placement

If helpful, you may place grates and temporarily set fountains. The fountains can be as close together or as far apart as you like. We recommend a “Y” pattern using the elongated holes for best strength and stability.

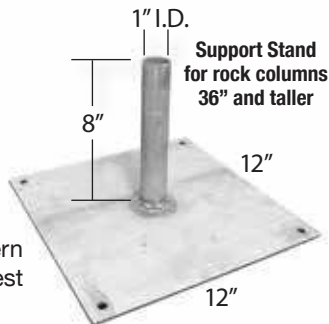

A Support Stand will come with any stone fountain 36” or taller. Note the length and width of the base plate when determining fountain spacing.



STEP 8 Basin Screen Prep

Lay the screen over the basin grates and cut holes in the screen according to your fountain positioning.



Tubing is in fixed lengths of 8', 7', and 5'. These lengths correspond to the height of the water features with the longest hose going to the tallest fountain.

STEP 9 Connect Pump Plumbing

On the Triton Assembly there are 3 barbed connectors with flow control valves. Two keys (red or blue) are used to adjust each individual fountain’s water flow.

9a Slide each 3/4” tubing onto a barbed connector keeping in mind the hose lengths and your chosen fountain orientation.

9b Attach 90° elbow Discharge Assembly to the pump.

9c Slide the Triton 3-way splitter valve with tubing onto the discharge assembly and tighten the hose clamps.

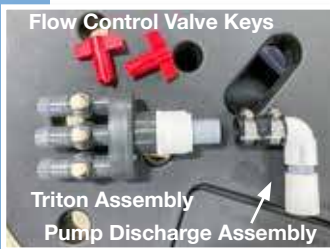

STEP 10

Install 1st Half of Grate and Place PVC Support

10a Lay grate/cover on the basin. It should sit firmly in the basin notch. Place the PVC Center support under this grate in the center of the basin. This support provides additional strength with heavier fountains and direct point loads.

10a Set pump assembly in the basin, notice how the tubing has room to curl around in the basin before being directed up through the grate.

10b Make sure the tubing has no kinks or twists, which can cause a reduction in water flow, and possibly no flow at all.



STEP 11

Pull Tubing and Place 2nd Half of Grate

Pull all three tubing pieces through the grate so they extend about 12" or so above the basin. Make sure the tubing sizes correlate to your chosen finished fountain column set up before placing the second grate half.



Put the screen over the tubing matching the holes you have cut as shown above.

At this point the stone fountain column installation will depend on if stand is needed (Steps 12A) and plume lights were purchased (Steps 12B).

12A Stone Column Installation Without Lighting

Placing Fountain Columns on Basin

12Aa If shorter than 36", the fountain will not need a support stand and the tubing will be slid up the fountain column without a stand, then follow directions with a stand.

12Ab If 36" or taller, the fountain column will need the provided support stand for added stability. Slide the stone column onto the stand.

12Ac Gently Lay stone column and stand on the basin with the base near the appropriate tubing length and close enough to stand directly over the tubing.

12Ad Feed the correct length of tubing from the bottom to the top of the column, ensuring that it extends 1-2 inches past the top. This extra length will make securing the tubing with the O-ring easier.



STEP 12A - Continued



12Ae Carefully stand the column upright, ensuring the hose is not pinched underneath. Any excess tubing can be fed back into the basin.

Repeat process with the remaining column fountains.

Secure Tubing with O-Ring on Each Fountain

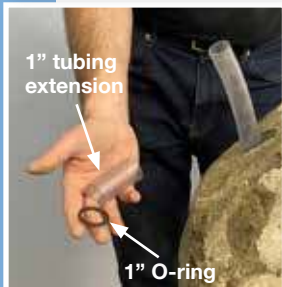

12Af Slide the 1" tubing extension over the 3/4" tubing. Making sure the tops are even.

12Ag Push excess tubing back into the basin so it sits just below the top of the fountain surface. The o-ring will hold the tubing in place.

12Ah Push excess tubing back into the basin so it sits just below the top of the fountain surface. The o-ring will hold the tubing in place. The tubing should just extend to the inside of the fountain without being visible.

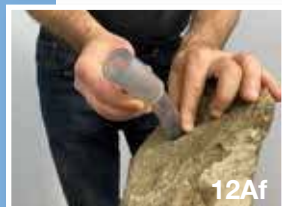

12B - Installation With Lighting Kit

Lighting Placement During Stand Installation

No O-ring or 1" extender is needed when a lighting kit is installed. The columns have been drilled to fit the Plume Lights perfectly. Follow these instruction to run light cords down the fountain and through the column stand.



12Ba Slide the stone column onto the stand. Slip the power end of the cord though the top of the fountain. You may feel the cord catch on the stand. Simply wiggle cord until it passes through.



12Bb Hold the light cord from top and bottom. Gently lay stone column and stand on the basin with the base near the appropriate tubing length and close enough to stand directly over the tubing.



12Bc While holding the light cord, feed the correct length of tubing from the bottom to the top of the column, ensuring that it extends 1-2 inches past the top.

12Bd Carefully stand the column upright, ensuring the hose is not pinched underneath.

12Be Pull excess Light Cord and lay on the grate screen.

12Bf Connect tubing firmly to the Barbed Connector.

12Bg Gently press light and excess tubing into fountain so the light sits just below opening.

12Bh At the fountain base, pull the Light Cords and lay on top of the grate screen. Direct cords to the Splitter (See light kit for detailed lighting instructions.) Repeat with other two fountains.

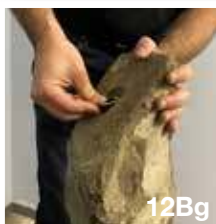

Step 13

Testing & Flow Adjustment

13a If you haven't already added water to the fountain basin, add water until the basin is filled to the bottom of the grates. Plug in the pump cord to test your fountain.



Set the water flow and plume height by adjusting the valves with the provided red valve key attached to your pump assembly. Use the included plastic shims to level the fountains for even water flow over the columns.

Splash should be kept to a minimum to avoid excessive refilling. Our optional Auto Fill Kit, (ABDAUTO) is used to keep the water level topped off with minimal maintenance checks.

13b Note: Although not entirely necessary, for added security the stand plate may be screwed into the basin cover. Screws are not included in this kit.



Step 14

Landscape Finish

Cover your basin with Polished Pebbles and surround with your favorite foliage. Avoid placing soil or bark on the grate because it may fall through the screen into the basin and affect water flow.

Note: Shims are included to help stabilize your fountains if needed. This is especially useful when lighting is installed, as the fountains may sit unevenly on the light cords. Simply adjust with the shims to ensure a level and secure placement.

ENJOY! We'd love for you to share your new fountain with us and future customers on our social media platforms!



Maintenance

General Fountain and System Maintenance

- It is OK to run pump continuously 24/7, or you may choose to connect it to a timer.
- Regularly check the water level in the basin. Never allow the water to drop below the pump, as this can lead to pump failure.
- Fill evaporated water as necessary or considering installing an Auto Fill Kit #ABDAUTO.
- Add Muck Buster® #PB2682 every couple of weeks to the basin to ensure muck doesn't build-up over time and clog the pump. 3 tablets treat 500 gallons of water.
- If algae forms on columns, brush off and use Crystal Clear® Algae D-Solv® #PB2002 to quickly clear organic debris and remove odors. 1 ounce treats 360 gallons.



Auto Fill Kit
#ABDAUTO



Muck Buster®
#PB2682



Algae D-Solv®
#PB2002

Winterizing:

- If you live in a climate that experiences prolonged freezing conditions, we recommend removing the pump from the basin. Place the pump in a bucket of water and store it in a place that will not freeze.
- Do not drain the basin during the winter months - allow the water to freeze in the basin so that the ground doesn't cause the basin to rise or "pop up" from expansion of the freezing soil around it.
- Our Rock Columns are manufactured to withstand freezing conditions and can be left outside during the winter months. There is no need to cover the Rock Columns, but you may do so if you desire.

Spring Start-Up:

- Once everything has thawed in the spring we recommend draining the water in the basin and replacing it with fresh, clean water. A wet/dry vacuum works well for removing water and accumulated debris.
- Reconnect the pump and plug it in.
- Add Muck Buster® to remove any remaining muck that was not able to be removed manually.

If you need replacement parts please contact us directly at **888-619-3474** or email us at sales@bluethumbponds.com.

Now, snap a picture of your completed waterfall and post it to our Facebook page at facebook.com/bluethumbinc/!

www.shopbluethumb.com

