

Installation Guide

Avigilon H4 PTZ Camera with IR Models:

1.0C-H4IRPTZ-DP45, 1.0C-H4IRPTZ-DP45-WP, 2.0C-H4IRPTZ-DP30 and 2.0C-H4IRPTZ-DP30-WP

Important Safety Information

This manual provides installation and operation information and precautions for the use of this device. Incorrect installation could cause an unexpected fault. Before installing this equipment read this manual carefully. Please provide this manual to the owner of the equipment for future reference.



This Warning symbol indicates the presence of dangerous voltage within and outside the product enclosure that may result in a risk of electric shock, serious injury or death to persons if proper precautions are not followed.



This Caution symbol alerts the user to the presence of hazards that may cause minor or moderate injury to persons, damage to property or damage to the product itself if proper precautions are not followed.



WARNING — Failure to observe the following instructions may result in severe injury or death.

- This product should be installed by a trained professional and should be installed in restricted access locations.
- This product is intended to be supplied by a UL Listed Power Unit marked “Class 2” or “LPS” or “Limited Power Source” with output rated 24VAC±10%, 105 VA min.; 24VDC±10%, 75 W min. or a Microsemi PD-9601G/AC Power over Ethernet (PoE) mid-span injector.
- Any external power supply connected to this product may only be connected to another Avigilon product of the same model series. External power connections must be properly insulated.
- Do not connect directly to mains power for any reason.
- This product is intended to be used in a Network Environment 0 per IEC TR62101. The camera is to be connected only to PoE networks that comply with IEEE 802.3at without routing to the outside plants.



CAUTION — Failure to observe the following instructions may result in injury to persons or damage to the device.

- Do not install near any heat sources such as radiators, heat registers, stoves, or other sources of heat.
- Do not subject the device cables to excessive stress, heavy loads or pinching.
- Refer all device servicing to qualified personnel. Servicing may be required when the device has been damaged (such as from a liquid spill or fallen objects), does not operate normally, or has been dropped.
- Do not use strong or abrasive detergents when cleaning the device body.
- Use only accessories recommended by Avigilon.
- This product should be installed in restricted access locations.

- **Risk Group 1. NOTICE:** IR emitted from this product. Use appropriate shielding or eye protection.

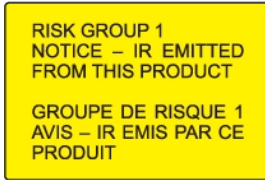

Regulatory Notices

This device complies with part 15 of the FCC Rules. Operation is subject to the following two conditions: (1) this device may not cause harmful interference, and (2) this device must accept any interference received, including interference that may cause undesired operation.

This Class B digital apparatus complies with Canadian ICES-003.

This equipment has been tested and found to comply with the limits for a Class B digital device, pursuant to Part 15 of the FCC rules. These limits are designed to provide reasonable protection against harmful interference in a residential installation. This equipment generates, uses and can radiate radio frequency energy and, if not installed and used in accordance with the instructions, may cause harmful interference to radio communications. However, there is no guarantee that interference will not occur in a particular installation. If this equipment does cause harmful interference to radio or television reception, which can be determined by turning the equipment off and on, the user is encouraged to try to correct the interference by one or more of the following measures:

- Reorient or relocate the receiving antenna.
- Increase the separation between the equipment and the receiver.
- Connect the equipment into an outlet on a circuit different from that to which the receiver is connected.
- Consult the dealer or an experienced radio/TV technician for help.

Changes or modifications made to this equipment not expressly approved by Avigilon Corporation or parties authorized by Avigilon Corporation could void the user's authority to operate this equipment.

To meet the requirements of the EN 50121-4 Railway Applications Standard, use an external power supply or POE injector that is also compliant with EN 50121-4. Please contact Avigilon for assistance regarding supporting equipment.

Disposal and Recycling Information

When this product has reached the end of its useful life, please dispose of it according to your local environmental laws and guidelines.

Risk of fire, explosion, and burns. Do not disassemble, crush, heat above 100 °C (212 °F), or incinerate.

European Union:



This symbol means that according to local laws and regulations your product should be disposed of separately from household waste. When this product reaches its end of life, take it to a collection point designated by local authorities. Some collection points accept products for free. The separate collection and recycling of your product at the time of disposal will help conserve natural resources and ensure that it is recycled in a manner that protects human health and the environment.

Legal Notices

© 2022, Avigilon Corporation. All rights reserved. AVIGILON, the AVIGILON logo, AVIGILON CONTROL CENTER, and ACC are trademarks of Avigilon Corporation. ONVIF is a trademark of Onvif, Inc. Other names or logos mentioned herein may be the trademarks of their respective owners. The absence of the symbols ™ and ® in proximity to each trademark in this document or at all is not a disclaimer of ownership of the related trademark. Avigilon Corporation protects its innovations with patents issued in the United States of America and other jurisdictions worldwide (see [avigilon.com/patents](https://www.avigilon.com/patents)). Unless stated explicitly and in writing, no license is granted with respect to any copyright, industrial design, trademark, patent or other intellectual property rights of Avigilon Corporation or its licensors.

Disclaimer

This document has been compiled and published using product descriptions and specifications available at the time of publication. The contents of this document and the specifications of the products discussed herein are subject to change without notice. Avigilon Corporation reserves the right to make any such changes without notice. Neither Avigilon Corporation nor any of its affiliated companies: (1) guarantees the completeness or accuracy of the information contained in this document; or (2) is responsible for your use of, or reliance on, the information. Avigilon Corporation shall not be responsible for any losses or damages (including consequential damages) caused by reliance on the information presented herein.

Avigilon Corporation
avigilon.com

PDF-H4IRPTZ-DP-A

Revision: 6 - EN

20220422

Table of Contents

Overview	1
Rear View	1
Front View	2
Top View	3
Pendant Wall Mount View	4
NPT Mount View	5
Installation	6
Package Contents	6
Installation Steps	6
Installing the Mounting Adapter	6
Installing the Pendant Wall Mount	7
Installing the NPT Mount	8
Connecting Cables	10
Securing the PTZ Camera	15
(Optional) Configuring microSD Card Storage	16
Initializing a Camera Username and Password	16
Assigning an IP Address	17
Accessing the Live Video Stream	18
For More Information	18
Connecting to Power and External Devices	20
Setting the Home Preset Position	22
Manually Returning to the Home Position	22
Automatically Returning to the Home Position	22
Connection Status LED Indicator	24
Troubleshooting Network Connections and LED Behavior	24
Resetting to Factory Default Settings	26
Setting the IP Address Using the ARP/Ping Method	27
Cleaning	28
Lens and IR Window	28
Body	28
Troubleshooting	29
Video Does Not Display After Powering the Camera	29
Specifications	30

Limited Warranty and Technical Support 32

Overview

Rear View

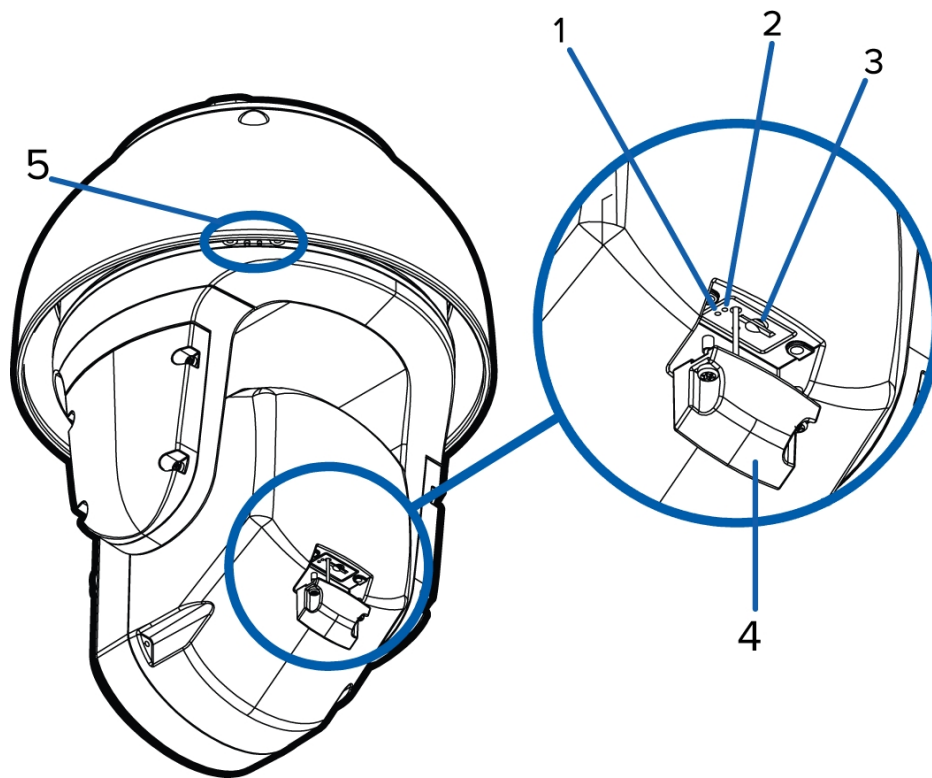

1. **Link LED indicator**

Amber LED indicates if there is an active connection in the Ethernet port.

2. **Connection status LED indicator**

Green LED provides information about device operation. For more information, see *Connection Status LED Indicator* on page 24.

3. **microSD card slot**

Accepts a microSD card for onboard storage. For more information, see *(Optional) Configuring microSD Card Storage* on page 16.

4. **microSD cover**

Protective cover for the microSD card slot. Uses tamper resistant screws to secure the cover.

5. **Sprayer mounting location**

(Available on -WP models only.) An optional washer can be mounted at this location for cleaning the lens and IR window. Connect digital output 1 from the camera to the washer pump. This will allow the camera WebUI or Avigilon Control Center to activate the washer whenever a washing sequence is initiated. For more information, please refer to the Camera WebUI guide. The washer and cleaning liquid are sold separately.

Install the sprayer mounting bracket by tightening the provided screws into this location.

Front View

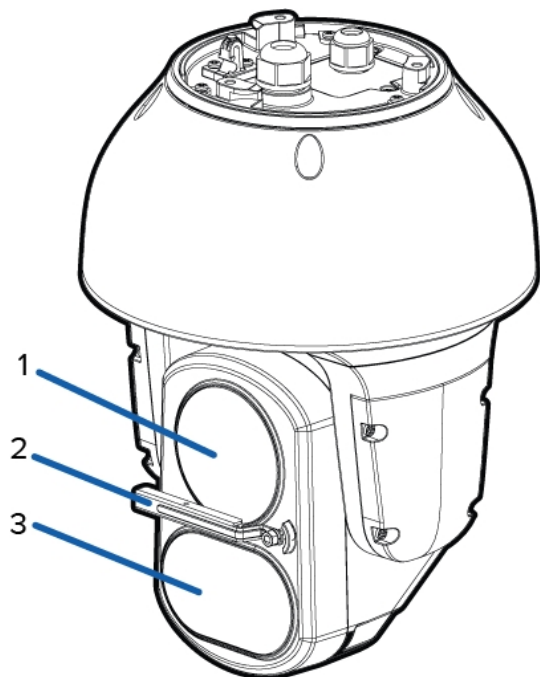

- 1. Lens**
The camera lens is housed behind a protective window.
- 2. Wiper**
(Available on -WP models only) Wiper rotates 90° in both directions to clean both lens and IR window.
- 3. Variable IR Illuminators**
High powered infrared LEDs with variable field of view to accommodate different low light situations.
The IR illuminators are housed behind a protective window.

Top View

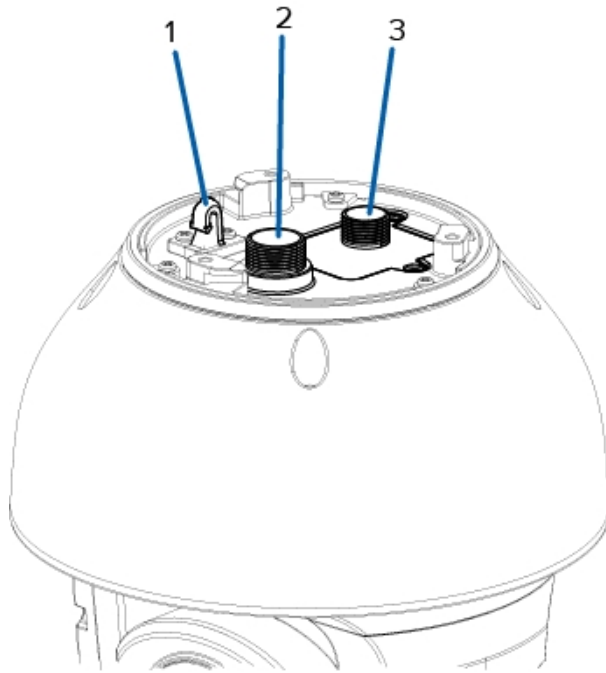

1. **Lanyard anchor**

The safety lanyard attaches to the anchor to prevent the camera from falling during installation.

2. **Ethernet port**

Accepts an Ethernet connection to a network. Server communication and image data transmission occurs over this connection. Also receives power when it is connected to a network that provides Power over Ethernet.

3. **Power and I/O cables**

Cables for connecting the camera to auxiliary power and I/O devices. For more information, see *Connecting to Power and External Devices* on page 20.

Pendant Wall Mount View

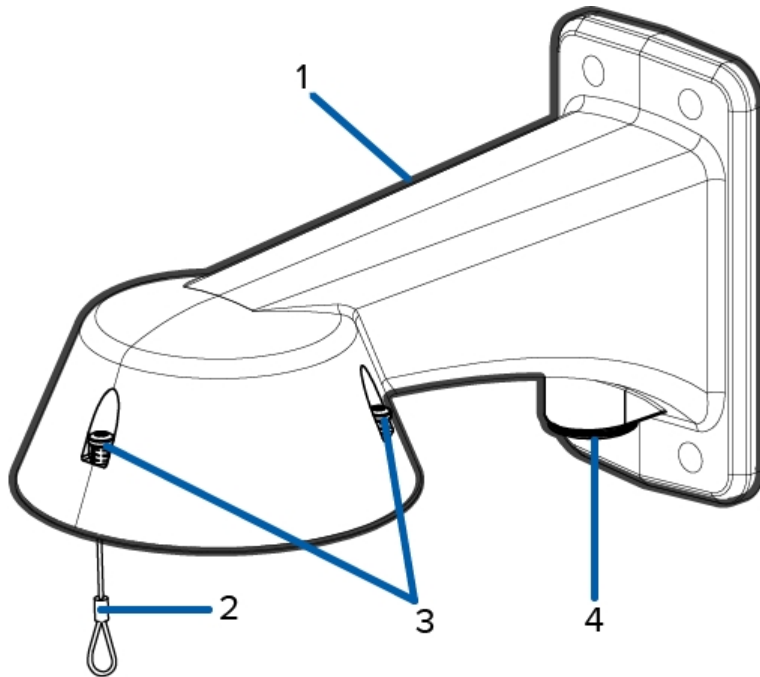

- 1. Pendant wall mount**
Camera mount for walls and other mounting surfaces.
- 2. Lanyard**
Connects to the lanyard anchor on the camera base.
- 3. Tamper resistant screws**
Star captive screws to fix the dome camera to the mounting adapter.
- 4. NPT pipe entry hole**
A 3/4" NPT threaded hole for NPT pipe conduits.

NPT Mount View

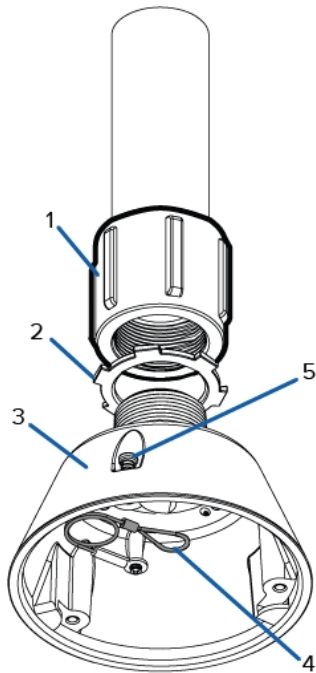

1. **1-1/2" NPT-female to NPT-female adapter**

An adapter for attaching the pendant NPT mount to an NPT pipe.

Note: The adapter is not an included accessory supplied by Avigilon and should be sourced separately.

2. **Lock nut**

Locking nut for securing the pendant NPT mount on the NPT-female to NPT-female adapter.

3. **Pendant NPT mount**

Dome camera mount for NPT pipes.

4. **Lanyard**

Connects to the lanyard anchor on the camera base.

5. **Tamper resistant screws**

Star captive screws to fix the dome camera to the mounting adapter.

Installation

Package Contents

Note: The pendant wall mount and pendant NPT mount are sold separately.

Ensure the camera package contains the following:

- Avigilon H4 IR PTZ Camera
- T20 star key
- T10 star key
- 3 x RJ-45 crimp-on plug
- External power and I/O wiring harness
- Sprayer mounting bracket and installation screws (only for models with wiper)

If you are installing the camera with the pendant wall mount, ensure the package includes the following:

- Pendant wall mount (H4IRPTZ-MT-WALL1)
- Mounting template sticker

If you are installing the camera with the NPT mount, ensure the package includes the following:

- NPT mount (H4IRPTZ-MT-NPTA1)
- Lock nut
- Thread sealing tape

Installation Steps

Complete the following sections to install the device.

Installing the Mounting Adapter

The PTZ camera can only be mounted to a pendant wall mount (IRPTZ-MNT-WALL1) or a pendant NPT mount (IRPTZ-MNT-NPTA1). The mounts are sold separately.

Use the pendant wall mount if you will be mounting the camera to a vertical mounting surface such as a wall.

Use the pendant NPT mount if you will be mounting the camera to a 1-1/2" NPT pipe for a free hanging installation.

Installing the Pendant Wall Mount

1. Determine where the cables will enter the pendant wall mount.
 - If the cables will be pulled from inside the mounting surface, use the cable entry hole at the rear of the pendant wall mount.
 - If the cables will be coming out of an external conduit pipe, use the 3/4" NPT pipe entry hole on the bottom of the pendant wall mount.
2. Use the provided mounting template to drill four mounting holes into the mounting surface.
 - If you are using the rear cable entry hole, also drill the cable entry hole into the mounting surface.
3. Pull the required cables through the preferred cable entry hole on the pendant wall mount.
 - If you are using the pipe entry hole, pull the cables through the pipe conduit then the wall mount. Next, apply thread seal tape to the pipe conduit and screw it into the pipe entry hole.

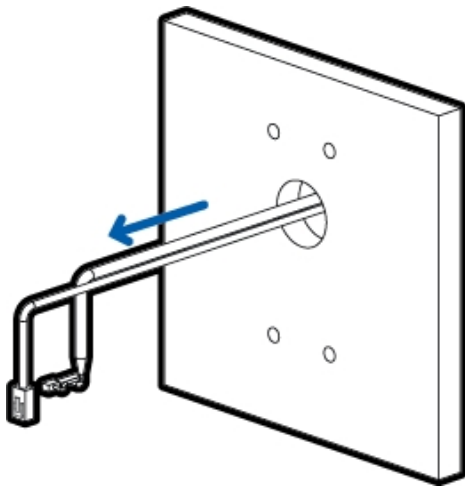

Figure 1: Cables pulled from the back entry hole.

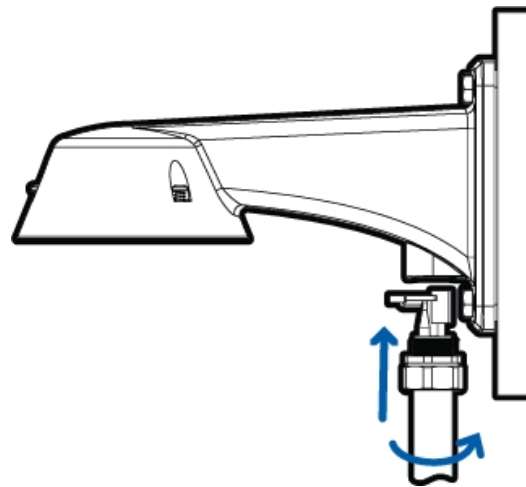
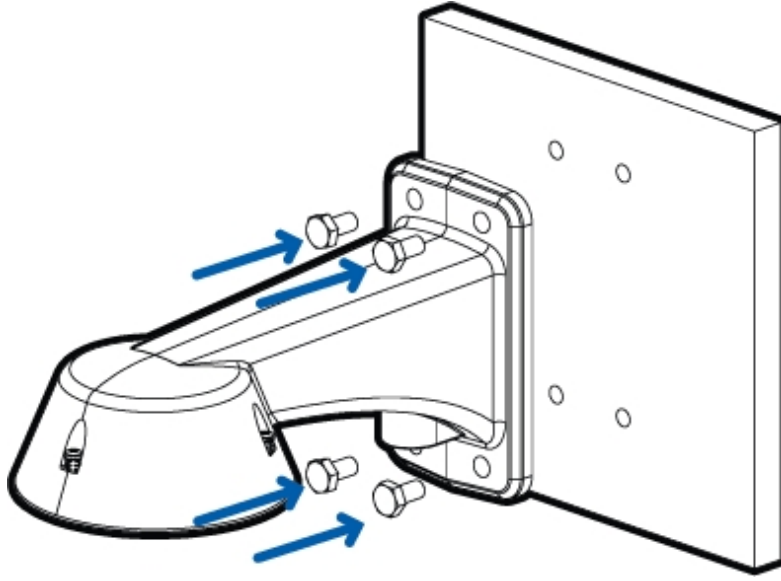
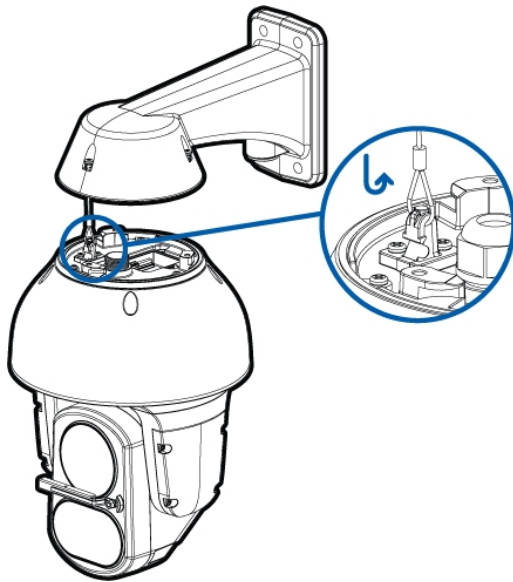

Figure 2: Cables pulled from the conduit entry hole.

4. Fasten the pendant wall mount to the mounting surface.



5. Tighten the wall mount screws to secure the wall mount to the wall.
6. Connect the safety lanyard from inside the wall mount to the anchor on the PTZ camera.



Installing the NPT Mount

Note: This procedure requires a 1-1/2" NPT-female to NPT-female pipe adapter. It is recommended that the NPT adapter be mounted to a 1-1/2" conduit pipe.

1. Pull the required cable through the NPT conduit pipe.
2. Apply thread seal tape to the pipe and screw on the 1-1/2" NPT female to NPT female pipe adapter.
3. Screw the lock nut onto the NPT adapter.
4. Apply thread seal tape to the NPT adapter and screw it into the pipe adapter.

Make sure the parts are assembled in this order from NPT conduit pipe to camera adapter:

- a. NPT conduit pipe
- b. 1-1/2" NPT female to female pipe adapter
- c. Lock nut
- d. NPT adapter

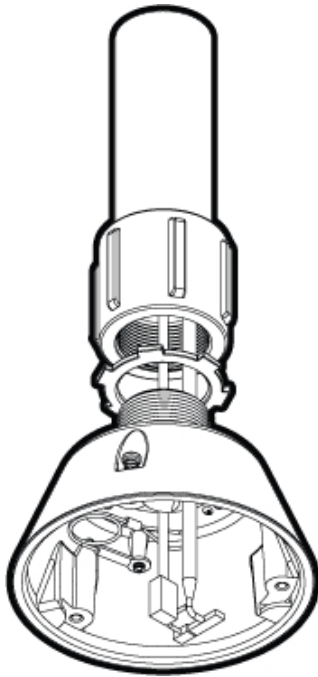

5. Connect the safety lanyard from inside the NPT mount to the anchor on the PTZ camera.

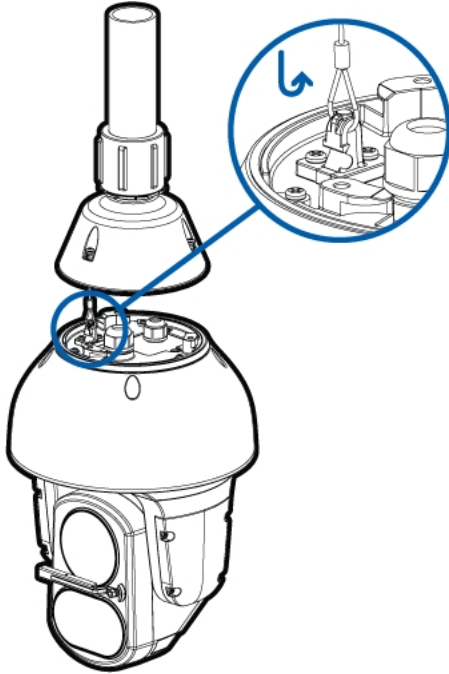

Connecting Cables

Refer to the diagrams in the Overview section for the location of the different connectors.

To connect the cables required for proper operation, complete the following:

Note: The PTZ camera does not support cables with boots and strain reliefs.

1. Make sure the safety lanyard is connected to the camera.
2. Remove the sealing gland caps from the top of the camera.

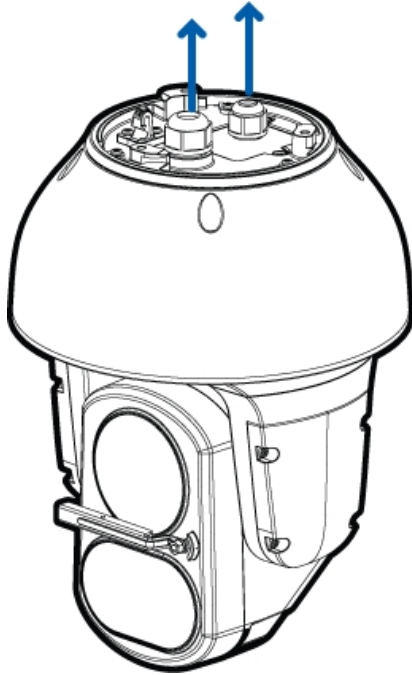

3. If there are external input or output devices that need to be connected to the camera (for example: door contacts, relays, analog video, speakers, etc.), connect the devices to the camera I/O connector cable.
4. Connect power using one of the following methods:
 - 95 W PoE Injector (POE-INJ2-95W) — Connect an Ethernet network cable to the injector.
 - 60 W PoE Injector (POE-INJ2-60W) — Connect an Ethernet network cable to the injector.
 - Cisco® UPoE capable switch, supporting 60 W over 4 pairs. Note that the Cisco switch must be configured with the *Force Four Pair* option enabled.
 - External Power — Connect a 24 V DC or 24 V AC (RMS) auxiliary power source that supports up to 75 W or 105 VA.

For more information, see *Connecting to Power and External Devices* on page 20.

5. Thread the Ethernet cable into the cable gland.
 - a. Drill a hole through the center of the provided cable gland that is slightly smaller in diameter than the Ethernet cable.

Do not cut or slice the cable gland. This may make it possible for water to enter the camera, and could void the warranty.

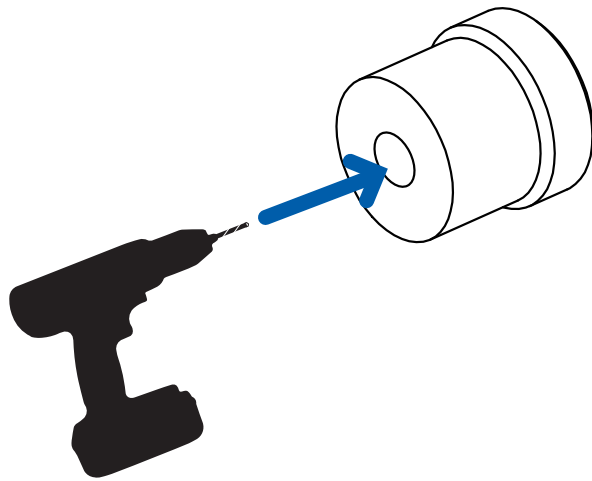

- b. Push the cable through the gland cap, and then the hole in the cable gland. Ensure the orientation of the cable and cable gland matches the following image.

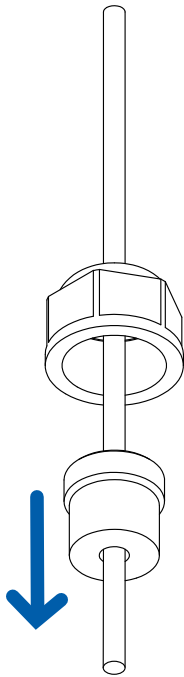

- c. Crimp the connector onto the Ethernet cable.

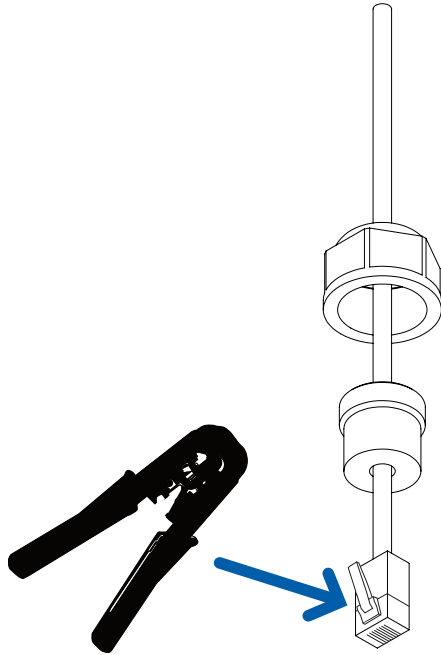

6. Remove the I/O cover and feed the I/O connector cable through the gland cap, cable gland, and I/O cover.

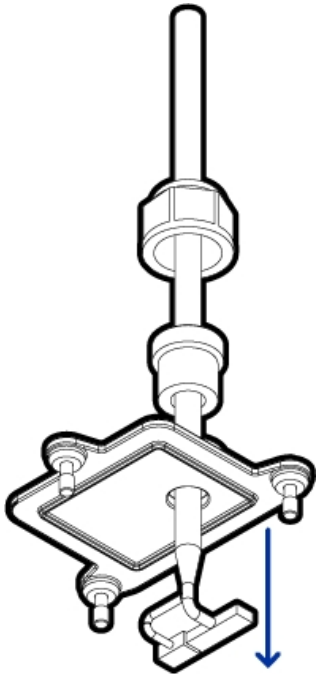

7. Tighten the cable glands around the cables.

8. Connect power and I/O to the camera, then tighten the I/O cover.

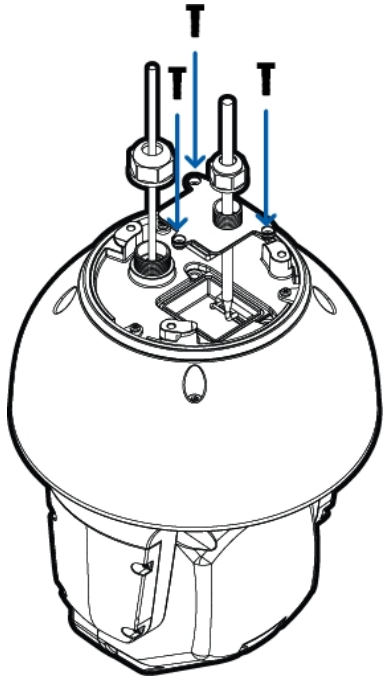

9. Connect a network cable to the Ethernet port (RJ-45 connector).

The Link LED indicator will turn on once a network link has been established.

Note: If you need to remove the RJ45 connector from the camera to check a network issue, gently pull the cable towards the locking tab to release the RJ45 plug before pulling upwards.

10. Check that the Connection Status LED indicator indicates the correct state. For more information, see *Connection Status LED Indicator* on page 24.

Securing the PTZ Camera

1. Push the PTZ camera into the mount adapter.

Note: Be careful not to trap any cables between the camera housing and the mount adapter.

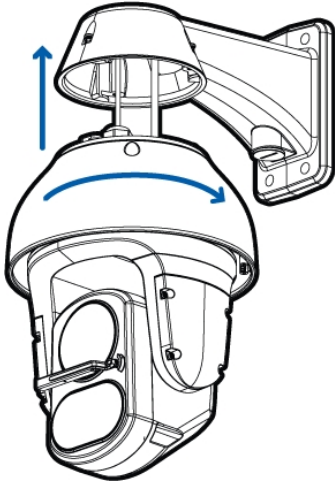

Figure 3: Pushing the camera into the wall mount adapter.

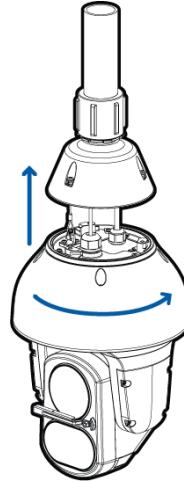

Figure 4: Pushing the camera into the NPT adapter.

Note: Once the camera housing is aligned to the adapter, turn the camera until it locks into place.

3. Use the T20 star key to tighten the screws in the mount adapter.

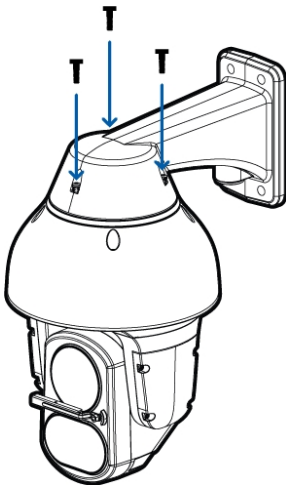

Figure 5: Securing the camera to the wall mount adapter.

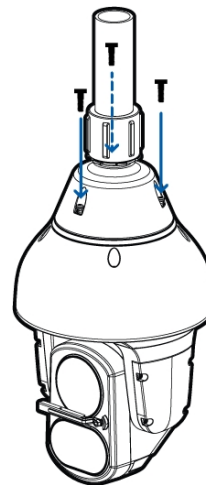
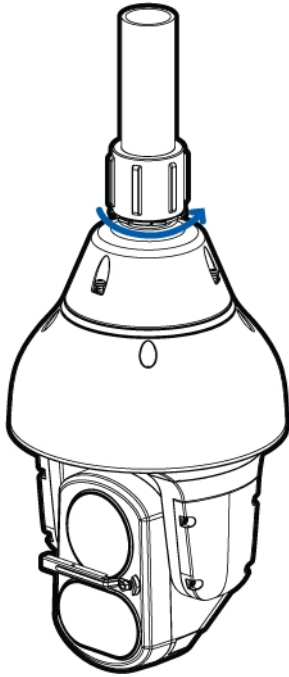

Figure 6: Securing the camera to the NPT adapter.

4. If you are installing the camera to an NPT mount, make sure the mount adapter is secured then tighten the lock nut to fix the camera to its final position.



(Optional) Configuring microSD Card Storage

To use the camera's microSD card storage feature, you must insert a microSD card into the card slot.

It is recommended that the microSD card have a capacity of 8 GB or more and a write speed of class 6 or better. If the SD card does not meet the recommended capacity or write speed, the recording performance may suffer and result in the loss of frames or footage.

1. Using the T10 star Key, unscrew and open the microSD cover at the rear of the camera.

For more information about the location of the rear cover and the microSD card slot, see *Rear View* on page 1.

2. Insert a microSD card into the camera.



CAUTION — Do not force the microSD card into the camera or you may damage the card and the camera.

3. Access the camera's web interface to enable the onboard storage feature. For more information, see the *Avigilon High Definition H.264 Camera Web Interface User Guide*.

Initializing a Camera Username and Password

Cameras manufactured after January 1, 2020, do not have a default username or password and will be in a factory default state.

Important: You must create a user with *administrator* privileges before the camera is operational.

The first user can be created using any of the following methods:

- Camera's Web Interface: enter the camera's IP address in a web browser to access the web interface. If the camera is in the factory default state you will be redirected to the Add a new user page to create the first user. For more information, see the *Avigilon High Definition H4 and H5 IP Camera Web Interface User Guide*.
- Camera Configuration Tool: cameras discovered in the factory default state will be identified by . Select the **Admin Users** tab to create the first user. For more information, see the *Avigilon Camera Configuration Tool User Guide*.
- USB Wi-Fi Adapter: when connecting a camera in the factory default state, you will be redirected to the Create Administrator User page to create the first user. For more information, see *Avigilon USB Wi-Fi Adapter System User Guide*.
- Avigilon Control Center software version 7.4 or later, or version 6.14.12 or later: when connecting a camera in the factory default state, the client software will ask you to create a new user. For more information, see the *Avigilon Control Center Client User Guide*.
- Avigilon Cloud Services (ACS) v3.0 or later: when adding a camera you will be asked to create a new user for cameras in the factory default state. For more information, see the *Avigilon Cloud Services User Guide*.

Tip: If you are connecting your Avigilon camera to a 3rd party VMS, you will need to set up the first user through the camera's Web Interface, USB Wifi Adapter, or Camera Configuration Tool before you connect to the 3rd party VMS.

Assigning an IP Address

The device automatically obtains an IP address when it is connected to a network.

Note: If the device cannot obtain an IP address from a DHCP server, it will use Zero Configuration Networking (Zeroconf) to choose an IP address. When set using Zeroconf, the IP address is in the 169.254.0.0/16 subnet.

The IP address settings can be changed using one of the following methods:

- Device's web browser interface: `http://<camera IP address>/`.
- Network Video Management software application (for example, the Avigilon Control Center™ software).
- ARP/Ping method. For more information, see *Setting the IP Address Using the ARP/Ping Method* on page 27.

Note:

Depending on the manufacture date of your camera, you will have one of the two options below to log in for the first time:

- Cameras manufactured after January 1, 2020: these cameras do not have a default username or password and will be in a factory default state. **You must create a user with *administrator* privileges before the camera is operational.** For more information, see *Initializing a Camera Username and Password* on page 16.
- Cameras manufactured before January 1, 2020: login to the camera using the default username of `administrator` with no password. It is recommended that you change the password after your first login.

Accessing the Live Video Stream

Live video stream can be viewed using one of the following methods:

- Web browser interface: `http://< camera IP address>/`.
- Network Video Management software application (for example, the Avigilon Control Center™ software).

Note:

Depending on the manufacture date of your camera, you will have one of the two options below to log in for the first time:

- Cameras manufactured after January 1, 2020: these cameras do not have a default username or password and will be in a factory default state. **You must create a user with *administrator* privileges before the camera is operational.** For more information, see *Initializing a Camera Username and Password* on page 16.
- Cameras manufactured before January 1, 2020: login to the camera using the default username of `administrator` with no password. It is recommended that you change the password after your first login.

For More Information

Additional information about setting up and using the device is available in the following guides:

- *Avigilon Control Center Client User Guide*
- *Web Interface User Guide — Avigilon High Definition H4 and H5 IP Cameras*
- *Avigilon Camera Configuration Tool User Guide*
- *Designing a Site with Avigilon Video Analytics*

These guides are available on help.avigilon.com and on the Avigilon website: avigilon.com/support.

Connecting to Power and External Devices

CAUTION — Be careful to only connect power to the Auxiliary Power Wires or the camera will be damaged.

If PoE is not available, the camera may be powered through the auxiliary power cable using either 24 V DC or 24 V AC. The power consumption information is listed in the product specifications.

To power the camera, connect the two power wires to the red and black auxiliary power wires. The connection can be made with either polarity.

WARNING — This product is intended to be powered by a UL Listed Power Unit marked “Class 2” or “LPS” or “Limited Power Source” with output rated 24 V AC +/- 10%, 105 VA min. or 24 V DC +/- 10%, 75 W min.

Power supplies and external devices are connected to the camera through the power and I/O wires. The pinout for the I/O and power wires is shown in the following diagram:

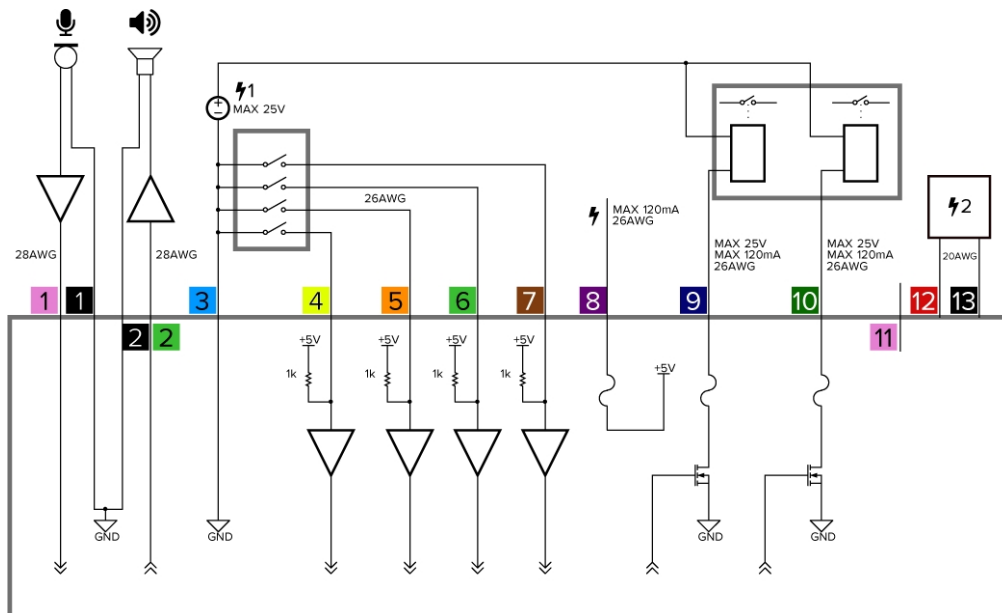

Figure 7: Example application.

1. Pink (AUDIO_IN) — Audio Input (line level)

An external power amplifier should be used when connecting speakers and microphones, as shown in the diagram.

1. Black — Audio Ground
2. Light Green (AUDIO_OUT)— Audio Output (line level)
 2. Black — Audio Ground
3. Light Blue (GND) — Ground for digital inputs and outputs.

4. Yellow (RI_1)— Digital Input, Relay 1. The input voltage must be below 0.7 V to register as a low input. The input voltage should not exceed 5 V when high.
5. Orange (RI_2)— Digital Input, Relay 2
6. Light Green (RI_3)— Digital Input, Relay 3
7. Brown (RI_4) — Digital Input, Relay 4
8. Purple (RO+)— +5V power output from camera. For the maximum allowable current, see *Specifications* on page 30.
9. Blue (RO_1) — Digital Output,
10. Green (RO_2) — Digital Output
11. Pink (Reserved) — Reserved Wire, do not connect.
12. Red (DC) — Auxiliary Power Wire, accepts DC and AC power.
13. Black (DC) — Auxiliary Power Wire, accepts DC and AC power.
 - ⚡ 1 — External relay power supply
 - ⚡ 2 — Optional 24 V AC (RMS) or 24 V DC Aux. power supply

Setting the Home Preset Position

The PTZ camera supports self-learning video analytics from the home preset position. The home preset position is typically the field of view the PTZ camera returns to after being used for investigations.

Before you can configure the camera's home position, you must connect the camera to a site in the ACC™ Client software. For more information about adding cameras to a site and the following steps, see the *Avigilon Control Center Client User Guide*.

To set the home preset position, display the live video from the PTZ camera then complete the following steps:

Tip: Name the preset position "Home" so that it will be easy to find when configuring the camera for other applications.

1. Move the camera's field of view into position.
2. In the **Presets** drop-down list, select a number then click .
3. In the dialog box, enter a name for the preset.
4. Select the **Set as home preset** checkbox if you want this to be the camera's Home preset.
5. Click **OK**.

After you've set the camera's home preset position, you can configure the required video analytics events in the ACC Client software.

Manually Returning to the Home Position

After the home preset position has been configured, you can set the PTZ camera to return to the configured field of view by clicking .

Automatically Returning to the Home Position

You can also configure the PTZ camera to automatically return to the home preset position after the camera is left idle for a set amount of time. This can be configured in two ways: through a PTZ tour or a rule.

A PTZ tour can be configured from the camera web interface or in the ACC Client software. To configure the PTZ camera to automatically return to the home position, create a new tour and add only the home position to the preset list. Next, select the **Set as default tour** checkbox and use the **Default Tour Idle Start Time (Minutes)** field to define the expected amount of idle time before the camera returns to the home position.

To use the rule method, you must have an Enterprise Edition or Standard Edition version of the Avigilon Control Center system. To configure the PTZ camera to automatically return to the home position, create a rule that includes the following settings:

- On the Select Rule Event(s) page, select **PTZ idle**.
- On the Select Rule Action(s) page, select **Go to Home Preset**.

Connection Status LED Indicator

Once connected to the network, the green Connection Status LED indicator will display the progress in connecting to the Network Video Management software.

The following table describes what the LED indicator shows:

Connection State	Connection Status LED Indicator	Description
Obtaining IP Address	One short flash every second	Attempting to obtain an IP address.
Discoverable	Two short flashes every second	Obtained an IP address but not connected to the Network Video Management software.
Upgrading Firmware	Two short flashes and one long flash every second	Updating the firmware.
Connected	On	Connected to the Network Video Management software or an ACC™ Server. The default connected setting can be changed to Off using the camera's web user interface. For more information see the <i>Avigilon High Definition H4 and H5 IP Camera Web Interface User Guide</i> .

Troubleshooting Network Connections and LED Behavior

Note: For any of the below LED behaviors, ensure that the camera is getting power and is using a good network cable before trying another solution.

LED Behavior	Suggested Solution
Green LED is off and amber is on	Perform a factory reset of the camera using the physical firmware revert button. Resetting through the camera's web interface will not produce the desired result.
Both LEDs are off and the camera is not connected or streaming video	Check the General setup page in the camera's web interface to ensure the LEDs are not disabled. If the LEDs are not disabled, perform a factory reset of the camera using the physical firmware revert button. Resetting through the camera's web interface will not produce the desired result.

LED Behavior	Suggested Solution
Both LEDs are blinking several times at the same time, then pause and repeat the blinking	Perform a factory reset of the camera using the physical firmware revert button. Resetting through the camera's web interface will not produce the desired result.
A different LED blinking pattern than those described above	Perform a factory reset of the camera using the physical firmware revert button. Resetting through the camera's web interface will not produce the desired result.

Resetting to Factory Default Settings

If the device no longer functions as expected, you can choose to reset the device to its factory default settings.

Use the firmware revert button to reset the device. The firmware revert button is shown in the following diagram:

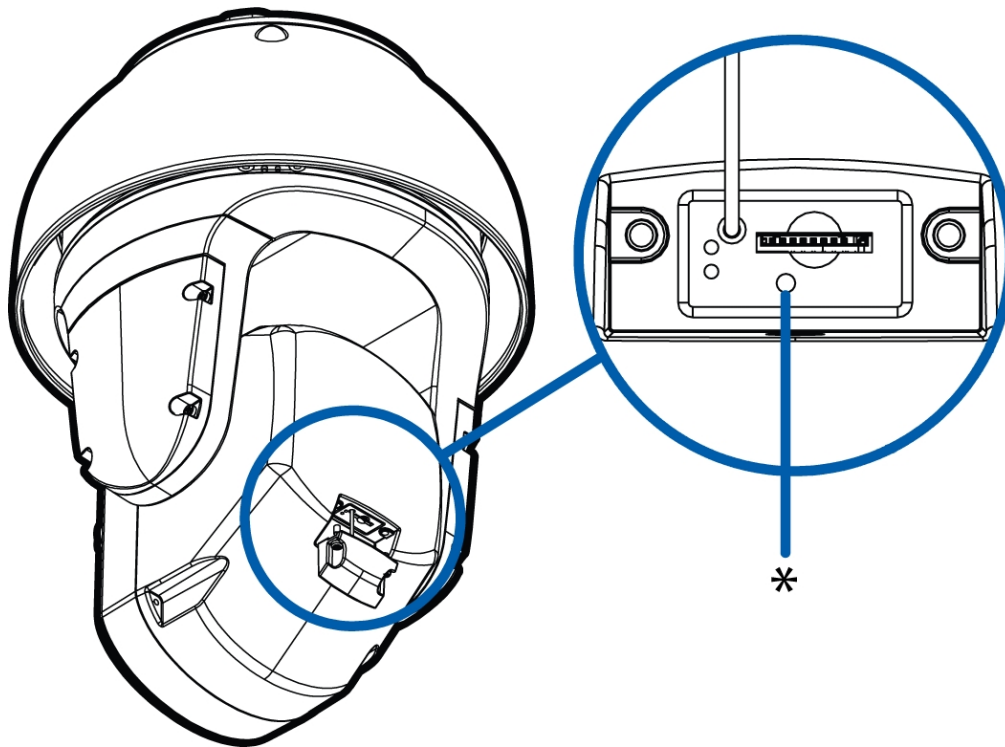

Figure 8: The firmware revert button below the SD card slot.

1. Ensure the camera is powered on.
2. Use the T10 star key to remove the SD cover.
3. Using a straightened paperclip or similar tool, gently press and hold the firmware revert button for two seconds.
4. Re-install the SD cover.



CAUTION — Do not apply excessive force. Inserting the tool too far may damage the camera.

Setting the IP Address Using the ARP/Ping Method

Complete the following steps to configure the camera to use a specific IP address:

Note: The ARP/Ping Method will not work if the **Disable setting static IP address through ARP/Ping method** checkbox is selected in the camera's web browser interface. For more information, see the *Avigilon High Definition H4 and H5 IP Camera Web Interface User Guide*.

1. Locate and make note of the MAC Address (MAC) listed on the Serial Number Tag for reference.
2. Open a Command Prompt window and enter the following commands:
 - a. `arp -s <New Camera IP Address> <Camera MAC Address>`
For example: `arp -s 192.168.1.10 00-18-85-12-45-78`
 - b. `ping -l 123 -t <New Camera IP Address>`
For example: `ping -l 123 -t 192.168.1.10`
3. Reboot the camera.
4. Close the Command Prompt window when you see the following message:
Reply from <New Camera IP Address>: ...

Cleaning

Lens and IR Window

If the video image becomes blurry or smudged in areas, it may be because the lens or IR window requires cleaning.

Note: Washer and cleaning liquid sold separately.

To clean the camera windows:

- In the camera web interface or video management software, activate the washer and wiper.
 - From the camera web interface, the washer and wiper can be activated from the Live View page. For more information, see the *Avigilon High Definition H.264 Web Interface User Guide*.
 - From the Avigilon Control Center software, the washer and wiper is activated through the PTZ auxiliary command. For more information, see the software help files.

If the cleanliness of the camera window continues to affect the imaging quality, or if you are maintaining a model that does not have a wiper, manually clean the camera windows as needed:

- Use hand soap or a non-abrasive detergent to wash off dirt or fingerprints.
- Use a microfiber cloth or non-abrasive fabric to dry the dome bubble.



CAUTION — Failure to use the recommended cleaning materials may result in a damaged or scratched camera window. A damaged camera window may negatively impact image quality and cause unwanted IR light reflecting into the lens.

Important: Failure to use the recommended cleaning materials may result in a damaged or scratched camera window. A damaged camera window may negatively impact image quality and cause unwanted IR light reflecting into the lens.

Body

- Use a dry or lightly dampened cloth to clean the camera body.
- Do not use strong or abrasive detergents.

Troubleshooting

Video Does Not Display After Powering the Camera

Note: The following troubleshooting case only applies to cameras that are powered up in a cold environment of -10°C to -40°C (14°F to -40°F) or lower. To properly power the camera at this lower temperature requires 95 W PoE or auxiliary power supply.

Up to a 60 minute startup delay may be necessary to warm up the camera when powering up in a cold environment below -10°C (14°F). During this cold start delay, video will not display and errors may be generated in ACC. If you are viewing video in the web interface you will see a blue screen and message about being in cold start mode. Video transmission will start and the errors will stop once the camera has warmed up.

Specifications

Camera

Lens	4.3 to 129mm, F/1.6 – F/4.7, autofocus
Audio Input/Output	Line level input and output
microSD Storage	microSD/microSDHC/microSDXC slot – minimum class 6; class 10/UHS-1 or better recommended

Network

Network	100Base-TX
Cabling Type	CAT5
Connector	RJ-45
API	ONVIF® compliant version 1.02, 2.00, Profile S (www.onvif.org) Compliant with version 2.2.0 of the Analytics Service Specification (bounding boxes and scene descriptions not available with third-party VMS)
Device Management Protocols	SNMP v2c SNMP v3
Security	Password protection, HTTPS encryption, digest authentication, WS authentication, user access log, 802.1x port based authentication.
Streaming Protocols	IPv4, HTTP, HTTPS, SOAP, DNS, NTP, RTSP, RTCP, RTP, TCP, UDP, IGMP, ICMP, DHCP, Zeroconf, ARP, RTP/UDP, RTP/UDP multicast, RTP/RTSP/TCP, RTP/RTSP/HTTP/TCP, RTP/RTSP/HTTPS/TCP, HTTP

Mechanical

Dimensions	Dome camera — (Ø) 250 mm x (H) 364 mm; (Ø) 9.84" x (H) 14.33" With wall mount — (W) 363 mm x (L) 250 mm x (H) 457 mm; (W) 14.29" x (L) 9.84" x (H) 17.99" With NPT mount — (Ø) 250 mm x (H) 444 mm; (Ø) 9.84" x (H) 17.48"
Weight	Dome camera — 6.66 kg; 14.68 lbs With wall mount — 7.77 kg; 17.13 lbs With NPT mount — 7.13 kg; 15.72 lbs
Windows	Glass
Body	Aluminum
Housing	Pendant mount

Finish	Powder coat, RAL 9003
Tilt	-20° to 90°, 300° / second max.
Pan	360°, endless, 300° / second max.
Electrical	
Power Consumption	75 W max 105 VA with 24 V AC power
Power Source	V DC: 24 V +/- 10% V AC: 24 Vrms +/- 10%, 50 or 60Hz PoE: 95 W PoE (POE-INJ2-95W)
Power Connector	Wire leads
RTC Backup Battery	3V manganese lithium
Environmental	
Operating Temperature	-40°C to +60°C (-40 °F to 140 °F) with external power or 95 W PoE
Storage Temperature	-10 °C to +70 °C (14 °F to 158 °F)
Humidity	0-95% non-condensing
Certifications	
Certifications	UL, cUL, CE, ROHS, WEEE, RCM
Safety	UL 62368-1, CSA 62368-1, IEC/EN 62368-1
Environmental	IK10 Impact Rating (camera body only) IEC 60529 IP66 Weather Rating IEC/UL/CSA 60950-22
Electromagnetic Emissions	FCC Part 15 Subpart B Class B IC ICES-003 Class B EN 55032 Class B EN 61000-6-3 EN 61000-3-2 EN 61000-3-3
Electromagnetic Immunity	EN 55024 EN 61000-6-1

Limited Warranty and Technical Support

Avigilon warranty terms for this product are provided at [avigilon.com/warranty](https://www.avigilon.com/warranty).

Warranty service and technical support can be obtained by contacting Avigilon Technical Support: [avigilon.com/contact](https://www.avigilon.com/contact).