



Heater/Proofer Cabinets

Models: 177HEAT1836, 177HEAT1836I,
177HPI1812, 177HPI1836,
177HPU1812, 177HPU1836









01/2021

Please read and keep these instructions. Indoor use only.

Index

- Identifying Your Cabinet2
- General Information3
- Product Specifications3
- Installation4
- Care & Maintenance4
- Operating Instructions.....5
- Service Specifications6
- Recommended Temperature Guidelines-Food Holding Chart.....7
- Drawer Assembly8-10
- Cabinet Assembly 11-17
- Electric Schematic Power Supply 18-19
- Troubleshooting20
- Limited Replacement Warranty 21



SAFETY INFORMATION:

-  **WARNING:** Follow all food safety guidelines. Pre-heat the cabinet to the desired temperature before placing cooked, hot food into the cabinet. This is not a re-thermalizing cabinet. Food must be at the appropriate temperature before being placed into this cabinet. Use a food probe to check internal food temperature — the cabinet temperature is not necessarily the internal food temperature.
-  **WARNING:** Only factory-approved service agents should attempt to service, repair or replace electrical components, wiring or power cord.
-  **WARNING:** Unplug the cabinet before cleaning or servicing. Do not wash the cabinet with a water jet or high pressure water.
-  **WARNING:** This cabinet is for hot food holding applications only.
-  **CAUTION:** Do not spray or pour water into the module. To clean the cabinet, wipe with a damp cloth and dry with a towel. Use only cleaning agents approved for aluminum.
-  **CAUTION:** Water dripping onto the floor from open doors can be a slip hazard.

Identifying Your Cabinet

For future reference, cord the cabinet model number and serial number found on the serial plate located on the rear of the cabinet.

MODEL: _____ SERIAL#: _____
 ITEM #: _____ QUANTITY: _____

	MADE IN CHINA 
ITEM: 177HEAT1836I MANUFACTURER ITEM: DESCRIPTION : INSULATED FULL SIZE HEATING & HOLDING MOBILE CABINET WITH CLEAR DOOR VOLTAGE: 120V WATTS: 1440W SERIAL #:	

General Information

The models:

177(1)(2)(3)(4)(5) HEATED CABINETS Series,

- (1) - HEAT "HEAT" (Only Heat) or "H" (Commonly Used)
- (2) - PROOF "P"
- (3) - INSULATE "I"(With Insulate) or "U" (No Insulate)
- (4) - PAN WIDTH INCH
For example 18"
- (5) - PAN QTY - From: 12 to 36
For example: 36

For example: 177 HEAT 18 36
 HEATED CABINETS ONLY HEAT NO PROOF

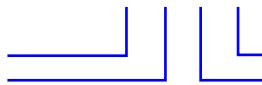
 PAN QTY 36 PCS
 PAN WIDTH 18"
 NO INSULATION

For example: 177 HEAT 18 36 I
 HEATED CABINETS ONLY HEAT NO PROOF

 INSULATED
 PAN QTY 36 PCS
 PAN WIDTH 18"

For example: 177 H P I 18 12
 HEATED CABINETS HEAT PROOF

 PAN QTY 12 PCS
 PAN WIDTH 18"
 INSULATED

For example: 177 H P I 18 36
 HEATED CABINETS HEAT PROOF

 PAN QTY 36 PCS
 PAN WIDTH 18"
 INSULATED

For example: 177 H P U 18 12
 HEATED CABINETS HEAT PROOF

 PAN QTY 12 PCS
 PAN WIDTH 18"
 NO INSULATION

For example: 177 H P U 18 36
 HEATED CABINETS HEAT PROOF

 PAN QTY 36 PCS
 PAN WIDTH 18"
 NO INSULATION

These cabinets are designed to hold hot food at a constant temperature and/or supply humidity when proofing when the application applies. These cabinets are not cooking appliances, and should not be used as such. Safe holding temperatures and regular temperature checks are necessary for safe and sanitation food handling.

Product Specifications

Item #	Function	Cabinet Size	Insulation	Voltage	Wattage	Overall Dimensions (W x D x H)
177HPU1812	Holding/Proofing	Half Size	Non-Insulated	120V	1440W	23.1" x 33.2" x 30.6"
177HPI1812	Holding/Proofing	Half Size	Insulated	120V	1440W	23.1" x 33.4" x 31.6"
177HEAT1836	Heating Only	Full Size	Non-Insulated	120V	1440W	23.1" x 33.2" x 66.5"
177HEAT1836I	Heating only	Full Size	Insulated	120V	1440W	23.1" x 33.4" x 67.5"
177HPU1836	Holding/Proofing	Full Size	Non-Insulated	120V	1440W	23.1" x 33.2" x 66.5"
177HPI1836	Holding/Proofing	Full Size	Insulated	120V	1440W	23.1" x 33.4" x 67.5"

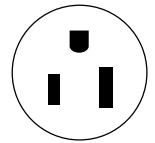

Installation

1. Upon delivery of the unit, check for shipping damage. Check the packaging and cabinet for shipping damage after unloading the unit, and after removing all packaging. Notify freight company immediately of shipping damage with pictures and description.
2. After unpacking the cabinet, set on a stable ground and put casters in the lock position where applicable.
3. Remove all tape and packing material from the outside and inside of the unit.
4. Remove any protective covers on the door and corners of the unit.
NOTE: Use of scrapers (plastic/metal or other material) to remove the protective film on the door may cause scratches and impair see-through visibility.
5. After all packaging is removed, plug the cabinet into a dedicated grounded 120V 15 or 20 Amp outlet.
6. Turn the unit on by using the power switch, flip the unit to "heat" mode and adjust dial to maximum setting 9.
7. Allow the unit to run for at least 1 hour to burn-in the elements and remove any odors evident from the manufacturing process.



NEMA 5-15P

Care & Maintenance

-  **WARNING:** Unplug the cabinet before cleaning or servicing. Do not wash the cabinet with high-pressured water or a water jet.
-  **WARNING:** Allow the unit to completely cool before cleaning. Not allowing the unit to cool causes risk of burn injury from the cabinet surfaces.
-  **CAUTION:** Do not spray or pour water into the heated control drawer module. Excess water may cause the heated control drawer module to short-circuit or cease working.

CLEANING THE CABINET INTERIOR & EXTERIOR (EXCLUDING DOOR PANEL)

1. Ensure the power cord is not plugged in and the cord is off the ground.
2. Open the door and remove the water pan.
3. Remove the heated control drawer module by lifting the front up enough to clear the detent, then pull the module away from the cabinet with the power cord through the rear clearance hole.
4. Using a mild detergent diluted to the manufacturer's specification and a clean cloth, wipe down all interior and exterior surfaces excluding the polycarbonate door panel.
5. Using a clean cloth, wipe down all surfaces and then let air-dry.
6. After air-drying, replace the heated control drawer module by slipping the power cord through the rear clearance hole and sliding the drawer module into the bottom of the unit until it sits on its detent.

DOOR PANEL

1. Ensure the power cord is not plugged in and the cord is off the ground.
2. Using a cleaner recommended for polycarbonate plastics and a clean cloth, wipe down both sides of the door panel.
NOTE: Use of synthetic cloths or cleaners not intended for polycarbonate plastics may scratch or dull the door panel
3. Isopropyl Rubbing Alcohol or a small amount of liquid dish detergent diluted with water may help remove tough grease smudges, dirt, or fingerprints as well as help make the panel antistatic and less likely to attract dust.
4. Paste-wax recommended for polycarbonate plastics and approved for food service equipment can be used to help hide small scratches and return luster and clarity to the door panel as well as help make the panel antistatic and less likely to attract dust.

PREFERRED
CLEANER

**NOBLE**
CHEMICAL INC.

STRIKE
Cleaner/Degreaser

Attack tough grease, oil, and carbon with this ready to use cleaner and degreaser.

Operating Instructions

1. Refer to the Serial Plate for electrical requirements. These cabinets are rated at 120V 1440W and must be plugged into a dedicated grounded 120V 15 or 20 Amp outlet.
NOTE: modification of cord and plug will void warranty and may cause the unit to be inoperable.
2. Ensure the power switch is OFF and plug into appropriate outlet.
3. Fill the water pan to 1/2 from the top with clean HOT tap water for Proofing or if moisture is desired for Holding.
NOTE: Check water level every 3 hours (3 hours when Proofing) and refill with clean HOT tap water as necessary.
NOTE: water pan does not have to be used/filled for heating applications that do not require moisture.
NOTE: Proofing mode requires use of water pan to be filled.

CONTROL PANELS

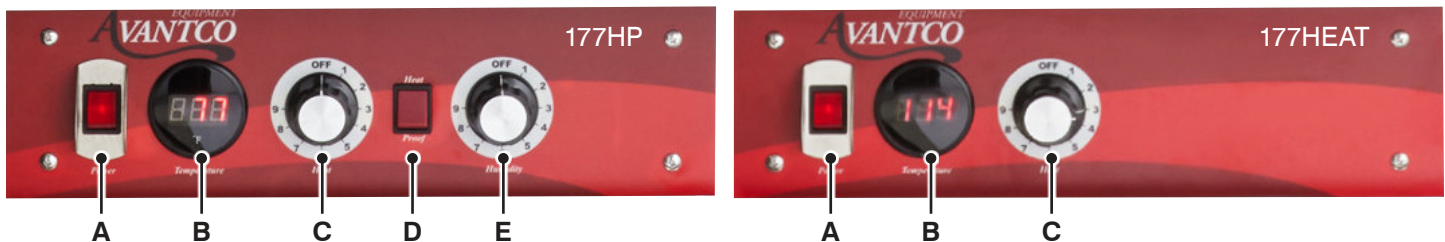

HEATING/HOLDING INSTRUCTIONS

1. Set HEAT/PROOF Switch (D) to **HEAT**.
2. Set POWER switch (A) to the **ON** position. Power indicator light will turn on.
3. Set TEMPERATURE control (C) to **9**.
4. Pre-heat cabinet until desired temperature is reached (typical heat-up time from 77°F (25°C) ambient to 160°F (71°C) is approximately 45 minutes). Cabinet temperature reaches 185°F (85°C) within approximately 45 minutes.
5. Re-set TEMPERATURE control (C) and adjust as necessary to reach desired temperature (setting 6-8 is typical for 150°F (66°C) to 160°F (71°C)).
6. Adjust HUMIDITY control (E) to desired level. (9 being the highest, 1 the lowest, OFF being no heat to the water)

PROOFING INSTRUCTIONS

1. Set HEAT/PROOF Switch (D) to **PROOF**.
2. Set POWER switch (A) to the **ON** position. Power indicator light will turn on.
3. Set TEMPERATURE control (C) to **2**.
4. Set HUMIDITY control (E) to **9**.
5. Pre-heat cabinet until desired temperature and humidity is reached (typical heat-up time from 77°F (25°C) ambient to 95°F (35°C) and 95% relative humidity is approximately 30 minutes).
6. Adjust HUMIDITY control (E) to desired level. (9 being the highest, 1 the lowest, OFF being no heat to the water)

NOTE: Settings will need to be adjusted as necessary to reach desired temperature and humidity levels.

NOTE: The internal air circulation blower and 1440W heating element (controlled with the Heat Thermostat) will operate continuously when the power switch is turned ON.

HEATING/HOLDING INSTRUCTIONS

The temperature range for heating/holding control is 80-185°F. The dial numbers 1-9 do not correspond or relate to a specific calibrated temperature. Exact temperature settings must be obtained through familiarization with the unit and are dependent on the ambient environment temperature and conditions where the unit is placed. The dial also has an OFF position to turn the heater off. Hot holding of food must be done to proper safe food handling and storage practices. This unit is not a cooker and not meant to cook or rethermalize food.

HUMIDITY/PROOFING CONTROL

The humidity range for humidity/proofing control is 30-100%. The dial numbers 1-9 do not correspond or relate to a specific calibrated humidity %. Exact humidity settings must be obtained through familiarization with the unit and are dependent on the ambient environment temperature and conditions where the unit is placed. The dial also has an OFF position to turn the humidity off. To maintain low temperature range between 85-100°F, switch the proof mode and adjust the heat/holding control knob to desired heat range. Allow the unit 45 minutes to pre-heat in proofing mode. NOTE: A use of a hygrometer is recommended for precision proofing applications. For proofing, trial batches and altering control settings is recommended to dial in the unit to the users exact requirements based on the ambient temperature and conditions.

Service Specifications

The Heater-Proofing is an aluminum transport cabinet with heaters to function as a hot food holding cabinet and/or as a proofing cabinet.

The heater, or heat drawer, is slid into place on the lower ledges of the cabinet. An electrical power cord is provided and plugged into the drawer through an access hole in the back of the cabinet. The main power switch on the front of the drawer, when switched ON, will turn on the light in the switch and turn on the air circulating fan in the drawer. The circulating fan and 1440W heater element will operate continuously while the unit is ON.

The thermostat control knobs are mounted to the left and right of the HEAT/PROOF switch. The left thermostat knob controls the heat in the cabinet from 1 (approx. 30% relative humidity) to 9 (100% relative humidity). Average setting is 6 (approx. 85% relative humidity).

Recommended Temperature Guidelines Food Holding Chart

Food Product	Covered/Uncovered	Temperature Setting
Baked Fish	Uncovered	175°F
Baked Potatoes	Uncovered	180°F
Biscuit	Covered	180°F
Broccoli	Uncovered	170-175°F
Chicken Nuggets	Covered	175°F
Corn on the Cob	Uncovered	170-175°F
Croissants	Covered	175°F
Egg Patties	Uncovered	180°F
French Fries	Uncovered	185°F
Fried Chicken	Uncovered	180-185°F
Fried Fish	Uncovered	180°F
Hamburgers	Covered	180°F
Lasagna	Covered	185°F
Mashed Potatoes	Covered	175°F
Mixed Veggies	Covered	170-175°F
Pancakes	Covered	175°F
Pastas	Covered	180°F
Peas	Covered	170-175°F
Pizza	Uncovered	175-180°F
Roast Beef	Uncovered	170-180°F
Roast Pork	Uncovered	170-180°F
Scalloped Potatoes	Covered	175°F
Strip Steak	Uncovered	160-170°F
Turkey	Uncovered	170-180°F
Waffles	Covered	175°F
Whole Chicken	Uncovered	170-180°F

Drawer Assembly

177DRWRHP Drawer Diagram

For Models 177HPU1812, 177HPI1812, 177HPU1836 & 177HPI1836

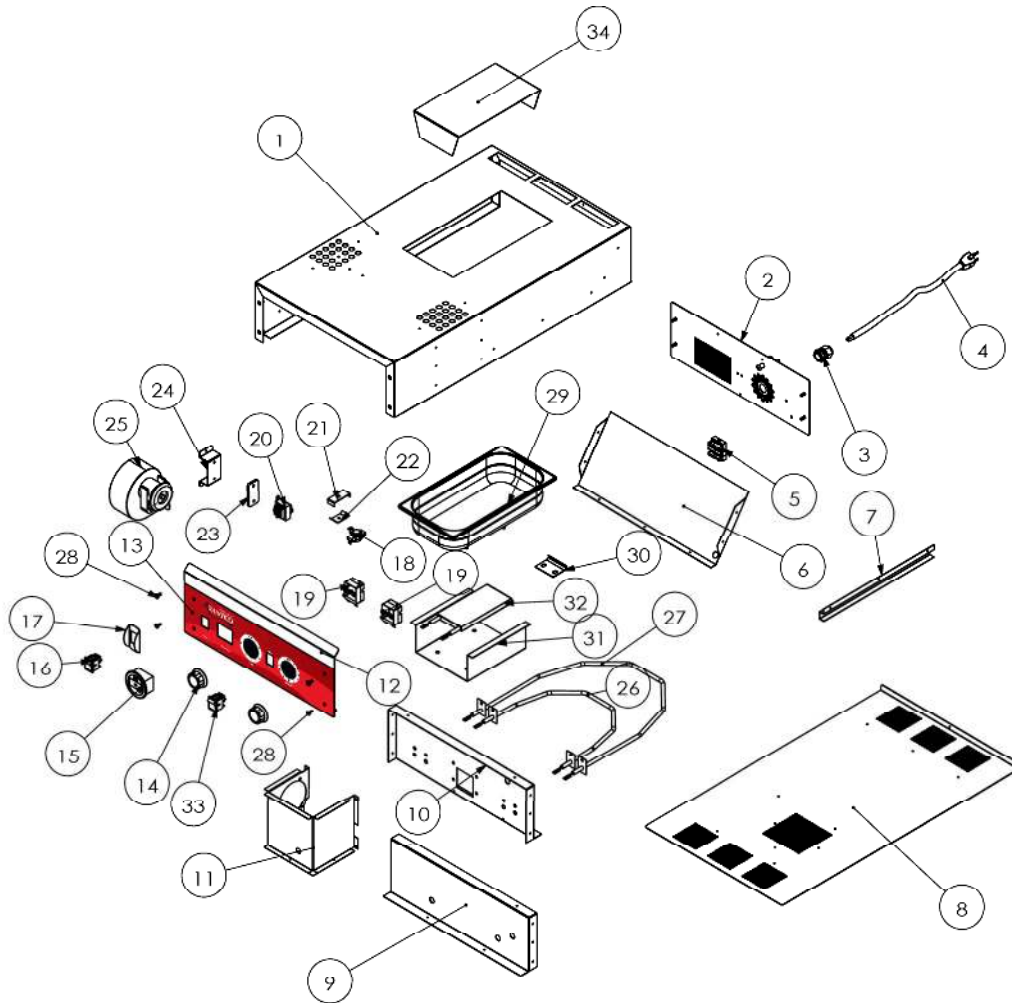

Drawer Assembly

177DRWRHEAT Drawer Diagram

For Models 177HEAT1836 & 177HEAT1836I

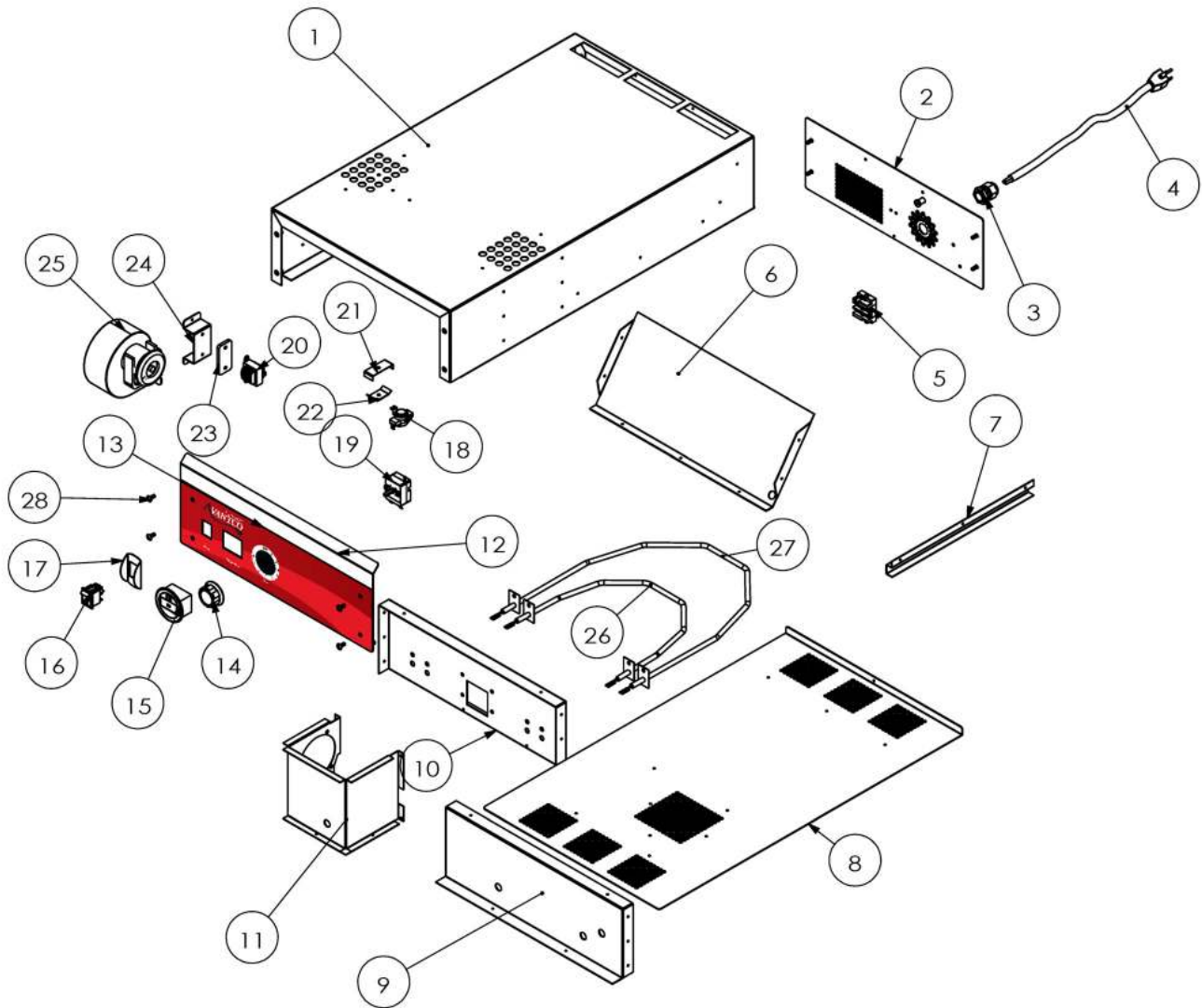

Drawer Replacement Parts

Item #	Diagram #	Photo	Part No.	Description	177DRWRHP Quantity	177DRWRHP Quantity
-	03		HCD-030	Cable Bushing	1	1
177PCORD	04		HCD-031	Power Cable	1	1
-	05		HCD-026	Terminal Block	1	1
177PHCD035	14		HCD-035	Knob	2	1
-	15		HCD-024	Thermometer	1	1
-	16		HCD-016	Main Switch with Red Light	1	1
177PHCD019	18		HCD-019	Limit Temperature Thermostat	1	1
177PHCD034	19		HCD-034	Temperature Thermostat	2	1
-	20		HCD-017	Transformer	1	1
177PHCD011	27		HCD-011	Heating Element 900W	1	1
177PHCD010	26		HCD-010	Heating Element 600W	1	1
-	29		HCD-008	SS Water Pan	1	N/A
177PHCD009	32		HCD-009	Heating Element 600W	1	N/A
177PHCD036	36		HCD-036	Heat/Proof Switch with Red Light	1	N/A

Cabinet Assembly

177HPI1836 Diagram

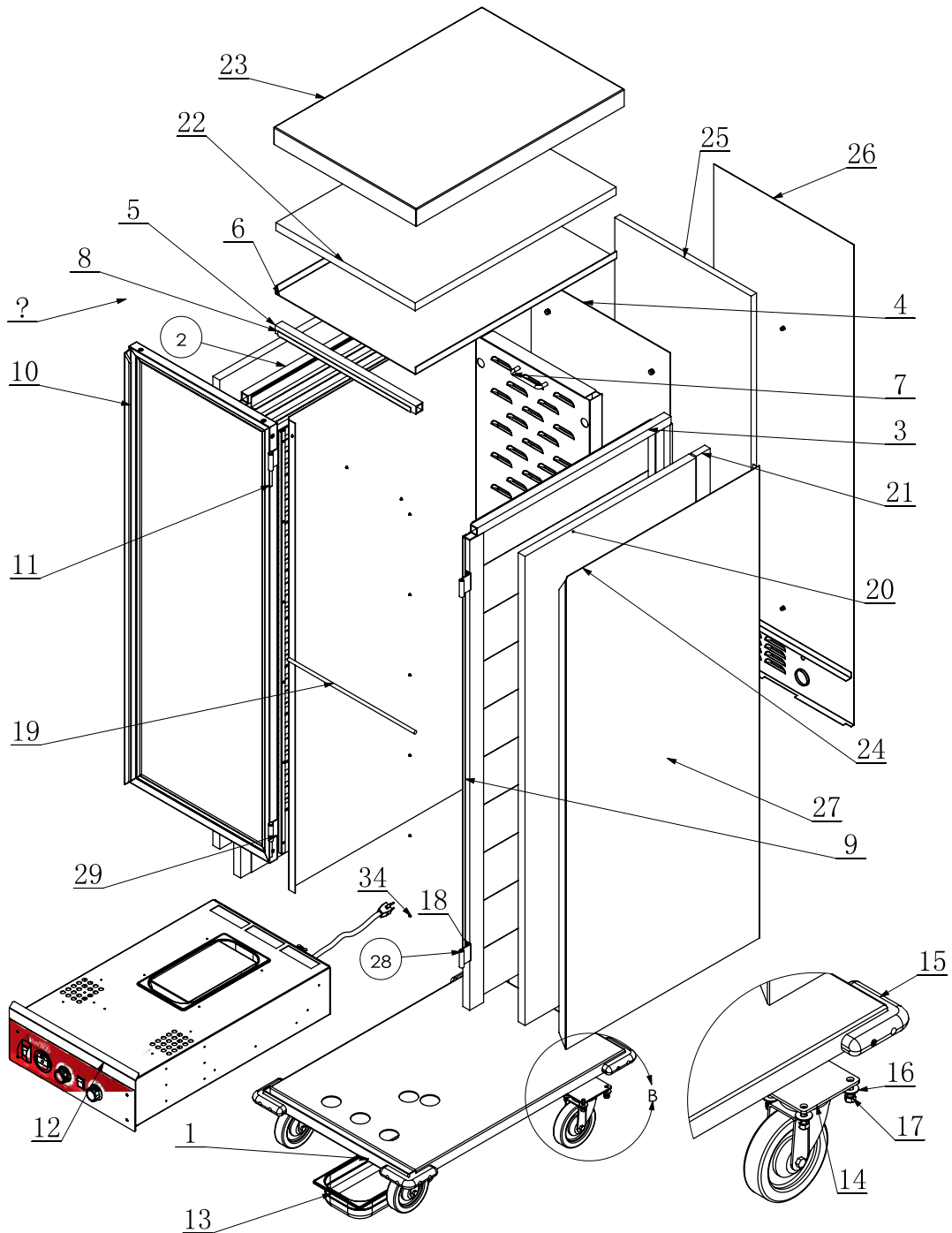

Cabinet Assembly

177HPU1836 Diagram

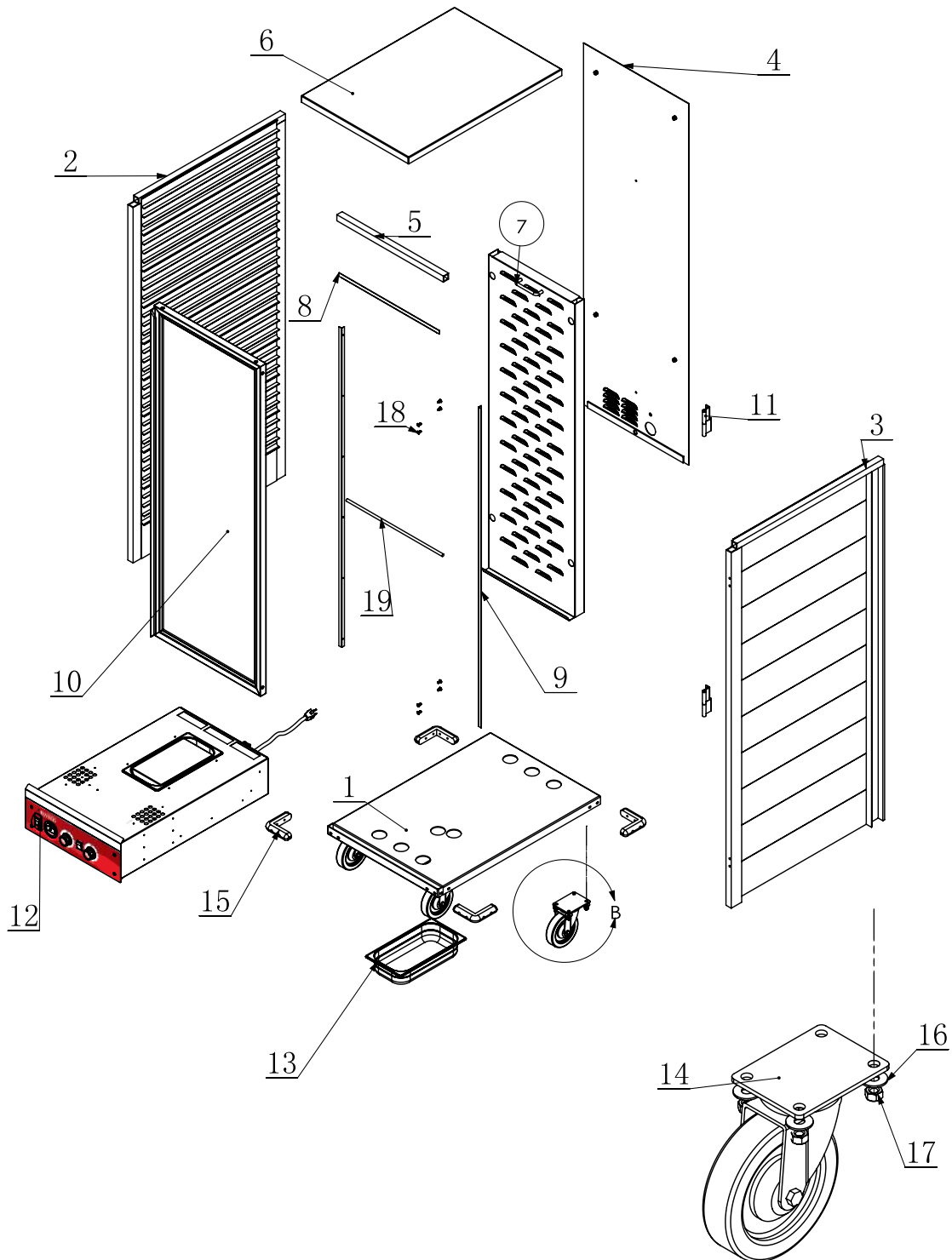

Cabinet Assembly

177HEAT1836 Diagram

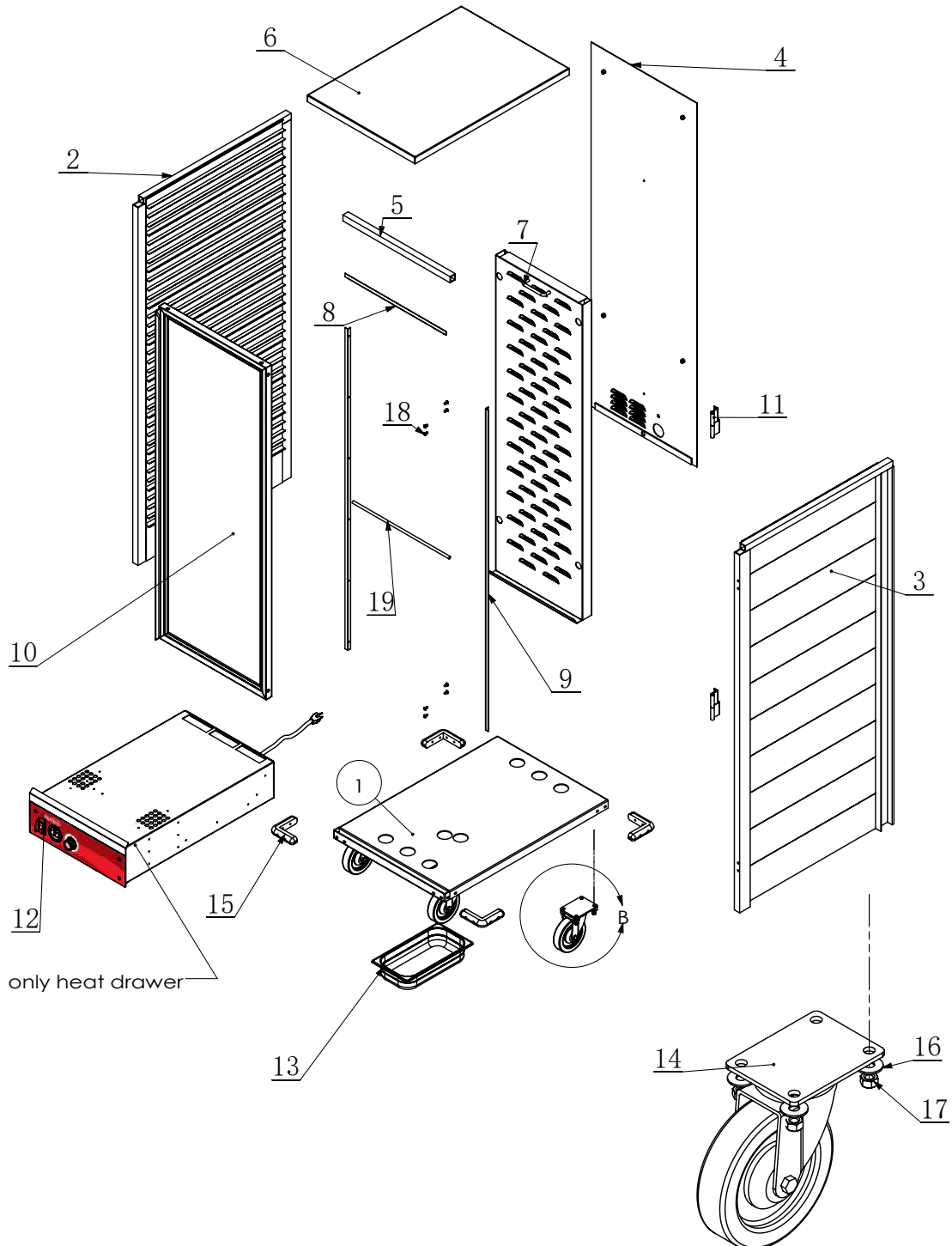

Cabinet Assembly

177HEAT1836I Diagram

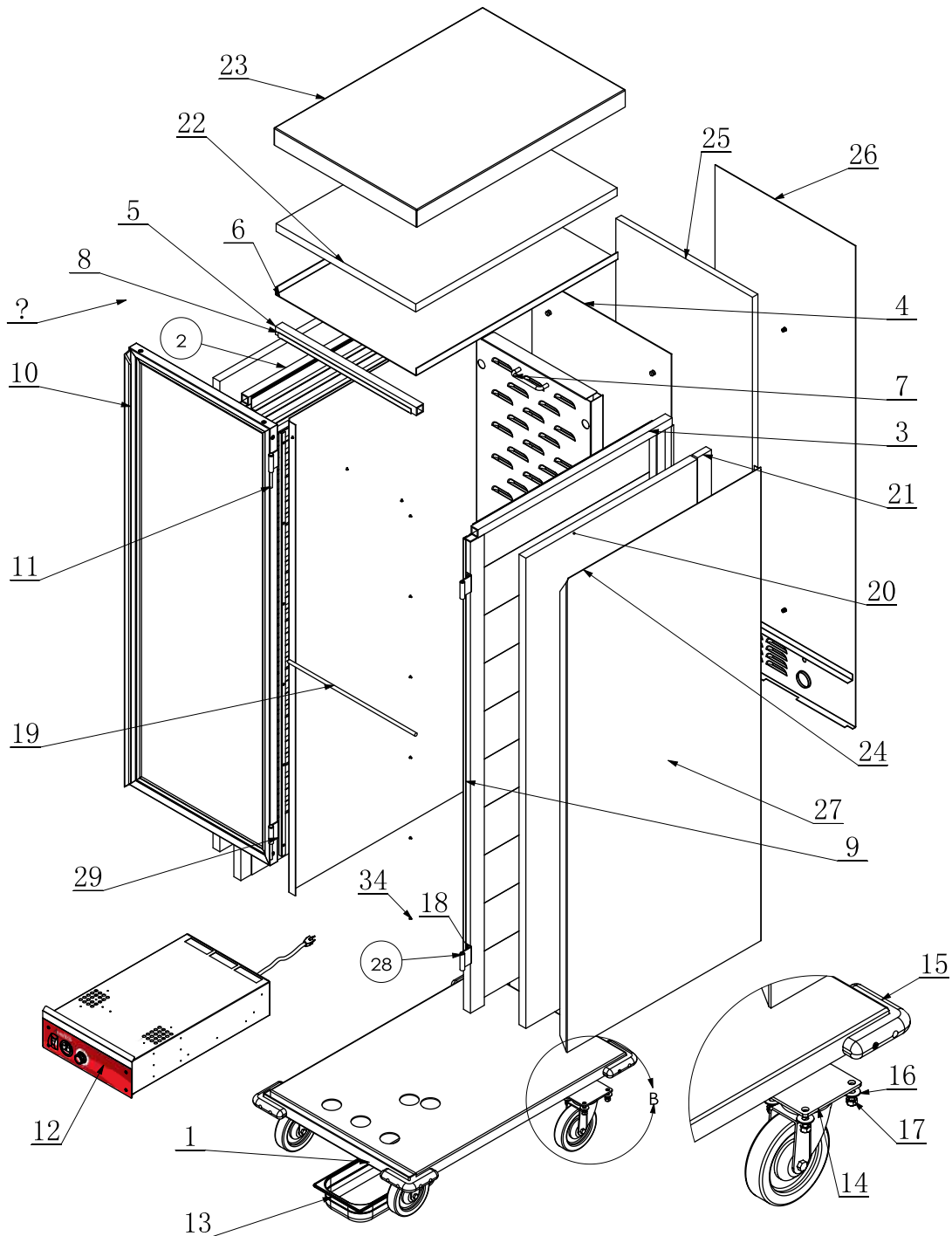

Cabinet Assembly

177HPU1812 Diagram

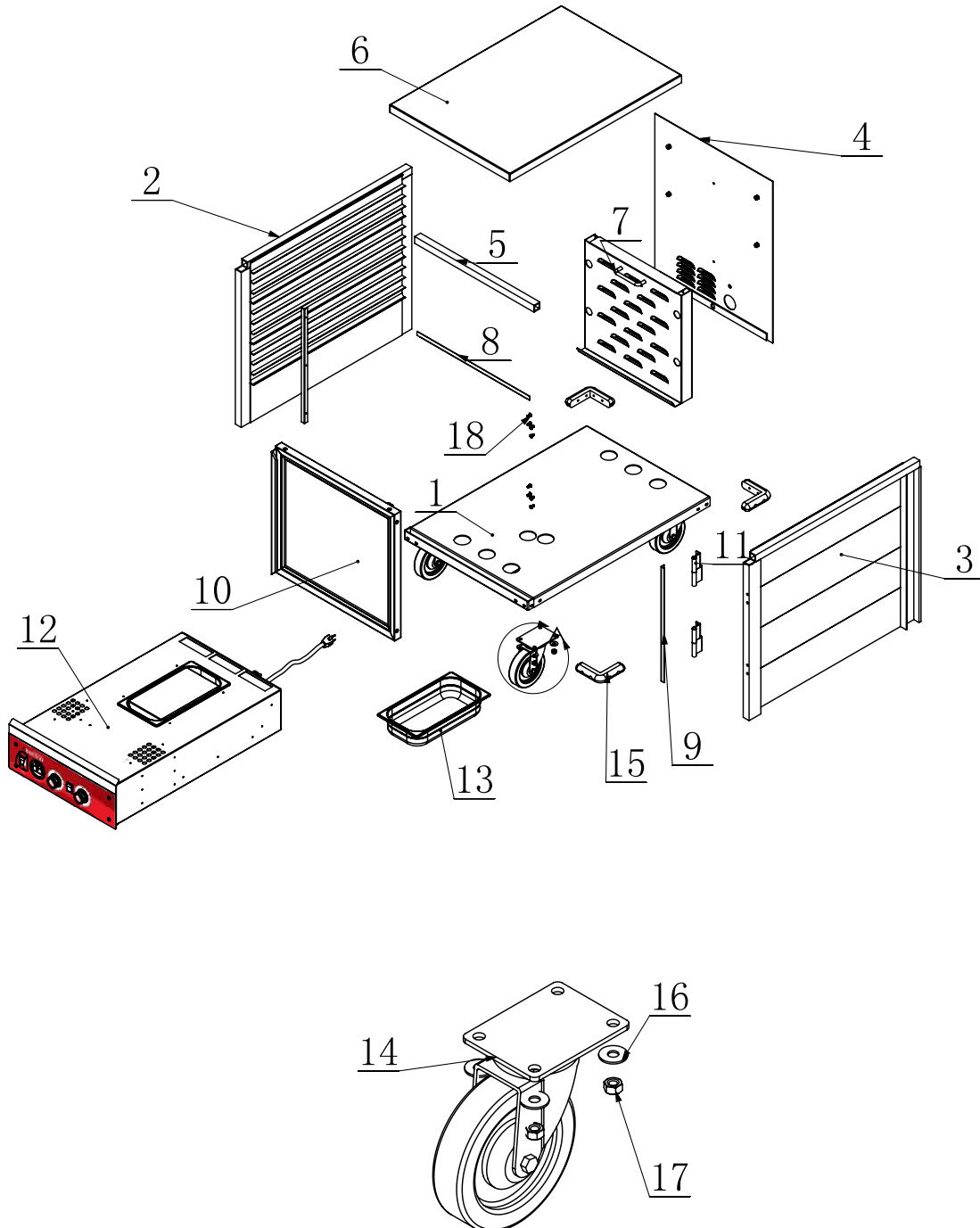

Cabinet Assembly

177HPI1812 Diagram

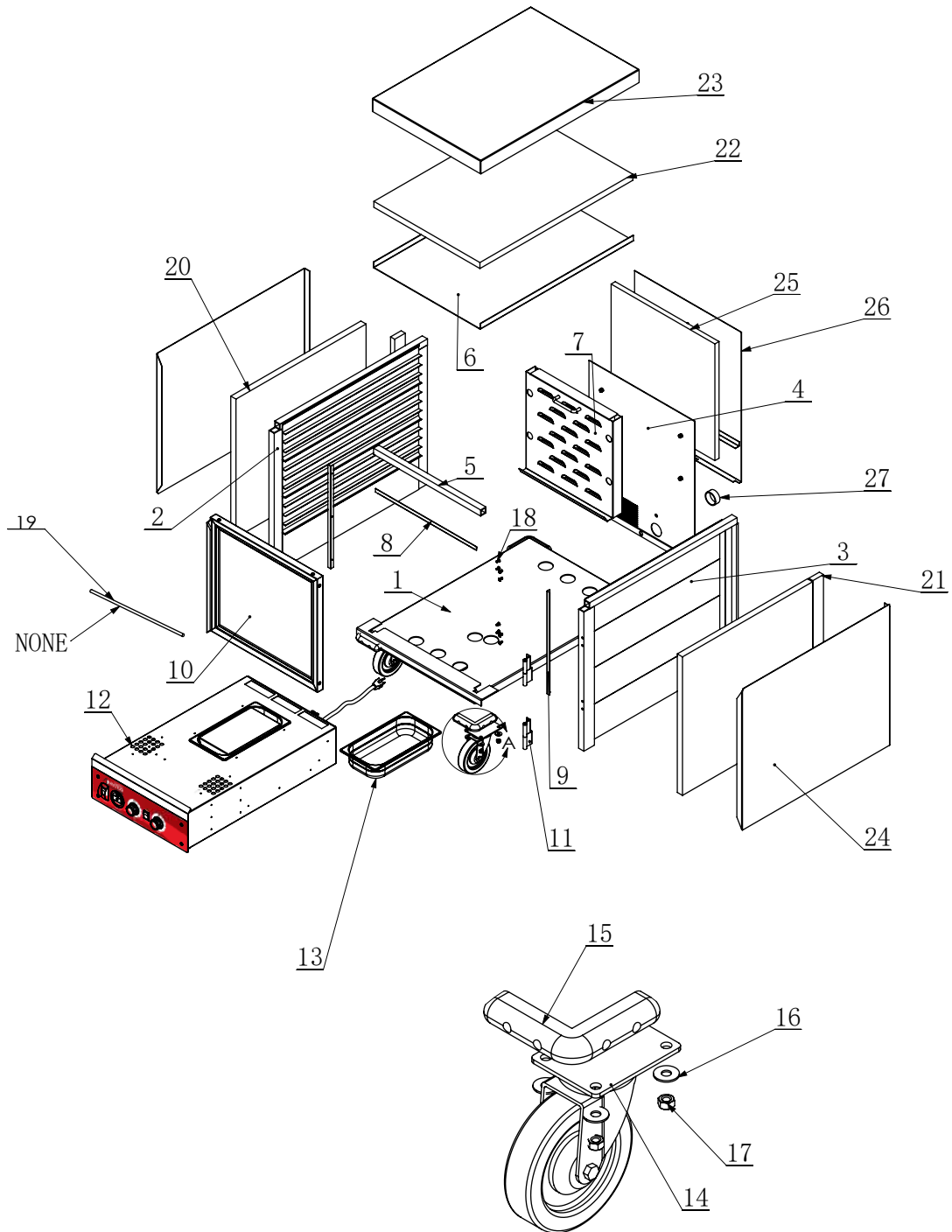

Cabinet Replacement Parts

Item #	Description	Quantity	Use for Cabinets
07	Half Size Rear Hanging Panel	1	177HPU1812 177HPI1812
07	Full Size Rear Hanging Panel	1	177HPU1836 177HPI1836 177HEAT1836 177HEAT1836I
08/09	Magnetic Strips (Top 1 pc., Left/Right 2 pcs. Included)	1	177HPU1812 177HPI1812
08/09	Magnetic Strips (Top 1 pc., Left/Right 2 pcs. Included)	1	177HPU1836 177HPI1836 177HEAT1836 177HEAT1836I
10	Half Size Door Assembly	1	177HPU1812 177HPI1812
10	Full Size Door Assembly	1	177HPU1836 177HPI1836 177HEAT1836 177HEAT1836I
11	Hinge	2	All Models
12	Combination Holding/Proofing Drawer	1	177HPU1812 177HPI1812 177HPU1836 177HPI1836
12	Heating Drawer	1	177HEAT1836 177HEAT1836I
13	Black Plastic Drip Pan	1	All Models
14	5" Caster with Brake (Hardware Included)	4	All Models
15	Rubber Corner Bumper	4	All Models

Electric Schematic Power Supply

HEAT/PROOF Models (177HP Drawer)

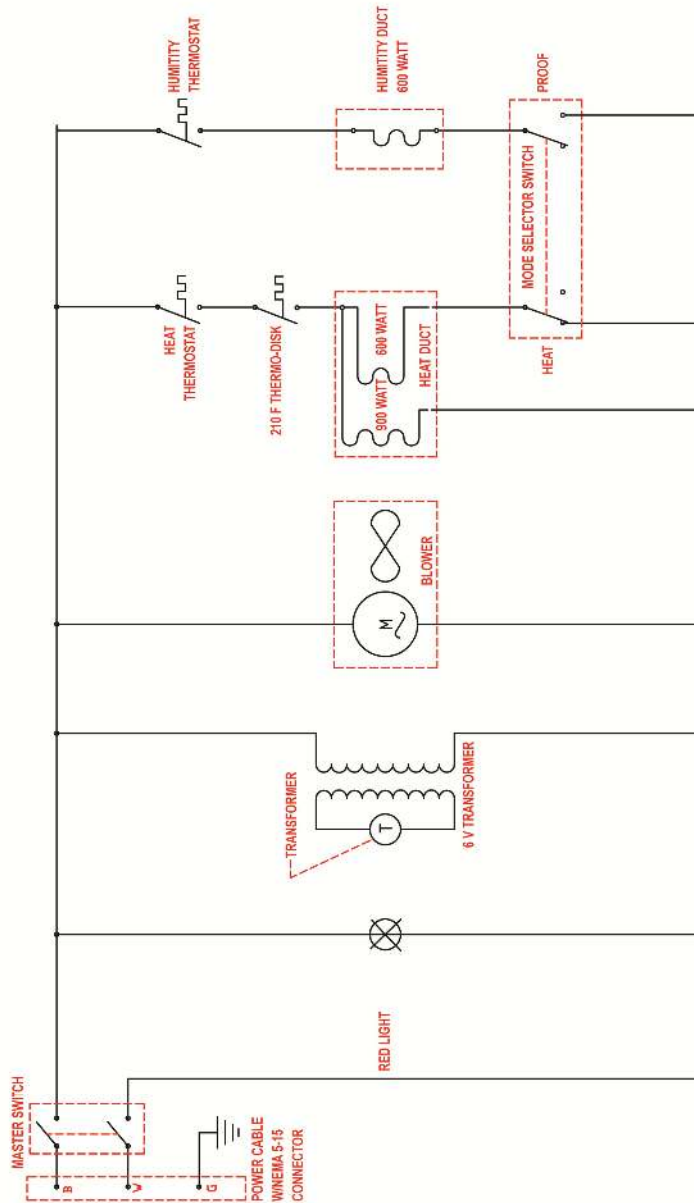

Only HEAT Models (177HEAT Drawer)

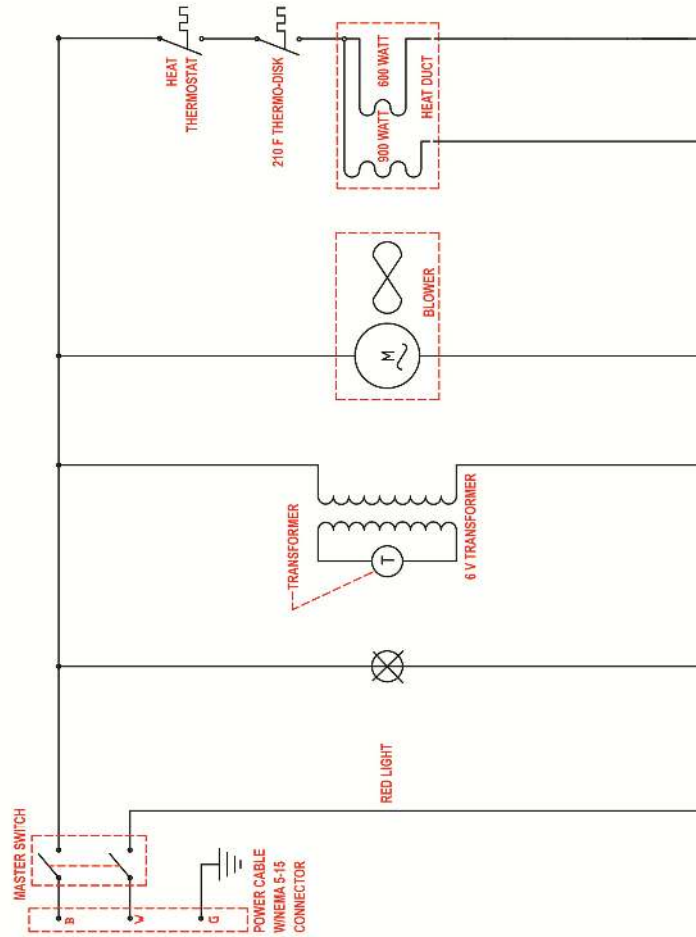

Troubleshooting

CAUTION

Before disassembling unit, electrical power must be disconnected by unplugging the unit. Failure to unplug the unit prior to servicing may result in electrical shock.

Each unit is shipped with this instruction manual and should be used as a reference guide for all service areas. The manual provides a picture of the drawer, showing the location of electrical components and a description of each. If the unit does not operate correctly, or malfunctions for any reason, the following check list should provide a solution.

- 1) Check to make sure power cord is firmly plugged into the wall outlet.
- 2) Check circuit breaker of wall outlet and reset if necessary.

IF unit fails to start, please do the following:

- 3) Remove heat drawer from cabinet. Remove bottom cover of drawer. Visually inspect to observe for:
 - a. Loose or disconnected wires
 - b. Black or burnt marks on any components
 - c. Loose heating elements
- 4) If any burn marks or discoloration of wires is noted on any component, the component along with all wires attached to the damaged component must be replaced.
- 5) If a heater element is loose, or if it has broken loose from mounting tabs, the wires will short out on the metal, causing permanent damage. Both the element and main power switch (with wires on switch) must be replaced.
- 6) If the temperature on the LED Thermometer is not reading a constant temperature, it must be replaced along with its power supply transformer.

Equipment Limited Warranty

Avantco warrants its equipment to be free from defects in material and workmanship for a period of 1 year. This is the sole and exclusive warranty made by Avantco covering your Avantco brand equipment. A claim under this warranty must be made within **1 year** from the **date of purchase** of the equipment. Only the equipment's original purchaser may make a claim under this warranty. Avantco reserves the right to approve or deny the repair or replacement of any part or repair request. The warranty is not transferable. Avantco Equipment installed in/on a food truck or trailer will be limited to a period of **30 days** from the original date of purchase.

To Make a Warranty Claim:

For Warranty Inquiries contact the location where you purchased the product:

- **WebstaurantStore.com:** Contact help@webstaurantstore.com. Please have your order number ready.
- **The Restaurant Store:** If you purchased this unit from your local store, please contact your store directly.
- **TheRestaurantStore.com:** Online purchases, call 717-392-7261. Please have your order number ready.

Failure to contact the designated location prior to obtaining equipment service may void your warranty.

Avantco makes no other warranties, express or implied, statutory or otherwise, and **HEREBY DISCLAIMS ALL IMPLIED WARRANTIES, INCLUDING THE IMPLIED WARRANTIES OF MERCHANTABILITY AND OF FITNESS FOR A PARTICULAR PURPOSE.**

This Limited Warranty does not cover:

- Equipment sold or used outside the Continental United States
- Use of unfiltered water (if applicable)
- Avantco has the sole discretion on wearable parts not covered under warranty
- Equipment not purchased directly from an authorized dealer
- Equipment used for residential or other non-commercial purposes
- Equipment that has been altered, modified, or repaired by anyone other than an authorized service agency
- Equipment where the serial number plate has been removed or altered.
- Damage or failure due to improper installation, improper utility connection or supply, and issues resulting from improper ventilation or airflow.
- Defects and damage due to improper maintenance, wear and tear, misuse, abuse, vandalism, or Act of God.

Any action for breach of this warranty must be commenced within 1 year of the date on which the breach occurred. No modification of this warranty, or waiver of its terms, shall be effective unless approved in a writing signed by the parties. The laws of the Commonwealth of Pennsylvania shall govern this warranty and the parties' rights and duties under it. Avantco shall not under any circumstances be liable for incidental or consequential damages of any kind, including but not limited to loss of profits.