

# 1-channel U-shaped Photoelectric Sensors

## BUP Series INSTRUCTION MANUAL

TCD210060AD

**Autonics**

Thank you for choosing our Autonics product.

**Read and understand the instruction manual and manual thoroughly before using the product.**

**For your safety, read and follow the below safety considerations before using.**

**For your safety, read and follow the considerations written in the instruction manual, other manuals and Autonics website.**

Keep this instruction manual in a place where you can find easily.

The specifications, dimensions, etc. are subject to change without notice for product improvement. Some models may be discontinued without notice.

Follow Autonics website for the latest information.

### Safety Considerations

- Observe all 'Safety Considerations' for safe and proper operation to avoid hazards.
- ⚠ symbol indicates caution due to special circumstances in which hazards may occur.

**⚠ Warning** Failure to follow instructions may result in serious injury or death.

**01. Fail-safe device must be installed when using the unit with machinery that may cause serious injury or substantial economic loss. (e.g., nuclear power control, medical equipment, ships, vehicles, railways, aircraft, combustion apparatus, safety equipment, crime/disaster prevention devices, etc.)**

Failure to follow this instruction may result in personal injury, economic loss or fire.

**02. Do not use the unit in the place where flammable/explosive/corrosive gas, high humidity, direct sunlight, radiant heat, vibration, impact or salinity may be present.**

Failure to follow this instruction may result in explosion or fire.

**03. Do not disassemble or modify the unit.**

Failure to follow this instruction may result in fire.

**04. Do not connect, repair, or inspect the unit while connected to a power source.**

Failure to follow this instruction may result in fire.

**05. Check 'Connections' before wiring.**

Failure to follow this instruction may result in fire.

**⚠ Caution** Failure to follow instructions may result in injury or product damage.

**01. Use the unit within the rated specifications.**

Failure to follow this instruction may result in fire or product damage.

**02. Use a dry cloth to clean the unit, and do not use water or organic solvent.**

Failure to follow this instruction may result in fire.

### Cautions during Use

- Follow instructions in 'Cautions during Use'. Otherwise, It may cause unexpected accidents.
- When connecting an inductive load such as DC relay or solenoid valve to the output, remove surge by using diodes or varistors.
- Use the product after 0.5 sec of the power input.
- When using a separate power supply for the sensor and load, supply power to the sensor first.
- 12-24 VDC power supply should be insulated and limited voltage/current or Class 2, SELV power supply device.
- Wire as short as possible and keep it away from high voltage lines or power lines to prevent surge and inductive noise.
- When using switching mode power supply (SMPS), ground F.G. terminal and connect a condenser between 0V and F.G. terminal to remove noise.
- When using a sensor with a noise-generating equipment (e.g., switching regulator, inverter, and servo motor), ground F.G. terminal of the equipment.
- This unit may be used in the following environments.
  - Indoors (in the environment condition rated in 'Specifications')
  - Altitude max. 2,000 m
  - Pollution degree 2
  - Installation category III

### Product Components

- Product
- Instruction manual
- Adjustment screwdriver (sensitivity adjustable model)

### Ordering Information

This is only for reference, the actual product does not support all combinations. For selecting the specified model, follow the Autonics website.

**BUP - ① - ② - ③ - ④**

#### ① Sensing distance

Number: Sensing distance (unit: mm)

#### ② Function

No mark: Fixed sensitivity  
S: Sensitivity adjustable

#### ③ Connection

No mark: Cable type  
E: Cable connector type

#### ④ Control output

No mark: NPN open collector output  
P: PNP open collector output

### Cautions during Installation

- Be sure to install this product by following the usage environment, location, and specified ratings. Consider the listed conditions below.
  - Installation environment and background (reflected light)
  - Sensing distance and sensing target
  - Direction of target's movement
- For installation, tighten the M5 screw with a torque of 1.96 N m (sensing distance 30 mm model), M8 screw with a torque of 4.9 N m (sensing distance 50 mm model).
- Do not impact with a hard object or bend the cable excessively. That could decrease the product's water resistance.
- Use this product after the test. Check whether the indicator works appropriately for the positions of the detectable object.

### Operation Timing Chart

Operation mode	Light ON	Dark ON
Received light	Received Interrupted	Received Interrupted
Operation indicator (red)	ON OFF	ON OFF
Transistor output	ON OFF	ON OFF

### Connections

#### ■ Cable type

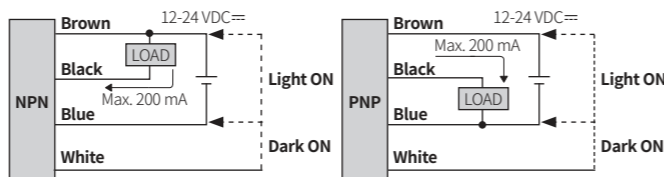

#### ■ Cable connector type

- Connector: Daedong Inc., MIC-5M

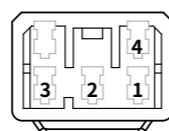

Pin	Color	Function
①	Brown	+V
②	Blue	0V
③	Black	OUT
④	White	Control

#### ■ Operation mode selection

⚠ Be sure to connect the control wire when selecting the operation mode. Failure to this instruction may result in product damage.

Operation mode	Wiring
Light ON	Connect the control wire (white) to +V (brown)
Dark ON	Connect the control wire (white) to 0V (blue)

### Circuit

#### ■ NPN open collector output

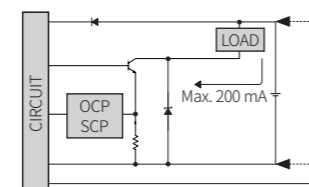

#### ■ PNP open collector output

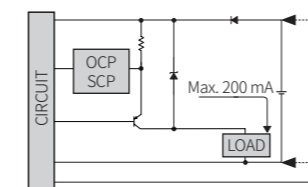

- OCP (over current protection), SCP (short circuit protection)
- If short-circuit the control output terminal or supply current over the rated specification, normal control signal is not output due to the protection circuit.

### Sensitivity Adjustment

- Set the adjuster for stable Light ON area, minimizing the effect of the installation environment.
- Use the offered adjustment screwdriver. Do NOT turn with excessive force to prevent product damage.
- The steps below are based on Light ON mode.

STEP	Status	Description
01	Received	Turn the adjuster from MIN to MAX sensitivity and check the position (A) where the operation indicator activates under the light ON area.
02	Interrupted	Turn the adjuster from (A) to MAX and check the position (B) where the operation indicator activates under the light OFF area. If the operation indicator does NOT activate at the MAX (maximum sensitivity): MAX = (B).
03	-	Set the adjuster at the mid position between (A) and (B) for optimal sensitivity.

### Dimensions

- Unit: mm, For the detailed drawings, follow the Autonics website.
- The sensors have the same size depending on the sensing distance.

A	Optical axis	C	Power indicator (green)
B	Operation indicator (red)	D	Sensitivity adjuster (sensitivity adjustable model)

#### ■ Sensing distance 30 mm model

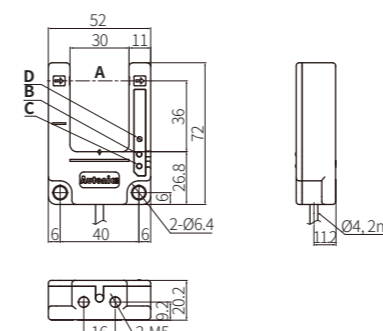

#### ■ Sensing distance 50 mm model

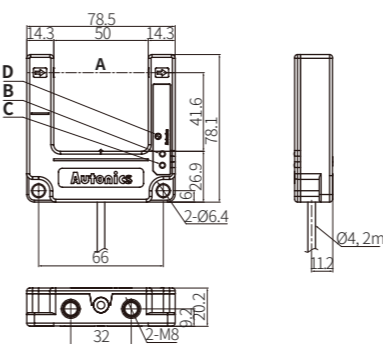

#### ■ Connector

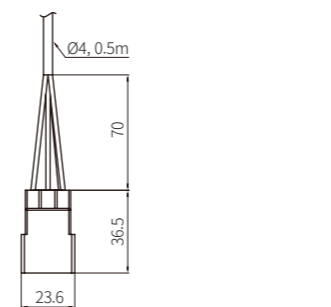

### Specifications

Model	BUP-□-□	BUP-□-E	BUP-□S-□
Sensing type	Through-beam		
Sensing distance	30 mm	50 mm	30 mm 50 mm
Sensing target	Opaque materials		
Min. sensing target	≥ Ø 4 mm		≥ Ø 1.5 mm
Response time	≤ 1 ms		
Light source	Infrared		
Peak emission wavelength	940 nm		
Sensitivity adjustment	Fixed	YES (Adjuster)	
Operation mode	Light ON mode - Dark ON mode selectable (Control wire)		
Indicator	Operation indicator (red), power indicator (green)		
Approval	CE ENEC	CE	CE ENEC
Unit weight (packaged)	≈ 85 g (≈ 120 g)	≈ 115 g (≈ 160 g)	≈ 60 g (≈ 95 g) ≈ 90 g (≈ 125 g) ≈ 85 g (≈ 120 g) ≈ 115 g (≈ 160 g)

Power supply	12-24 VDC ± 10% (ripple P-P: ≤ 10%)
Current consumption	≤ 30 mA
Control output	NPN open collector output / PNP open collector output model
Load voltage	≤ 30 VDC
Load current	≤ 200 mA
Residual voltage	NPN: ≤ 1 VDC, PNP: ≤ 2.5 VDC
Protection circuit	Reverse power protection circuit, output short overcurrent protection circuit
Insulation resistance	≥ 20 MΩ (500 VDC megger)
Noise immunity	± 240 VDC square wave noise (pulse width: 1 μs) by the noise simulator
Dielectric strength	1,000 VAC ~ 50/60 Hz for 1 min
Vibration	1.5 mm double amplitude at frequency of 10 to 55 Hz (for 1 min) in each X, Y, Z direction for 2 hours
Shock	500 m/s² (≈ 50 G) in each X, Y, Z direction for 3 times
Ambient illuminance (receiver)	Sunlight: ≤ 11,000 lx, incandescent lamp: ≤ 3,000 lx
Ambient temperature	Fixed sensitivity model: -25 to 65 °C, storage: -25 to 70 °C (no freezing or condensation) Sensitivity adjustable model: -10 to 60 °C, storage: -25 to 70 °C (no freezing or condensation)
Ambient humidity	35 to 85 %RH, storage: 35 to 85 %RH (no freezing or condensation)
Protection rating	Fixed sensitivity model: IP66 (IEC standard) Sensitivity adjustable model: IP50 (IEC standard)
Connection	Cable type, cable connector type
Cable spec.	Cable type: Ø 4 mm, 4-wire, 2 m Cable connector type: Ø 4 mm, 4-wire, 0.5 m
Wire spec.	AWG22 (0.08 mm, 60-core), insulator outer diameter: Ø 1.25 mm
Connector	5-pin socket type
Material	Case: ABS, CAP: PC