



12-15FT TRAMPOLINE & Enclosure



ASSEMBLY INSTRUCTIONS

Model: AZJ-12FT BASIC & AZJ-15FT BASIC

6+

Not recommended for children under 6 years of age.

CONTACT INFO

Distributed by Airzone Ltd.

Questions or Comments? Call **1-800-775-6524** or Mail **CustomerService@airzone-na.com**

Made in China.

Two or more adults required for assembly



IMPORTANT

After receiving the shipment, inspect the product thoroughly to ensure that it has been shipped with care.

Before assembly make sure that the packaging contains all parts.

For service or parts replacement under warranty, the official sales receipt and serial number sticker is required. Please keep your official sales receipt for future reference

OFFICIAL SALES RECEIPT CAN BE ATTACHED HERE

Service or parts under warranty
only available with show of Receipt,
Sticker with Serial Number and Instruction Manual

SERIAL NUMBER

DO NOT return this product to the place of purchase.

Please contact us for any questions or comments at **1-800-775-6524** or
Mail **CustomerService@airzone-na.com**

Save these IMPORTANT Safety Instructions

WARNING

Read these materials prior to assembling and using this trampoline and enclosure. Keep this manual so you can refer to it later.

Age Grade 6+: Trampolines over 20 inch (51cm) tall are not recommended for children under 6 years of age.



It is strongly recommended that the customer purchase, install and maintain an enclosure that complies with safety Specification F2225. This enclosure is to be used only in connection with certain trampolines.

For recreational use ONLY. Not for professional use.
User weight limit for 12ft and larger trampolines and enclosures is 200 lbs.

TABLE OF CONTENTS

WARNING

- 03 - Liability
- 03-04 - Initial Warning
- 04-05 - Assembly and Installation Instructions
- 05 - Care and Maintenance Instructions
- 06-08 - User instructions
- 08 - Owner's and Supervisor's Role in Preventing Injuries & Responsibilities
- 08 - User's Role in Preventing Injuries and Responsibilities
- 09 - Trampolines Safety and Accident Prevention
- 10-12 - Fundamental Bounces
- 13-17 - Trampoline and Enclosure Assembly
- 18-19 - Limited Warranty

LIABILITY

While every attempt is made to embody the highest degree of protection in all equipment, we cannot guarantee freedom from injury. The user assumes all risks of injury due to use of this product. All merchandise is sold on this condition, which no representative of the company can waive or change.

WARNING

In addition to the instructions and precautions provided with your trampoline and enclosure, the following precautions must be observed:

DO NOT attempt or allow somersaults on the trampoline. Landing on the head or neck can cause serious injury, paralysis, or death, even when landing in the middle of the bed. (7.4.2.1)

Do not allow more than one person inside the trampoline enclosure. Use by more than one person at the same time can result in serious injury. (7.4.2.2)

Use trampoline and enclosure only with mature, knowledgeable supervision. (7.4.2.3)

Adequate overhead clearance is essential. A minimum of 24ft from ground level is recommended. Provide clearance for wires, tree limbs and other possible hazards. (7.2.3.1)

Lateral clearance is essential. Place the trampoline and enclosure away from walls, structures, fences and other play areas. Maintain a clear space on all sides of the trampolines and enclosure. (7.2.3.2)

Place the trampoline and enclosure on a level surface before use. (7.2.3.3)

WARNING CONTINUED

Use the trampoline and enclosure in a well-lighted area. Artificial illumination may be required for indoor or shady areas. (7.2.3.4)

Secure the trampoline and enclosure against unauthorized and unsupervised use. (7.2.3.5)

Remove any obstructions from beneath the trampoline and enclosure. (7.2.3.6)

The trampoline enclosure is only to be used as an enclosure for a trampoline of a size for which the enclosure is designed. (7.2.3.7)

For recreational use ONLY. Not for professional use.
User weight limit for 12ft and larger trampolines and enclosures is 200 lbs.

ASSEMBLY AND INSTALLATION INSTRUCTIONS

WARNING

Adequate overhead clearance is essential. A minimum of 24ft from ground level is recommended. Provide clearance for wires, tree limbs and other possible hazards. (7.2.3.1)(7.2.4.1)

Lateral clearance is essential. Place the trampoline and enclosure away from walls, structures, fences and other play areas. Maintain a clear space on all sides of the trampolines and enclosure. (7.2.3.2)(7.2.4.2)

Place the trampoline and enclosure on a level surface before use. (7.2.3.3)(7.2.4.3)

Use the trampoline and enclosure in a well-lighted area. Artificial illumination may be required for indoor or shady areas. (7.2.3.4)(7.2.4.3)

Secure the trampoline and enclosure against unauthorized and unsupervised use. (7.2.3.5)(7.2.4.5)

Remove any obstructions from beneath the trampoline and enclosure. (7.2.3.6)(7.2.4.3)

The trampoline enclosure is only to be used as an enclosure for a trampoline of a size for which the enclosure is designed. (7.2.3.7)

The owner and supervisors of the trampoline are responsible to make all users aware of practices specified in the user instructions. (7.2.4.7)

ASSEMBLY AND INSTALLATION INSTRUCTIONS CONTINUED

⚠ WARNING

For safe use it is very important that the net be securely attached to the frame in the correct position prior to using the trampoline.

FIRST the net ring on top of the net needs to be placed into the plastic holders on top of the poles BEFORE connecting the bottom net with a cord to the D-rings at the edge of the mat.

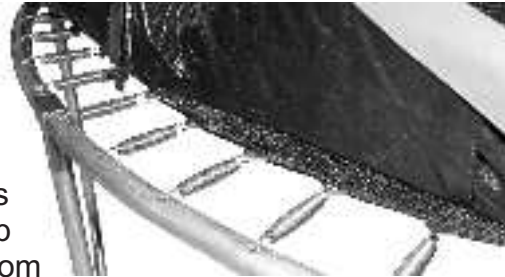

CARE AND MAINTENANCE INSTRUCTIONS

⚠ WARNING

Inspect the trampoline and enclosure before each use and replace any worn, defective or missing parts. The following conditions could represent potential hazards:

1. Missing, improperly positioned, or insecurely attached frame padding.
2. Punctures, frays, tears, or holes worn in the bed or frame padding.
3. Deterioration in the stitching or fabric of the bed or frame padding.
4. Ruptured springs.
5. A bent or broken frame and/or support system.
6. A sagging bed or barrier.
7. Sharp protrusions on the frame or suspension system. (7.3.2.1)

During extreme weather conditions, the Trampoline and enclosure can suffer an increased rate of wear beyond normal use. During prolonged periods of rain, snow, or wind, we recommend disassembly and storage

USER INSTRUCTIONS

⚠ WARNING

Inspect the trampoline before each use, make sure the barrier and the enclosure support (frame) padding is correctly and securely positioned. Replace any worn, defective, or missing parts. (7.5.1.4)

Users may become entangled in or strangled by loose cords or in gaps between trampoline and enclosure. (7.5.1.5)

Keep enclosure tightly fastened to the trampoline in accordance with the manufacturer's instructions. Failure to properly assemble and maintain a tight, secure trampoline/enclosure boundary may result in serious injury, strangulation, or death. (7.5.1.6)

Do not attempt to jump over the barrier. (7.5.1.7)

Do not attempt to crawl under the barrier. (7.5.1.8)

Do not intentionally rebound off the barrier. (7.5.1.9)

Do not hang from, kick, cut, or climb on the barrier. (7.5.1.10)

Wear clothing free of drawstrings, hooks, loops or anything that could get caught while using the trampoline/enclosure and result in entanglement or strangulation, or both. (7.5.1.11)

Do not attach anything to the barrier that is not a manufacturer-approved accessory or part of the enclosure system. (7.5.1.12)

Enter and exit the enclosure at the enclosure door or barrier opening designated for that purpose. (7.5.1.13)

⚠ WARNING

THE ENCLOSURE SUPPLIED WITH THIS TRAMPOLINE IS AN INTEGRAL PART OF THE OVERALL STRUCTURE. THE ENCLOSURE MUST BE ATTACHED TO THIS TRAMPOLINE AND ALL ASSEMBLY STEPS MUST BE FOLLOWED COMPLETELY, PRIOR TO USE.

FAILURE TO ATTACH THE ENCLOSURE WILL RESULT IN A TRAMPOLINE THAT IS NOT COMPLETELY ASSEMBLED AND USE OF THE TRAMPOLINE WHEN IT IS NOT COMPLETELY ASSEMBLED MAY RESULT IN SERIOUS INJURY, OR DEATH.

USER INSTRUCTIONS CONTINUED

⚠ WARNING

DO NOT attempt or allow somersaults on the trampoline. Landing on the head or neck can cause serious injury, paralysis, or death, even when landing in the middle of the bed. (7.5.1.1)

Do not allow more than one person inside the trampoline enclosure. Use by more than one person at the same time can result in serious injuries (7.5.1.2)

Use trampoline and enclosure only with mature, knowledgeable supervision. (7.5.1.3)

Trampolines over 20 inch (51cm) tall are not recommended for children under 6 years of age. (7.5.1.4)

Inspect the trampoline before each use. Make sure the frame padding is correctly and securely positioned. Replace any worn, defective, or missing parts. (7.5.1.5)

Climb on and off the trampoline. It is a dangerous practice to jump from the trampoline to the floor or ground when dismounting, or to jump onto the trampoline when mounting. Do not use the trampoline as a springboard to other objects. (7.5.1.6)

Stop bounce by flexing knees as feet come in contact with the trampoline bed. Learn this skill before attempting others. (7.5.1.7)

Learn fundamental bounces and body positions thoroughly before trying more advanced skills. A variety of trampoline activities can be carried out by performing the basic fundamentals in various series and combinations, performing one fundamental after another, with or without feet bounces between them. (7.5.1.8)

Avoid bouncing too high. Stay low until bounce control and repeated landing in the center of the trampoline can be accomplished. Control is more important than height. (7.5.1.9)

While keeping the head erect, focus eyes on the trampoline toward the perimeter. This will help control bounce. (7.5.1.10)

Avoid bouncing when tired. Keep turns short. (7.5.1.11)

Properly secure the trampoline when not in use. Protect it against unauthorized use. If a trampoline ladder is used, the supervisor should remove it from the trampoline when leaving the area to prevent unsupervised access by children under 6 years of age. (7.5.1.12)

Keep objects away which could interfere with the performer. Maintain a clear area around the trampoline. (7.5.1.13)

Do not use the trampoline while under the influence of alcohol or drugs (7.5.1.14)

USER INSTRUCTIONS CONTINUED

⚠ WARNING

For additional information concerning the trampoline equipment, contact the manufacturer. (7.5.1.15)

For information concerning skill training, contact a certified trampoline instructor. (7.5.1.16)

Bounce only when the surface of the bed is dry. Wind or air movement should be calm to gentle. The trampoline must not be used in gusty or severe winds. (7.5.1.17)

Read all instructions before using the trampoline and/or trampoline enclosure. Warnings and instructions for the care, maintenance and use of this trampoline are included to promote safe, enjoyable use of this equipment. (7.5.1.18)

OWNER'S AND SUPERVISOR'S ROLE IN PREVENTING INJURIES AND RESPONSIBILITIES

The jumper must first learn all of the basic, fundamental bounces before attempting more difficult ones. Low, controlled bounces are a good start before learning the basic landing positions and combinations. Jumpers need to understand that control is the key to a successful jump. Review of the users' manual to learn basic techniques is a must. Following the tips in the placard is also important. Contact a certified trampoline instructor for more information.

USER'S ROLE PREVENTING INJURIES AND RESPONSIBILITIES

The supervisor's role is to make sure the users know all the safety rules as well as learn the basic, fundamental bounces. They need to enforce all the safety rules and warnings in the manual, frame and labels. When a supervisor is not available, the trampoline may be dis-assembled or covered to limit access. It is the supervisor's responsibility that the placard with the trampoline safety tips is placed where all jumpers are informed about the tips.

TRAMPOLINE SAFETY AND ACCIDENT PREVENTION

As most recreational sports, participants may be injured. This section covers the common accidents. Responsibilities of the supervisors and jumpers in accident prevention are also outlined.

The following are reasons why accidents happen:

Attempting somersaults. Landing on the head or neck can cause serious injury, paralysis, or death, even when landing in the middle of the bed.

More than one person on the trampoline. Use by more than one person at the same time can result in serious injuries.

Incorrect mounting and dismounting. Carefully crawl out of and into the trampoline bed. Do not jump off to the ground. Do not jump from a roof, or other object onto the trampoline. Small children may need assistance to get on or off the trampoline. Do not step onto the suspension system.

Hitting the frame. Stay in the center of the trampoline when jumping. Injury may result from hitting the frame when control is lost. Be sure the frame cover is always on and the pads securely fastened. Do not jump directly onto the frame pad.

Loss of control. A jumper who loses control will increase his/her chance of injury. Be sure to familiarize yourself with the basic jumps before doing more difficult ones. Jumps should be mastered, performed repeatedly before moving on to the next level. To regain control and stop your jump, bend your knees sharply as you land.

Alcohol and drug use. Because alcohol and drug use impairs the jumpers' coordination, loss of control as well as injuries are greatly increased.

Foreign objects. Please make sure there is nothing sharp under and around the trampoline. Hitting objects under the trampoline can cause injury. Jumping with a foreign object can also increase the chances of getting injured. Be sure there is adequate clearance 24 ft. above and 10 ft. around the trampoline. Be careful of overhead wires, tree limbs etc.

Bad weather. Do not use your trampoline in gusty winds or inclement weather. The bed should not be wet.

Poor maintenance of the trampoline. Make sure you inspect the trampoline before every use. Check for punctures on the bed, sharp burrs on the frame, stitching that has gone bad or loose elastic bands. If a replacement part is needed, please call our hotline to order.

Unlimited access. The trampoline should be covered or dis-assembled when not in use. This will prevent unsupervised small children from using the trampoline.

FUNDAMENTAL BOUNCES

STANDING BOUNCE

1. Start in the center of bed, feet shoulder width apart, arms at side, eyes on end of bed.
2. As you jump from trampoline, arms come up and forward, circling outward and back to side as you again contact bed. Bring feet together, toes pointed, in the air, feet shoulders-width apart again as you contact bed. Arms need never go above your shoulders or behind your body.



KNEE BOUNCE

1. First, assume kneeling position in center of bed, back straight, eyes on end of bed.
2. Pump your way to your feet by bouncing, using your arms as in standing bounce.
3. Duplicate position from a low bounce

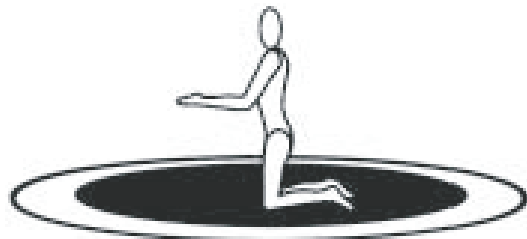

HANDS AND KNEE DROP

1. First, assume position shown in illustration, keeping head up, eyes on end of bed.
2. Duplicate position from a low bounce. Keep your hands as close to your knees as shown in illustration.



FRONT DROP

1. First, assume position of hands and knee bounce. Begin to bounce slightly in this position, then kick legs back, land on stomach, taking some weight on bent forearms as shown in illustration. Make sure you kick backwards, do not go forward, and return to hands and knees position.
2. Try from a low bounce, kicking backwards making your belt land where your feet were.

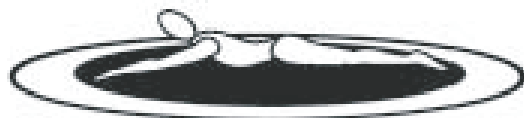

FUNDAMENTAL BOUNCES

SEAT DROP

1. First, assume sitting position in center of bed, legs spread wide, hands on bed, leaning slightly forward.
2. Duplicate this position from a low bounce. To come to your feet again, be sure to lean forward and press bed with your hands.

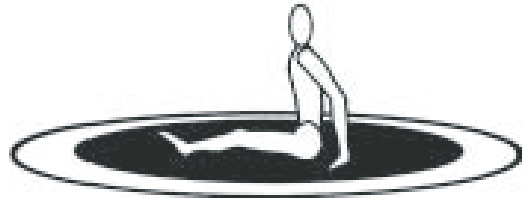

PIROUETTE

1. HALF PIROUETTE:
Done like a standing bounce, but at top of bounce, swiftly turn head and search for opposite end of trampoline. Do not travel. Land on feet.
2. FULL PIROUETTE:
Done as above, but continue around, until a complete circle has been made. Spot by looking for end bars as you complete trick.



BACK DROP

1. Lie on your back on bed, spread your legs slightly and raise them about 45 degrees from the surface of the bed, raise your arms to corresponding angle, raise head and look at end of trampoline. This is your landing position.
2. Try cautiously from a low bounce, making sure you do not lose sight of end bar of trampoline at any time. Weight should be taken more on your shoulders than on your hips.

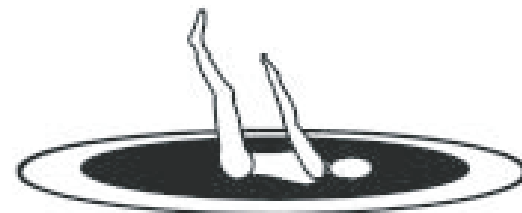

TUCK POSITION

Done like a standing bounce, but at top of bounce, bring knees to chest and grasp with arms. Then lower feet to contact bed.



FUNDAMENTAL BOUNCES

PIKE POSITION

Done like a standing bounce, but at top of bounce , keeping knees locked and toes pointed, raise legs as illustrated, then lower feet to contact bed.



LAYOUT POSITION

Done like a standing bounce, but at top of bounce , stretch slightly, arching back, and momentarily looking skyward.

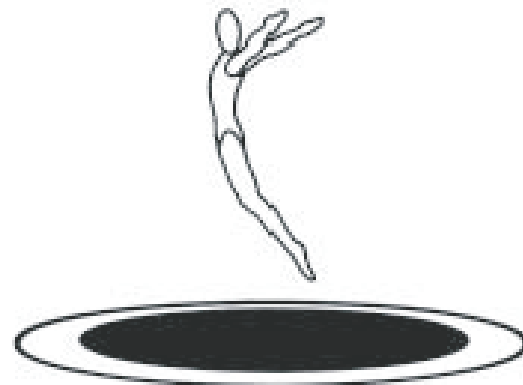

STRADDLE POSITION

Done like pike bounce, but with legs spread as widely as is comfortable. Reach for your toes!



TRAMPOLINE AND ENCLOSURE ASSEMBLY

REFER TO PARTS LIST FOR IDENTIFICATION OF PARTS

WARNING: 2-3 adults in good physical condition are required for the following assembly. Wear proper shoes and maintain balance to prevent a fall. Failure to follow all instructions and warnings exactly may result in serious injury. Do not use your trampoline and/or enclosure until you have thoroughly read and understand all instructions and warnings provided.

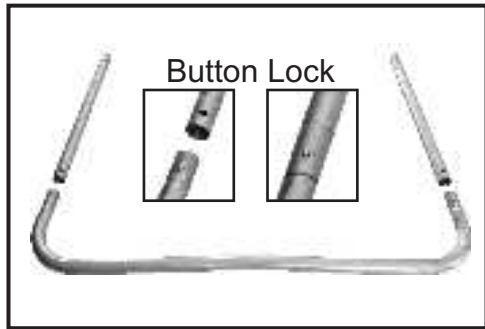

1. Attach each of the two leg extensions(E) to the “W” shaped leg(F). The leg extensions are secured to the “W” shaped leg by way of a button lock.

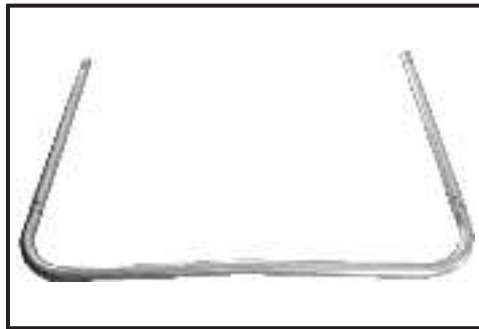

2. Repeat step 1 with the remaining “W” shaped legs(F) and leg extensions(E). Properly assembled, each leg assembly should look like this.

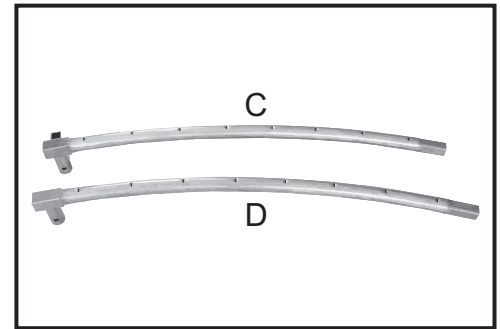

3. To assemble the top rail, pick out the two different rail tubes C and D.

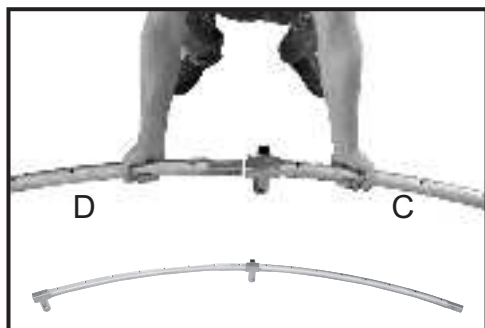

4. Slide one end of rail tube C onto rail tube D like this.

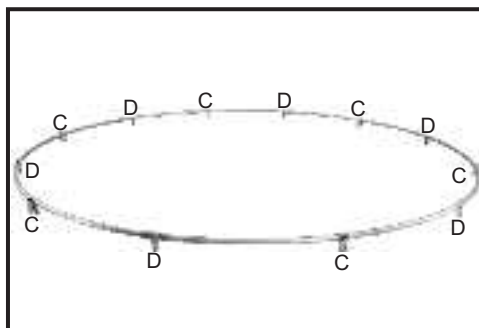

5. Continue step 4 by sliding the balance top rail tubes together, until a large circle is formed. Joining the final segments together may require three adults in good physical condition. With one person holding the opposite side, bring both ends of the circle firmly together.

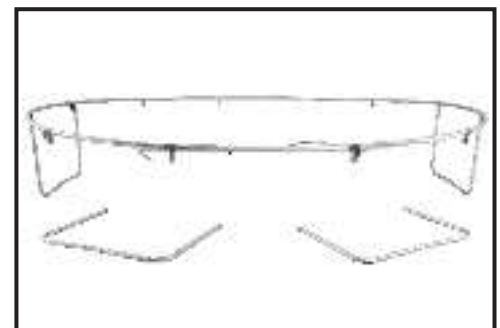

6. Insert the leg assemblies into the “T” connectors of the top rail.

TRAMPOLINE AND ENCLOSURE ASSEMBLY

REFER TO PARTS LIST FOR IDENTIFICATION OF PARTS

WARNING: 2-3 adults in good physical condition are required for the following assembly. Wear proper shoes and maintain balance to prevent a fall. Failure to follow all instructions and warnings exactly may result in serious injury. Do not use your trampoline and/or enclosure until you have thoroughly read and understand all instructions and warnings provided.



7. Example of leg assembly fixed into the "T" connector of top rail, secured with button lock. Please make sure the button lock face inside.

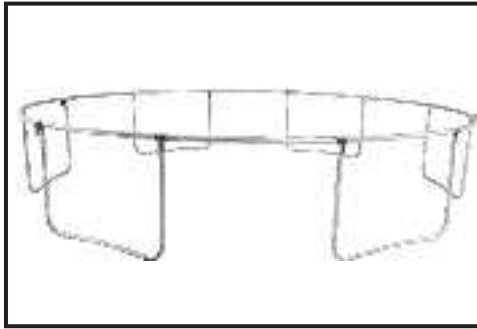

8. Continue with all the legs, after which the trampoline should look like this.

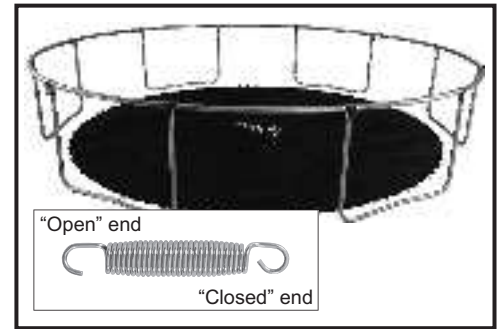

9. With stitching portion facing downward and labels + logo facing upwards, lay jump mat (B) inside the frame and attach a spring (G) to a "D" ring on the mat. Always attach "closed" end of hooks to the jump mat "D" rings and "open" end of hooks to the top rail.



10. Attach initial spring into a slot on the top rail. **WARNING:** Trampoline is under tension and effort may be required to attach springs to frame. Be careful not to pinch fingers or slip. Serious injury may occur!



11. Repeat this step directly across from where you attached the first spring. You will have to count to make sure that the correct "D" ring is the same number of slots away from the starting point.



12. Attach four more springs equal the distance from each other. Count to make sure "D" rings and slots are aligned.

TRAMPOLINE AND ENCLOSURE ASSEMBLY

REFER TO PARTS LIST FOR IDENTIFICATION OF PARTS

WARNING: 2-3 adults in good physical condition are required for the following assembly. Wear proper shoes and maintain balance to prevent a fall. Failure to follow all instructions and warnings exactly may result in serious injury. Do not use your trampoline and/or enclosure until you have thoroughly read and understand all instructions and warnings provided.

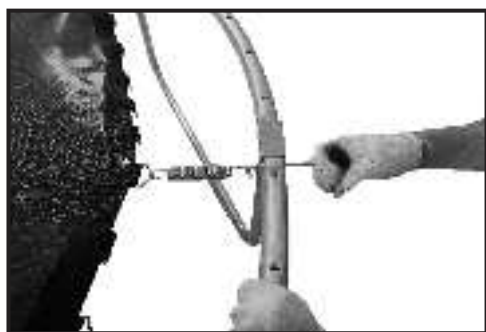

13. As you add springs the tension will increase. Use the spring tool(H) to safely hook the ends of each spring into the rail as shown.



14. Repeat the process of placing the springs half the distance among the already placed springs. To even out tension, attach a spring opposite the one just attached.

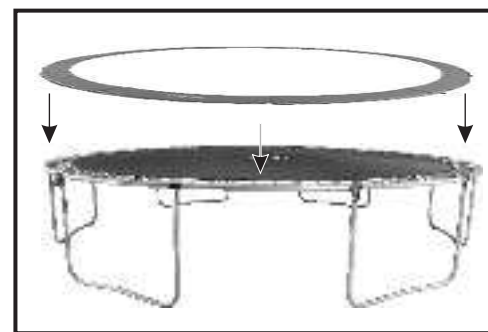

15. With all springs attached, lay frame cover(A) in place.



16. Position the frame cover(A) over the top rail and springs, whilst making sure that each gap in the padding aligns with the "T" connector on the top rail, in which the enclosure pole will be placed (See step 22). Do NOT fasten the frame cover to the frame at this moment.

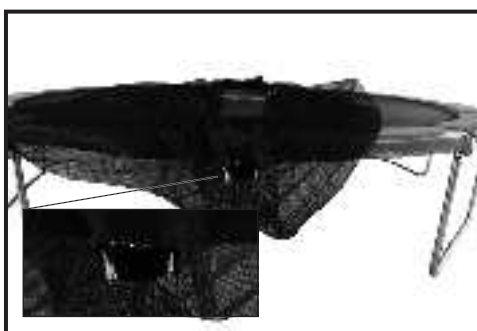

17. Spread out the Enclosure Mesh Net(O) on the trampoline and guide the steel rods(M) through the "tunnel" stitched in the top of the net.

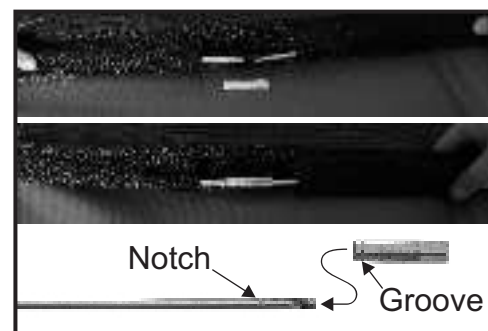

18. While guiding the steel rods (M) through the "tunnel", connect each of the steel rods with Connection Nut(N) until a full circle has formed. The metal nut can be fastened by hand or with help of a wrench (P).
Attention: Side with "groove" in nut needs to be connected with "notch" side in steel rod.

TRAMPOLINE AND ENCLOSURE ASSEMBLY

REFER TO PARTS LIST FOR IDENTIFICATION OF PARTS

WARNING: 2-3 adults in good physical condition are required for the following assembly. Wear proper shoes and maintain balance to prevent a fall. Failure to follow all instructions and warnings exactly may result in serious injury. Do not use your trampoline and/or enclosure until you have thoroughly read and understand all instructions and warnings provided.

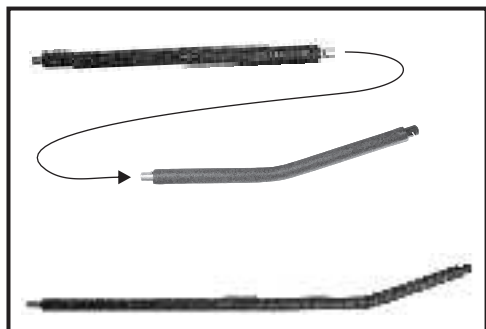

19. Connect lower pole(K) with upper pole(J) until button lock is locked in place. Do this for all six enclosure poles.

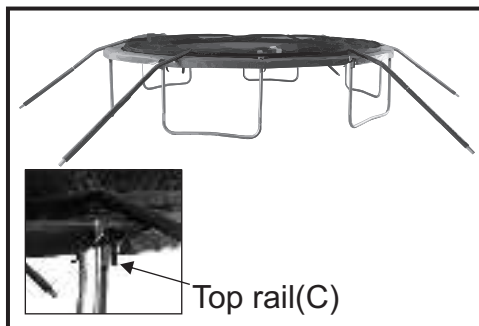

20. Divide the six enclosure poles around the trampoline and place them near top rail(C) as per the image above, after which each of the enclosure poles should be connected to the steel rod circle at the top of the enclosure net.



21. Enclosure poles are connected to the steel rod circle as per the image above.



22. Carefully place the enclosure poles into the "T" connectors on the top rail until all 6 poles are fixed in place.



23. Find the enclosure entrance and pull it firmly down. Then align the zipper in between two of the enclosure poles. Locate the nearest metal "D" ring which is stitched to the jump mat. Start fastening the enclosure to the jump mat by threading the cord as shown in step 24.



24. Tie one cord-end(L) to the "D-ring" nearest to the enclosure entrance and thread the other end through the nearest cord hole in the bottom of the enclosure net. Then continue to thread the cord through each "D-ring" and nearest cord holes in the bottom of the net until the enclosure has been fastened to each of the "D-rings" For enlarged view see point 25

TRAMPOLINE AND ENCLOSURE ASSEMBLY

REFER TO PARTS LIST FOR IDENTIFICATION OF PARTS

WARNING: 2-3 adults in good physical condition are required for the following assembly. Wear proper shoes and maintain balance to prevent a fall. Failure to follow all instructions and warnings exactly may result in serious injury. Do not use your trampoline and/or enclosure until you have thoroughly read and understand all instructions and warnings provided.

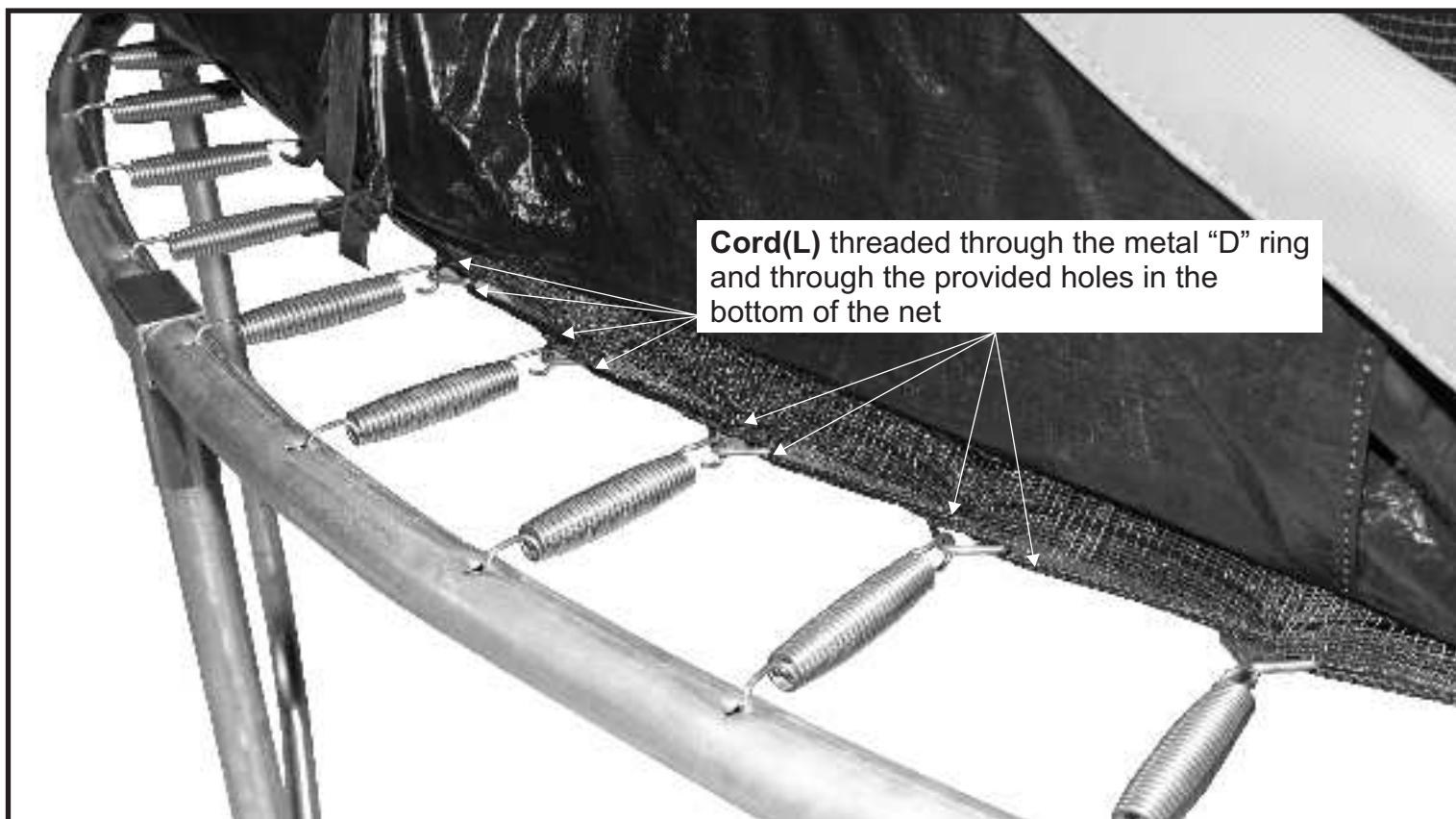

25. Enlarged view of threading enclosure to jumping mat

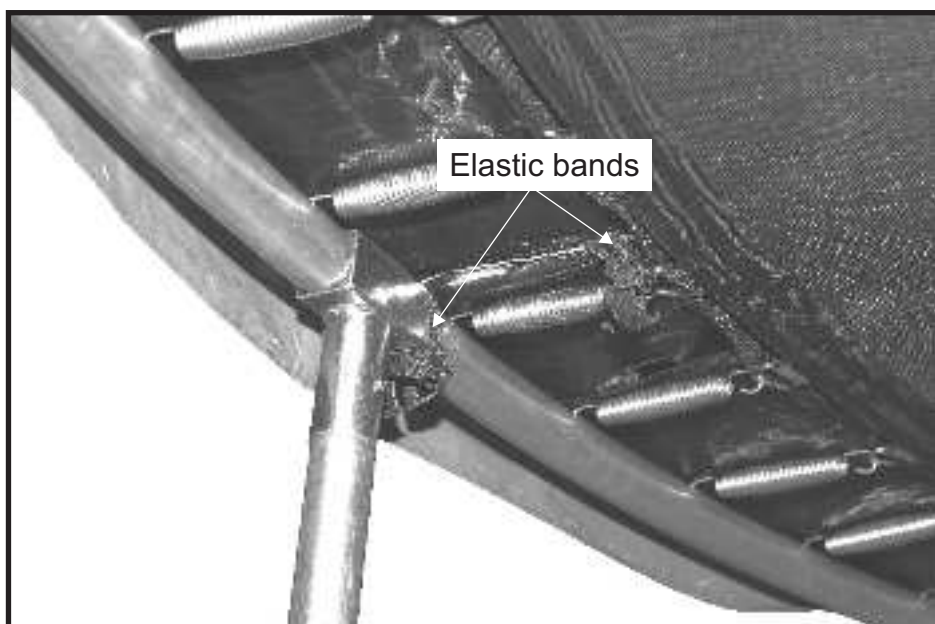

26. Now tie the PVC Frame Cover(A) with elastic bands to the frame as per the image above.

LIMITED WARRANTY

DO NOT RETURN TO PLACE OF PURCHASE

Subject to the following limitations, in addition to any imposed by virtue of applicable law, Airzone warrants this trampoline and/or safety enclosure to be free from defects in materials and workmanship under normal use and service conditions.

The tubular steel frame is warranted for three(3) years after the date of purchase. All other parts are warranted for one(1) year after the date of purchase. This warranty is limited to the repair and/or replacement of defective parts only. All requests for missing parts must be pre-authorized by calling customer service within 30 days of the date of purchase and must be accompanied by an original receipt from an authorized dealer.

Certain regions of the country have environmental conditions that are extremely hard on trampolines or enclosures of any kind. If you live in Arizona, Florida, Nevada, New Mexico, Texas or in high altitudes (above 3,000 feet), the warranty period for your item will be limited to six months from the date of original purchase. (After expiration of that six months period and up to a period of one year following date of original purchase, you may purchase replacement parts at a reduced price from our customer service department.)

1. This limited warranty will apply only if the part(s) are returned freight pre-paid to the customer service department listed below and are accompanied by both an original receipt from an authorized dealer and the serial number found on the frame or instruction manual, and if Airzone, at its sole discretion, determines it (them) to be defective.
2. This limited warranty will apply only to Airzone trampolines and/or enclosures that are purchased from an authorized dealer. This limited warranty is extended only to the original consumer purchaser and is not transferable.
3. Be sure to retain your original purchase sales receipt and instruction manual for any warranty claim. The instruction manual has a serial number on PAGE 2 of the IM (a duplicate of which is also found on one of the tubular steel components) that is required from all missing parts and warranty claims. All warranty claims must be accompanied by the original purchase receipt from an authorized dealer and this serial number.
4. Before returning any parts to Airzone for warranty inspection, the original consumer purchaser must obtain an RMA number (Return Merchandise Authorization number) from Airzone. Such authorization can be obtained by calling our customer service department at the toll-free number listed below or by writing to the Airzone customer service department at the address listed below. The original consumer purchaser is responsible for all shipping costs.
5. Upon receipt of authorization from our customer service department, you must submit your warranty claim to the address below, ship parts freight pre-paid, accompanied by the original and dated purchase receipt with the serial number from the manual or frame written on it. Do not return this product to the place of purchase. For warranty service or for missing or replacement parts of any other problems, call or write to our customer service department at the phone number or address listed below. We will send any replacement parts via FedEx Ground.
6. This limited warranty does not cover damage or loss from: wind, rain, fire, ice, or other forces of nature; accident; normal wear; improper assembly, disassembly, or adjustment during set-up or take-down; or any abuse, neglect or misuse of this trampoline, enclosure and/or its parts. Any alteration to the original product voids this warranty.

LIMITED WARRANTY

DO NOT RETURN TO PLACE OF PURCHASE

7. To the extent allowed by applicable law, any implied warranty of merchantability or fitness applicable to this Airzone trampoline and/or enclosure is limited to the duration of this limited warranty. Airzone does not warrant against, and in no event shall Airzone or its authorized agents be liable for any personal loss, injury, direct or indirect incidental or consequential damage resulting from use of this product. Please note that some states do not allow the exclusion or limitation of incidental or consequential damages, so the above limitation of exclusion may not apply to you. This limited warranty gives you specific legal rights and you may have other rights which vary from state to state.
8. Do not allow more than one person on the trampoline or inside the trampoline enclosure. Use by more than one person at the same time can result in serious injury and will void the warranty. This limited warranty is null and void if the “care and maintenance” instructions on page 5 and the “user instructions” on pages 6-8 of this manual are not followed prior to each use of the trampoline.

Distributed by Airzone Ltd.

Questions, Comments or Warranty Claims:
Call 1-800-775-6524

or

MAIL CustomerService@airzone-na.com