

-02P2

Montageanweisung / Installation instructions / Instruction de montage / Istruzioni di montaggio
montagehandleiding / Instrukcja montażu / Montaj talimatlar / Osszeszerelési útmutató / Nàvod k montáži /
Nàvod na montaž / Instrucțiune de montaj / Инструкция по монтажу / Montaj talimatina / Monteringsanvisningar
Upute za montažu / Instrucciones de Montaje / Navodila za montažo

SHEYLA

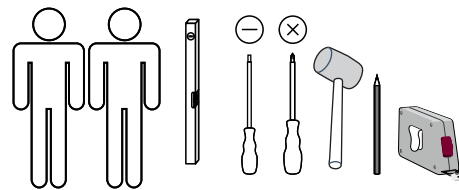
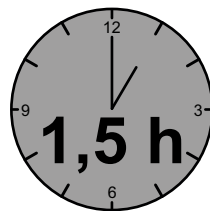

LC S.p.A
Via del Piano s.n
61030 Isola del Piano (PU)
Italia
<http://www.lcmobili.com/>

D – bitte lesen sie diese montageanleitung gut durch,
Da wir für fehler, die durch falsche montage entstehen,
Keine haftung übernehmen!

Gb – please read these installation instructions
Through carefully as we cannot accept any liability
For faults occurring as a result of incorrect installation!

Cz – přečtete si prosim pozorně tento návod k montáži,
Aby jste předešli chybám vzniklých špatnou montáží,
Za které neručíme!

F – veuillez lire attentivement cette notice de montage,
Car nous déclinons toute responsabilité en cas d'erreurs
Découlant d'un montage erroné !

I – prego leggere attentamente le istruzioni per il montaggio,
Poiché decliniamo qualsiasi responsabilità
Per difetti derivanti da montaggio errato.

S - läs monteringsanvisningarna noggrant.
Vi avsäger oss allt ansvar för defekter som
Uppstår p.g.a. Felaktig montering.

Hr – pažljivo pročitajte upute za montažu,
Jer otklanjamo svaku odgovornost za pogreške
Nastale uslijed pogrešne montaže.

Slo – prosimo, da pozorno preberete navodila za montažo,
Saj zavračamo vsakršno odgovornost za napake,
Ki bi nastale zaradi napačne montaže.

Nl – leest u alstublieft deze montagehandleiding goed door,
Voor fouten door verkeerde montage zijn wij niet verantwoordelijk.

Pl – prosze uwaznie zapoznac sie z instrukcja montazu,
Poniewaz nie ponosimy odpowiedzialnosci za niewlasciwy montaz.

HU – Kérjük, olvassa el figyelmesen
ezt az összeszerelési útmutatót,
mert a helytelen összeszerelésből
a dódó hibákért nem vállalunk felelősséget!

SK – Prosime, dobre prečítajte si tento návod na montáž,
pretože nepreberáme žiadne ručenie za chyby,
ktoré vzniknú na základe chybnej montáže!

RO – Vă rugăm să cititi cu atenție aceste instrucțiuni
de montaj deoarece nu preluăm garanția pentru defecte
ce apar datorită unui montaj incorect!

RUS – Пожалуйста, внимательно ознакомьтесь ù
с данной инструкцией по монтажу, поскольку мы не
несем ответственности за ошибки, причиной которых
является неправильный монтаж.

TU – İlkonce kullanma klavuzunu iyi okuyun,
yalnis montaj yapasaniz bunun sorumlusu biz degiliz.

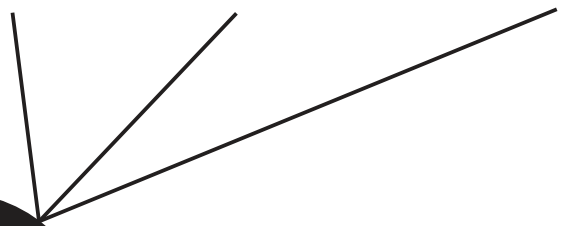

ES – Se ruega leer con atención las instrucciones
de montaje debido a que declinamos cualquier
responsabilidad
por defectos derivados de un montaje erróneo.



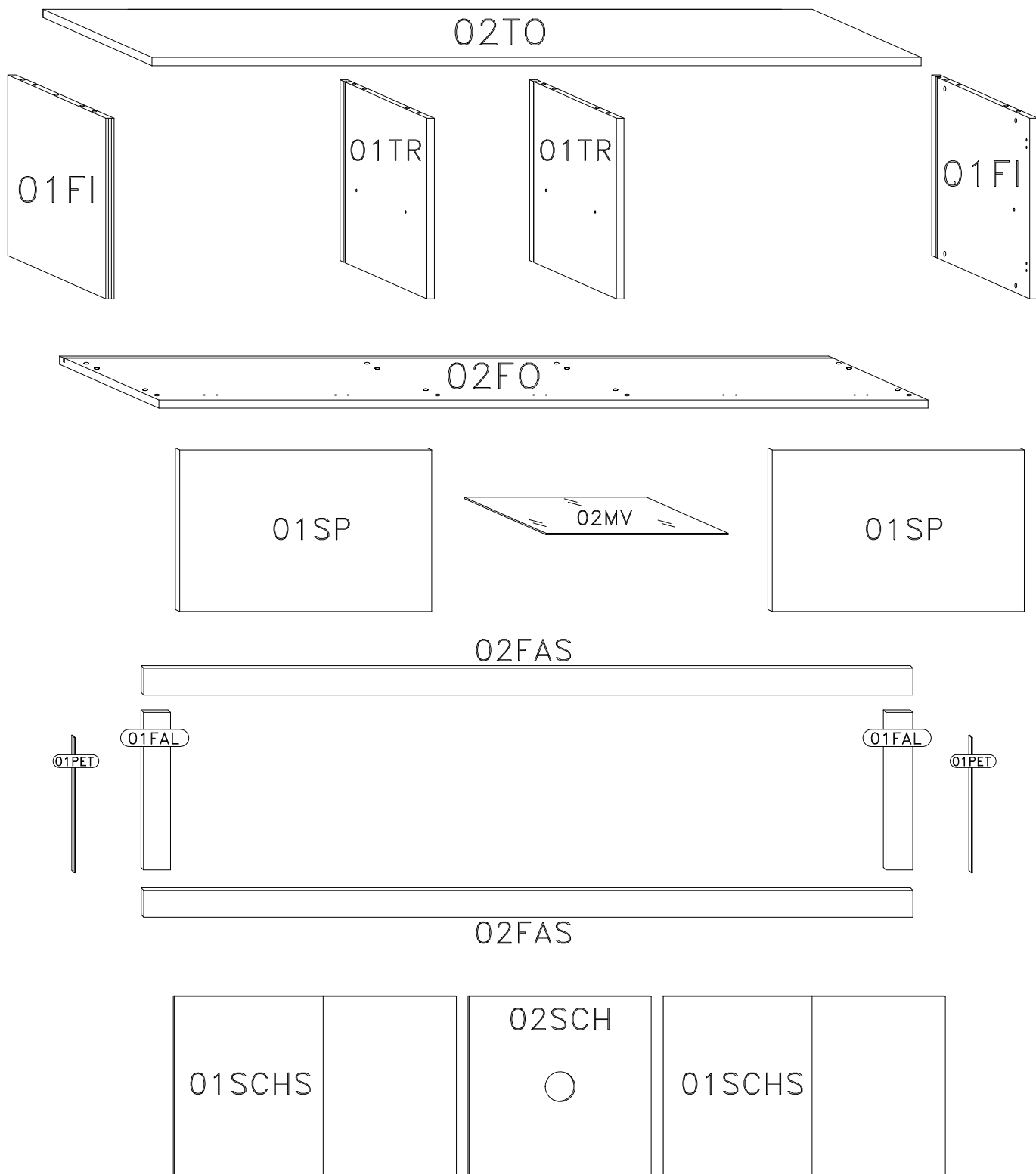

SERVICEKARTE-SPAREPARTS LIST-CARTE SERVICE-SCHEDA DI SERVIZIO
SERVICEKAART-SERVISNI KARTA-HIZMET KARTI- обслуживание карт

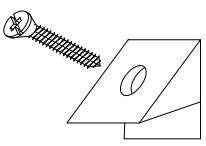
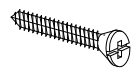
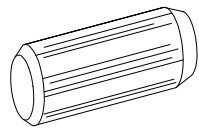
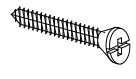
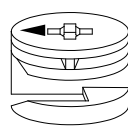
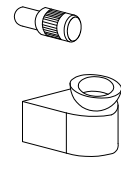
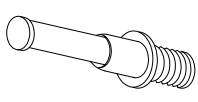
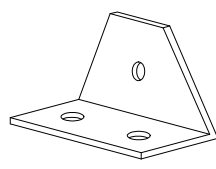
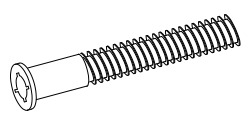

SERVICEKARTE-SPAREPARTS LIST-CARTE SERVICE-SCHEDA DI SERVIZIO
SERVICEKAART-SERVISNI KARTA-HIZMET KARTI- обслуживание карт

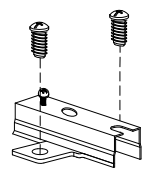
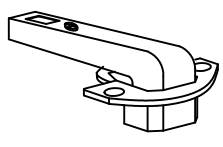
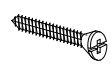
		209015-02CF	
A		x18	L
			
			4.5x30 mm. x6
B		x24	L3
8x30 mm.			
			4x18 mm. x42
C		x12	R1
∅15 mm.			
			x4
D		x12	P7
			
			x14
E		x4	P
7x60 mm.			
			x4

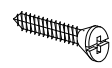
		201502-07CC	
N1		x4	
O1		x4	
L2		x8	
	4x16 mm.		

		509080-01CM	
M2		x4	
	3,5x16 mm.		
S11		x2	

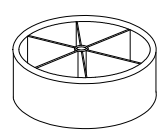
		205124-06PIE	
F21		x6	
	∅ 60 mm h 20 mm		

1

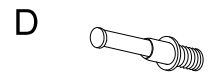
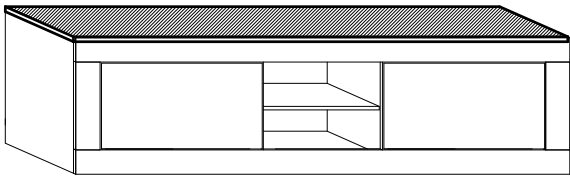

x8

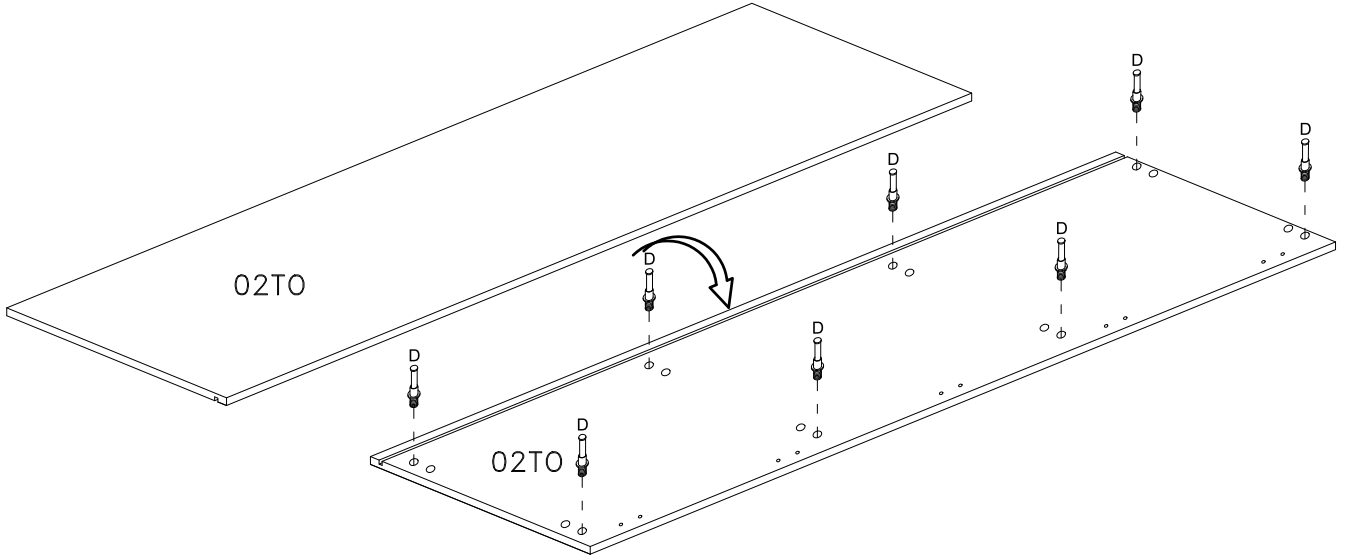

2

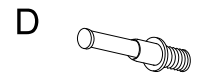
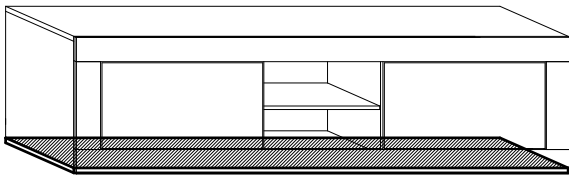

x4

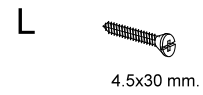

x6

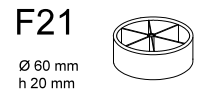

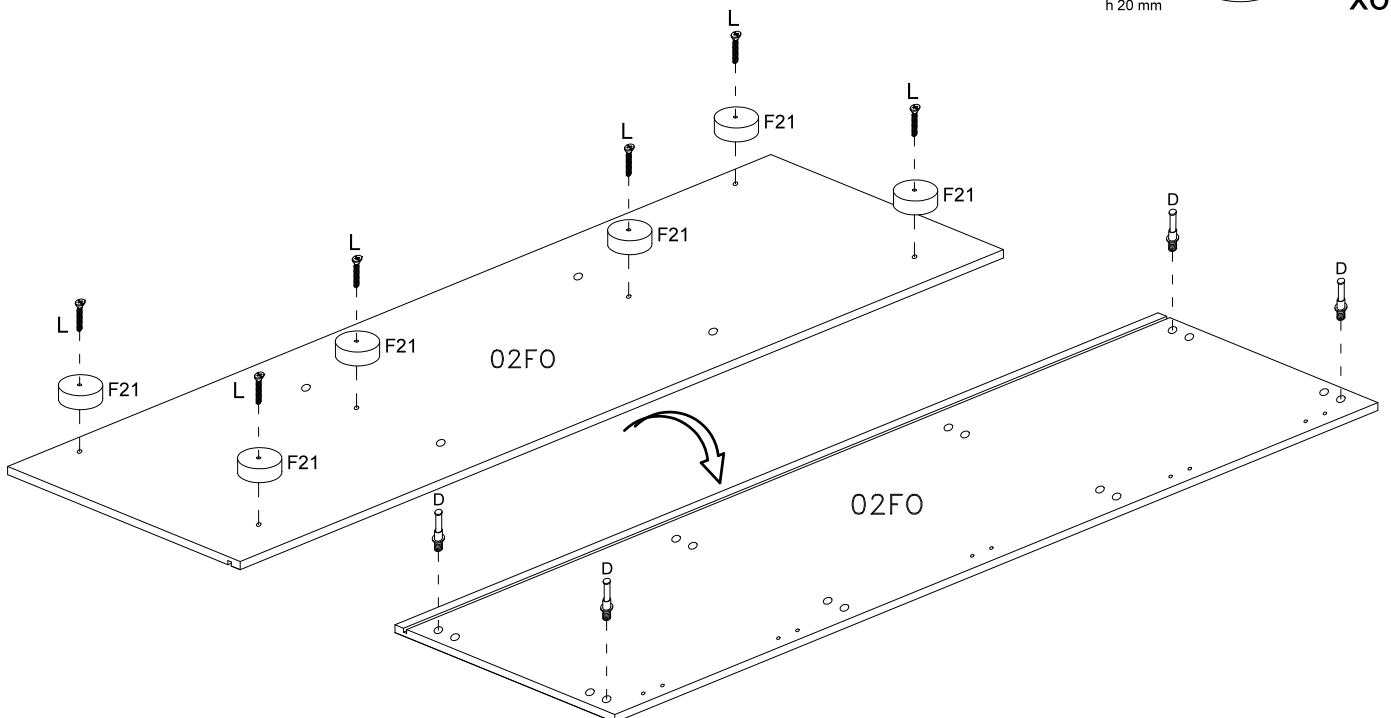

x6

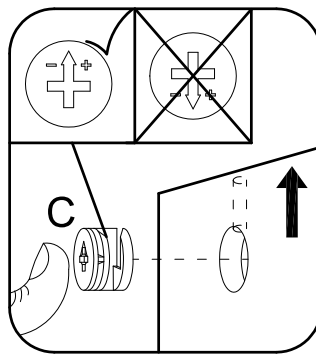
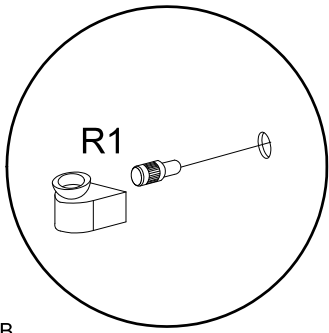

3



- B  8x30 mm. x16
- C  \varnothing 15 mm. x12
- R1  x4

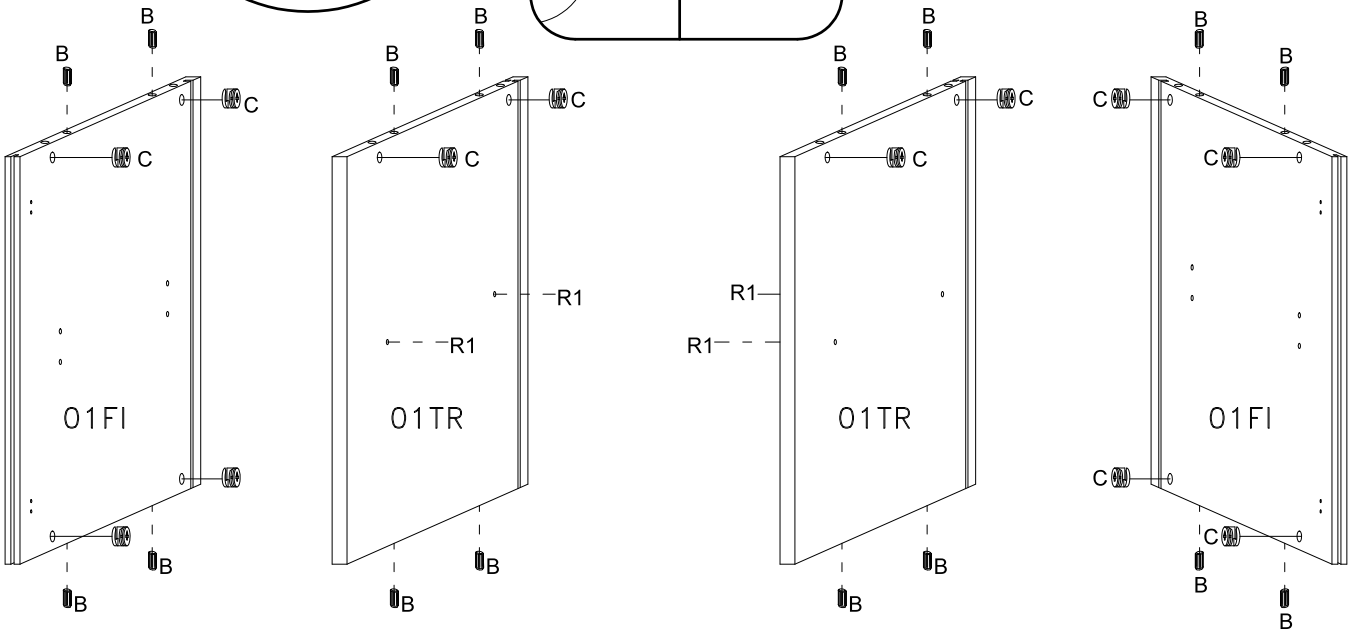

4

- E  7x60 mm. x4

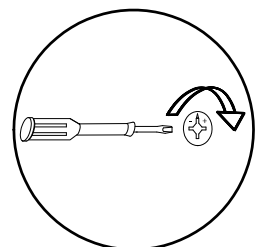
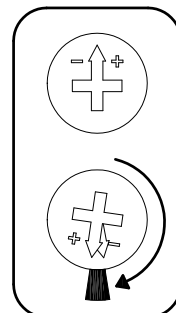
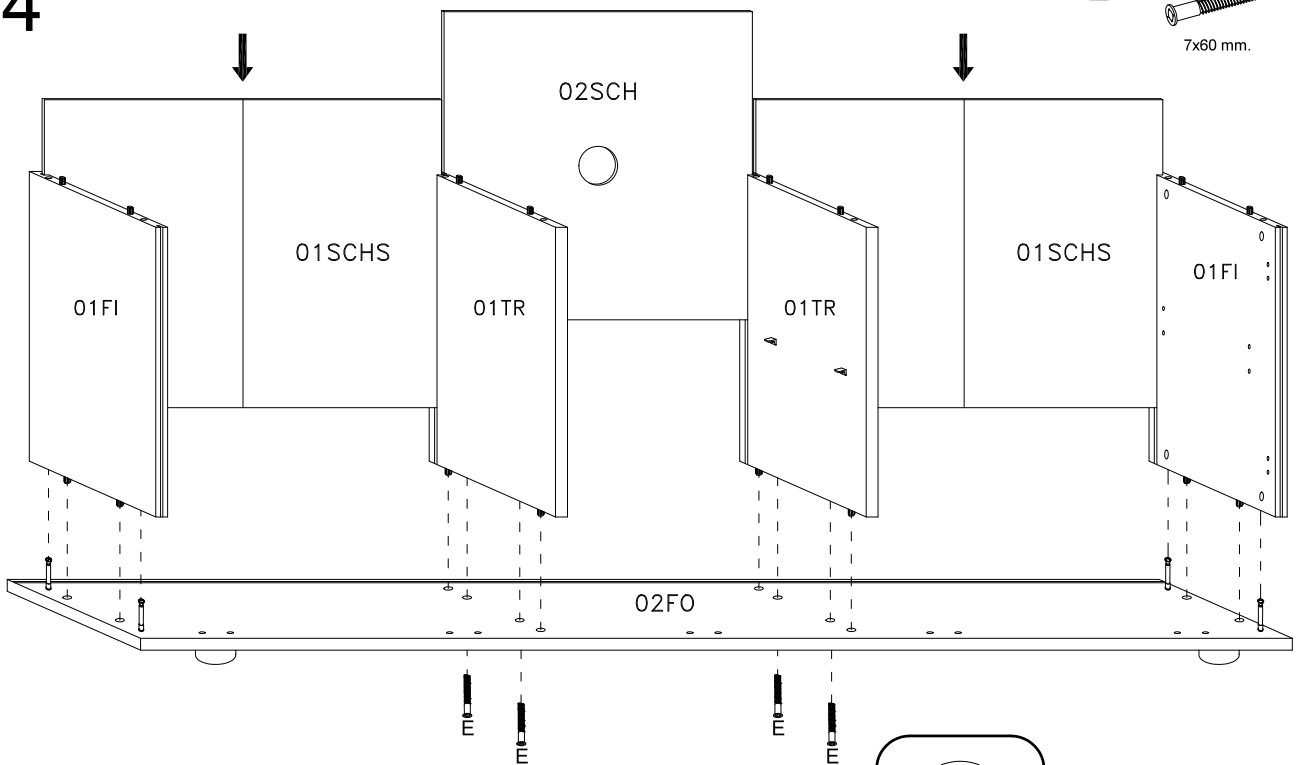

5

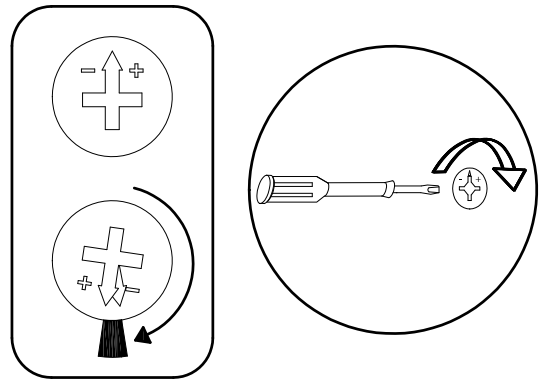
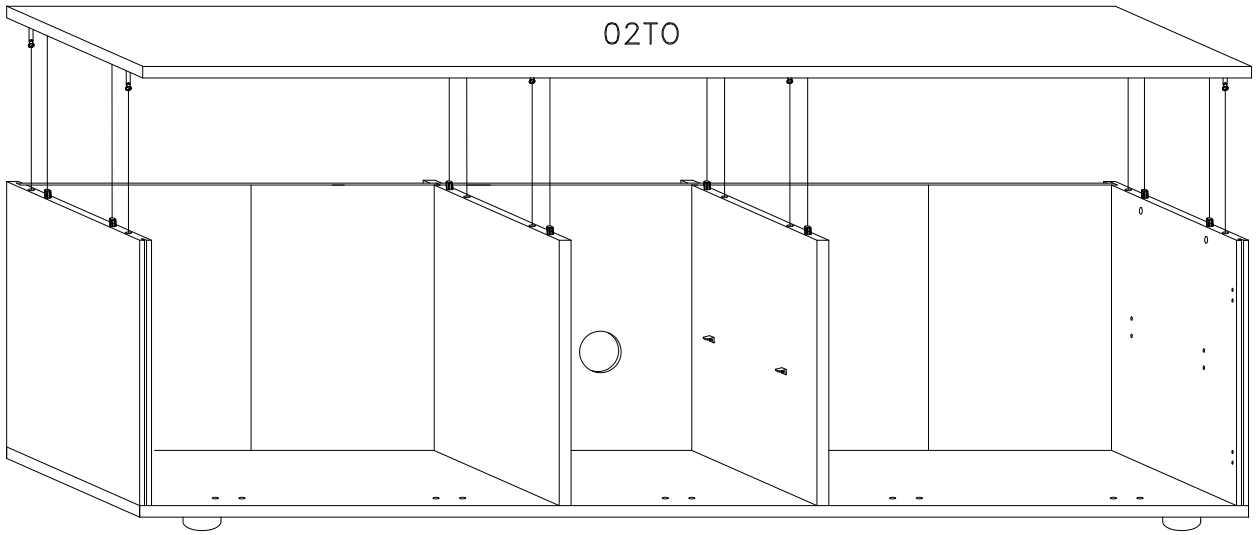

6

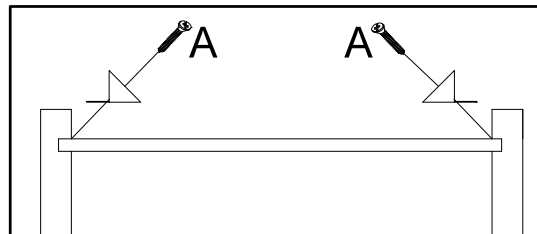

A

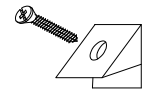



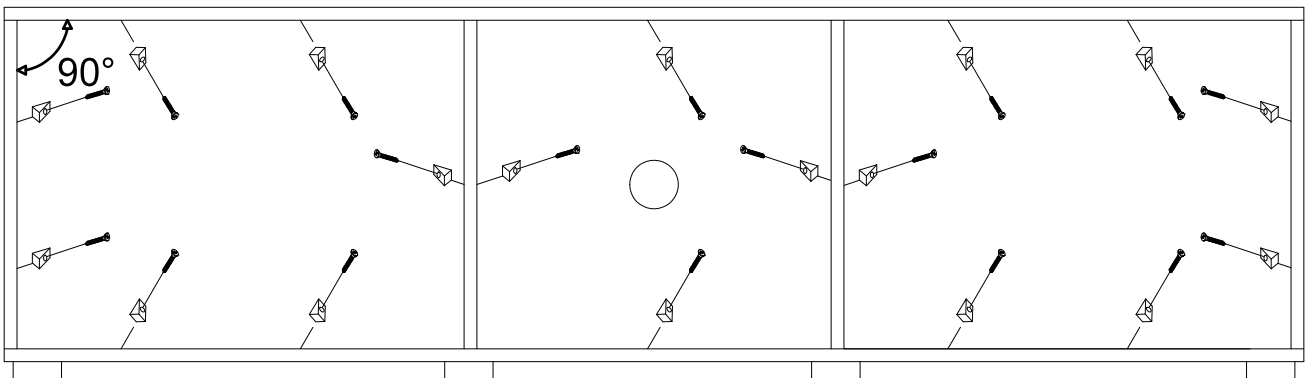

x18

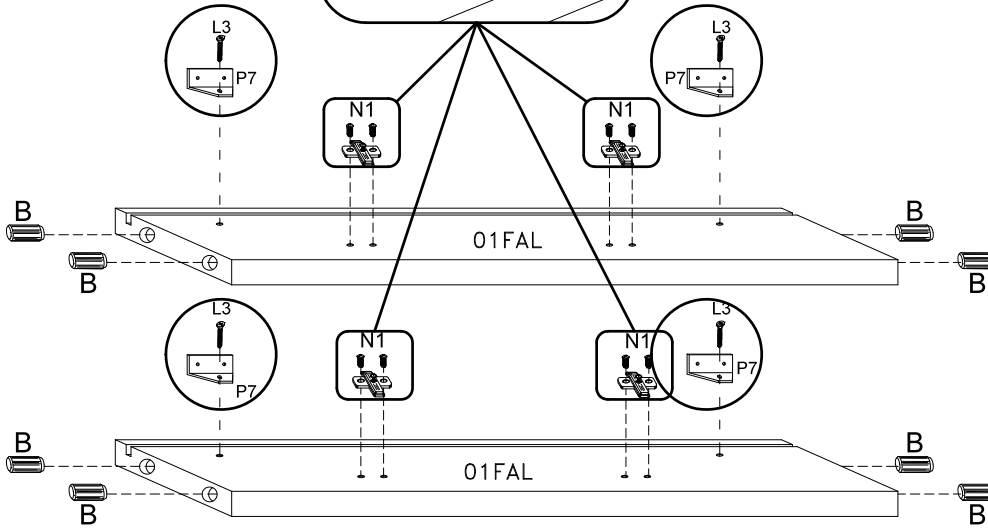
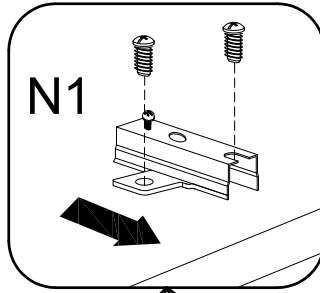
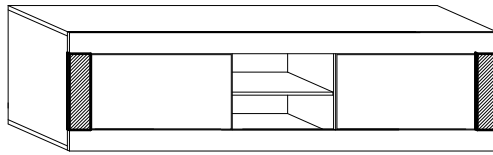
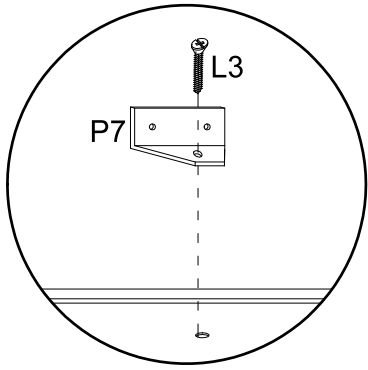

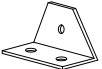

7

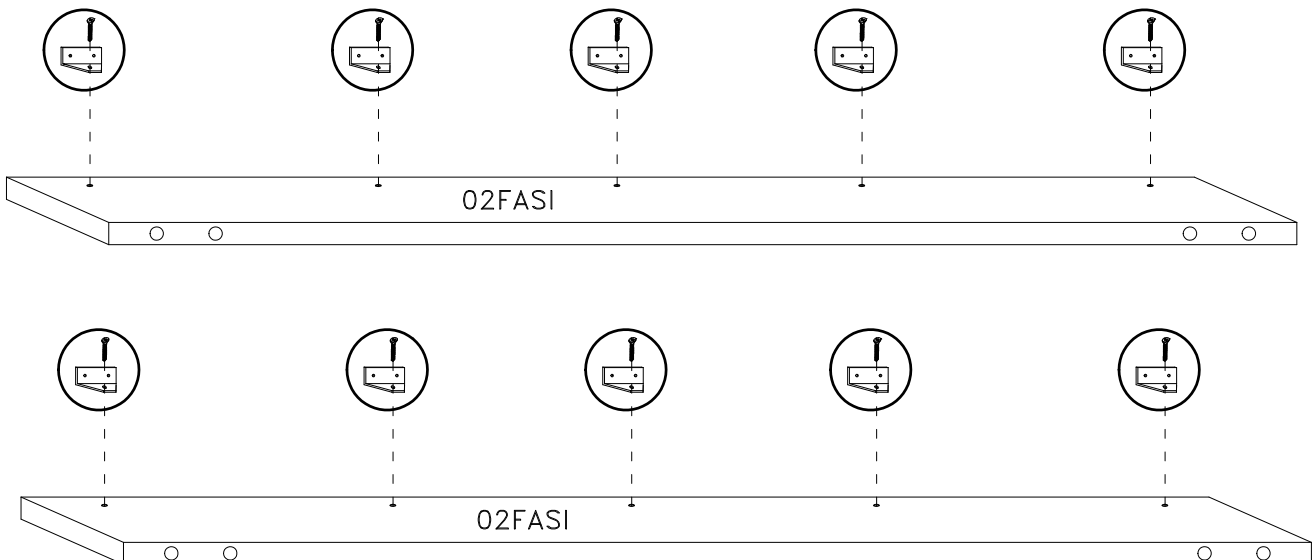
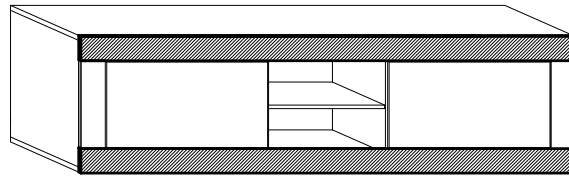
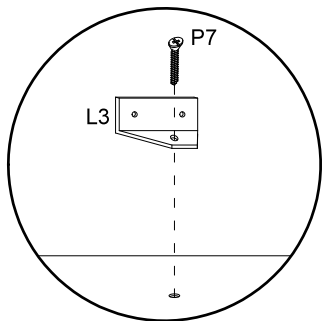

- B  8x30 mm. x8
- N1  x4
- P7  x4
- L3  4x18 mm. x4

8



- P7  x10
- L3  4x18 mm. x10

9

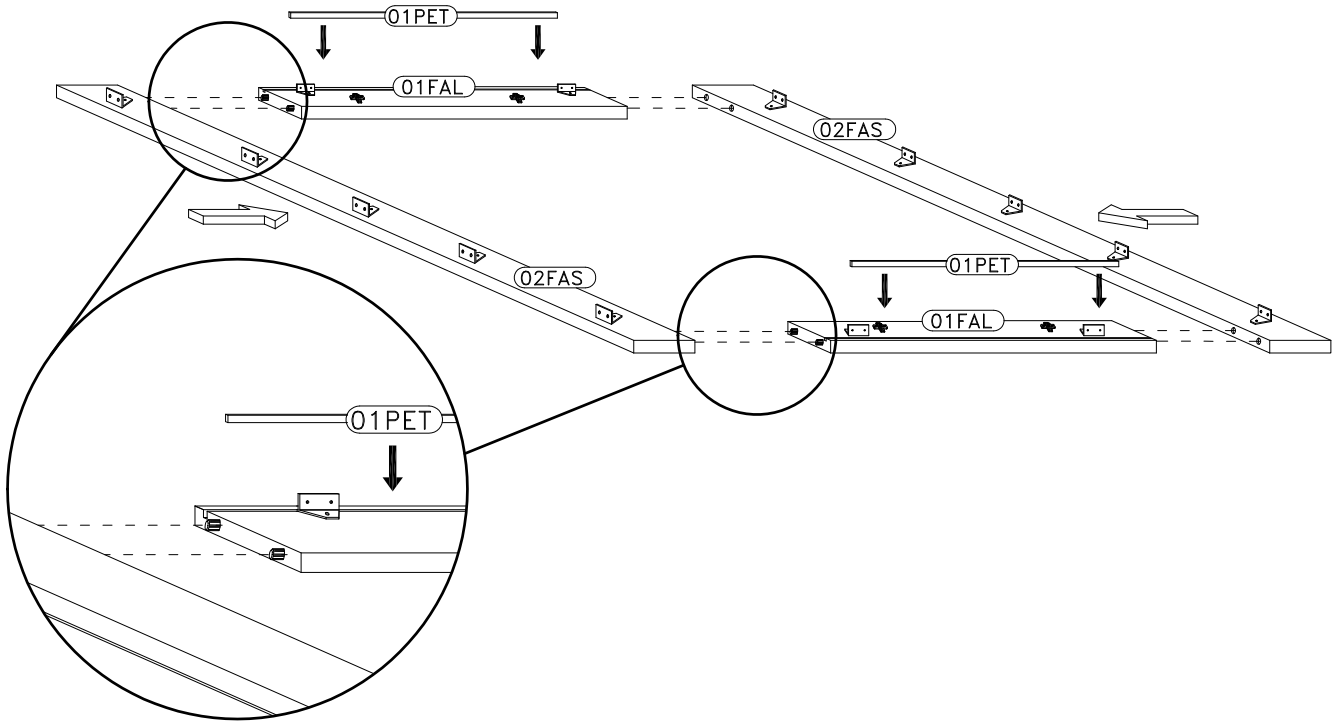
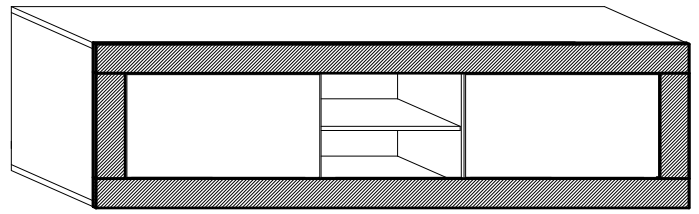

10

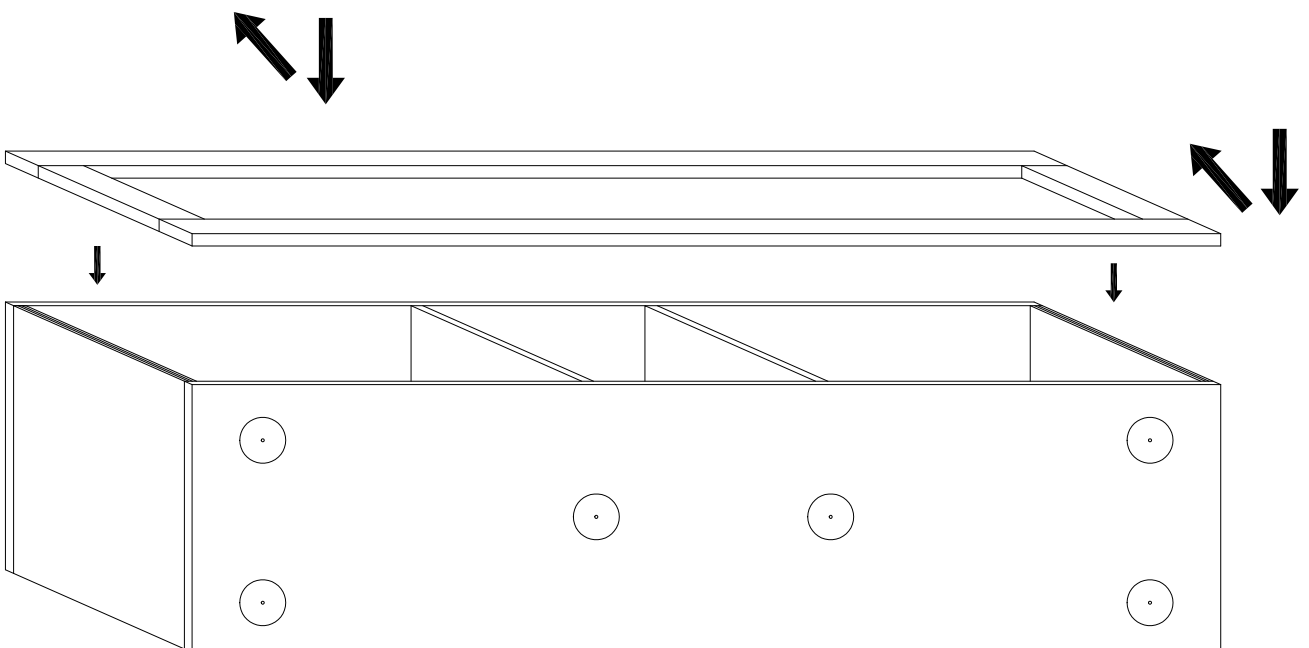

11

L3



4x18 mm.

x28

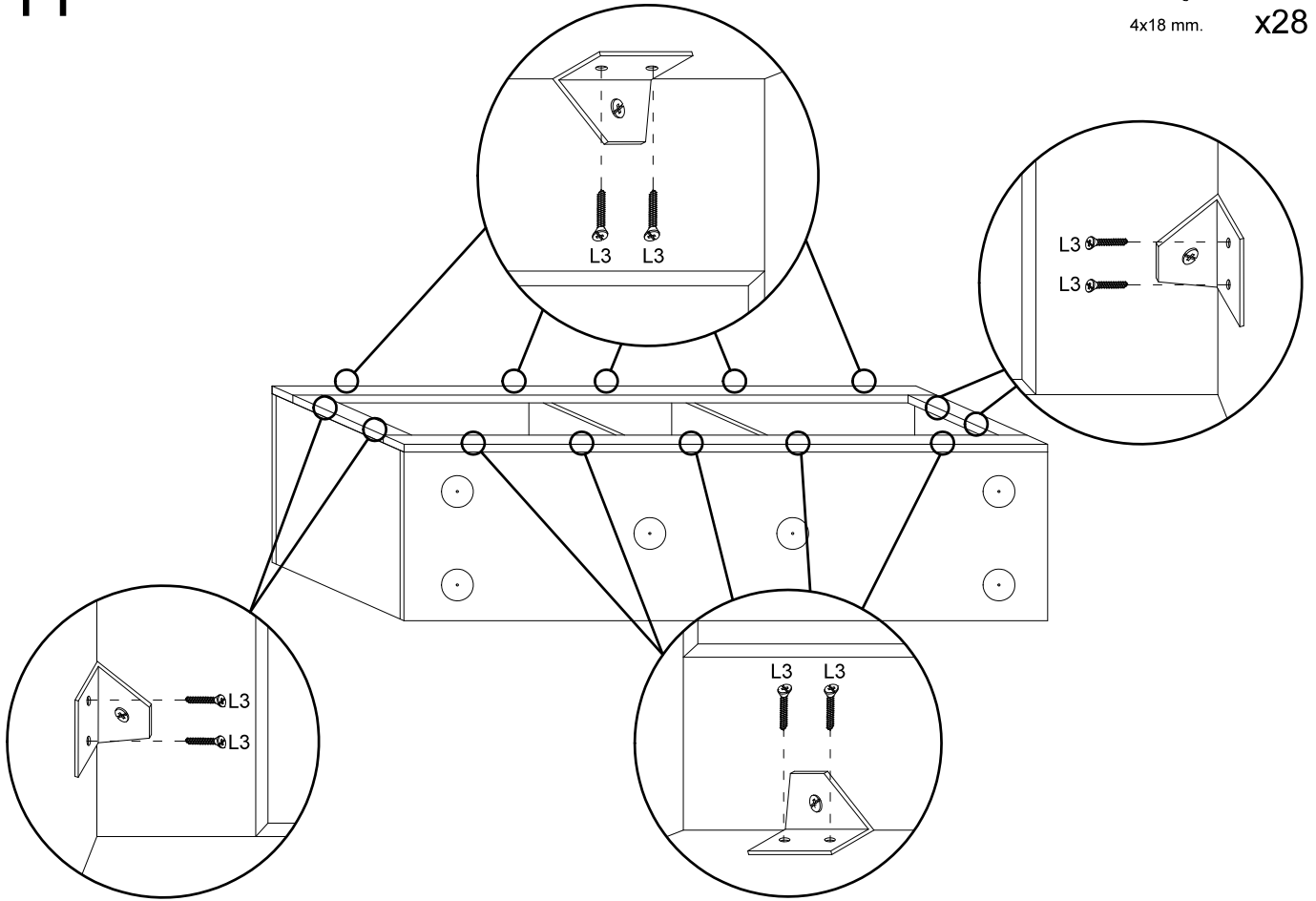

12

L2



4x16 mm.

x8

O1

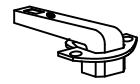

x4

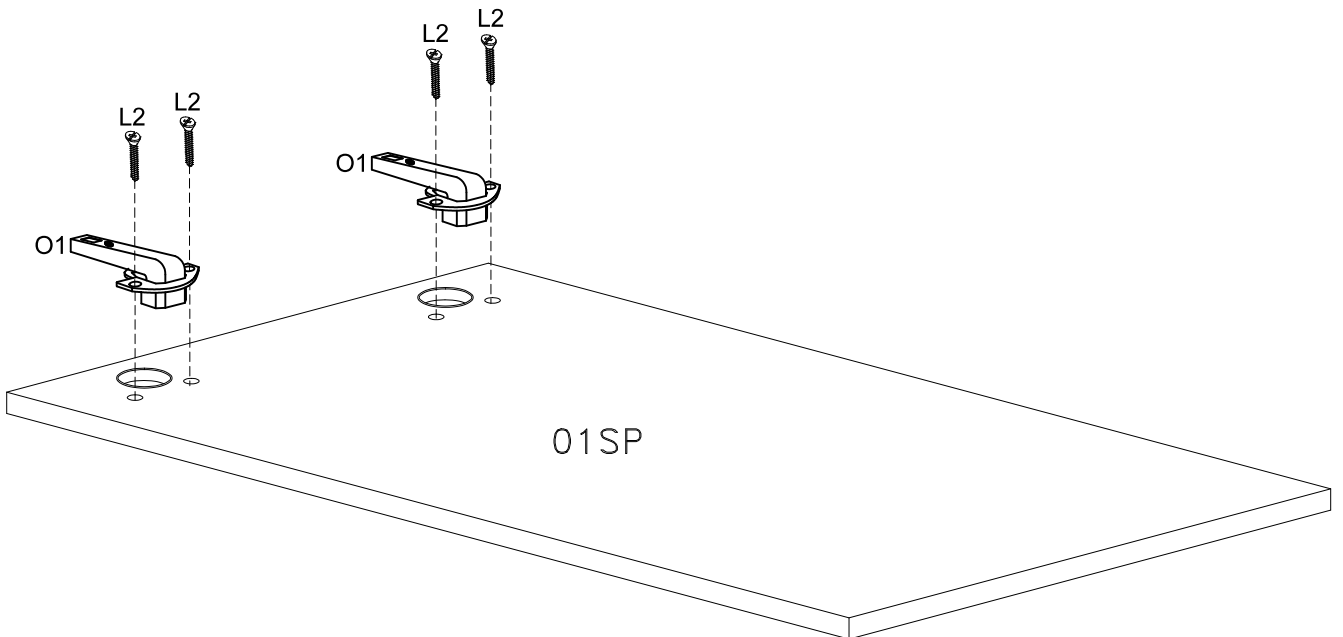

13

P



M2

x4

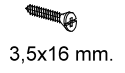

x4

S11



x2

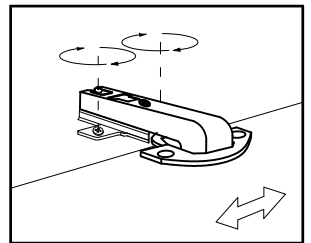
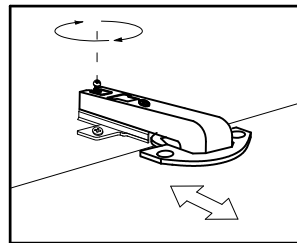
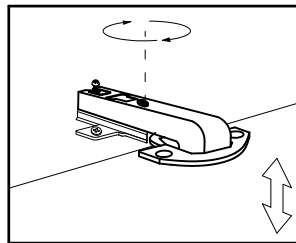
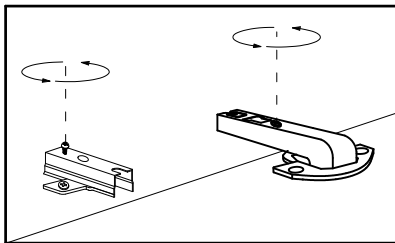
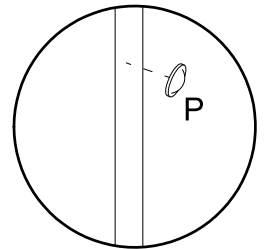
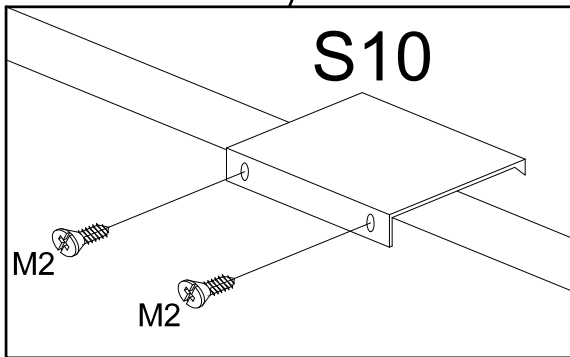
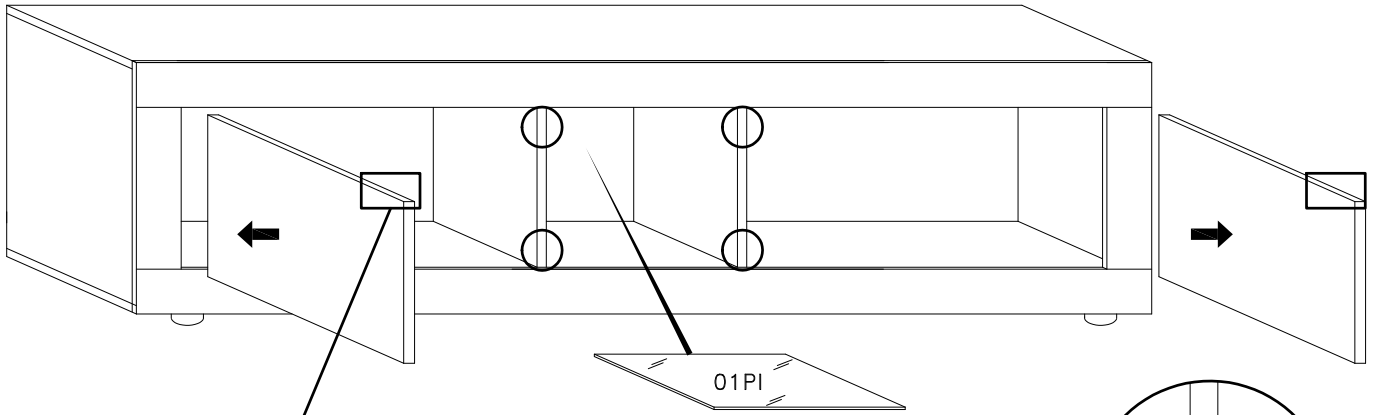

KG 30 MAX

